

10	9	8	7	6	5	4	3	2	1
PART NUMBER	DESCRIPTION								
180412-0001	HOLDER ASSEMBLY - NO CAP								
180412-0002	HOLDER ASSEMBLY - CAP WITH TAB								
180412-0003	HOLDER ASSEMBLY - CAP WITHOUT TAB								

NOTES:

1. MATERIALS: HOUSING: POLYAMIDE (PA66), GLASS FILLED, UL94V-0, 5VA (89992-0289); CAP: POLYAMIDE (PA66) UNFILLED, UL94V-0 (89992-0922); TERMINAL: COPPER ALLOY
2. FINISHES: TERMINAL: NICKEL (Ni) UNDERPLATE 1.27 μm, SELECT TIN (Sn) 2.54μm, SELECT GOLD (Au) 0.76μm
3. PRODUCT SPECIFICATION: PS-180412-001
4. PACKAGING SPECIFICATION: PK-180412-001
5. APPLICATION SPECIFICATION: AS-180412-001
6. FOR USE WITH: CITIZEN COB SERIES CLL010 LED
7. HOLDER ASSEMBLY AVAILABLE WITH OPTIONAL CAP SEE CHART FOR PART NUMBERS
8. WIRE GAUGE: 18 OR 20 AWG, SOLID OR STRANDED WITH TIN OVERCOAT. STRIP LENGTH 1CM.
9. UL:OLFB2 UL496 FILE: E345583.
10. REFERENCE PS-180412-001 FOR RoHAS REQUIREMENTS.

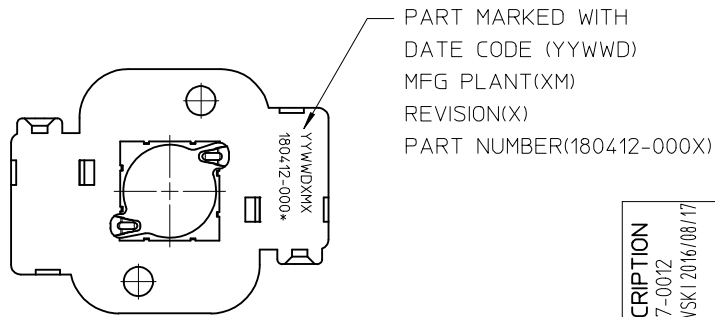
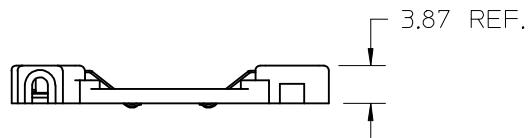
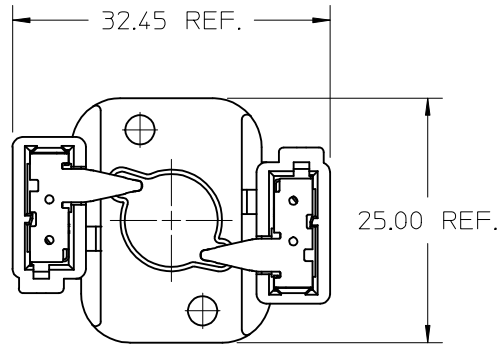

PART MARKED WITH
DATE CODE (YYWWD)
MFG PLANT(XM)
REVISION(X)
PART NUMBER(180412-000X)

HOLDER ASSEMBLY - NO CAP

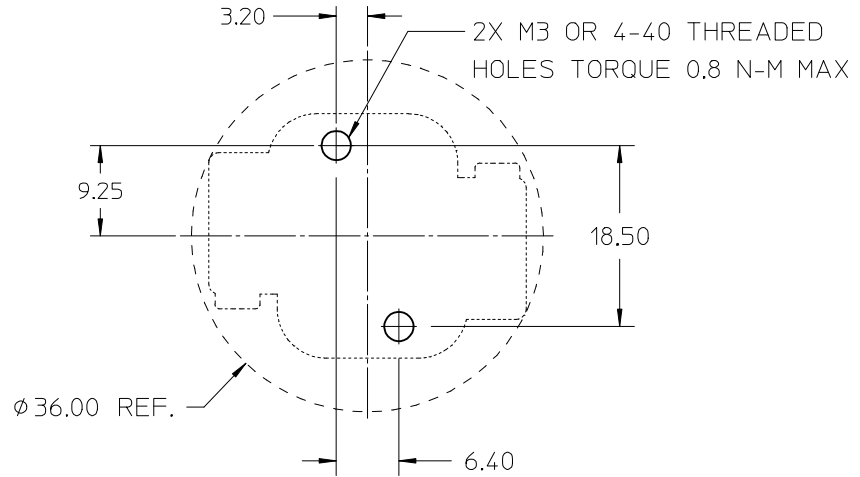

RECOMMENDED MOUNTING DIMENSIONS

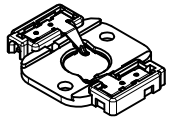

ISO VIEW
Scale 1:1

ENTER DESCRIPTION EC NO: SSL2017-0012 DRAWN: ZABJANOVSKI 2016/08/17 CHKD: APPR: GMEYER 2016/09/21	QUALITY SYMBOLS ▽=0 ▽=0 ▽=0	GENERAL TOLERANCES (UNLESS SPECIFIED)		DIMENSION STYLE		SCALE	DESIGN UNITS	THIRD ANGLE PROJECTION		
				MM ONLY		2:1	METRIC			
				DRAWN BY DATE		TITLE				
				MCOLE 2012/01/30		CITIZEN COB SERIES 9.5MM X 9.5MM HOLDER ASSEMBLY				
		CHECKED BY DATE		MCOLE 2012/05/15		MOLEX		MOLEX INCORPORATED		
		APPROVED BY DATE				DOCUMENT NO.		SD-180412-001		
		ANGULAR ±1/2°		MATERIAL NO.				SHEET NO.		
		DRAFT WHERE APPLICABLE MUST REMAIN WITHIN DIMENSIONS		SEE CHART				1 OF 2		
		SIZE B		THIS DRAWING CONTAINS INFORMATION THAT IS PROPRIETARY TO MOLEX INCORPORATED AND SHOULD NOT BE USED WITHOUT WRITTEN PERMISSION						

10 9 8 7 6 5 4 3 2 1

HOLDER ASSEMBLY - CAP WITH TAB

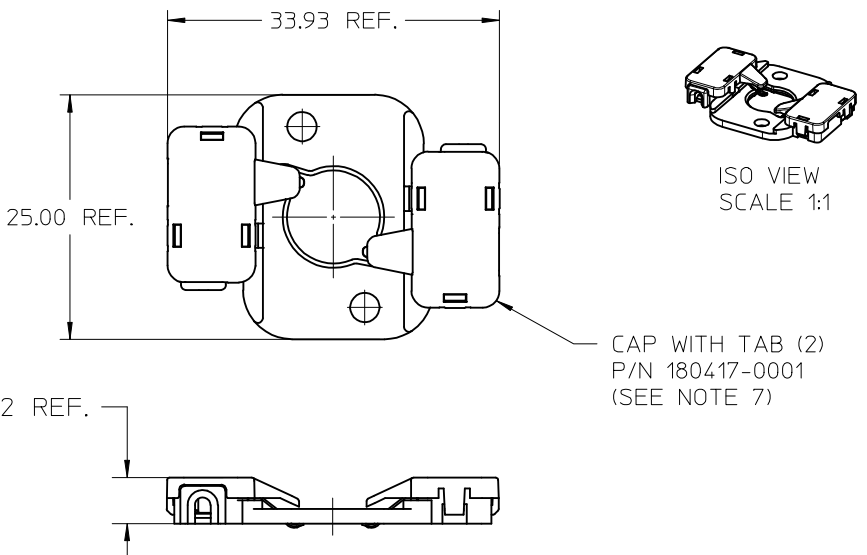

HOLDER ASSEMBLY - CAP WITHOUT TAB

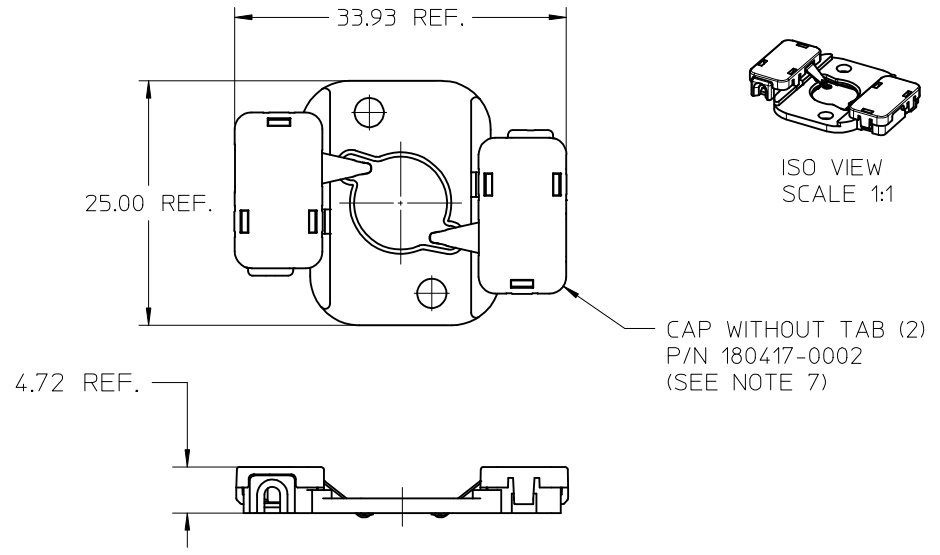

COB MFG	TYPE	DIM 'X'	DIM 'Y'	DIM 'Z'	DIM 'D'
CITIZEN	CLL010, CLL012	9.5	9.5	0.90	7.4

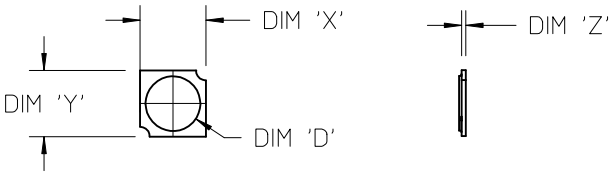

COB LED
SCALE 1:1

ENTER DESCRIPTION EC NO: SSL2017-0012 DRWNL:ZAB.JANOVSKI 2016/08/17 CHKD: APPR:GMEYER 2016/09/21 REV B2	QUALITY SYMBOLS $\nabla=0$ $\nabla=0$ $\nabla=0$	GENERAL TOLERANCES (UNLESS SPECIFIED) <table border="1"> <thead> <tr> <th></th> <th>mm</th> <th>INCH</th> </tr> </thead> <tbody> <tr> <td>4 PLACES</td> <td>± ---</td> <td>± ---</td> </tr> <tr> <td>3 PLACES</td> <td>± ---</td> <td>± ---</td> </tr> <tr> <td>2 PLACES</td> <td>± 0.13</td> <td>± ---</td> </tr> <tr> <td>1 PLACE</td> <td>± 0.25</td> <td>± ---</td> </tr> <tr> <td>0 PLACE</td> <td>± ---</td> <td>± ---</td> </tr> </tbody> </table>		mm	INCH	4 PLACES	± ---	± ---	3 PLACES	± ---	± ---	2 PLACES	± 0.13	± ---	1 PLACE	± 0.25	± ---	0 PLACE	± ---	± ---	DIMENSION STYLE MM ONLY	SCALE 2:1	DESIGN UNITS METRIC	THIRD ANGLE PROJECTION
		mm	INCH																					
	4 PLACES	± ---	± ---																					
	3 PLACES	± ---	± ---																					
	2 PLACES	± 0.13	± ---																					
1 PLACE	± 0.25	± ---																						
0 PLACE	± ---	± ---																						
DRAFT WHERE APPLICABLE MUST REMAIN WITHIN DIMENSIONS		MATERIAL NO. SEE CHART	DRAWN BY MCOLE	DATE 2012/01/30	TITLE CITIZEN COB SERIES 9.5MM X 9.5MM HOLDER ASSEMBLY	SHEET NO. 2 OF 2																		
		ANGULAR $\pm 1/2^\circ$	CHECKED BY MCOLE	DATE 2012/05/15	DOCUMENT NO. SD-180412-001																			
			APPROVED BY	DATE	THIS DRAWING CONTAINS INFORMATION THAT IS PROPRIETARY TO MOLEX INCORPORATED AND SHOULD NOT BE USED WITHOUT WRITTEN PERMISSION																			
			SIZE B																					

9 8 7 6 5 4 3 2 1

10	9	8	7
PART NUMBER	DESCRIPTION		
180412-0001	HOLDER ASSEMBLY - NO CAP		
180412-0002	HOLDER ASSEMBLY - CAP WITH TAB		
180412-0003	HOLDER ASSEMBLY - CAP WITHOUT TAB		

- NOTES:
1. MATERIALS: HOUSING: POLYAMIDE (PA66), GLASS FILLED, UL94V-0, 5VA (89992-0289); CAP: POLYAMIDE (PA66) UNFILLED, UL94V-0 (89992-0922); TERMINAL: COPPER ALLOY
 2. FINISHES: TERMINAL: NICKEL (Ni) UNDERPLATE 1.27 μ m, SELECT TIN (Sn) 2.54 μ m, SELECT GOLD (Au) 0.76 μ m
 3. PRODUCT SPECIFICATION: PS-180412-001
 4. PACKAGING SPECIFICATION: PK-180412-001
 5. APPLICATION SPECIFICATION: AS-180412-001
 6. FOR USE WITH: CITIZEN COB SERIES CLL010 LED
 7. HOLDER ASSEMBLY AVAILABLE WITH OPTIONAL CAP SEE CHART FOR PART NUMBERS
 8. WIRE GAUGE: 18 OR 20 AWG, SOLID OR STRANDED WITH TIN OVERCOAT. STRIP LENGTH 1CM.
 9. UL:OLFB2 UL496 FILE: E345583.
 10. REFERENCE PS-180412-001 FOR RoHAS REQUIREMENTS.

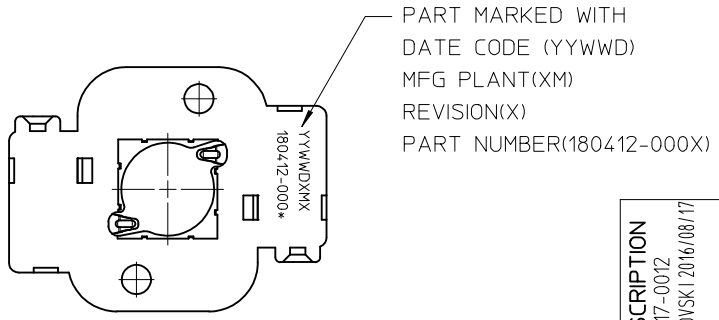
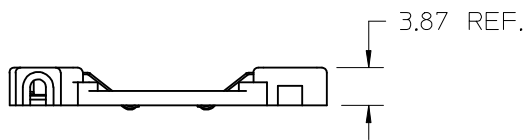
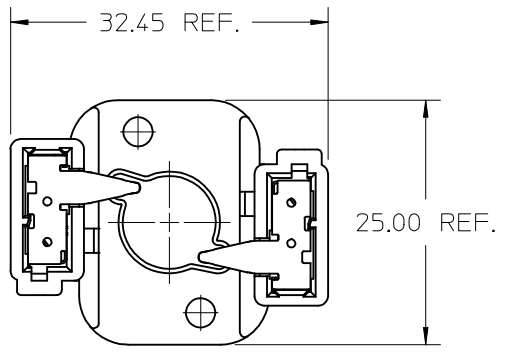

PART MARKED WITH DATE CODE (YYWWD) MFG PLANT(XM) REVISION(X) PART NUMBER(180412-000X)

HOLDER ASSEMBLY - NO CAP

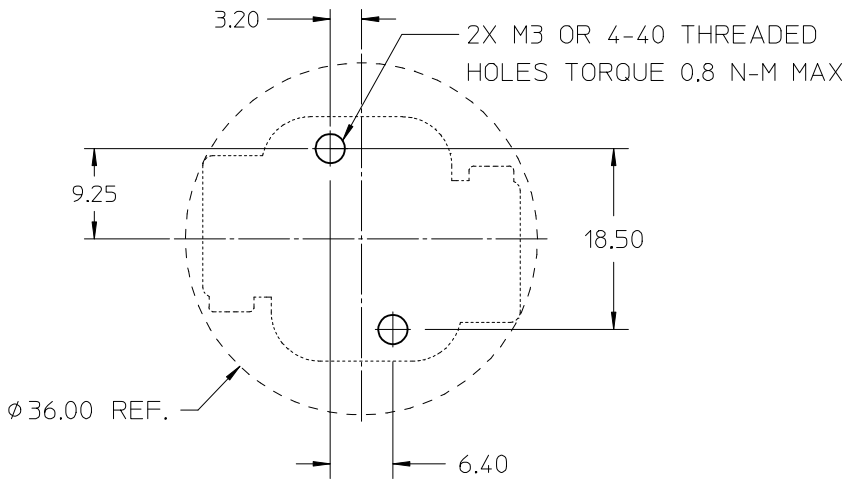

RECOMMENDED MOUNTING DIMENSIONS

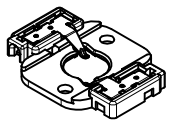

ISO VIEW Scale 1:1

ENTER DESCRIPTION EC NO: SSL2017-0012 DRAWN: ZABJANOVSKI 2016/08/17 CHKD: APPR: GMEYER 2016/09/21 B2	QUALITY SYMBOLS $\nabla=0$ $\nabla=0$ $\nabla=0$	GENERAL TOLERANCES (UNLESS SPECIFIED)		DIMENSION STYLE MM ONLY		SCALE 2:1	DESIGN UNITS METRIC	THIRD ANGLE PROJECTION
		4 PLACES \pm --- \pm --- 3 PLACES \pm --- \pm --- 2 PLACES \pm 0.13 \pm --- 1 PLACE \pm 0.25 \pm ---	mm INCH	DRAWN BY: MCOLE DATE: 2012/01/30	CHECKED BY: MCOLE DATE: 2012/05/15	TITLE CITIZEN COB SERIES 9.5MM X 9.5MM HOLDER ASSEMBLY		
		ANGULAR \pm 1/2°		APPROVED BY: MCOLE DATE:		MOLEX INCORPORATED		
		DRAFT WHERE APPLICABLE MUST REMAIN WITHIN DIMENSIONS		MATERIAL NO. SEE CHART		DOCUMENT NO. SD-180412-001	SHEET NO. 1 OF 2	

10 9 8 7 6 5 4 3 2 1

HOLDER ASSEMBLY - CAP WITH TAB

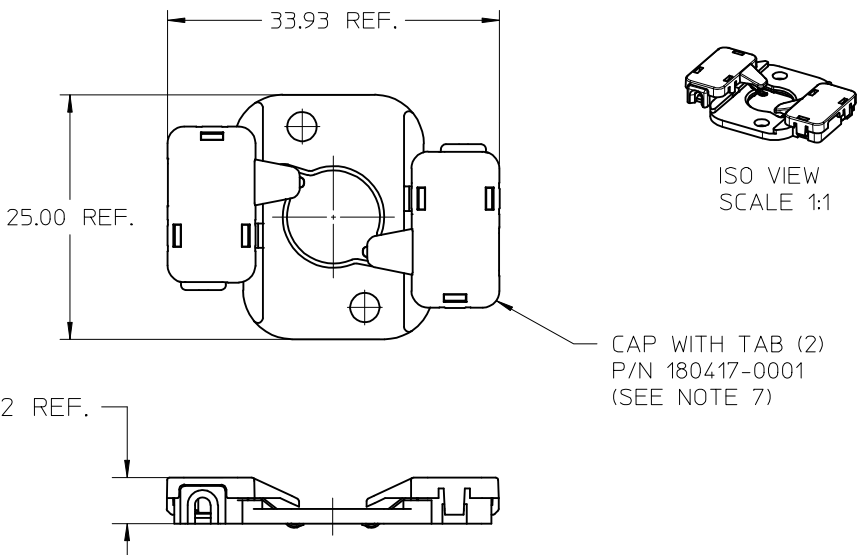

HOLDER ASSEMBLY - CAP WITHOUT TAB

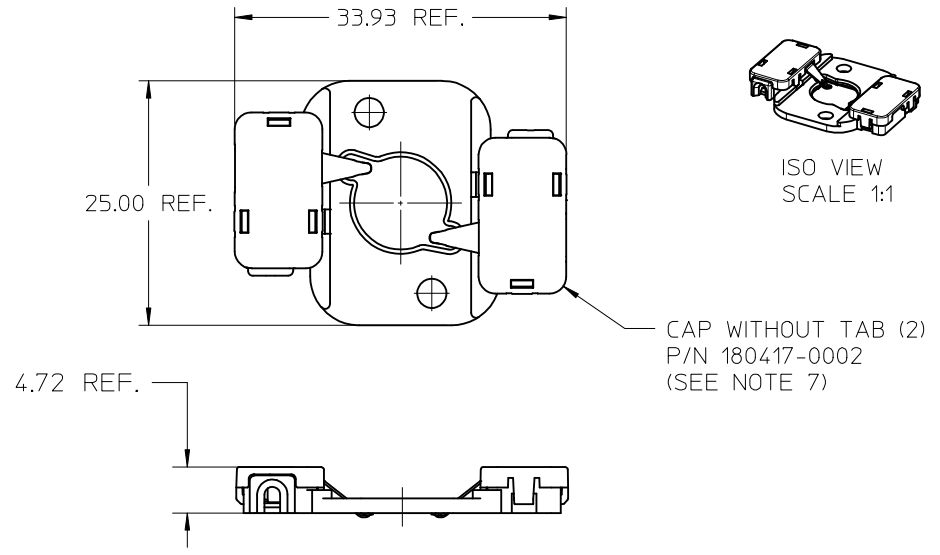

COB MFG	TYPE	DIM 'X'	DIM 'Y'	DIM 'Z'	DIM 'D'
CITIZEN	CLL010, CLL012	9.5	9.5	0.90	7.4

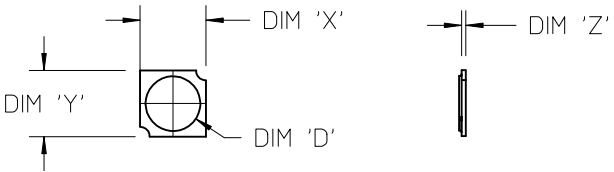

COB LED
SCALE 1:1

ENTER DESCRIPTION EC NO: SSL2017-0012 /DRWNLZABJANOVSKI 2016/08/17 CHKD: APPR:GMEYER 2016/09/21 REV B2	QUALITY SYMBOLS $\nabla=0$ $\nabla=0$ $\nabla=0$	GENERAL TOLERANCES (UNLESS SPECIFIED) <table border="1"> <thead> <tr> <th></th> <th>mm</th> <th>INCH</th> </tr> </thead> <tbody> <tr> <td>4 PLACES</td> <td>± ---</td> <td>± ---</td> </tr> <tr> <td>3 PLACES</td> <td>± ---</td> <td>± ---</td> </tr> <tr> <td>2 PLACES</td> <td>± 0.13</td> <td>± ---</td> </tr> <tr> <td>1 PLACE</td> <td>± 0.25</td> <td>± ---</td> </tr> <tr> <td>0 PLACE</td> <td>± ---</td> <td>± ---</td> </tr> </tbody> </table>		mm	INCH	4 PLACES	± ---	± ---	3 PLACES	± ---	± ---	2 PLACES	± 0.13	± ---	1 PLACE	± 0.25	± ---	0 PLACE	± ---	± ---	DIMENSION STYLE MM ONLY	SCALE 2:1	DESIGN UNITS METRIC	THIRD ANGLE PROJECTION
		mm	INCH																					
	4 PLACES	± ---	± ---																					
	3 PLACES	± ---	± ---																					
	2 PLACES	± 0.13	± ---																					
1 PLACE	± 0.25	± ---																						
0 PLACE	± ---	± ---																						
DRAFT WHERE APPLICABLE MUST REMAIN WITHIN DIMENSIONS		MATERIAL NO. SEE CHART	DRAWN BY MCOLE	DATE 2012/01/30	TITLE CITIZEN COB SERIES 9.5MM X 9.5MM HOLDER ASSEMBLY	SHEET NO. 2 OF 2																		
		ANGULAR $\pm 1/2^\circ$	CHECKED BY MCOLE	DATE 2012/05/15	DOCUMENT NO. SD-180412-001																			
			APPROVED BY	DATE	THIS DRAWING CONTAINS INFORMATION THAT IS PROPRIETARY TO MOLEX INCORPORATED AND SHOULD NOT BE USED WITHOUT WRITTEN PERMISSION																			
			SIZE B																					

9 8 7 6 5 4 3 2 1