

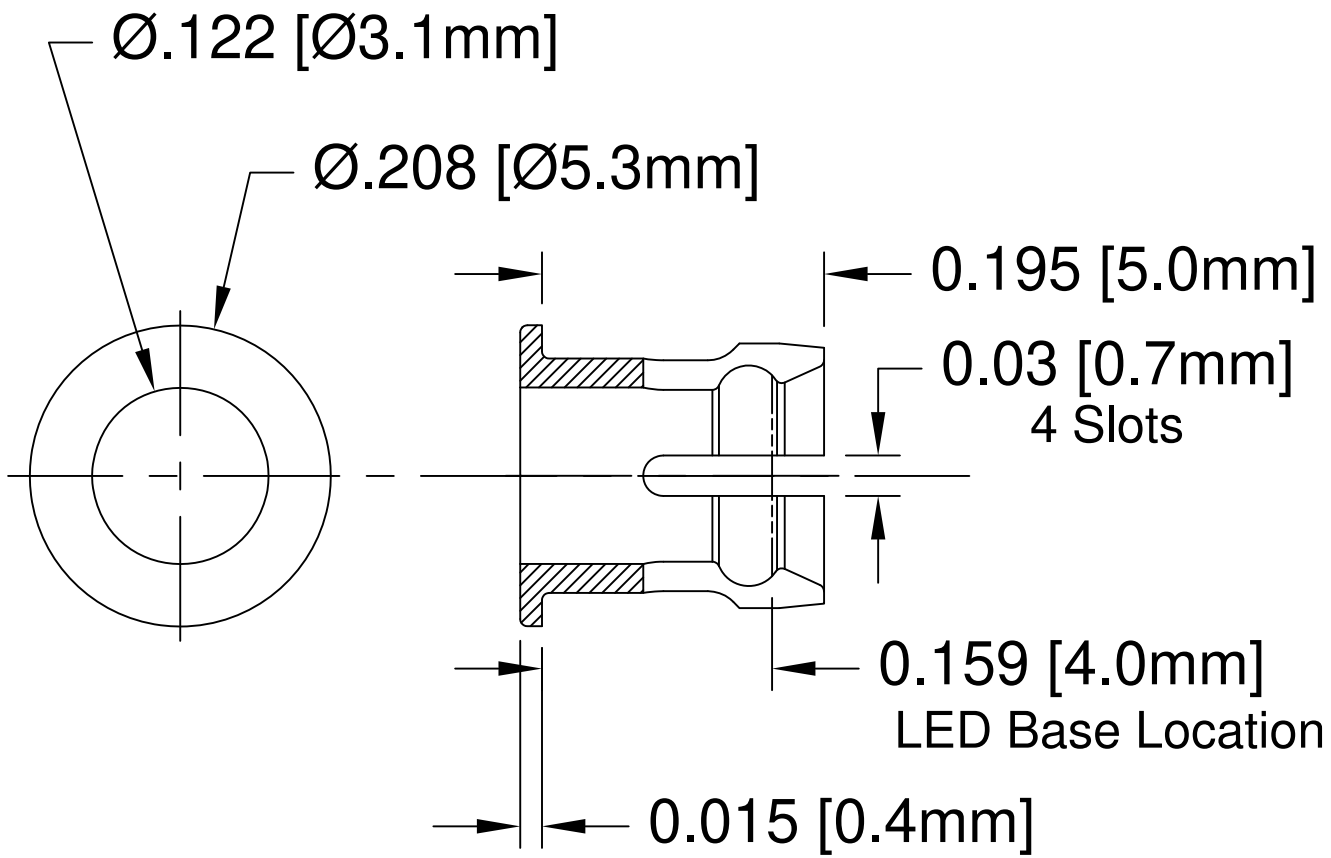

REV.	DESCRIPTION	DATE	APPROVED
A	Engineering Release	11/11/02	M. C.
B	Engineering Update w/o Changes	06/14/04	M. C.
C	Removed Material Code	05/28/16	J. C.



2. MATERIAL: NYLON 6/6, 94V-0, BLACK.

1. GENERAL SPECIFICATIONS: BIVAR MOLDED COMPONENT SPECIFICATION BV00-E101.

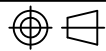
STANDARD TOLERANCE (UNLESS OTHERWISE SPECIFIED)		 4 THOMAS, IRVINE, CA. 92618 TEL: (949) 951-8808 FAX: (949) 951-3974	
DECIMALS	ANGULAR		
.X ± .1	X° ± 1°	 TITLE: T-1 (3mm) LED CLIP	
.XX ± .01			
.XXX ± .005			
DESIGNED: D. Green	DATE: 11/11/02	PART NO: C-104	REVISION: C
CHECKED: M. Chen	DATE: 11/11/02	CAGE CODE : 32559	SHEET # 1 OF 1
CAD GENERATED DOCUMENT. DO NOT MEASURE DRAWING.			