

Three Phase Rectifier Bridge with IGBT and Fast Recovery Diode for Braking System in ECO-PAC 2

$$V_{RRM} = 1200/1600 \text{ V}$$

$$I_{dAVM} = 56 \text{ A}$$

V_{RRM} V	Type
1200	VUB 50-12 PO1
1600	VUB 50-16 PO1

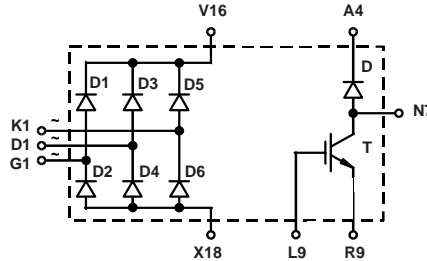

Input Rectifier D1 - D6

Symbol	Conditions	Maximum Ratings	
V_{RRM}		1200/1600	V
I_{FAV}	$T_C = 100^\circ\text{C}$; sine 180°	22	A
I_{dAVM}	$T_C = 100^\circ\text{C}$; rectangular; $d = 1/3$; bridge	56	A
I_{FSM}	$T_{VJ} = 25^\circ\text{C}$; $t = 10 \text{ ms}$; sine 50 Hz	300	A
P_{tot}	$T_C = 25^\circ\text{C}$	90	W

Features

- three phase mains rectifier
- brake chopper:
 - IGBT with low saturation voltage
 - HiPerFRED™ free wheeling diode
- module package:
 - high level of integration
 - solder terminals for PCB mounting
 - isolated DCB ceramic base plate

Symbol	Conditions	Characteristic Values ($T_{VJ} = 25^\circ\text{C}$, unless otherwise specified)		
		min.	typ.	max.
V_F	$I_F = 45 \text{ A}$; $T_{VJ} = 25^\circ\text{C}$ $T_{VJ} = 125^\circ\text{C}$		1.3 1.2	1.6 V V
I_R	$V_R = V_{RRM}$; $T_{VJ} = 25^\circ\text{C}$ $V_R = 0.8 \cdot V_{RRM}$; $T_{VJ} = 125^\circ\text{C}$		0.4	0.2 mA mA
R_{thJC} R_{thJH}	per diode; rectangular 120° with heat transfer paste		1.8	1.45 K/W K/W

Applications

- drives with
- mains input
 - DC link
 - inverter or chopper feeding the machine
 - motor and generator/brake operation

Chopper Diode D

Symbol	Conditions	Maximum Ratings	
V_{RRM}	$T_{VJ} = 25^\circ\text{C}$ to 150°C	1200	V
I_{F25}	DC; $T_C = 25^\circ\text{C}$	15	A
I_{F80}	DC; $T_C = 80^\circ\text{C}$	10	A

Symbol	Conditions	Characteristic Values		
		min.	typ.	max.
V_F	$I_F = 10 \text{ A}$; $T_{VJ} = 25^\circ\text{C}$ $T_{VJ} = 125^\circ\text{C}$		2.6 1.9	3.0 V V
I_R	$V_R = V_{RRM}$; $T_{VJ} = 25^\circ\text{C}$ $T_{VJ} = 125^\circ\text{C}$		0.06	0.06 mA mA
I_{RM} t_{rr}	$I_F = 10 \text{ A}$; $di_F/dt = -400 \text{ A}/\mu\text{s}$; $T_{VJ} = 125^\circ\text{C}$ $V_R = 600 \text{ V}$		13 110	A ns
R_{thJC} R_{thJH}	with heat transfer paste		5	3.5 K/W K/W

IXYS reserves the right to change limits, test conditions and dimensions.

Chopper Transistor T

Symbol	Conditions	Maximum Ratings	
V_{CES}	$T_{VJ} = 25^{\circ}\text{C}$ to 150°C	1200	V
V_{GES}		± 20	V
I_{C25}	DC; $T_C = 25^{\circ}\text{C}$	18	A
I_{C80}	DC; $T_C = 80^{\circ}\text{C}$	14	A
I_{CM}	$V_{GE} = \pm 15\text{ V}$; $R_G = 82\ \Omega$; $T_{VJ} = 125^{\circ}\text{C}$	20	A
V_{CEK}	RBSOA; $L = 100\ \mu\text{H}$; clamped inductive load	V_{CES}	

Symbol	Conditions	Characteristic Values ($T_{VJ} = 25^{\circ}\text{C}$, unless otherwise specified)		
		min.	typ.	max.
$V_{CE(sat)}$	$I_C = 10\text{ A}$; $V_{GE} = 15\text{ V}$; $T_{VJ} = 25^{\circ}\text{C}$ $T_{VJ} = 125^{\circ}\text{C}$		2.3 2.7	V V
$V_{GE(th)}$	$I_C = 0.4\text{ mA}$; $V_{GE} = V_{CE}$	4.5		6.5 V
I_{CES}	$V_{CE} = V_{CES}$; $V_{GE} = 0\text{ V}$; $T_{VJ} = 25^{\circ}\text{C}$ $T_{VJ} = 125^{\circ}\text{C}$		0.8	0.5 mA mA
I_{GES}	$V_{CE} = 0\text{ V}$; $V_{GE} = \pm 20\text{ V}$			200 nA
$t_{d(on)}$	Inductive load, $T_{VJ} = 125^{\circ}\text{C}$ $V_{CE} = 600\text{ V}$; $I_C = 10\text{ A}$ $V_{GE} = \pm 15\text{ V}$; $R_G = 82\ \Omega$		50	ns
t_r			40	ns
$t_{d(off)}$			290	ns
t_f			60	ns
E_{on}			1.2	mJ
E_{off}		1.1	mJ	
C_{ies}	$V_{CE} = 25\text{ V}$; $V_{GE} = 0\text{ V}$; $f = 1\text{ MHz}$		600	pF
Q_{Gon}	$V_{CE} = 600\text{ V}$; $V_{GE} = 15\text{ V}$; $I_C = 10\text{ A}$		45	nC
R_{thJC}	with heat transfer paste			1.4 K/W
R_{thJH}			2.7	K/W

Dimensions in mm (1 mm = 0.0394")

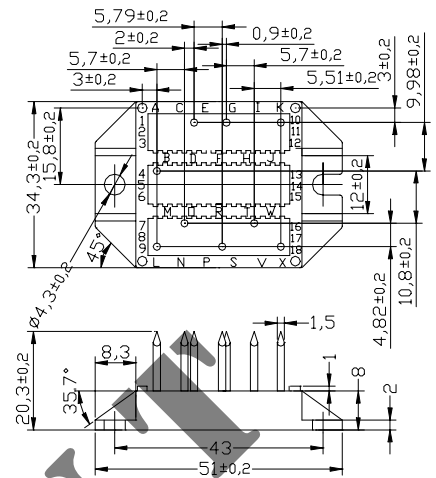
Module

Symbol	Conditions	Maximum Ratings	
T_{VJ}		-40...+150	$^{\circ}\text{C}$
T_{stg}		-40...+125	$^{\circ}\text{C}$
V_{ISOL}	$I_{ISOL} \leq 1\text{ mA}$; 50/60 Hz; $t = 1\text{ sec}$	3600	V~
M_d	Mounting torque (M5)	1.5 - 2 14 - 18	Nm lb.in.

Symbol	Conditions	Characteristic Values		
		min.	typ.	max.
d_A, d_S	pin to heatsink	11.2		mm
Weight			24	g