

SECTION B-B
SHOWN WITH CPA (WHEN APPLICABLE)
IN IT'S LATCHED POSITION
FOR REFERENCE ONLY

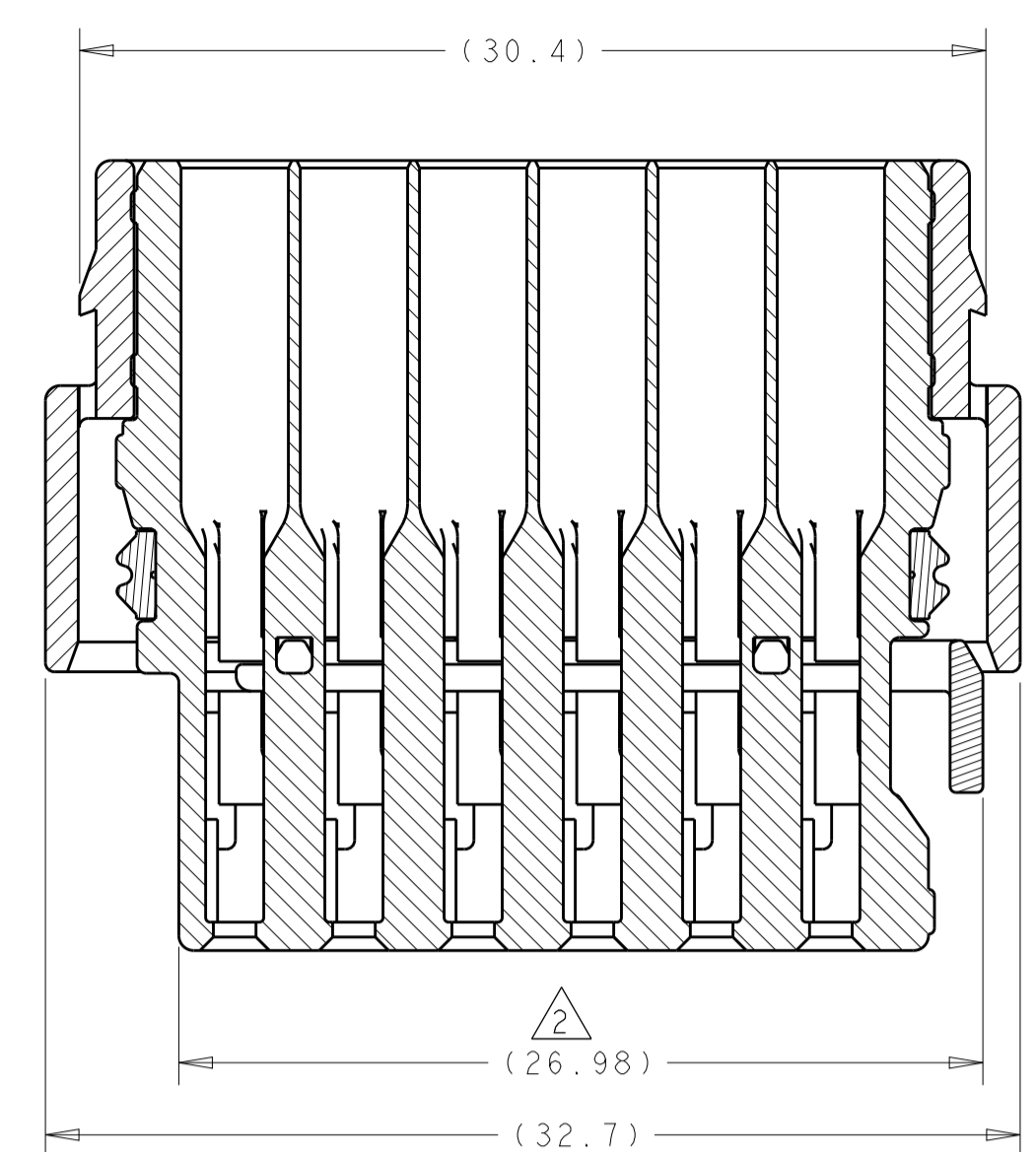

SECTION A-A
SHOWN WITH TPA
IN IT'S LATCHED POSITION
FOR REFERENCE ONLY

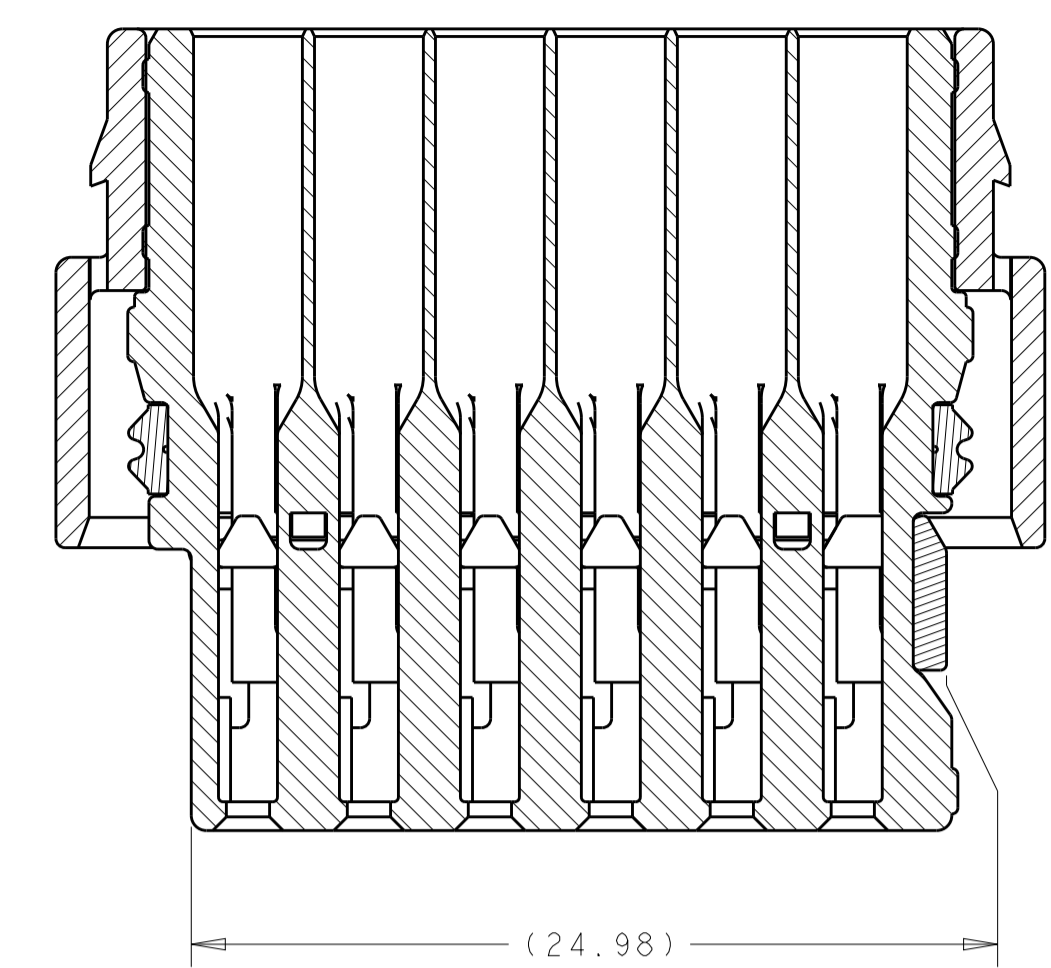

SECTION A-A
SHOWN WITH TPA
IN IT'S LATCHED POSITION
FOR REFERENCE ONLY

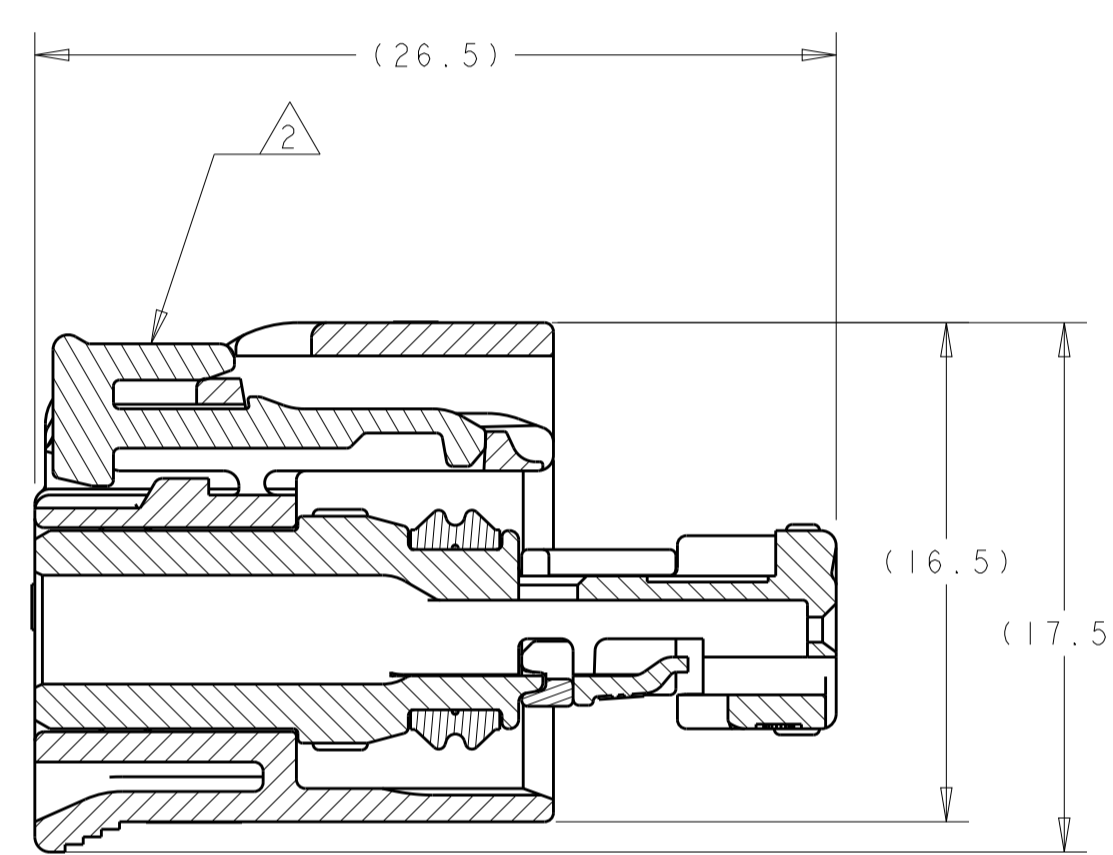
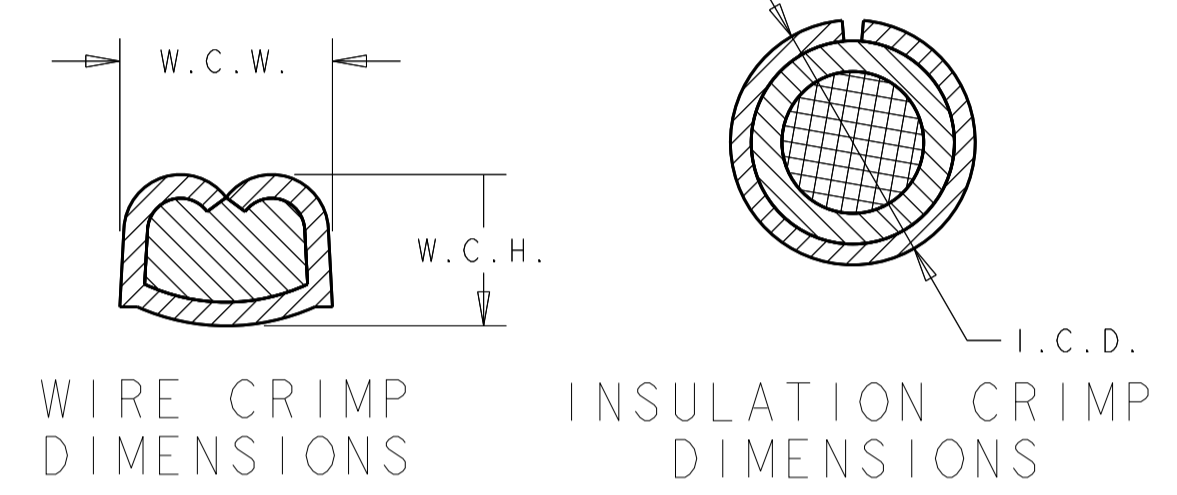
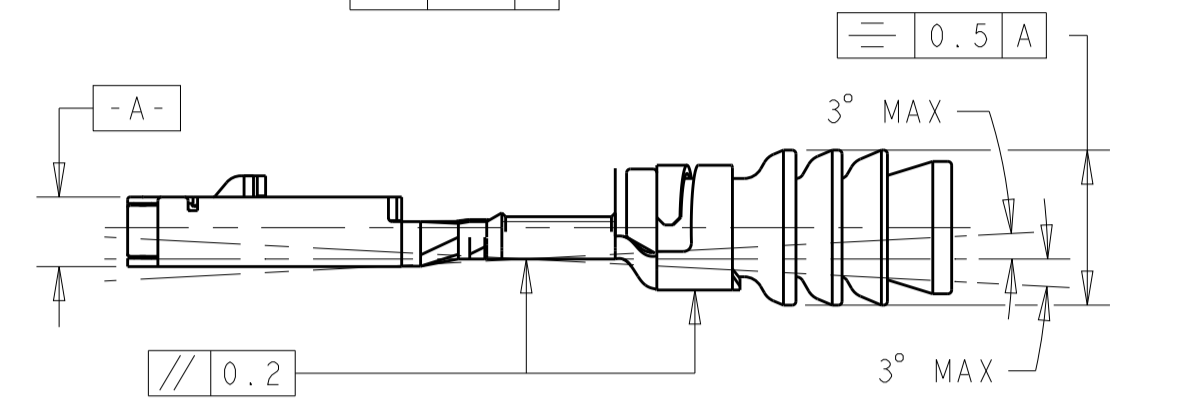
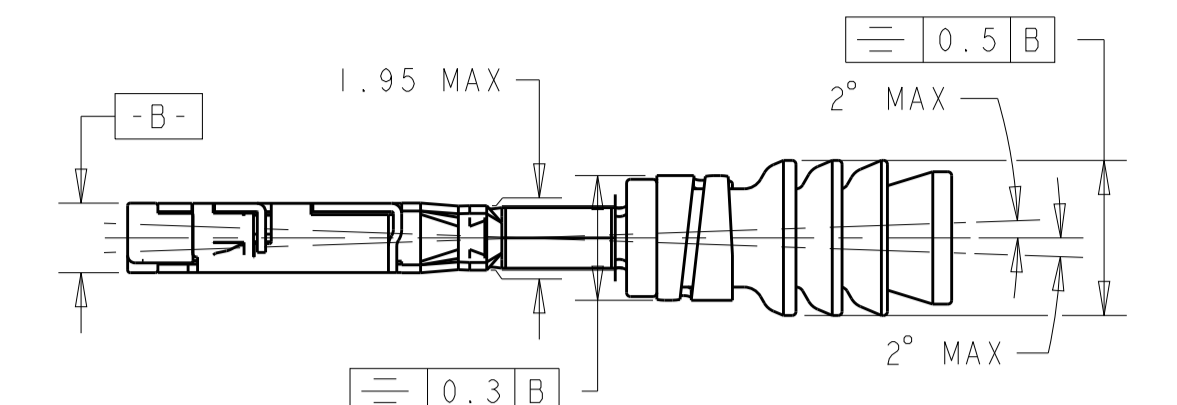

SECTION B-B

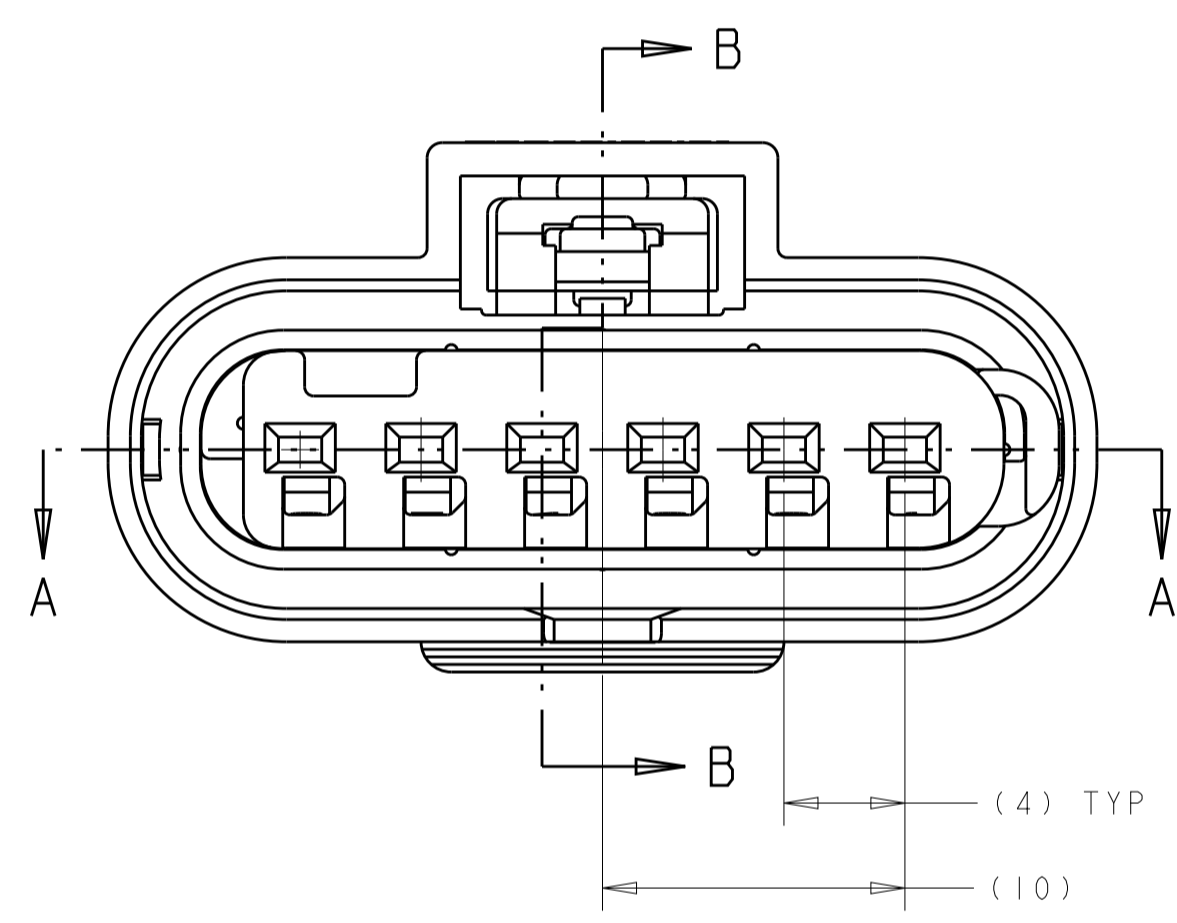

TE MCON 1.2-CB (CLEAN BODY)								
1670146-3	SILVER	3.6 ±0.3	20	1.4 TO 1.9	0.84 ±0.03	1.57 ±0.05	3.25±0.05	967067-1
1670146-2	GOLD							
1670146-1	TIN							
1418850-3	SILVER	3.6 ±0.3	18	1.9 TO 2.4	1.11 ±0.05	1.78 ±0.05	3.35±0.05	964972-1
1418850-2	GOLD							
1418850-1	TIN							
PART NUMBER	PLATING	WIRE STRIP LENGTH	AWG	INSL. RANGE	W.C.H.	W.C.W.	I.C.D.	WIRE SEAL PART NUMBER

KEYING CONFIGURATIONS

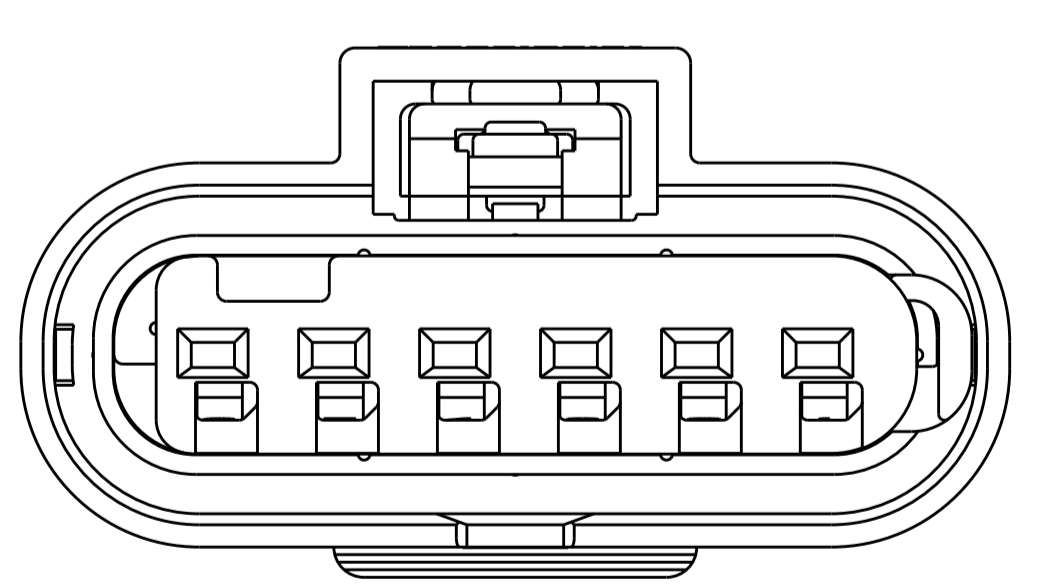

KEYING OPTION A

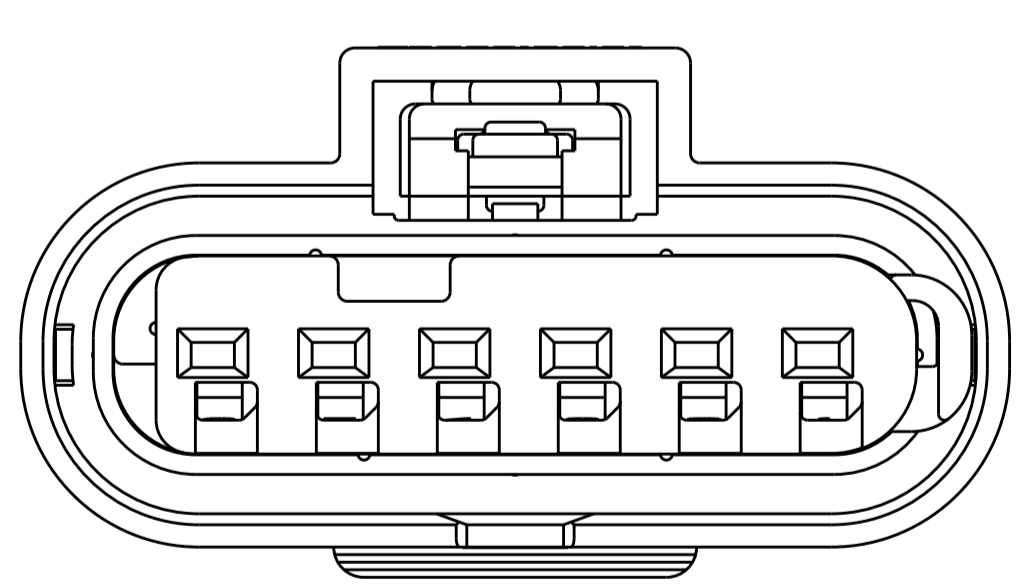

KEYING OPTION B

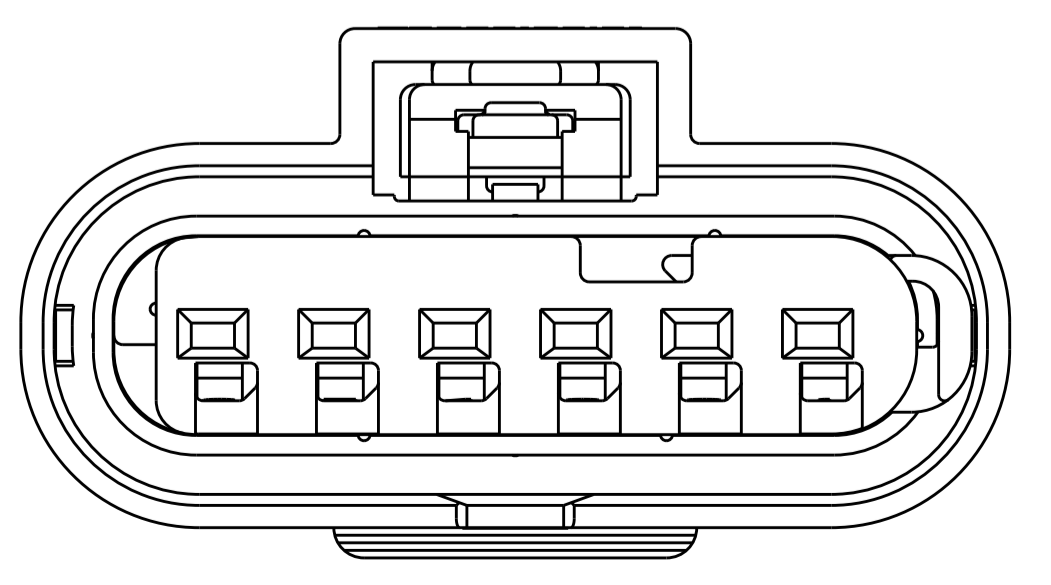

KEYING OPTION C

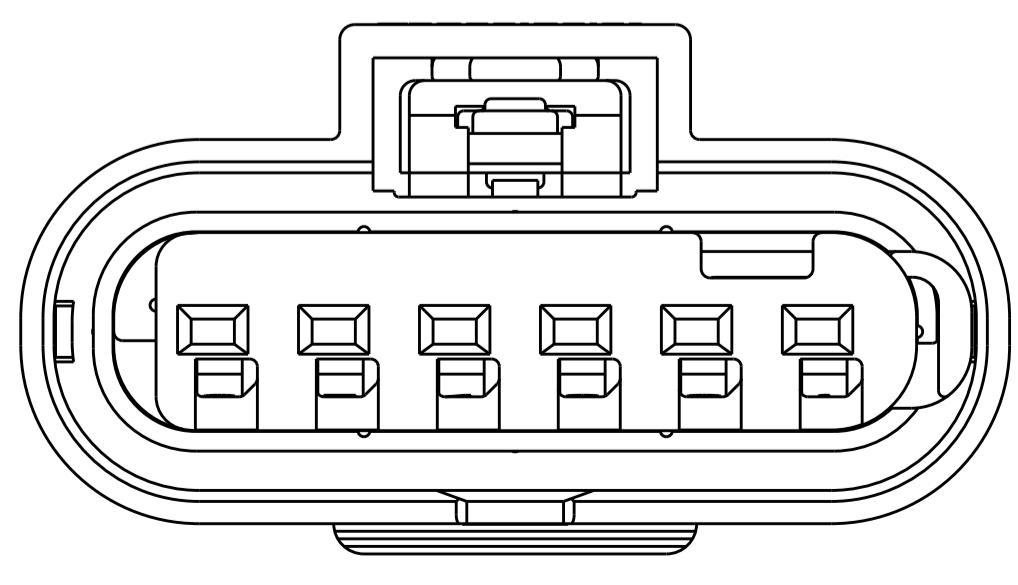

KEYING OPTION D

- PART NUMBER 1924292-5 SHOWN ON DRAWING.
- TPA AND CPA (WHEN APPLICABLE) ARE SHIPPED IN THEIR PRE-LATCHED POSITIONS. SEE INSTRUCTION SHEET 408-8968 FOR DIRECTIONS ON MOVING THE CPA AND TPA TO THE PRE-LATCHED POSITION, IF NECESSARY.
- TERMINALS SOLD SEPARATELY. FOR USE WITH TE MCON 1.2mm CLEAN BODY CONTACT WITH WIRE SEAL. SEE TE MCON 1.2-CB (CLEAN BODY) TABLE FOR APPLICABLE PART NUMBERS.
- APPLICABLE HEADER INTERFACE DRAWING 114-18679-3 IS AVAILABLE UPON REQUEST. A COPY OF THIS DRAWING CAN BE OBTAINED FROM THE TYCO ELECTRONICS PRODUCT MANAGER, VIA YOUR TYCO ELECTRONICS SALES REPRESENTATIVE OR CUSTOMER SERVICE.
- MINIMUM FEED THROUGH CONDITION WITH 1.0mm CLEARANCE ALL AROUND.
- TRACEABILITY CODE (YY = TWO DIGIT YEAR, JJJ = 3 DIGIT JULIAN DAY, S = 1 DIGIT SHIFT) AND TYCO ELECTRONICS ASSEMBLY PART NUMBER PRINTED IN THIS LOCATION AT ASSEMBLY.
- FOR OPTIONAL TERMINAL CAVITY BLOCKING, USE TE BLIND PLUG PART NUMBER: 967056-1.
- VALIDATED UP TO USCAR TEMPERATURE CLASS III.
- TPA ENGAGE FORCE: PRESET TO FULL >= 3 N AND <= 60 N.
- TPA DISENGAGE FORCE: DISENGAGE FROM FULL TO PRESET >= 6 N AND <= 60 N.
- CPA ENGAGE FORCE: PRESET TO FULL WITHOUT CONNECTORS MATED >= 40 N.
- CPA ENGAGE FORCE: PRESET TO FULL WITH CONNECTORS MATED < 30 N.
- POLARIZATION FEATURE EFFECTIVENESS: CONNECTOR MATED TURNED 180° NO MATING > 150 N. WRONG KEYING NO MATING > 150 N.
- SEE INSTRUCTION SHEET 408-8928
- TERMINAL 1670146-X REPLACES 1418847-X
- REFERENCE ISOMETRIC VIEWS ON SHEET 2.

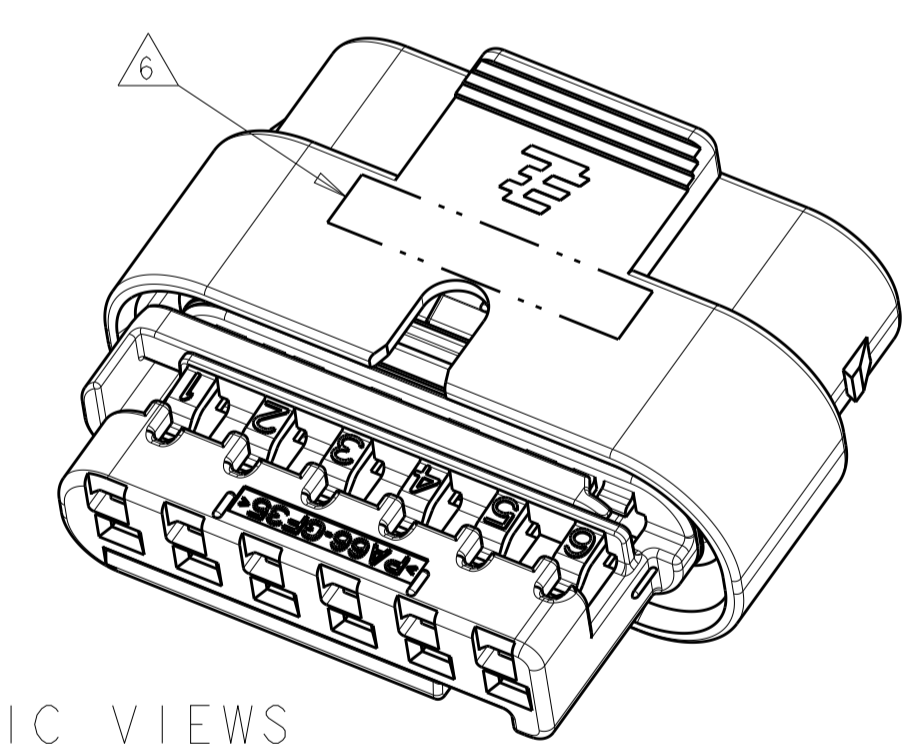
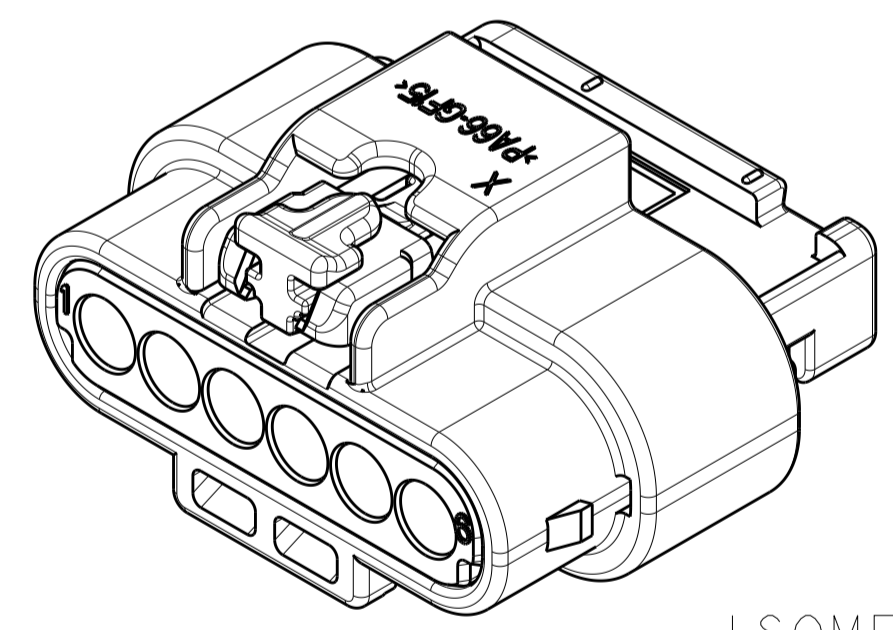

ISOMETRIC VIEWS
SCALE 3:1

RELEASED	2138907-1	GRAY	D	4-1924292-4
RELEASED	2138907-1	BLUE	C	4-1924292-3
RELEASED	2138907-1	NATURAL	B	4-1924292-2
RELEASED	1488787-1	GRAY	D	1924292-8
		BLUE	C	1924292-7
		NATURAL	B	1924292-6
		BLACK	A	1924292-5
RELEASED	N/A	GRAY	D	1924292-4
		BLUE	C	1924292-3
		NATURAL	B	1924292-2
		BLACK	A	1924292-1
STATUS	CPA	COLOR	KEY	PART NUMBER
		INNER HOUSING		

THIS DRAWING IS A CONTROLLED DOCUMENT.

DMN: M. HITCHCOCK 6 JAN 2007
CHK: G. MARTIN 16 JAN 2007
APPD: G. MARTIN 16 JAN 2007

DIMENSIONS: mm
TOLERANCES UNLESS OTHERWISE SPECIFIED:
0 PLC ±0.3
1 PLC ±0.10
2 PLC ±0.10
3 PLC ±0.10
4 PLC ±0.10
ANGLES ±0.1

MATERIAL: SEE TABLE
FINISH: -

WEIGHT: 5.53 grams
CUSTOMER DRAWING

NAME: CONNECTOR ASSEMBLY, FEMALE, 6 POSITION SEALED, 1.2mm MCON
SIZE: 4:1
SCALE: 4:1
SHEET: 1 OF 2
REV: B2

TE Connectivity

REVISIONS				
P.	LTM	DESCRIPTION	DATE	OWN APVD
-	-	SEE SHEET 1	-	-

ISOMETRIC VIEWS

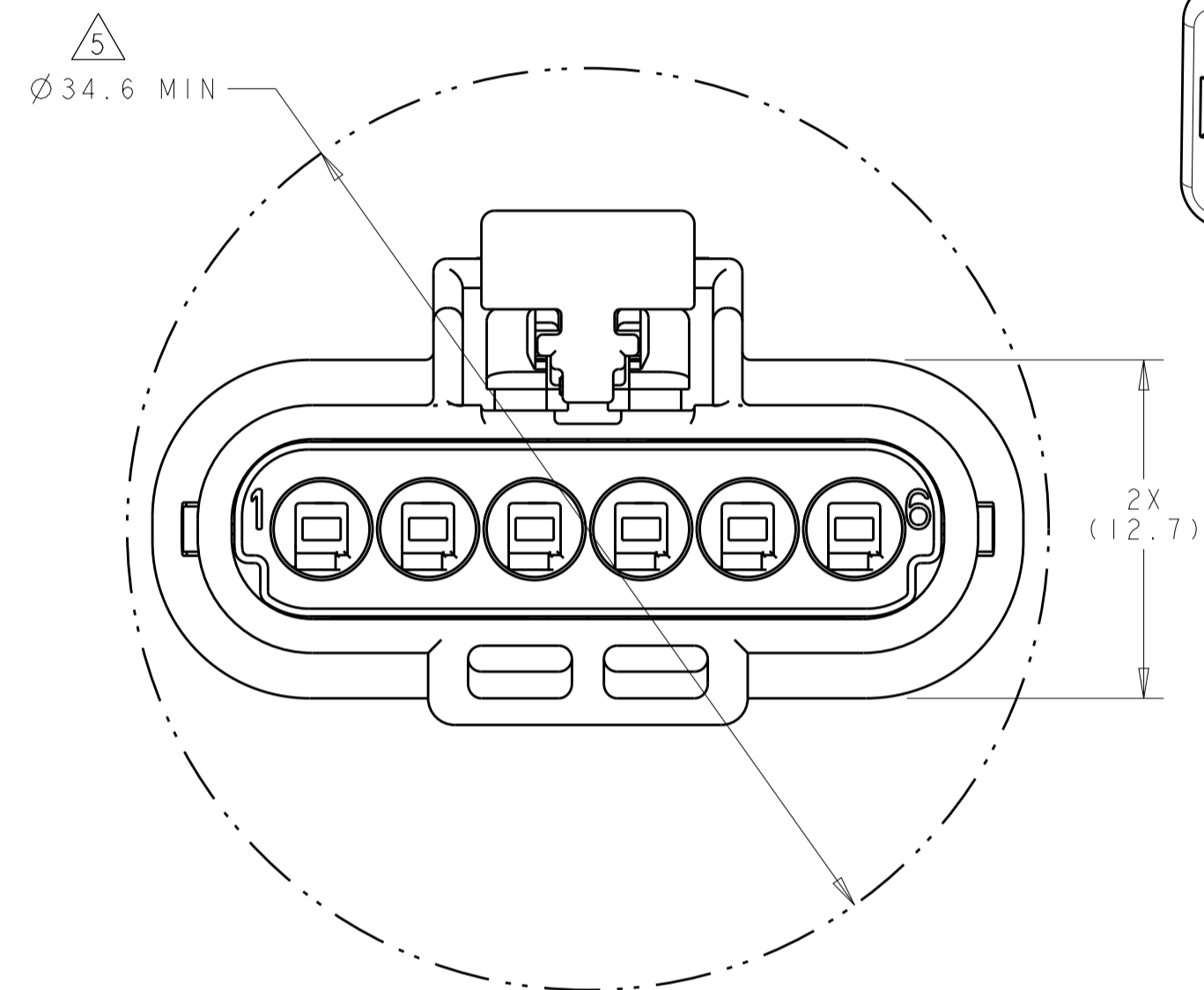
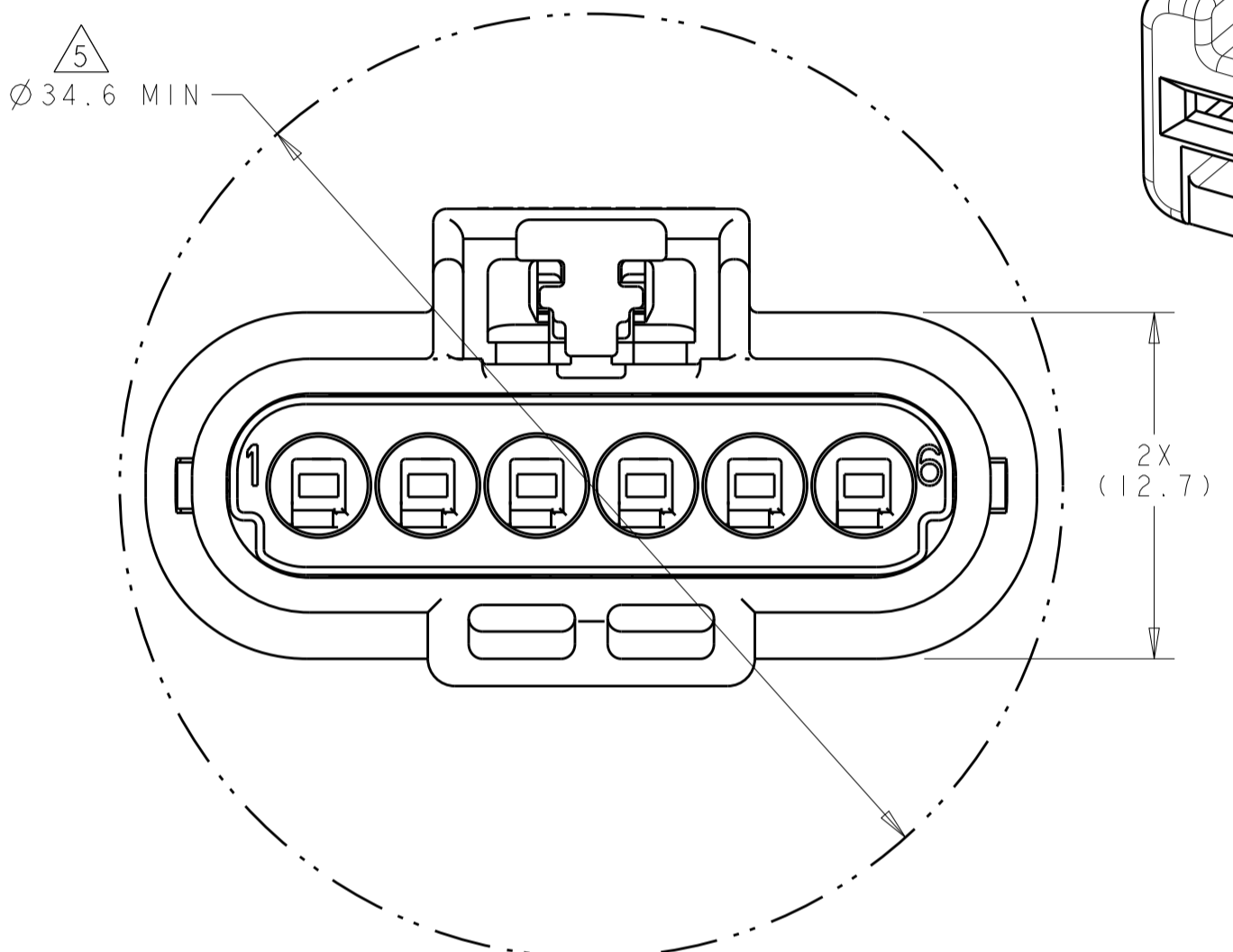
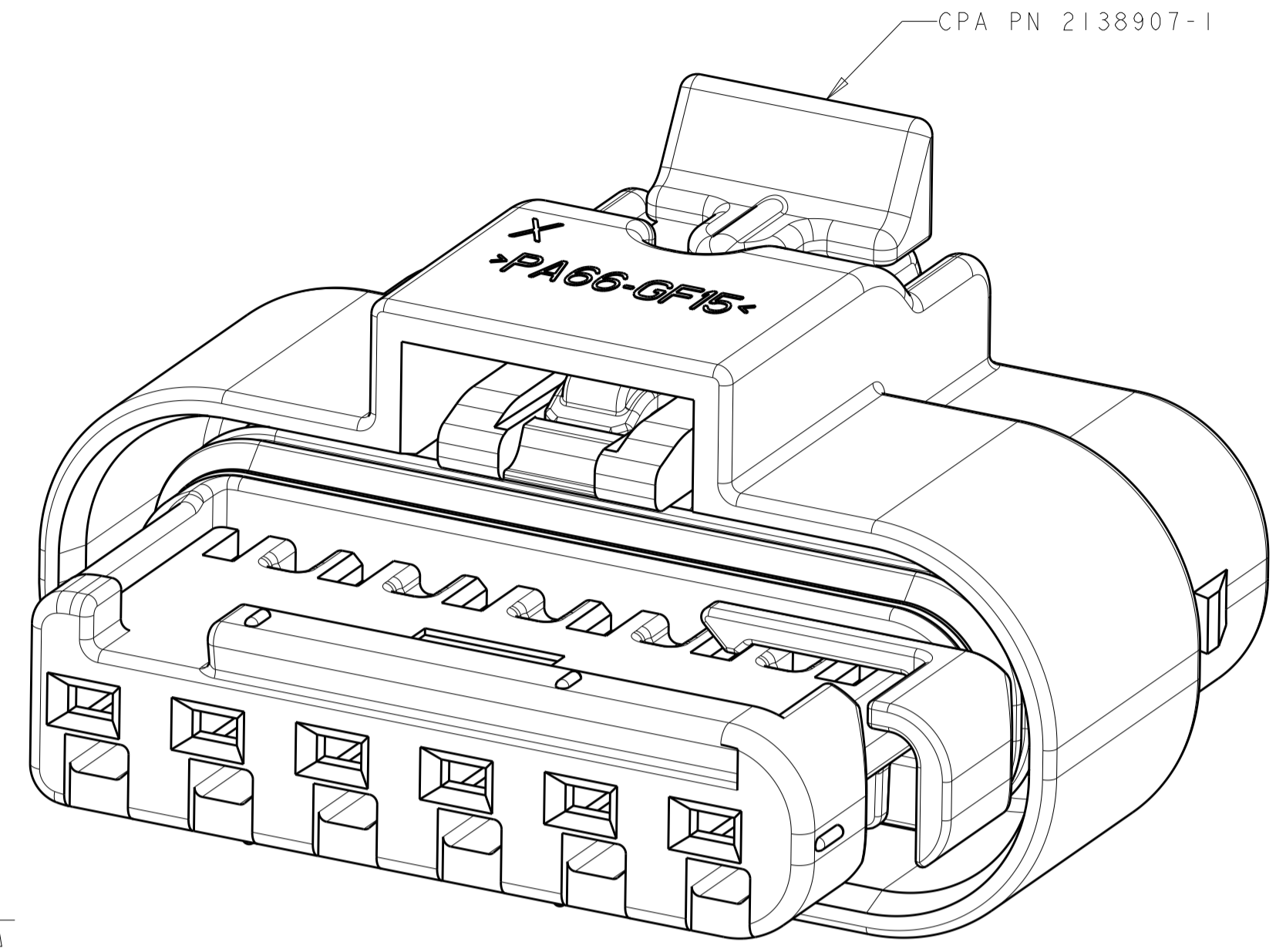
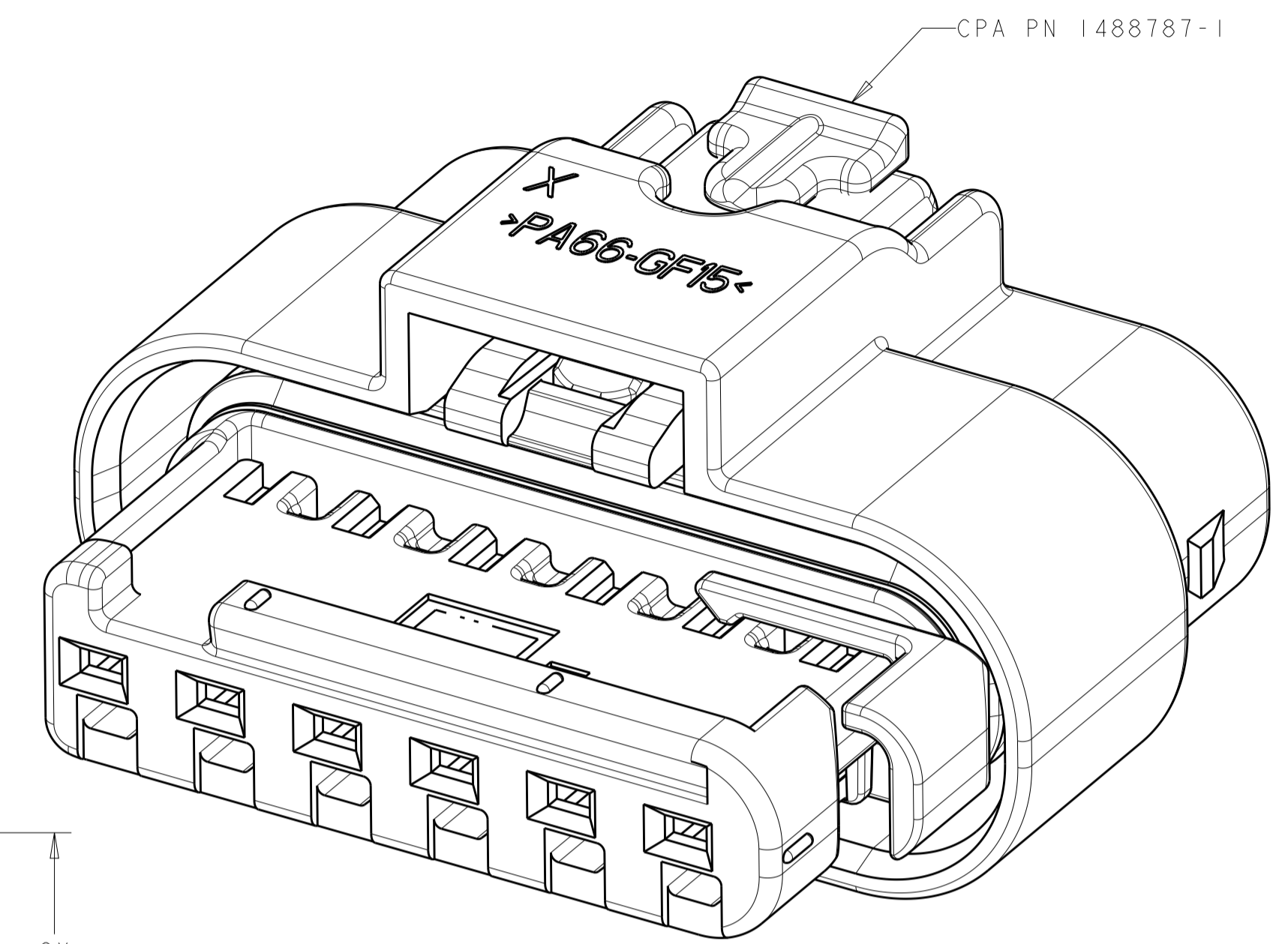

P/N 1924292-5 SHOWN
SCALE 6:1

P/N 4-1924292-1 SHOWN
SCALE 6:1

FEED THROUGH CONDITION

FEED THROUGH CONDITION

THIS DRAWING IS A CONTROLLED DOCUMENT.		OWN: M. HITCHCOCK 16 JAN 2007	
DIMENSIONS: mm		CHK: G. MARTIN 16 JAN 2007	
TOLERANCES UNLESS OTHERWISE SPECIFIED:		APVD: G. MARTIN 16 JAN 2007	NAME: CONNECTOR ASSEMBLY, FEMALE, 6 POSITION SEALED, 1.2mm MCON
0 PLC ±	1 PLC ±0.3	PRODUCT SPEC	SIZE: CAGE CODE DRAWING NO. RESTRICTED TO
2 PLC ±0.10	3 PLC ±	APPLICATION SPEC	WEIGHT: 5.53 grams A100779C=1924292
4 PLC ±	ANGLES ±	SEE NOTES	CUSTOMER DRAWING
MATERIAL: SEE TABLE	FINISH: -	SCALE: 4:1	SHEET 2 OF 2 REV B2