



ELECTRONICS, INC.  
 44 FARRAND STREET  
 BLOOMFIELD, NJ 07003  
 (973) 748-5089  
<http://www.nteinc.com>

## NTE3056 thru NTE3059 0.3" Single Digit Numeric Display, Seven Segment, Common Cathode

**Description:**

The NTE3056 through NTE3059 are 0.3 inch (7.62mm) height single digit, seven segment, common cathode displays. The NTE3056 and NTE3057 utilize LED chips which are made from GaAsP on a GaAs substrate. The NTE3058 utilizes LED chips which are made from GaAsP on a transparent GaP substrate. The NTE3059 utilizes LED chips which are made from GaP on a transparent GaP substrate.

**Features:**

- 0.3 Inch (7.62mm) Digit Height
- Choice of Four Bright Colors:
  - Super Red NTE3056
  - Red - NTE3057
  - Orange - NTE3058
  - Green - NTE3059
- Low Power Requirement
- Excellent Characters Appearance
- Categorized for Luminous Intensity
- IC Compatible
- Easy Mounting on PC Board or Sockets

**Absolute Maximum Ratings:** ( $T_A = +25^\circ\text{C}$  unless otherwise specified)

Power Dissipation (Per Segment), $P_T$	
NTE3056, NTE3057	100mW
NTE3058, NTE3059	75mW
Peak Forward Current (Per Segment, 1/10 Duty Cycle, 0.1ms Pulse Width), $I_{Fpeak}$	100mA
Continuous Forward Current (Per Segment), $I_F$	
NTE3056, NTE3057	40mA
NTE3058, NTE3059	25mA
Derate Linearly from 25°C (Per Segment)	
NTE3056, NTE3057	0.40mA/°C
NTE3058, NTE3059	0.30mA/°C
Reverse Voltage (Per Segment), $V_R$	5V
Operating Temperature Range, $T_{opr}$	
NTE3056, NTE3057	-40° to +80°C
All Other Devices	-25° to +85°C
Storage Temperature Range, $T_{stg}$	
NTE3056, NTE3057	-40° to +80°C
All Other Devices	-25° to +85°C
Lead Temperature (During Solder, 1/16" Below Seating Plane, 3sec max), $T_L$	+260°C

**Electrical/Optical Characteristics:** ( $T_A = +25^\circ\text{C}$  unless otherwise specified)

Parameter	Symbol	Test Conditions	Min	Typ	Max	Unit
Average Luminous Intensity NTE3056, NTE3057	$I_V$	$I_F = 20\text{mA}$	-	10.5	14	mcd
NTE3058, NTE3059	$I_V$	$I_F = 10\text{mA}$	800	2000	-	$\mu\text{cd}$
Peak Emission Wavelength NTE3056, NTE3057	$\lambda_P$	$I_F = 20\text{mA}$	655	660	665	nm
NTE3058			-	630	-	nm
NTE3059			-	565	-	nm
Spectral Line Half-Width NTE3056, NTE3057	$\Delta\lambda$	$I_F = 20\text{mA}$	19	24	29	nm
NTE3058			-	40	-	nm
NTE3059			-	30	-	nm
Forward Voltage, Any Segment or D.P. NTE3056, NTE3057	$V_F$	$I_F = 20\text{mA}$	1.6	1.85	2.4	V
NTE3058, NTE3059			-	2.1	2.8	V
Reverse Current, Any Segment or D.P. All Devices	$I_R$	$V_R = 5\text{V}$	-	-	100	$\mu\text{A}$
Luminous Intensity Matching Ratio All Devices <b>EXCEPT</b> NTE3056	$I_{V-m}$	$I_F = 20\text{mA}$	-	-	2:1	

**Pin Connection Diagram**

**NTE3056, NTE3058, NTE3059**

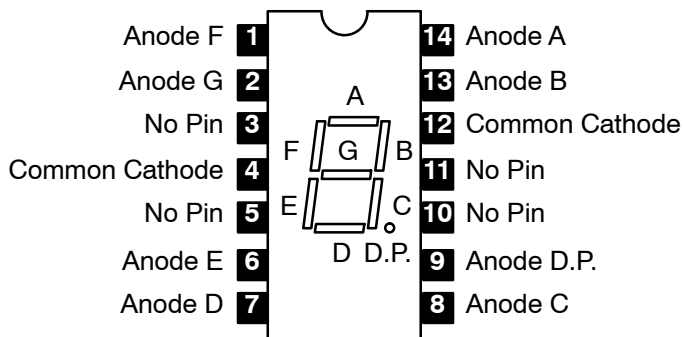

**NTE3057**

