

# CLC426

## Wideband, Low Noise, Voltage Feedback Op Amp

### General Description

The National CLC426 combines an enhanced voltage feedback architecture with an advanced complimentary bipolar process to provide a high speed op amp with very low noise ( $1.6\text{nV}/\sqrt{\text{Hz}}$  &  $2.0\text{pA}/\sqrt{\text{Hz}}$ ) and distortion ( $-62\text{dBc}/-68\text{dBc}$  2nd/3rd harmonics at  $1V_{PP}$  and  $10\text{MHz}$ ).

Providing a wide  $230\text{MHz}$  gain bandwidth product, a fast  $400\text{V}/\mu\text{s}$  slew rate and very quick  $16\text{ns}$  settling time to  $0.05\%$ , the CLC426 is the ideal choice for high speed applications requiring a very wide dynamic range such as an input buffer for high resolution analog-to-digital converters.

The CLC426 is internally compensated for gains  $\geq 2V/V$  and can easily be externally compensated for unity gain stability in applications such as wideband low noise integrators. The CLC426 is also equipped with external supply current adjustment which allows the user to optimize power, bandwidth, noise and distortion performance for each application.

The CLC426's combination of speed, low noise and distortion and low dc errors will allow high speed signal conditioning applications to achieve the highest signal-to-noise performance. To reduce design times and assist board layout, the CLC426 is supported by an evaluation board and SPICE simulation model available from National.

For even higher gain-bandwidth voltage-feedback op amps see the  $1.9\text{GHz}$  CLC425 ( $A_V \geq 10V/V$ ) or the  $5.0\text{GHz}$  CLC422 ( $A_V \geq 30V/V$ ).

Enhanced Solutions (Military/Aerospace)

SMD Number: 5962-94597

\*Space level versions also available.

\*For more information, visit <http://www.national.com/mil>

- Ultra low input voltage noise:  $1.6\text{nV}/\sqrt{\text{Hz}}$
- Very low harmonic distortion:  $-62/-68\text{dBc}$
- Fast slew rate:  $400\text{V}/\mu\text{s}$
- Adjustable supply current
- Dual  $\pm 2.5$  to  $\pm 5\text{V}$  or single  $5$  to  $12\text{V}$  supplies
- Externally compensatable

### Applications

- Active filters & integrators
- Ultrasound
- Low power portable video
- ADC/DAC buffer
- Wide dynamic range amp
- Differential amps
- Pulse/RF amp

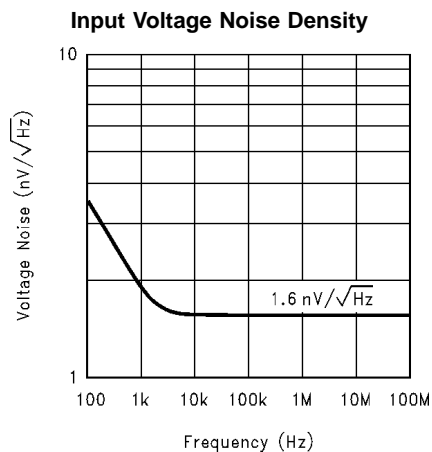

### Features

- Wide gain-bandwidth product:  $230\text{MHz}$

### Connection Diagram

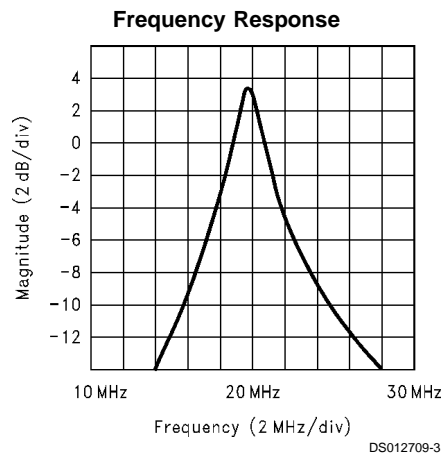
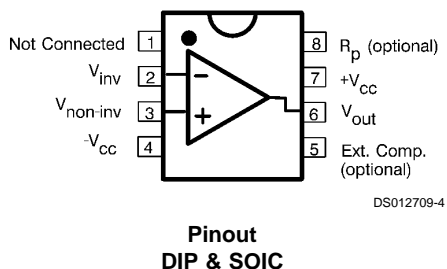

## Typical application

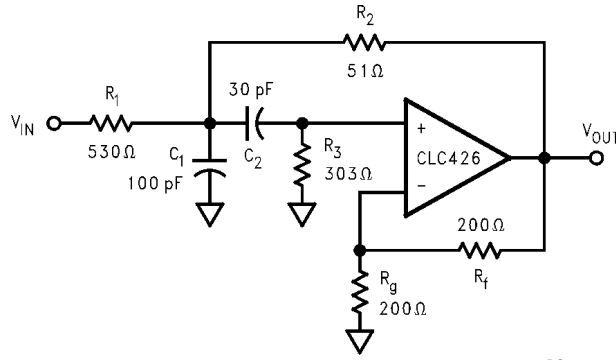

DS012709-2

Wide Dynamic Range Sallen-Key Band Pass Filter 2nd-Order (20MHz, Q = 10, G = 2)

## Ordering Information

Package	Temperature Range Industrial	Part Number	Package Marking	NSC Drawing
8-Pin Plastic DIP	-40°C to +85°C	CLC426AJP	CLC426AJP	N08E
8-Pin Plastic SOIC	-40°C to +85°C	CLC426AJE	CLC426AJE	M08A

**Absolute Maximum Ratings** (Note 1)

If Military/Aerospace specified devices are required, please contact the National Semiconductor Sales Office/Distributors for availability and specifications.

Supply Voltage  $\pm 7V$   
Short Circuit Current (Note 6)

Common-Mode Input Voltage  $\pm V_{CC}$   
Differential Input Voltage  $\pm 10V$   
Maximum Junction Temperature  $+150^{\circ}C$   
Storage Temperature  $-65^{\circ}C$  to  $+150^{\circ}C$   
Lead Temperature (Soldering 10 sec)  $+300^{\circ}C$   
ESD 2000V

**Electrical Characteristics**

( $V_{CC} = \pm 5$ ;  $A_V = +2V/V$ ;  $R_f = 100\Omega$ ;  $R_L = 100\Omega$ ; unless noted)

Notes	Parameters	Conditions	Typ	Max/Min Ratings (Note 2)			Units
	Ambient Temperature	CLC426	$+25^{\circ}C$	$+25^{\circ}C$	0 to $+70^{\circ}C$	$-40$ to $+85^{\circ}C$	
<b>Frequency Domain Response</b>							
	Gain Bandwidth Product	$V_{OUT} < 0.5V_{PP}$	230	170	120	100	MHz
(Note 4), (Note 5), (Note 8)	-3dB Bandwidth, $A_V = +2$	$V_{OUT} < 0.5V_{PP}$	130	90	70	55	MHz
		$V_{OUT} < 5.0V_{PP}$	50	25	22	20	MHz
	Gain Flatness	$V_{OUT} < 0.5V_{PP}$					
(Note 4), (Note 8)	Peaking	DC to 200MHz	0.6	1.5	2.2	2.5	dB
(Note 4), (Note 8)	Rolloff	DC to 30MHz	0.0	0.6	1.0	1.0	dB
	Linear Phase Deviation	DC to 30MHz	0.2	1.0	1.5	1.5	deg
<b>Time Domain Response</b>							
	Rise and Fall Time	1V Step	2.3	3.5	5.0	6.5	ns
	Settling Time	2V Step to 0.05%	16	20	24	24	ns
	Overshoot	1V Step	5	15	15	18	%
	Slew Rate	5V Step	400	300	275	250	V/ $\mu$ s
<b>Distortion And Noise Response</b>							
(Note 3)	2nd Harmonic Distortion	$1V_{PP}, 10MHz$	-62	-52	-47	-45	dBc
(Note 3)	3rd Harmonic Distortion	$1V_{PP}, 10MHz$	-68	-58	-54	-54	dBc
	Equivalent Input Noise	Op Amp Only					
	Voltage	1MHz to 100MHz	1.6	2.0	2.3	2.6	nV/ $\sqrt{Hz}$
	Current	1MHz to 100MHz	2.0	3.0	3.6	4.6	pA/ $\sqrt{Hz}$
<b>Static DC Performance</b>							
	Open-Loop Gain	DC	64	60	54	54	dB
(Note 3)	Input Offset Voltage		1.0	2.0	2.8	2.8	mV
	Average Drift		3	-	10	10	$\mu$ V/ $^{\circ}C$
(Note 3)	Input Bias Current		5	25	40	65	$\mu$ A
	Average Drift		90	-	600	700	nA/ $^{\circ}C$
(Note 3)	Input Offset Current		0.3	3	5	5	$\mu$ A
	Average Drift		5	-	25	50	nA/ $^{\circ}C$
(Note 4)	Power-Supply Rejection Ratio	DC	73	65	60	60	dB
	Common-Mode Rejection Ratio	DC	70	62	57	57	dB
(Note 3)	Supply Current	Pin #8 Open, $R_L = \infty$	11	12	13	15	mA
<b>Miscellaneous Performance</b>							
	Input Resistance	Common-Mode	500	250	125	125	k $\Omega$
		Differential-Mode	750	200	50	25	k $\Omega$
	Input Capacitance	Common-Mode	2.0	3.0	3.0	3.0	pF
		Differential-Mode	2.0	3.0	3.0	3.0	pF

# Electrical Characteristics (Continued)

( $V_{CC} = \pm 5$ ;  $A_V = +2V/V$ ;  $R_f = 100\Omega$ ;  $R_L = 100\Omega$ ; unless noted)

Notes	Parameters	Conditions	Typ	Max/Min Ratings (Note 2)				Units
<b>Miscellaneous Performance</b>								
	Output Resistance	Closed Loop	0.07	0.1	0.2	0.2	$\Omega$	
	Output Voltage Range	$R_L = \infty$	$\pm 3.8$	$\pm 3.5$	$\pm 3.3$	$\pm 3.3$	V	
		$R_L = 100\Omega$	$\pm 3.5$	$\pm 3.2$	$\pm 2.6$	$\pm 1.3$	V	
	Input Voltage Range	Common Mode	$\pm 3.7$	$\pm 3.5$	$\pm 3.3$	$\pm 3.3$	V	
	Output Current		$\pm 70$	$\pm 50$	$\pm 40$	+35, -20	mA	

**Note 1:** "Absolute Maximum Ratings" are those values beyond which the safety of the device cannot be guaranteed. They are not meant to imply that the devices should be operated at these limits. The table of "Electrical Characteristics" specifies conditions of device operation.

**Note 2:** Min/max ratings are based on product characterization and simulation. Individual parameters are tested as noted. Outgoing quality levels are determined from tested parameters.

**Note 3:** J-level: spec. is 100% tested at +25°C, sample at 85°C. L-level: spec. is 100% wafer probed at 25°C.

**Note 4:** J-level: spec is sample tested at 25°C

**Note 5:** Minimum table stable gain with out external compensation is +2 or -1V/V, the CLC426 unity-gain stable with external compensation.

**Note 6:** Output is short circuit protected to ground, however maximum reliability is obtained if output current does not exceed 160mA

**Note 7:** See test for compensation techniques.

**Note 8:** Spec is guaranteed to 0.5V<sub>PP</sub> but tested with 0.1V<sub>PP</sub>

## Typical Performance Characteristics ( $T_A = 25^\circ\text{C}$ , $\pm V_{CC} = \pm 5\text{V}$ , $A_V = +2$ , $R_f = 100\Omega$ , $R_L = 100\Omega$ , unless noted)

### Non-Inverting Frequency Response

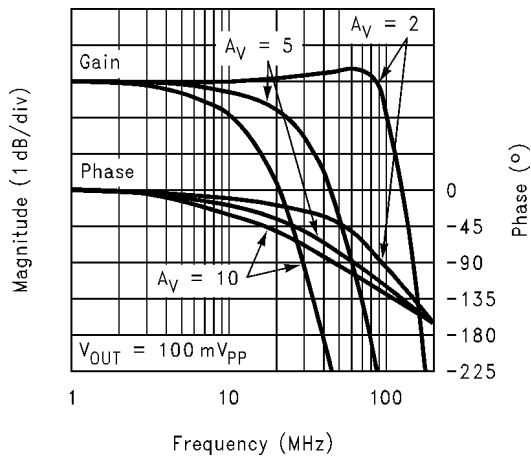

### Inverting Frequency Response

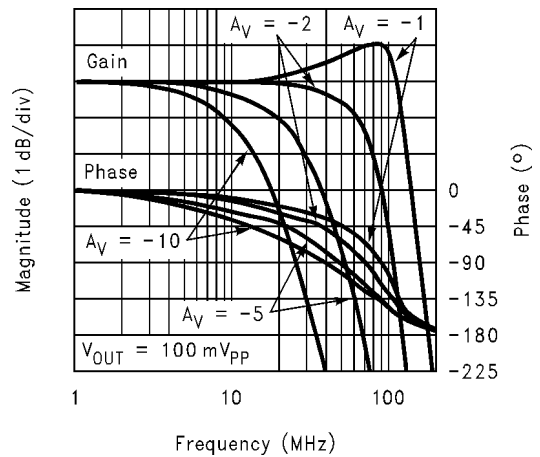

### Frequency Response vs. Load Resistance

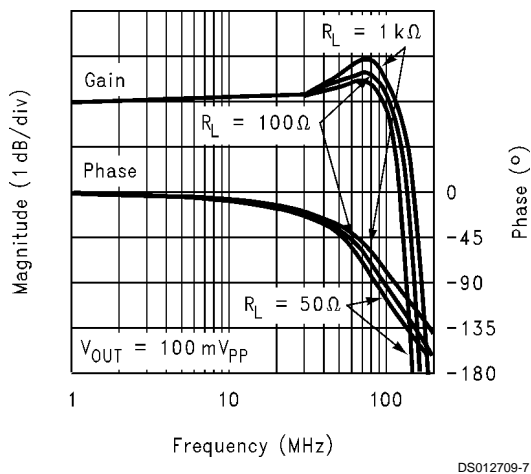

### Open-Loop Gain vs. Supply Current

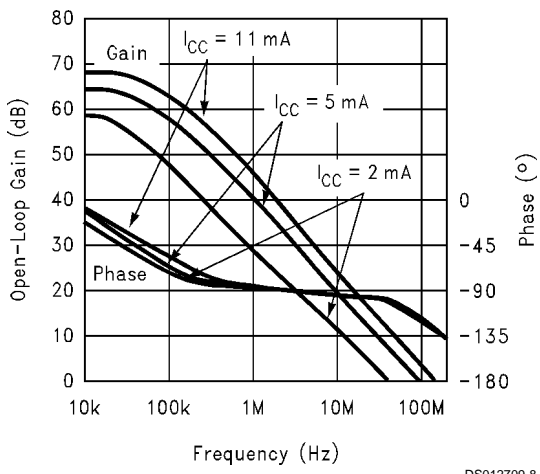

**Typical Performance Characteristics** ( $T_A = 25^\circ\text{C}$ ,  $\pm V_{CC} = \pm 5\text{V}$ ,  $A_V = +2$ ,  $R_f = 100\Omega$ ,  $R_L = 100\Omega$ , unless noted) (Continued)

**Open-Loop Gain vs. Compensation Cap.**

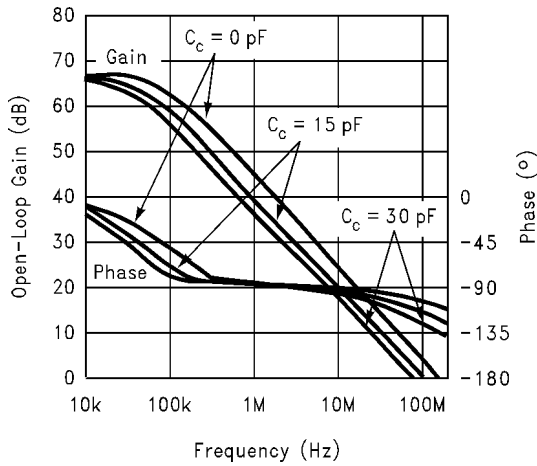

DS012709-9

**Frequency Response vs. Compensation Cap.**

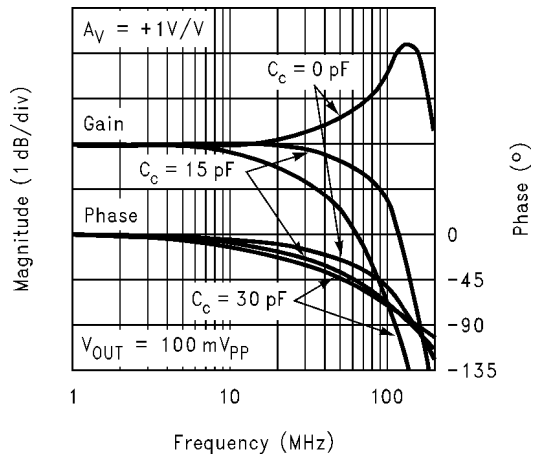

DS012709-10

**Supply Current vs.  $R_p$**

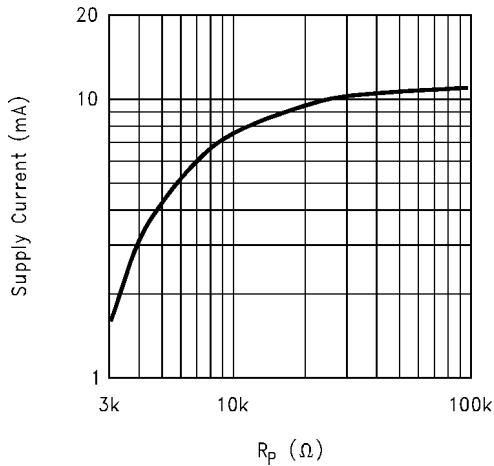

DS012709-11

**Voltage Noise vs. Supply Current**

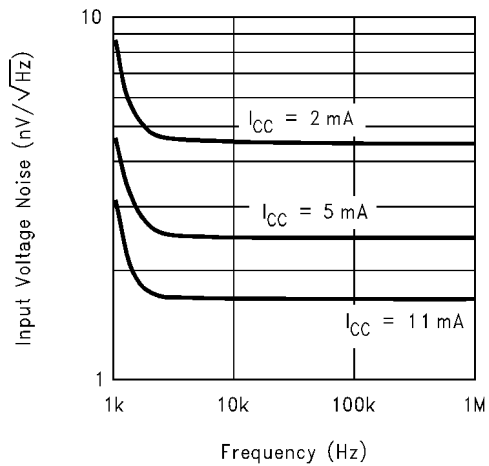

DS012709-12

**Frequency Response vs. Output Amplitude**

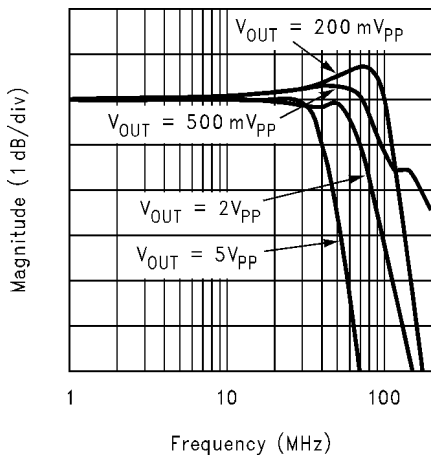

DS012709-13

**Gain-Bandwidth Product vs Supply Current**

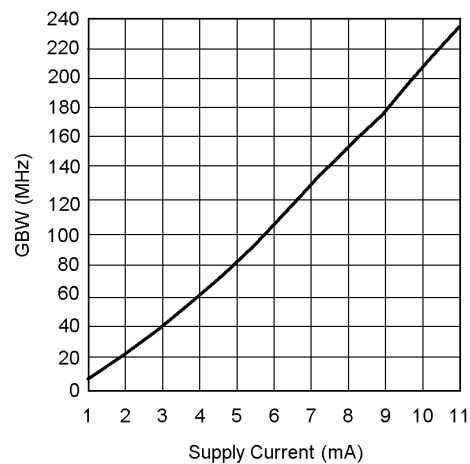

DS012709-14

**Typical Performance Characteristics** ( $T_A = 25^\circ\text{C}$ ,  $\pm V_{CC} = \pm 5\text{V}$ ,  $A_V = +2$ ,  $R_f = 100\Omega$ ,  $R_L = 100\Omega$ , unless noted) (Continued)

**Current Noise vs. Supply Current**

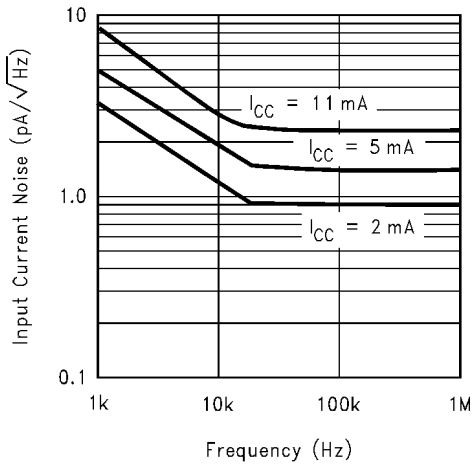

DS012709-15

**Maximum Output Voltage vs. Load**

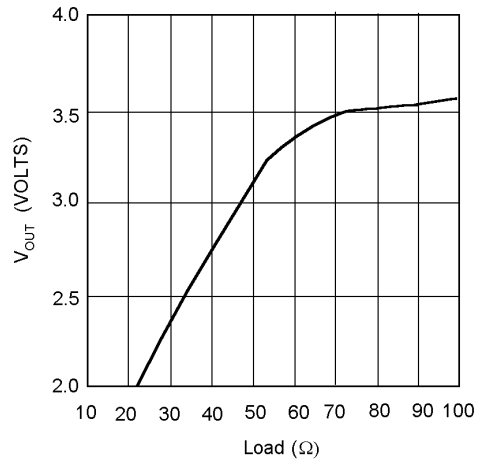

DS012709-16

**CMRR and PSRR**

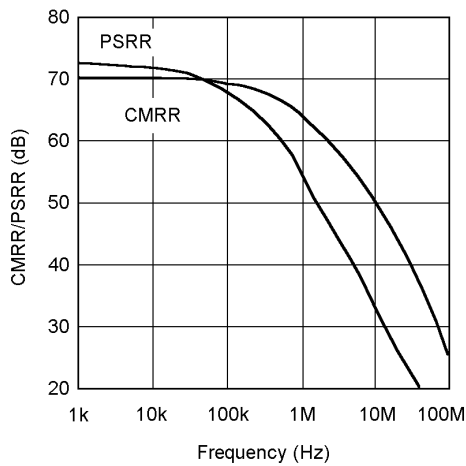

DS012709-17

**Closed-Loop Output Resistance**

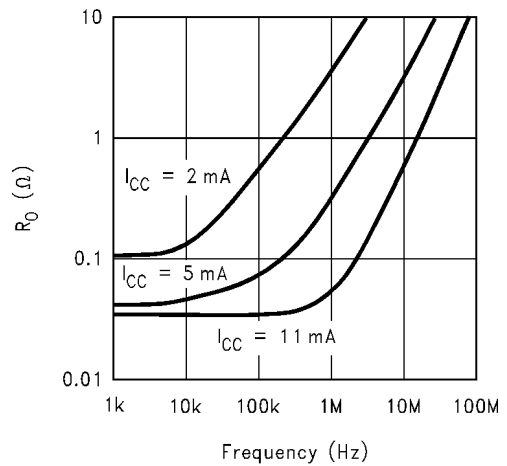

DS012709-18

**Typical DC Errors vs. Temperature**

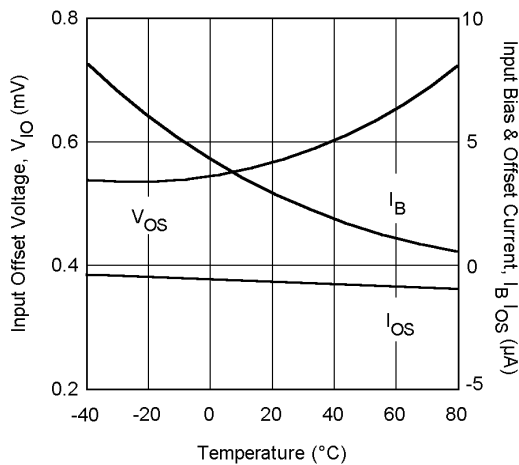

DS012709-19

**Short-Term Settling Time**

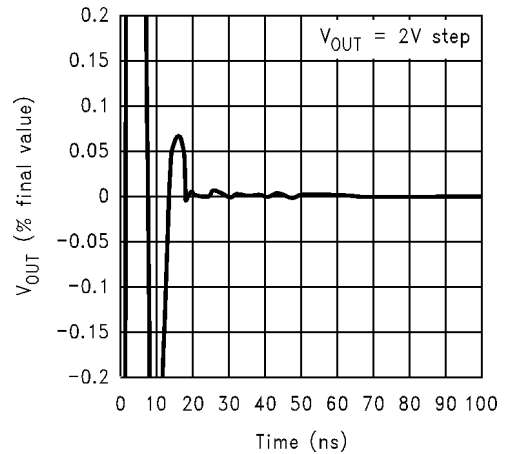

DS012709-20

**Typical Performance Characteristics** ( $T_A = 25^\circ\text{C}$ ,  $\pm V_{CC} = \pm 5\text{V}$ ,  $A_V = +2$ ,  $R_f = 100\Omega$ ,  $R_L = 100\Omega$ , unless noted) (Continued)

**Frequency Response vs. Capacitive Load**

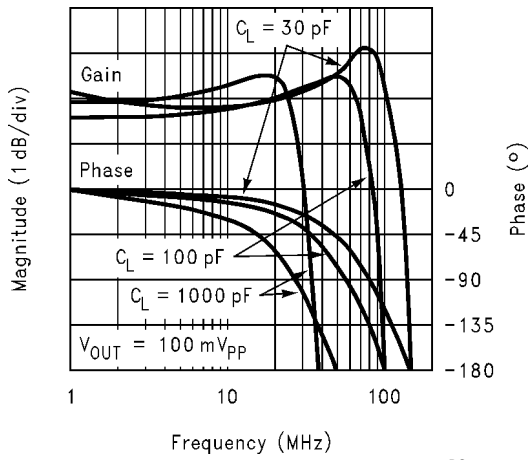

DS012709-21

**Setting Time vs. Capacitive Load**

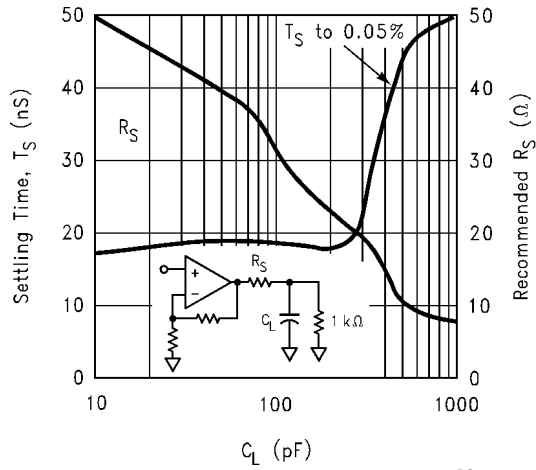

DS012709-22

**Pulse Response ( $V_{OUT} = 100\text{mV}_{PP}$ )**

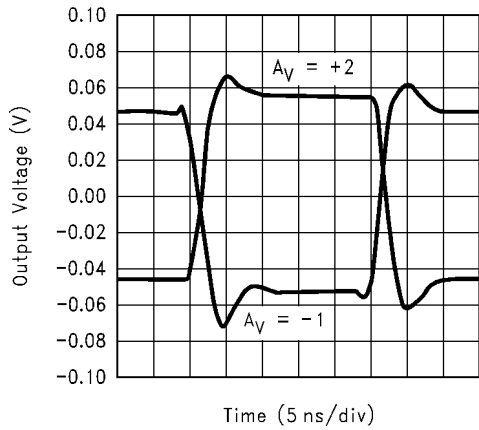

DS012709-23

**Pulse Response ( $V_{OUT} = 2\text{V}_{PP}$ )**

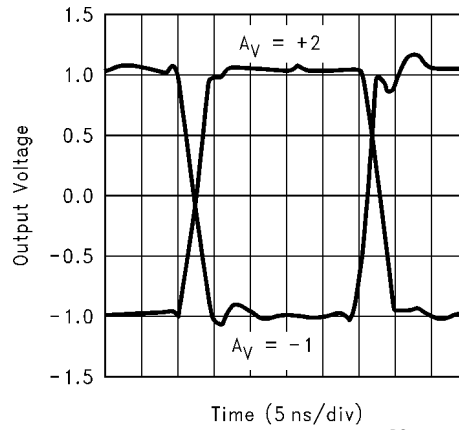

DS012709-24

**2nd Harmonic Distortion vs. Output Power**

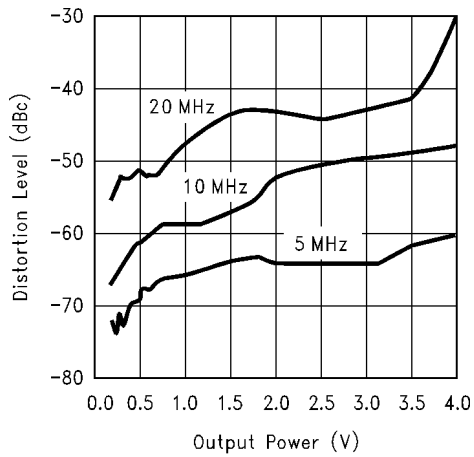

DS012709-25

**2nd Harmonic Distortion**

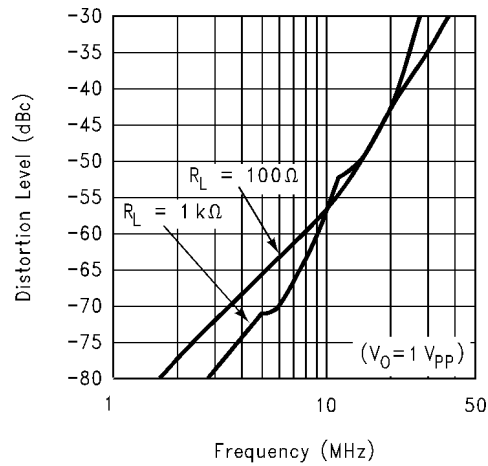

DS012709-26

## Typical Performance Characteristics

( $T_A = 25^\circ\text{C}$ ,  $\pm V_{CC} = \pm 5\text{V}$ ,  $A_V = +2$ ,  $R_f = 100\Omega$ ,  $R_L = 100\Omega$ , unless noted) (Continued)

### 3rd Harmonic Distortion

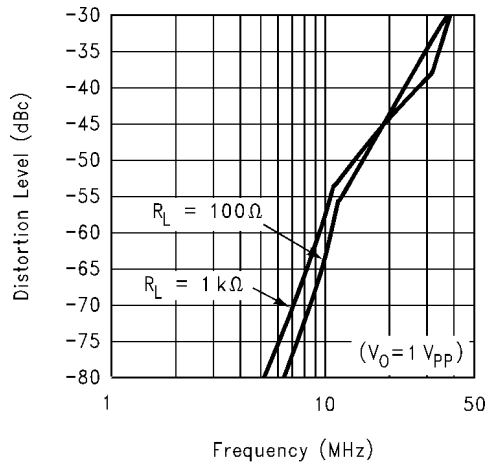

### 3rd Harmonic Distortion vs. Output Power

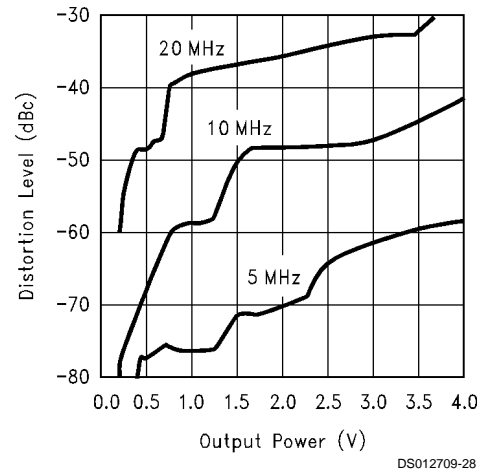

## Application Discussion

### Introduction

The CLC426 is a wide bandwidth voltage-feedback operational amplifier that is optimized for applications requiring wide dynamic range. The CLC426 features adjustable supply current and external compensation for the added flexibility of tuning its performance for demanding applications. The Typical Performance section illustrates many of the performance trade-offs. Although designed to operate from  $\pm 5\text{V}$  power supplies, the CLC426 is equally impressive operating from a single  $+5\text{V}$  supply. The following discussion will enable the proper selection of external components for optimum device performance in a variety of applications.

### External Compensation

The CLC426 is stable for noise gains  $\geq 2\text{V/V}$ . For unity-gain operation, the CLC426 requires an external compensation capacitor (from pin 5 to ground). The plot located in the Typical Performance section labeled "Frequency Response vs. Compensation Cap." illustrates the CLC426's typical AC response for different values of compensation capacitor. From the plot it is seen that a value of  $15\text{pF}$  produces the optimal response of the CLC426 at unity gain. The plot labeled "Open-Loop Gain vs. Compensation Cap." illustrates the CLC426's open-loop behavior for various values of compensation capacitor. This plot also illustrates one technique of bandlimiting the device by reducing the open-loop gain resulting in lower closed-loop bandwidth. *Figure 1* shows the effect of external compensation on the CLC426's pulse response.

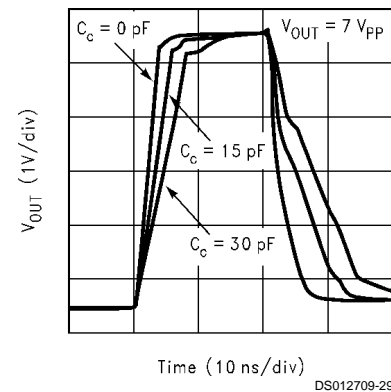

FIGURE 1.

### Supply Current Adjustment

The CLC426's supply current can be externally adjusted downward from its nominal value to less than  $2\text{mA}$  by adding an optional resistor ( $R_p$ ) between pin 8 and the negative supply as shown in *Figure 2*. The plot labeled "Open-Loop Gain vs. Supply Current" illustrates the influence that supply current has over the CLC426's open-loop response. From the plot it is seen that the CLC426 can be compensated for unity-gain stability by simply lowering its supply current. Therefore lowering the CLC426's supply current effectively reduces its open-loop gain to the point that there is adequate phase margin at unity gain crossover. The plot labeled "Supply Current vs.  $R_p$ " provides the means for selecting the value of  $R_p$  that produces the desired supply current. The curve in the plot represents nominal processing but a  $\pm 12\%$  deviation over process can be expected. The two plots labeled "Voltage Noise vs. Supply Current" and "Current Noise vs. Supply Current" illustrate the CLC426 supply current's effect over its input-referred noise characteristics.



## Application Discussion (Continued)

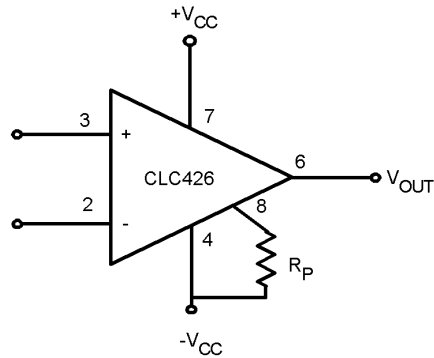

FIGURE 2.

DS012709-30

### Driving Capacitive Loads

The CLC426 is designed to drive capacitive loads with the addition of a small series resistor placed between the output and the load as seen in *Figure 3*. Two plots located in the Typical Performance section illustrate this technique for both frequency domain and time domain applications. The plot labeled “Frequency Response vs. Capacitive Load” shows the CLC426’s resulting AC response to various capacitive loads. The values of  $R_s$  in this plot were chosen to maximize the CLC426’s AC response (limited to  $\leq 1$ dB peaking).

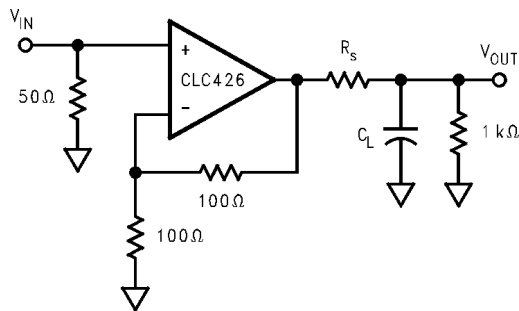

FIGURE 3.

DS012709-31

The second plot labeled “Settling Time vs. Capacitive Load” provides the means for the selection of the value of  $R_s$  which minimizes the CLC426’s settling time. As seen from the plot, for a given capacitive load  $R_s$  is chosen from the curve labeled “ $R_s$ ”. The resulting settling time to 0.05% can then be estimated from the curve labeled “ $T_s$  to 0.05%”. The plot of *Figure 4* shows the CLC426’s pulse response for various capacitive loads where  $R_s$  has been chosen from the plot labeled “Settling Time vs. Capacitive Load”.

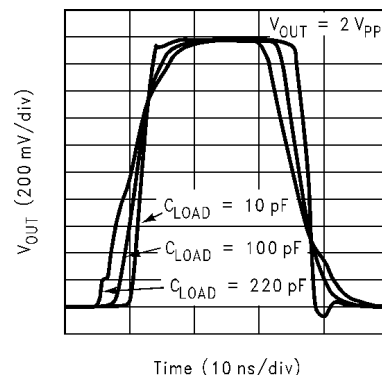

FIGURE 4.

DS012709-32

### Faster Settling

The circuit of *Figure 5* shows an alternative method for driving capacitive loads that results in quicker settling times. The small series resistor,  $R_s$ , is used to decouple the CLC426’s open-loop output resistance,  $R_{OUT}$ , from the load capacitance. The small feedback capacitance,  $C_f$ , is used to provide a high frequency bypass between the output and inverting input. The phase lead introduced by  $C_f$  compensates for the phase lag due to  $C_L$  and therefore restores stability. The following equations provide values of  $R_s$  and  $C_f$  for a given load capacitance and closed-loop amplifier gain.

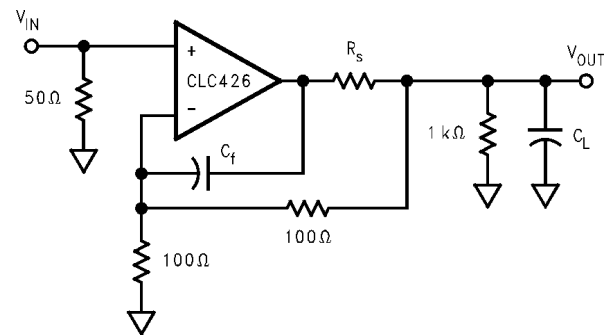

FIGURE 5.

DS012709-33

$$R_s = R_{OUT} \left( \frac{R_f}{R_g} \right); \text{ where } R_{OUT} \approx 6\Omega \quad (1)$$

$$C_f = \left[ 1 + \left[ \frac{R_f}{R_g} \right] \right]^2 C_L \left[ \frac{R_{OUT}}{R_g} \right] \quad (2)$$

The plot in *Figure 6* shows the result of the two methods of capacitive load driving mentioned above while driving a 100 pF||1kΩ load.

## Application Discussion (Continued)

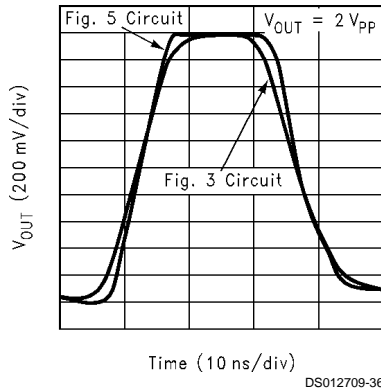
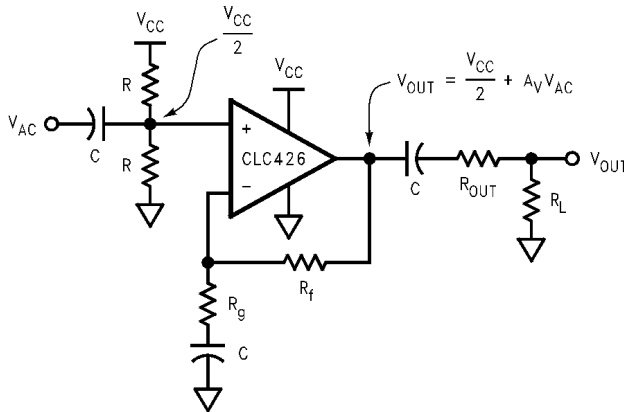

FIGURE 6.

### Single Supply Operation

The CLC426 can be operated with single power supply as shown in Figure 7. Both the input and output are capacitively coupled to set the dc operating point.



DS012709-37

FIGURE 7.

### DAC Output Buffer

The CLC426's quick settling, wide bandwidth and low differential input capacitance combine to form an excellent I-to-V converter for current output DACs in such applications as reconstruction video. The circuit of Figure 8 implements a low noise transimpedance amplifier commonly used to buffer high speed current output devices. The transimpedance gain is set by  $R_f$ . A feedback capacitor,  $C_f$ , is needed in order to compensate for the inductive behavior of the closed-loop frequency response of this type of circuit.

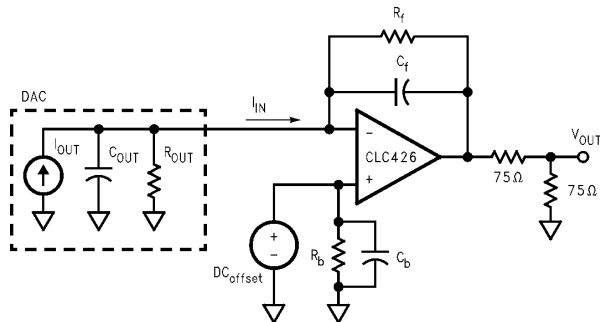

DS012709-38

FIGURE 8.

Equation 3 shows a means of calculating the value of  $C_f$  which will provide conditions for a maximally flat signal frequency response with approximately  $65^\circ$  phase margin and 5% step response overshoot. Notice that  $C_t$  is the sum of the DAC output capacitance and the differential input capacitance of the CLC426 which is located in its Electrical Characteristics Table. Notice also that CLC426's gain bandwidth product (GBW) is also located in the same table. Equation 5 provides the resulting signal bandwidth.

$$C_f = 2 \sqrt{\frac{C_t}{2\pi R_f \text{GBW}}} \quad (3)$$

$$C_T = C_{OUT} + C_{IN \text{ DIF}}$$

$$\text{signal bandwidth} = \frac{1}{2} \sqrt{\frac{\text{GBW}}{2\pi R_f C_t}} \quad (4)$$

### Sallen-Key Active Filters

The CLC426 is well suited for Sallen-Key type of active filters. shows the 2nd order Sallen-Key band-pass filter topology and design equations.

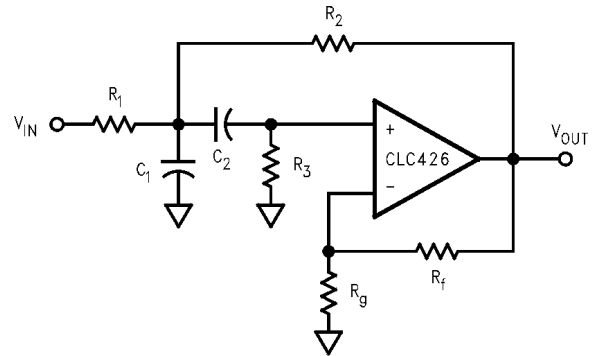

DS012709-43

$$C_2 = \frac{1}{5} C_1$$

$$G = 1 + \frac{R_f}{R_g}, \text{ desired mid-band gain}$$

$$R_1 = 2 \frac{Q}{GC_1 (2\pi f)}, \text{ where } f = \text{desired center frequency}$$

$$R_2 = \frac{GR_1 \left( \sqrt{1 + 4.8Q^2 - 2G + G^2 + 1} \right)}{4.8Q^2 - 2G + G^2}$$

$$R_3 = \frac{5GR_1 \left( \sqrt{1 + 4.8Q^2 - 2G + G^2 + G - 1} \right)}{4Q^2}$$

DS012709-44

FIGURE 9.

To design the band-pass, begin by choosing values for  $R_f$  and  $R_g$ , for example  $R_f = R_g = 200\Omega$ . Then chosen reasonable values for  $C_1$  and  $C_2$  (where  $C_1 = 5C_2$ ) and then compute  $R_1$ .  $R_2$  and  $R_3$  can then be computed. For optimum high frequency performance it is recommended that the resistor values fall in the range of  $10\Omega$  to  $1k\Omega$  and the capacitors be kept above  $10pF$ . The design can be further

## Application Discussion (Continued)

improved by compensating for the delay through the op amp. For further details on this technique, please request Application Note OA-21 from National Semiconductor Corporation.

### Printed Circuit Layout

Generally, a good high frequency layout will keep power supply and ground traces away from the inverting input and

output pins. Parasitic capacitances on these nodes to ground will cause frequency response peaking and possible circuit oscillation, see OA-15 for more information. National suggests the 730013 (through-hole) or the 730027 (SOIC) evaluation board as a guide for high frequency layout and as an aid in device testing and characterization.

**Physical Dimensions** inches (millimeters) unless otherwise noted

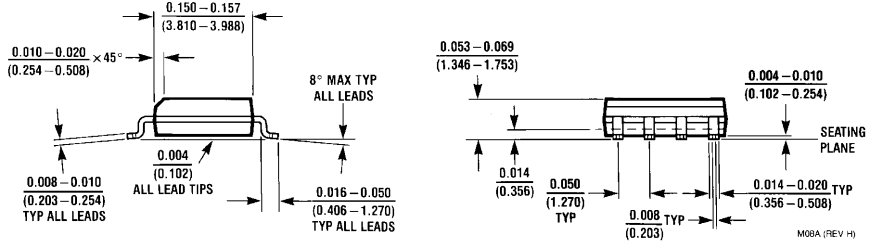
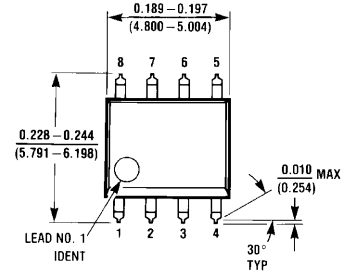

**8-Pin SOIC**  
NS Package Number M08A

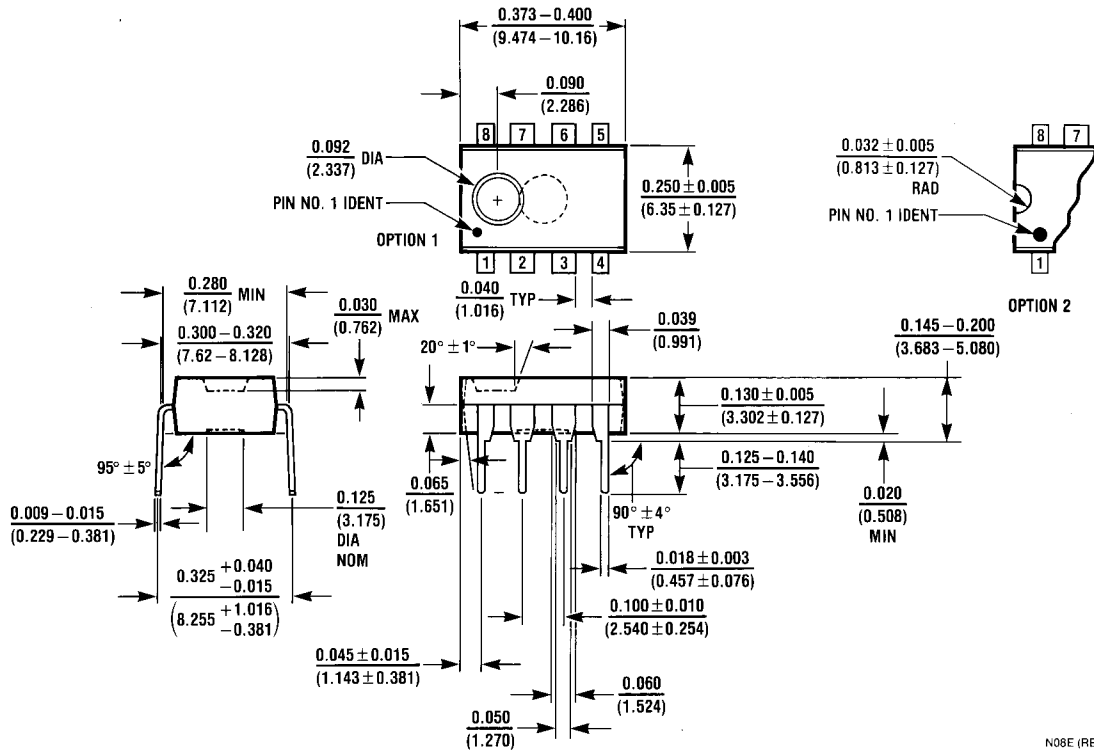

**8-Pin MDIP**  
NS Package Number N08E

## Notes

### LIFE SUPPORT POLICY

NATIONAL'S PRODUCTS ARE NOT AUTHORIZED FOR USE AS CRITICAL COMPONENTS IN LIFE SUPPORT DEVICES OR SYSTEMS WITHOUT THE EXPRESS WRITTEN APPROVAL OF THE PRESIDENT AND GENERAL COUNSEL OF NATIONAL SEMICONDUCTOR CORPORATION. As used herein:

1. Life support devices or systems are devices or systems which, (a) are intended for surgical implant into the body, or (b) support or sustain life, and whose failure to perform when properly used in accordance with instructions for use provided in the labeling, can be reasonably expected to result in a significant injury to the user.
2. A critical component is any component of a life support device or system whose failure to perform can be reasonably expected to cause the failure of the life support device or system, or to affect its safety or effectiveness.



**National Semiconductor Corporation**  
Americas  
Email: support@nsc.com

[www.national.com](http://www.national.com)

**National Semiconductor Europe**

Fax: +49 (0) 180-530 85 86  
Email: europe.support@nsc.com  
Deutsch Tel: +49 (0) 69 9508 6208  
English Tel: +44 (0) 870 24 0 2171  
Français Tel: +33 (0) 1 41 91 8790

**National Semiconductor Asia Pacific Customer Response Group**

Tel: 65-2544466  
Fax: 65-2504466  
Email: ap.support@nsc.com

**National Semiconductor Japan Ltd.**

Tel: 81-3-5639-7560  
Fax: 81-3-5639-7507