



ON Semiconductor®

<http://onsemi.com>

# LC709201F

CMOS IC

## Battery Monitor IC

### Overview

The LC709201F is an IC that measures the remaining power level of 1-cell lithium-ion secondary batteries by monitoring the battery voltage without an external sense resistor, and detects the remaining battery power level by current prediction. It monitors the battery voltage and realizes a function that precisely measures the remaining battery charge. In addition, the IC realizes the function for calculating the remaining battery power level even more accurately by utilizing a temperature correction function that makes use of the temperature input from a thermistor.

### Features

- Accuracy of remaining battery power level measurement
  - Accuracy of  $\pm 5\%$  during discharging from 100% to 0% (at an ambient operating temperature of 0°C to 50°C)
- Measurement of remaining battery power level
  - The remaining power level is measured four times a second and calculated with each measurement undertaken.
- Interface
  - I<sup>2</sup>Cbus, communication in slave mode up to 100kHz supported
- Ports
 

• I <sup>2</sup> C-bus communication pin	2 (SDA, SCL)
• Battery temperature reading control pin	1 (TSW)
• Analog voltage input pin for battery temperature	1 (TSENSE)
• Reset pin	1 (RESB)
• TEST pin	1 (TEST)
• Power supply pin	2 (VSS, VDD)
- Package form
  - MFP10S (225 mil): LC709201FM-01/02/03
  - VCT16 (2.6×2.6): LC709201FRD-01/02/03

# LC709201F

## Applications

- Cell phones, PDA devices, MP3 players, cordless phones, digital cameras, USB-related devices, etc.

(Note) Depending on the kinds of battery, applicable model differs (LC709201F-01/02/03).

Please contact us for more detail information.

## Package Dimensions

unit : mm (typ)

3086B

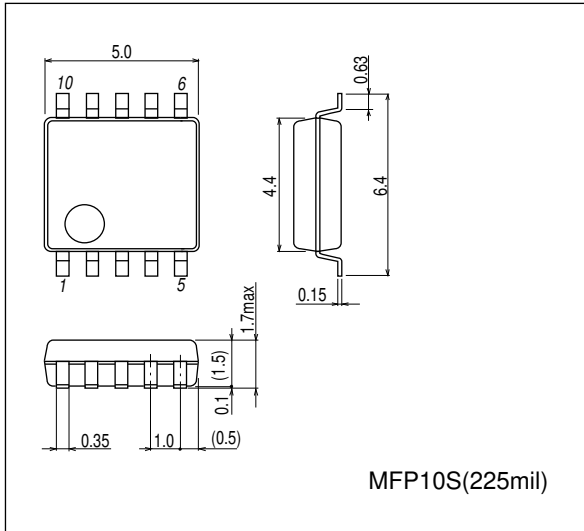

## Package Dimensions

unit : mm (typ)

3318

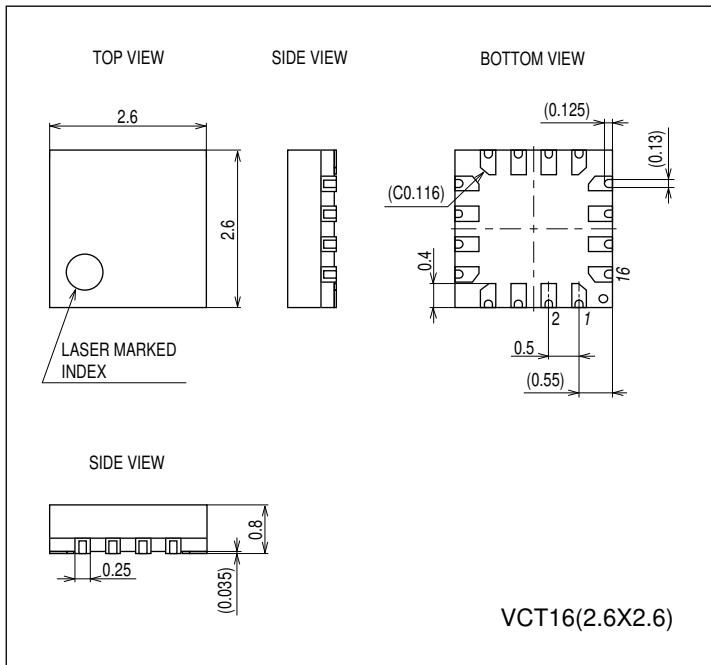

# LC709201F

## Pin Assignment

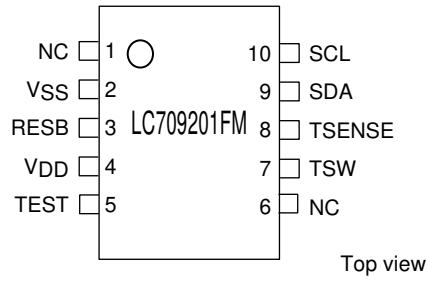

MFP10S (225mil) "Lead-free Type"

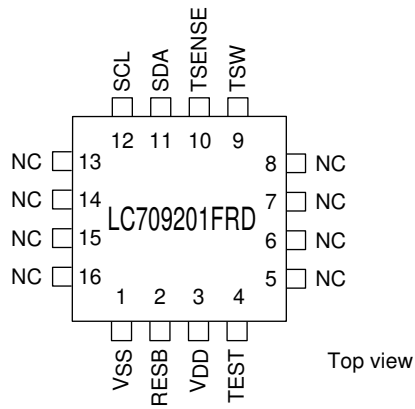

VCT16 (2.6x2.6) "Lead-free Type"

Block Diagram

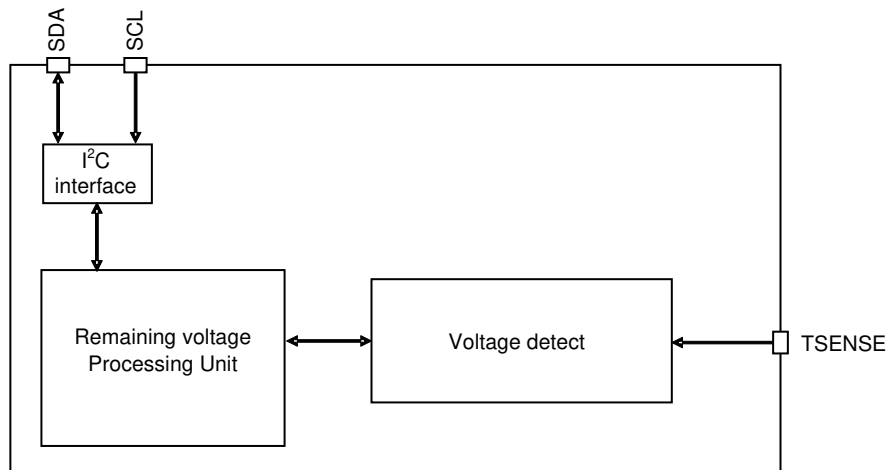

Pin Function

Pin Name	I/O	Description
V <sub>SS</sub>	-	- power pin
V <sub>DD</sub>	-	+ power pin
RESB	I	Reset pin
TEST	I/O	Test pin *Connect an external 100kΩ pull-down resistor.
SDA	I/O	I <sup>2</sup> C data pin
SCL	I/O	I <sup>2</sup> C clock pin
TSW	O	Battery temperature reading control pin *Set high when reading in the temperature, held low at other times.
TSENSE	I	Battery temperature analog voltage input pin

# LC709201F

## Absolute Maximum Ratings at Ta=25°C, VSS=0V

Parameter	Symbol	Pin/Remarks	Conditions	Specification			Unit	
				V <sub>DD</sub> [V]	min	typ		max
Maximum supply voltage	V <sub>DD</sub> max	V <sub>DD</sub>			-0.3		+6.5	V
Input voltage	V <sub>I</sub> (1)	RESB, TSENSE			-0.3		V <sub>DD</sub> +0.3	
Output voltage	V <sub>O</sub> (1)	TSW			-0.3		V <sub>DD</sub> +0.3	
Input/output voltage	V <sub>IO</sub> (1)	SDA, SCL, TEST			-0.3		V <sub>DD</sub> +0.3	
Allowable power dissipation	Pd max	MFP10S	Ta=-40 to +85°C				110	mW
		VCT16					55	
Operating ambient temperature	Topr				-40		+85	°C
Storage ambient temperature	Tstg				-55		-125	

Stresses exceeding Maximum Ratings may damage the device. Maximum Ratings are stress ratings only. Functional operation above the Recommended Operating Conditions is not implied. Extended exposure to stresses above the Recommended Operating Conditions may affect device reliability.

## Allowable Operating Conditions at Ta=-40 to +85°C, VSS=0V

Parameter	Symbol	Pin/Remarks	Conditions	Specification			unit	
				V <sub>DD</sub> [V]	min	typ		max
Operating supply voltage	V <sub>DD</sub> (1)	V <sub>DD</sub>			2.25		5.5	V
High level input voltage	V <sub>IH</sub> (1)	SDA, SCL		2.25 to 5.5	0.3V <sub>DD</sub> +0.7		V <sub>DD</sub>	
Low level input voltage	V <sub>IL</sub> (1)	SDA, SCL		4.0 to 5.5	V <sub>SS</sub>		0.1V <sub>DD</sub> +0.4	
	V <sub>IL</sub> (2)			2.25 to 4.0	V <sub>SS</sub>		0.2V <sub>DD</sub>	

## Electrical Characteristics at Ta=-40 to +85°C, VSS=0V

Parameter	Symbol	Pin/Remarks	Conditions	Specification			Unit	
				V <sub>DD</sub> [V]	min	typ		max
High level input current	I <sub>IH</sub> (1)	RESB, SDA, SCL	V <sub>IN</sub> =V <sub>DD</sub> (including output transistor off leakage current)	2.25 to 5.5			1	μA
Low level input current	I <sub>IL</sub> (1)	RESB, SDA, SCL	V <sub>IN</sub> =V <sub>SS</sub> (including output transistor off leakage current)	2.25 to 5.5	-1			
High level output voltage	V <sub>OH</sub> (1)	TSW	I <sub>OH</sub> =-0.4mA	3.0 to 5.5	V <sub>DD</sub> -0.4			V
	V <sub>OH</sub> (2)		I <sub>OH</sub> =-0.2mA	2.25 to 5.5	V <sub>DD</sub> -0.4			
Low level output voltage	V <sub>OL</sub> (1)	TSW, SDA, SCL	I <sub>OL</sub> =3.0mA	3.0 to 5.5			0.4	
	V <sub>OL</sub> (2)		I <sub>OL</sub> =1.3mA	2.25 to 5.5			0.4	
Hysteresis voltage	VHYS	RESB, SDA, SCL		2.25 to 5.5		0.1V <sub>DD</sub>		
Pin capacitance	CP	All pins	Pins other than the pin under test V <sub>IN</sub> =V <sub>SS</sub> f=1 MHz Ta=25°C	2.25 to 5.5		10		pF
Consumption current	I <sub>DD</sub> (1)	V <sub>DD</sub>	When detecting remaining capacity	2.25 to 5.5		8	16	μA
	I <sub>DD</sub> (2)		When not detecting remaining capacity	2.25 to 5.5		5	12	

# LC709201F

## I<sup>2</sup>C Slave Characteristics at Ta=-40 to+85°C, V<sub>SS</sub>=0V

Parameter	Symbol	Pin/Remarks	Conditions	Specification			unit		
				V <sub>DD</sub> [V]	min	typ		max	
Clock frequency	T <sub>SCL</sub>	SCL		2.25 to 5.5			100	kHz	
Bus free time between STOP condition and START condition	T <sub>BUF</sub>	SCL, SDA	See Fig. 1.		4.7				μs
Hold time (repeated) START condition First clock pulse is generated after this interval	T <sub>HD: STA</sub>	SCL, SDA	See Fig. 1.		4.0				μs
Repeated START condition setup time	T <sub>SU: STA</sub>	SCL, SDA	See Fig. 1.		4.7				μs
STOP condition setup time	T <sub>SU: STO</sub>	SCL, SDA	See Fig. 1.		4.0				μs
Data hold time	T <sub>HD: DAT</sub>	SCL, SDA	See Fig. 1.		300				ns
Data setup time	T <sub>SU: DAT</sub>	SCL, SDA	See Fig. 1.		250				ns
Clock low period	T <sub>LOW</sub>	SCL			4.7				μs
Clock high period	T <sub>HIGH</sub>	SCL			4.0				μs
Clock/data fall time	T <sub>F</sub>	SCL, SDA						300	ns
Clock/data rise time	T <sub>R</sub>	SCL, SDA						1000	ns

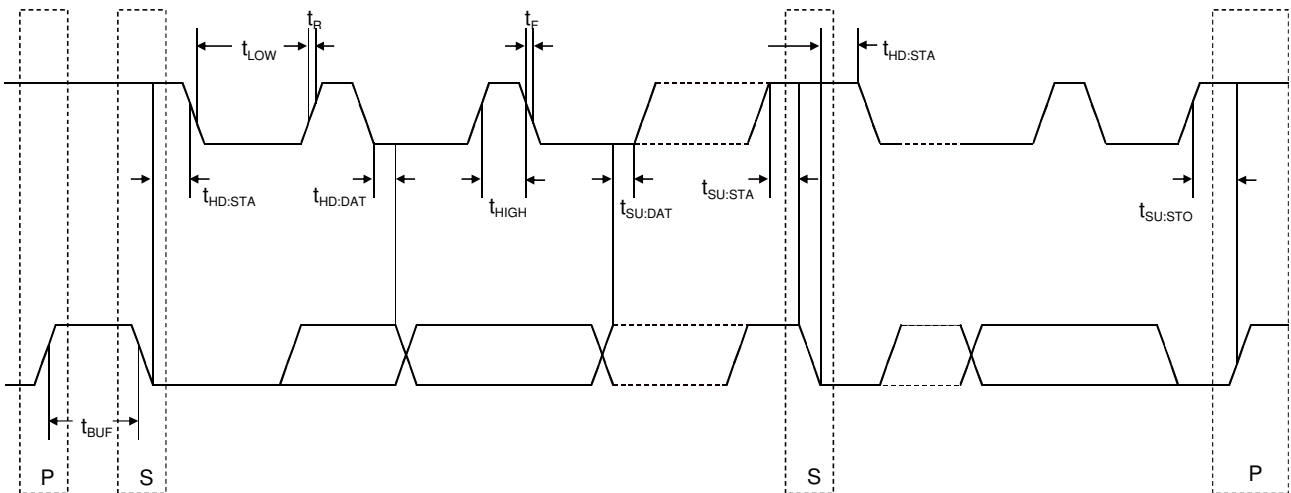

Discharge Characteristics

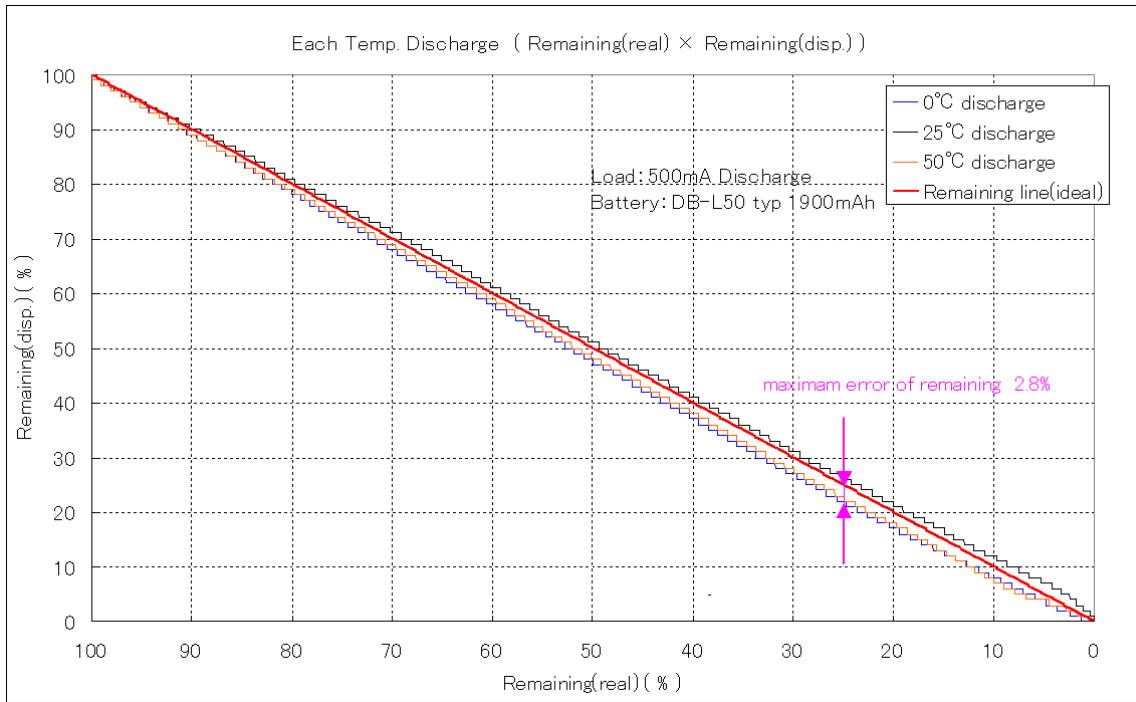

Figure2 Discharge Characteristics by Temperature Change

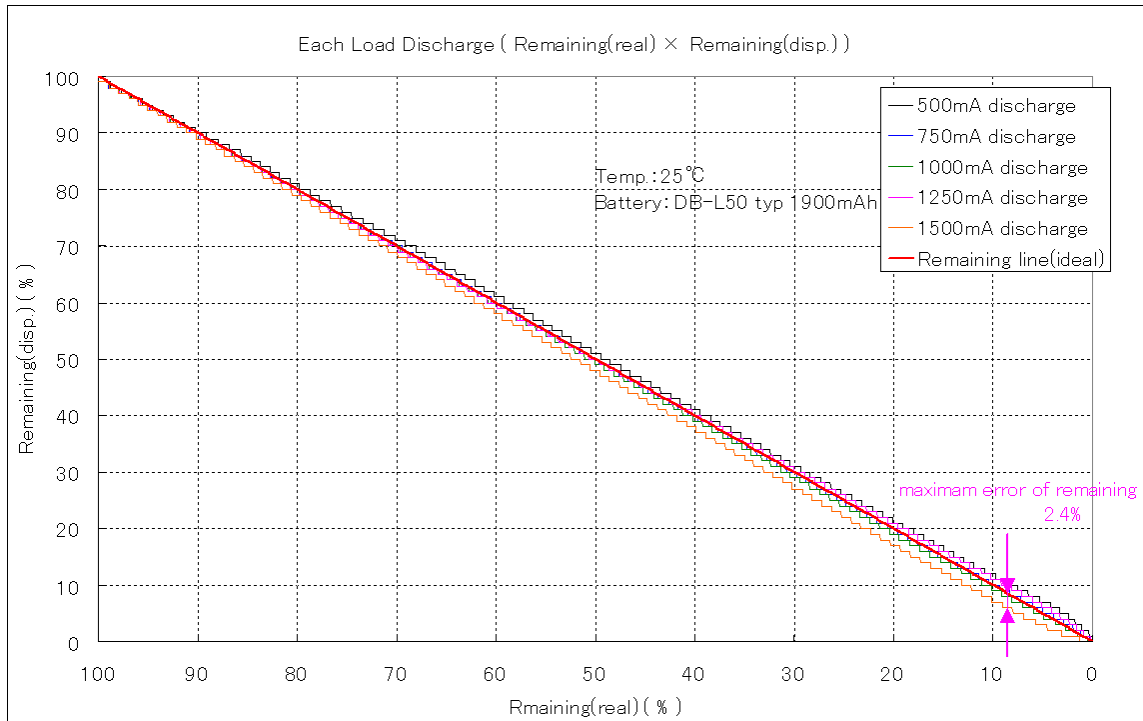

Figure 3 Discharge Characteristics by Load Change

**Communication Protocol**

Communication protocol type: I<sup>2</sup>C  
 Frequency: 100kHz  
 Address: 0x16

**Bus Protocols**

- S : Start Condition
- Sr : Repeated Start Condition
- Rd : Read (bit value of 1)
- Wr : Write (bit value of 0)
- A : ACK (bit value of 0)
- N : NACK (bit value of 1)
- P : Stop Condition
- CRC-8 : Slave Address to Last Data (ex.3778mV: 0x16, 0x09, 0x17, 0xC2, 0x0E → 0x86)
- |  |
|--|
|  |
|--|

 : Master-to-Slave
- |  |
|--|
|  |
|--|

 : Slave-to-Master
- ... : Continuation of protocol

**Read Word Protocol**

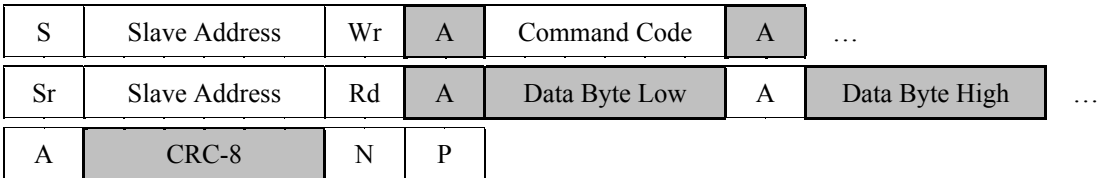

**Write Word Protocol**

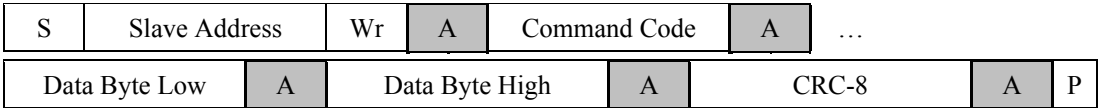

Slave Functions	Command Code	Range	Access	Unit
Cell Temperature	0x08	0 to 65535	R	0.1°K
Cell Voltage	0x09	0 to 65535	R	mV
Current	0x0A	-32768 to 32767	R	mA
Adjustment Pack	0x0B	0 to 255	R	Value
Relative State Of Charge	0x0D	0 to 100	R	%
Remaining Capacity	0x0F	0 to 65535	R	mAh
Full Charge Capacity	0x10	0 to 65535	R	mAh
IC Version	0x11	0 to 65535	R	Version
Adjustment Thermistor	0x12	0 to 255	R	Value
Set Relative State Of Charge	0x08	0xA500 + 0 to 100	W	0xA500 + %
Adjustment Pack	0x08	0x5A00 + 0 to 255	W	0x5A00 + Value
Adjustment Thermistor	0x08	0xAA00 + 0 to 255	W	0xAA00 + Value
Initial Relative State Of Charge	0x09	0xAA55	W	-



# LC709201F

## Application Circuit Example

Figure 4 Example of an application schematic using LC709201F

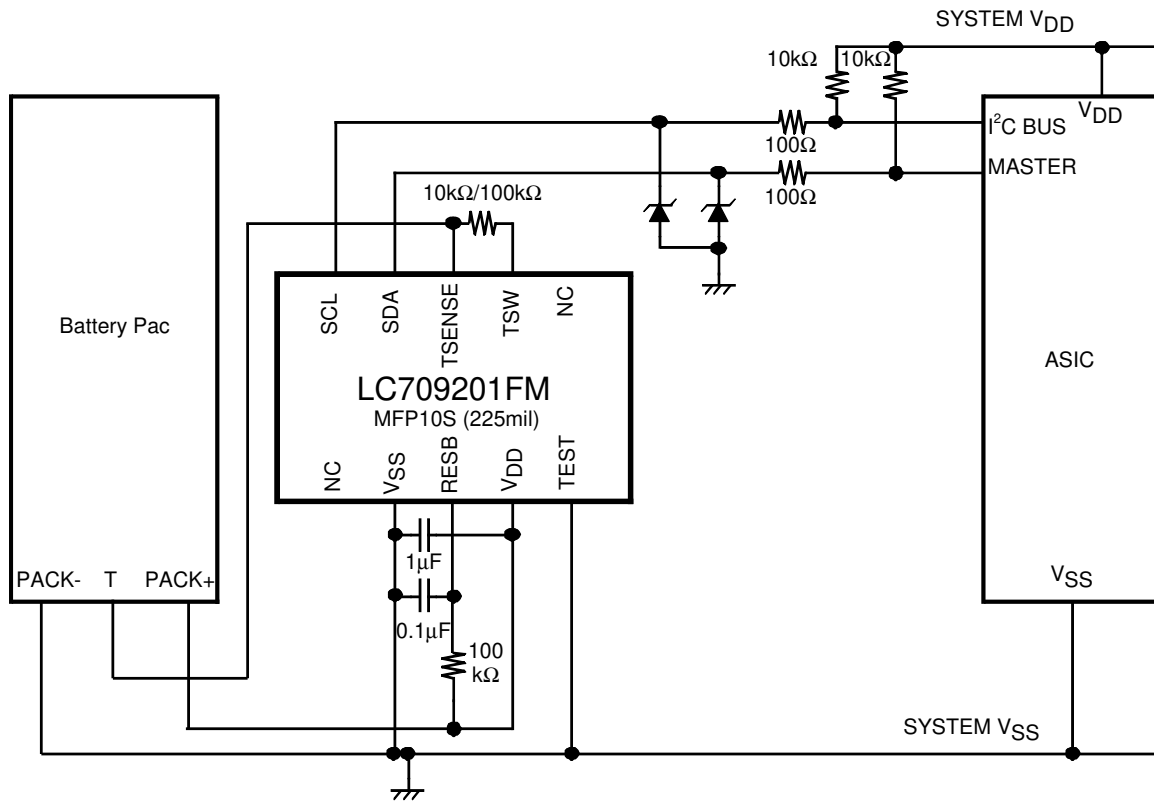
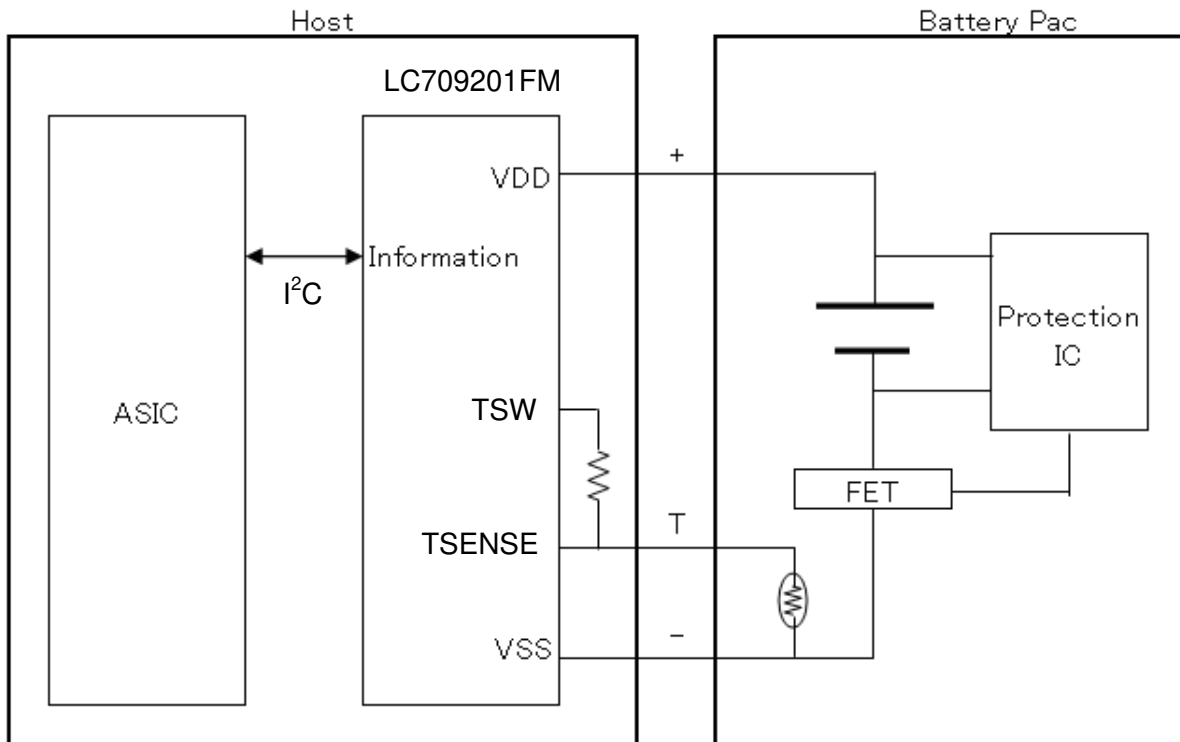

Figure 5 Conceptual diagram using LC709201F



ON Semiconductor and the ON logo are registered trademarks of Semiconductor Components Industries, LLC (SCILLC). SCILLC owns the rights to a number of patents, trademarks, copyrights, trade secrets, and other intellectual property. A listing of SCILLC's product/patent coverage may be accessed at [www.onsemi.com/site/pdf/Patent-Marking.pdf](http://www.onsemi.com/site/pdf/Patent-Marking.pdf). SCILLC reserves the right to make changes without further notice to any products herein. SCILLC makes no warranty, representation or guarantee regarding the suitability of its products for any particular purpose, nor does SCILLC assume any liability arising out of the application or use of any product or circuit, and specifically disclaims any and all liability, including without limitation special, consequential or incidental damages. "Typical" parameters which may be provided in SCILLC data sheets and/or specifications can and do vary in different applications and actual performance may vary over time. All operating parameters, including "Typicals" must be validated for each customer application by customer's technical experts. SCILLC does not convey any license under its patent rights nor the rights of others. SCILLC products are not designed, intended, or authorized for use as components in systems intended for surgical implant into the body, or other applications intended to support or sustain life, or for any other application in which the failure of the SCILLC product could create a situation where personal injury or death may occur. Should Buyer purchase or use SCILLC products for any such unintended or unauthorized application, Buyer shall indemnify and hold SCILLC and its officers, employees, subsidiaries, affiliates, and distributors harmless against all claims, costs, damages, and expenses, and reasonable attorney fees arising out of, directly or indirectly, any claim of personal injury or death associated with such unintended or unauthorized use, even if such claim alleges that SCILLC was negligent regarding the design or manufacture of the part. SCILLC is an Equal Opportunity/Affirmative Action Employer. This literature is subject to all applicable copyright laws and is not for resale in any manner.