

RECOMMENDED P.C.B. PATTERN LAYOUT
GENERAL TOLERANCE: ±0.05

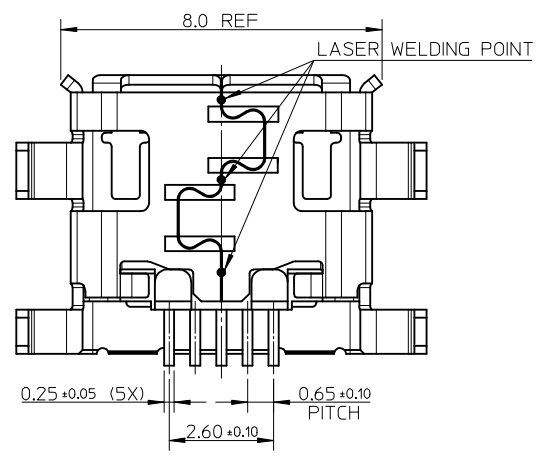
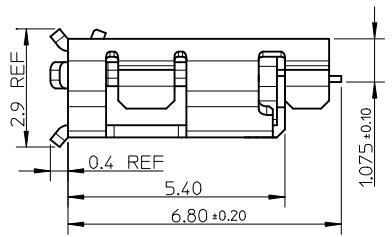
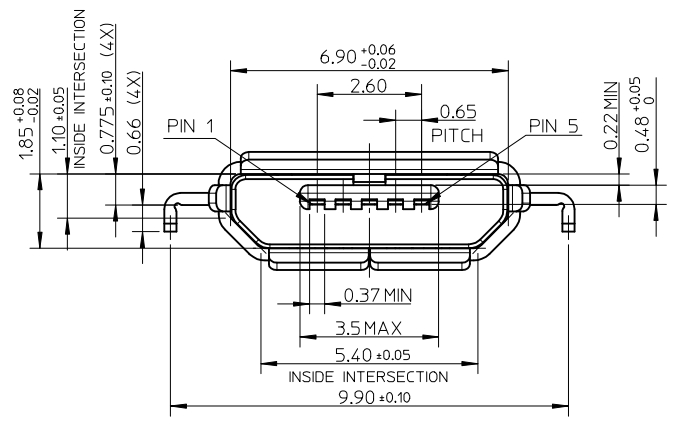

NOTES:

- MATERIAL:
 - HOUSING: LCP, BLACK, UL94V-0
 - TERMINAL: COPPER ALLOY, THICKNESS: 0.15mm
 - SHELL: STAINLESS STEEL, THICKNESS: 0.30mm
- PLATING:
 - TERMINAL:
 - CONTACT AREA: GOLD FLASH OVER 0.75 MICRON MINIMUM Pd/Ni.
 - SOLDER TAIL AREA: GOLD FLASH.
 - UNDER PLATING: NICKEL 2.0 MICRON MINIMUM.
 - SHELL:
 - MATTE TIN 2.0 MICRON MINIMUM.
 - UNDER PLATING: NICKEL 1.27 MICRON MINIMUM.
- TAIL & NAIL COPLANARITY 0.08mm MAXIMUM.
- PRODUCT SPECIFICATION: PS-47642-001.
- PACKAGE SPECIFICATION: PK-47642-001.
- PRODUCT COMPLIANT TO RoHS DIRECTIVE 2002/95/EC AND ELV 2000/53/EC.

REVISED EC NO: SH2013-0086 DRWN:XOZHANG 2012/09/24 CHKD:XOZHANG 2012/09/24 APPR:AYIN 2012/10/11	QUALITY SYMBOLS ▽=0 ▽=0 ▽=0	GENERAL TOLERANCES (UNLESS SPECIFIED)		DIMENSION STYLE MM ONLY		SCALE 8:1	DESIGN UNITS METRIC	THIRD ANGLE PROJECTION		
			mm	INCH	DRAWN BY XJSONG	DATE 2011/09/22	TITLE MICRO USB B RECEPTACLE MIDDLE MOUNT			
		4 PLACES	± ---	± ---	CHECKED BY XJSONG	DATE 2011/09/22				
		3 PLACES	± ---	± ---	APPROVED BY AYIN	DATE 2012/04/10				
			ANGULAR ± 3 °		MATERIAL NO. 105193-0001	DOCUMENT NO. SD-105193-001	SHEET NO. 1 OF 2			
		DRAFT WHERE APPLICABLE MUST REMAIN WITHIN DIMENSIONS								
		THIS DRAWING CONTAINS INFORMATION THAT IS PROPRIETARY TO MOLEX INCORPORATED AND SHOULD NOT BE USED WITHOUT WRITTEN PERMISSION								

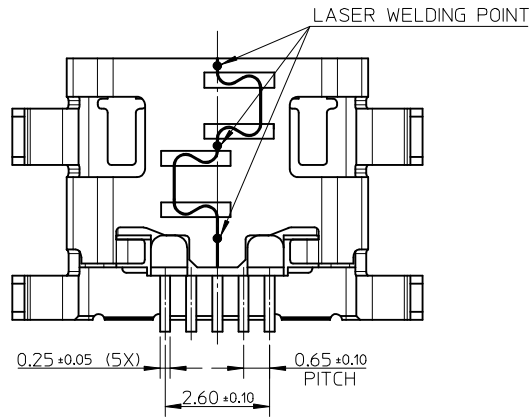
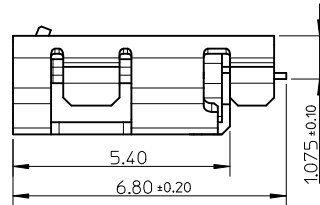
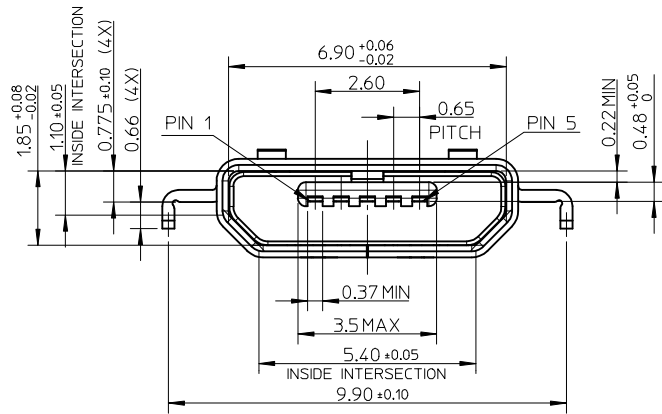
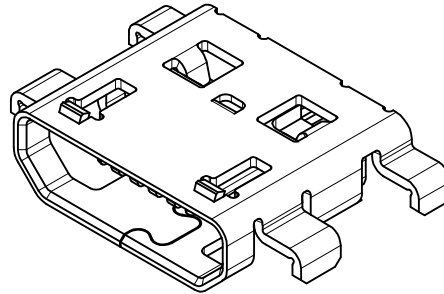
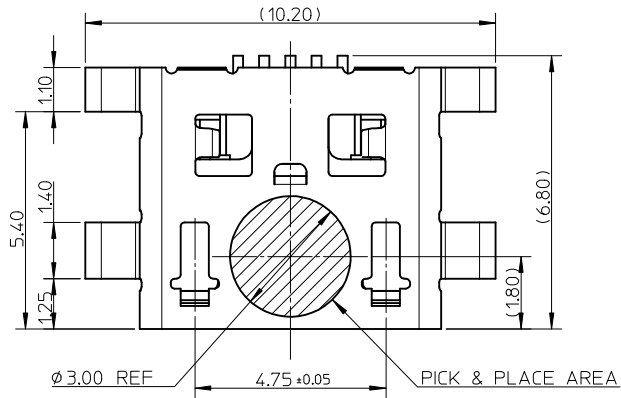

SEE SHEET 1 EC NO: SH2013-0086 DRWN:XOZHANG 2012/09/24 CHKD:XOZHANG 2012/09/24 APPR:AYIN 2012/10/11	QUALITY SYMBOLS ▽=0 ▽=0 ▽=0	GENERAL TOLERANCES (UNLESS SPECIFIED)		DIMENSION STYLE MM ONLY	SCALE 8:1	DESIGN UNITS METRIC	THIRD ANGLE PROJECTION	
			mm	INCH	DRAWN BY XJSONG	DATE 2011/09/22	TITLE MICRO USB B RECEPTACLE MIDDLE MOUNT FLANGELESS TYPE	
		4 PLACES	± ---	± ---	CHECKED BY XJSONG	DATE 2011/09/22	molex	
		3 PLACES	± ---	± ---	APPROVED BY AYIN	DATE 2012/04/10		
			ANGULAR ± 3°		MATERIAL NO. 105193-1001	DOCUMENT NO. SD-105193-001	SHEET NO. 2 OF 2	
		DRAFT WHERE APPLICABLE MUST REMAIN WITHIN DIMENSIONS		SIZE A3	THIS DRAWING CONTAINS INFORMATION THAT IS PROPRIETARY TO MOLEX INCORPORATED AND SHOULD NOT BE USED WITHOUT WRITTEN PERMISSION			