

TOSHIBA CCD Image Sensor CCD (charge coupled device)

# TCD1103GFG

The **TCD1103GFG** is a high sensitive and low dark current 1500-elements linear image sensor.

This device consists of sensitivity CCD chip.

The TCD1103GFG has electronic shutter function (ICG).

Electronic shutter function can keep always output voltage constant that vary with intensity of lights.

## Features

- Number of Image Sensing Elements: 1500 elements
- Image Sensing Element Size: 5.5  $\mu\text{m}$   $\times$  64  $\mu\text{m}$
- Photo Sensing Region: High sensitive and low dark current pn photodiode
- Internal Circuit: CCD Drive Circuit
- Power Supply: Only 3.0V Drive (MIN.)
- Function: Electronics Shutter, Sample and Hold Circuit
- Package: 16 pin GLCC Package

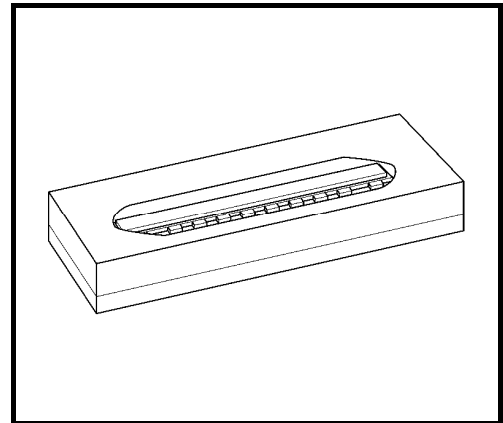

Weight: 0.37 g (typ.)

## Maximum Ratings (Note1)

Characteristic	Symbol	Rating	Unit
Master clock pulse voltage	$V_{\phi M}$	-0.3~7.0	V
Shift pulse voltage	$V_{SH}$		
ICG pulse voltage	$V_{ICG}$		
Digital power supply	$V_{DD}$		
Analog Power Supply	$V_{AD}$		
Operating temperature	$T_{opr}$	-25~60	$^{\circ}\text{C}$
Storage temperature	$T_{stg}$	-40~85	$^{\circ}\text{C}$

Note 1: All voltage are with respect to SS terminals (ground).

## Pin Connections

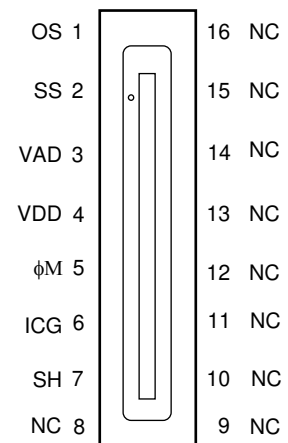

**Block Diagram**

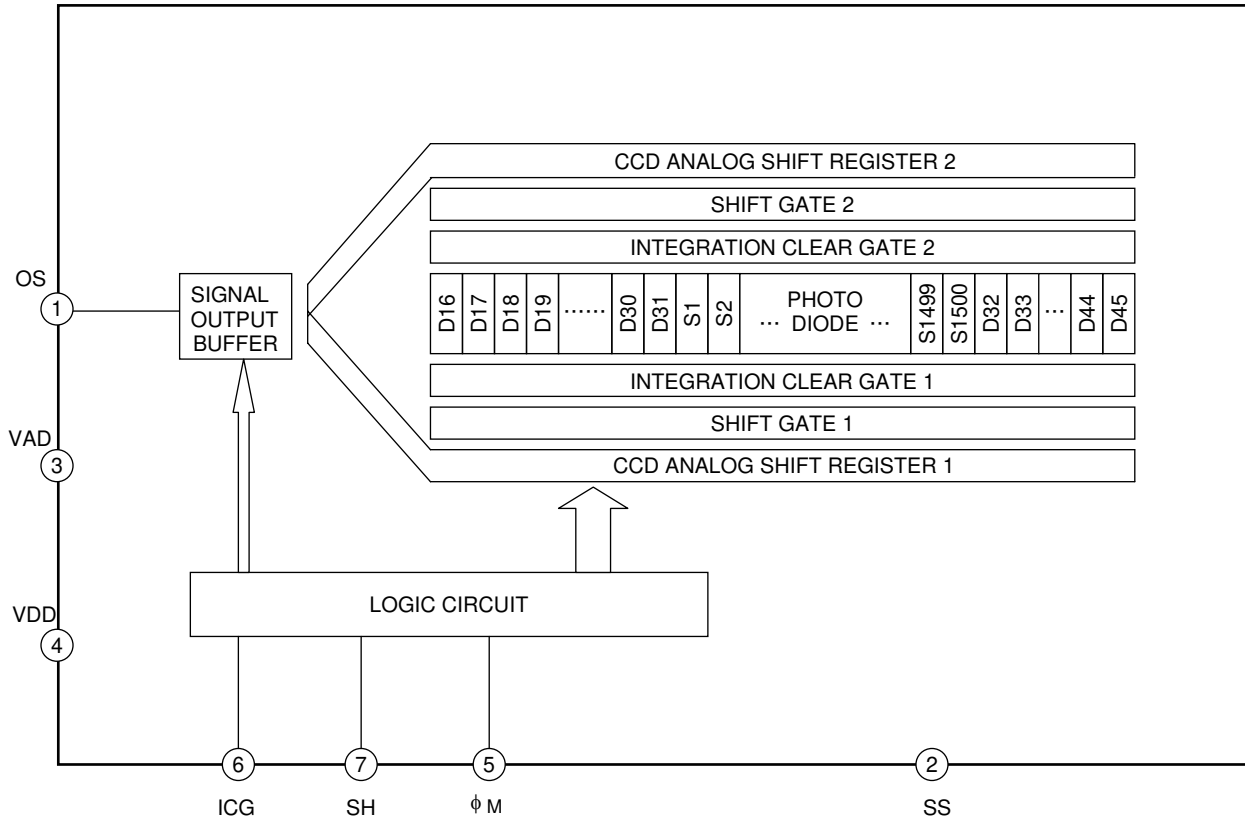

**Pin Names**

Pin No.	Symbol	Name	Pin No.	Symbol	Name
1	OS	Output signal	16	NC	Non Connection
2	SS	Ground	15	NC	Non Connection
3	VAD	Power (Analog)	14	NC	Non Connection
4	VDD	Power (Digital)	13	NC	Non Connection
5	φM	Master clock	12	NC	Non Connection
6	ICG	Integration clear gate	11	NC	Non Connection
7	SH	Shift gate	10	NC	Non Connection
8	NC	Non Connection	9	NC	Non Connection

## Optical/Electrical Characteristics

(Ta = 25°C, V<sub>φ</sub> = 3.3V (pulse), f<sub>φ</sub> = 2.0 MHz (Data rate=1MHz), Tint(Integration time) =10ms, Load resistance = 100 kΩ, VAD = VDD = 3.3V, Light source = Daylight fluorescent lamp)

Characteristics	Symbol	Min	Typ.	Max	Unit	Note
Sensitivity	R	55	79	—	V/lx·s	(Note2)
Photo response non uniformity	PRNU	—	—	10	%	(Note3)
Register imbalance	RI	—	—	3	%	(Note4)
Saturation output voltage	V <sub>SAT</sub>	450	900	—	mV	(Note5)
Saturation exposure	SE	—	0.008	—	lx·s	(Note6)
Dark signal voltage	V <sub>MDK</sub>	—	3	15	mV	(Note7)
DC power dissipation	PD	—	16	48	mW	
Total transfer efficiency	TTE	92	95	—	%	
Output impedance	Z <sub>O</sub>	—	0.5	1.0	kΩ	
DC output voltage	V <sub>OS</sub>	1.0	1.5	2.0	V	(Note8)
Dynamic range	DR	—	200	—	—	(Note9)

Note 2: Sensitivity is defined for signal outputs when the photosensitive surface is applied with the light of uniform illumination and uniform color temperature.

Note 3: PRNU is defined for a single chip by the expressions below when the photosensitive surface is applied with the light of uniform illumination and uniform color temperature.

$$PRNU = \frac{\Delta X}{\bar{X}} \times 100(\%)$$

Where  $\bar{X}$  is average of total signal output and  $\Delta X$  is the maximum deviation from  $\bar{X}$ . The amount of incident light is 1/2·SE.

Note 4: Register imbalance is defined as follows.

$$RI = \frac{\Delta Y - \Delta Z}{\bar{X}} \times 100(\%)$$

Where  $\bar{X}$  is average of total signal output.

$\Delta Y$  : | average of odd signal output – average of even signal output |

$\Delta Z$  : | average of odd dummy signal – average of even dummy signal |

Note 5: V<sub>SAT</sub> is defined as minimum saturation output of all effective pixels.

Note 6: Definition of SE

$$SE = \frac{V_{SAT}}{R} \text{ (lx·s)}$$

Note 7: V<sub>MDK</sub> is defined as maximum dark signal voltage of all effective pixels.

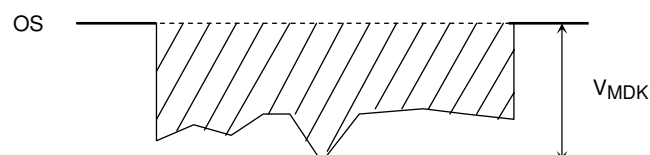

Note 8: DC signal output voltage is defined as follows.

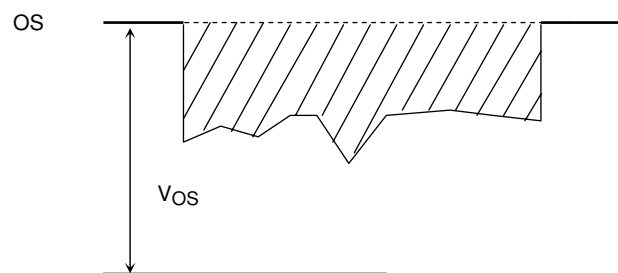

Note 9: Definition of DR

$$DR = \frac{V_{SAT}}{V_{MDK}}$$

VMDK is proportional to Tint (Integration time), so, the shorter Tint condition makes wider DR.

## Operating Condition

Characteristics		Symbol	Min	Typ.	Max	Unit	
Master clock pulse voltage	"H" Level	$V_{\phi M}$	3.0	3.3	4.0	V	(Note 10)
	"L" Level		0	0	0.44		
Shift pulse voltage	"H" Level	$V_{SH}$	3.0	3.3	4.0	V	(Note 10)
	"L" Level		0	0	0.44		
ICG pulse voltage	"H" Level	$V_{ICG}$	3.0	3.3	4.0	V	(Note 10)
	"L" Level		0	0	0.44		
Power supply voltage (Digital)		$V_{DD}$	3.0	3.3	4.0	V	(Note 11)
Power supply voltage (Analog)		$V_{AD}$	3.0	3.3	4.0	V	(Note 11)

Note 10: "H" level of maximum pulse voltage =  $V_{DD} \geq V_{DD} - 0.5V$  = "H" level of minimum pulse voltage.

Note 11:  $V_{AD} = V_{DD}$

## Clock Characteristics ( $T_a = 25^\circ C$ ) ( $3.0V \leq V_{AD} = V_{DD} \leq 4.0V$ )

Characteristics	Symbol	Min	Typ.	Max	Unit
Master clock frequency	$f_{\phi M}$	0.4	2	4	MHz
Data Rate	$f_{DATA}$	0.2	1	2	MHz
Master clock capacitance	$C_{\phi M}$	—	10	—	pF
ICG Pulse capacitance	$C_{ICG}$	—	35	—	pF
Shift pulse capacitance	$C_{SH}$	—	150	—	pF

Optical/Electrical characteristics of page 3 are defined under the condition of 1MHz data rate.

**Timing Chart 1**

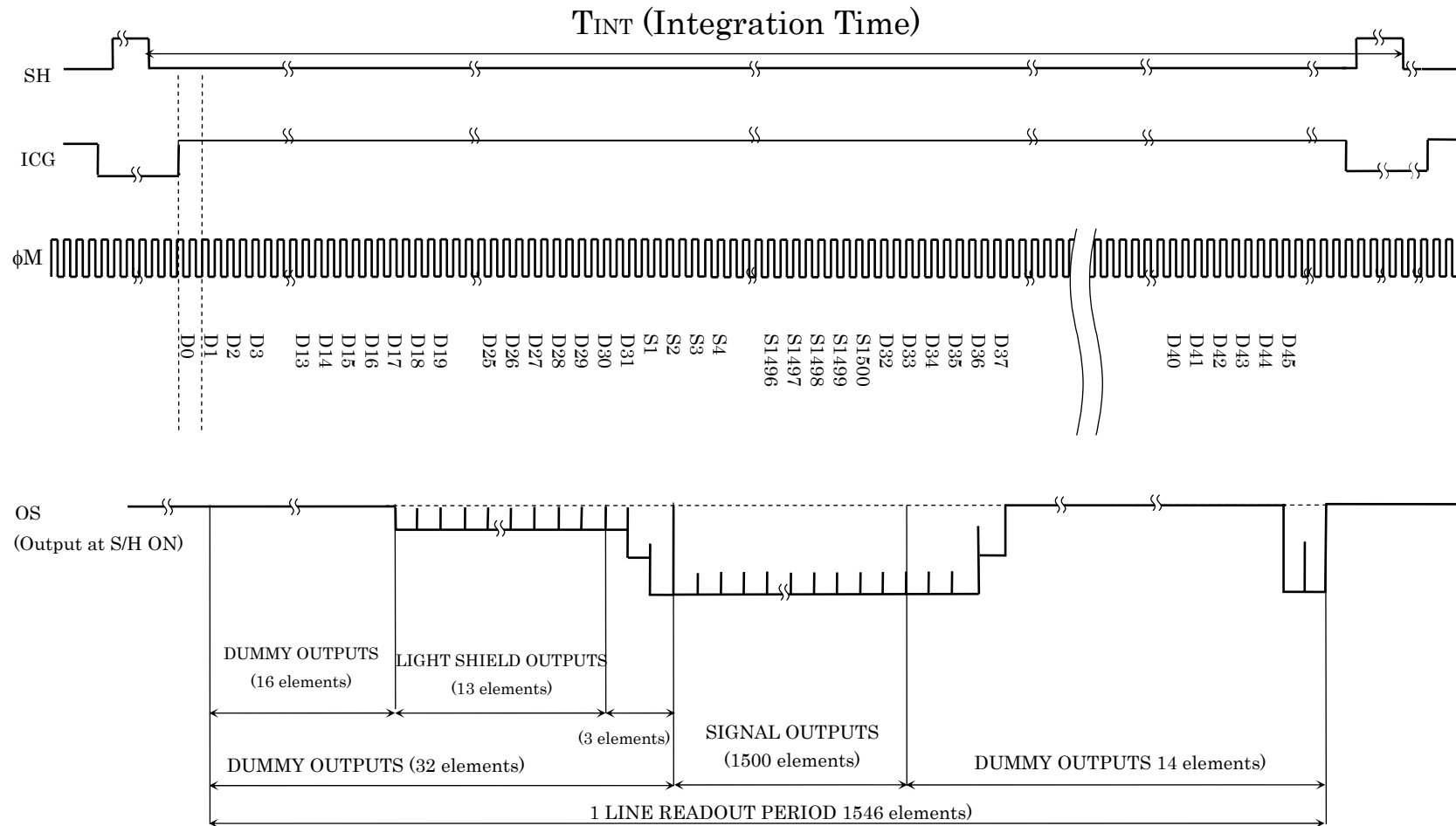

**Timing Chart 2 (Use electric shutter function)**

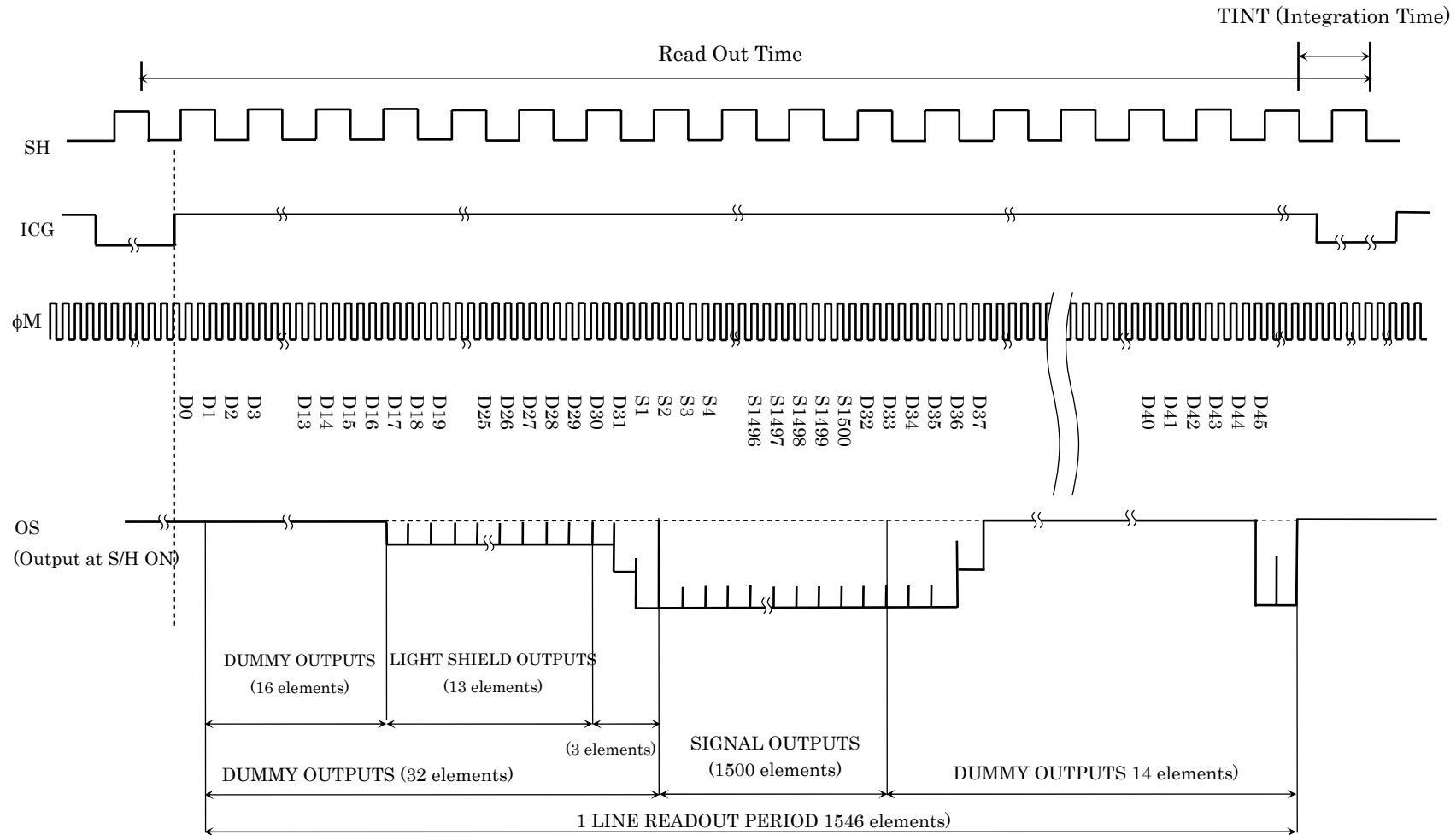

**Timing Requirements**

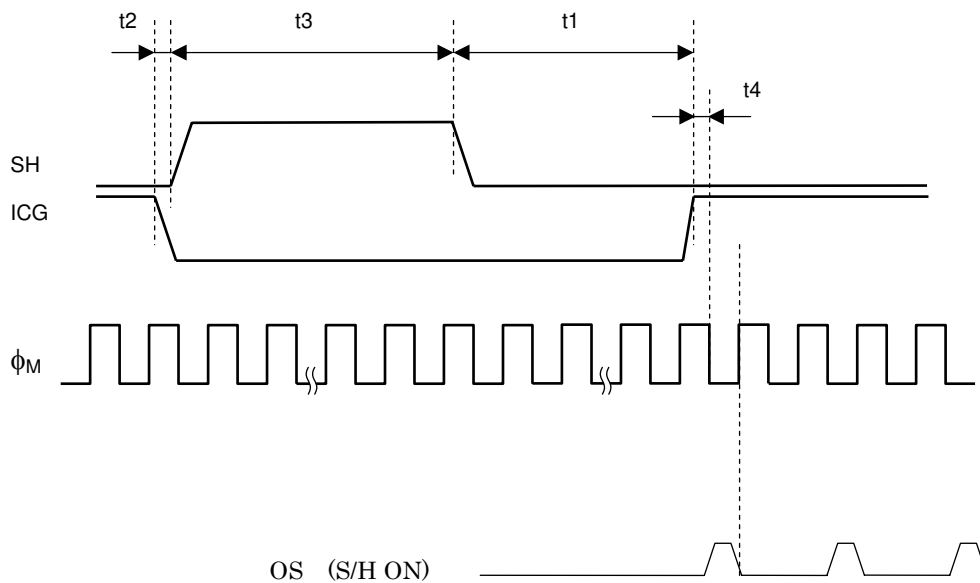

Characteristics	Symbol	Min	Typ.	Max	Unit
ICG pulse delay	$t_1$	1000	5000	—	ns
Pulse timing of ICG and SH	$t_2$	100	500	1000	ns
Shift pulse width	$t_3$	1000	—	—	ns
Pulse timing of ICG and $\phi_M$	$t_4$	0	20	*	ns

\* : To keep  $\phi_M$  “High” level when ICG switch from “Low” to “High” level.

**Use electronic shutter**

Pulse timing of SH and ICG

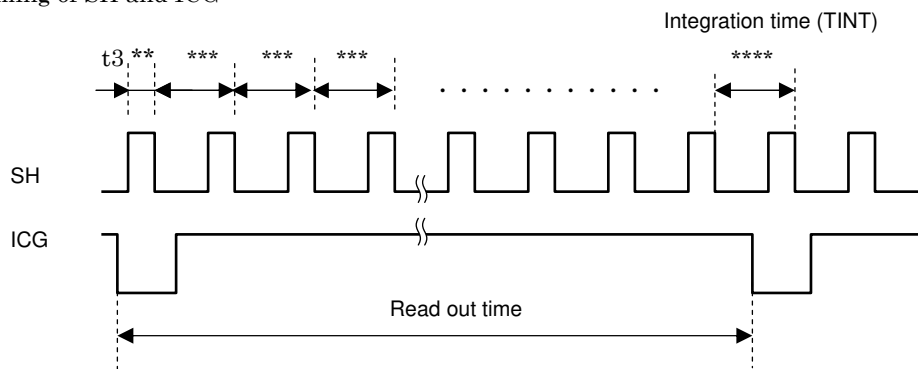

\*\* : Each SH high pulse have to keep always the same value with “  $t_3$  “. ( $t_3 \geq 1000\text{ns}$  (Min.))

\*\*\* : SH pulse cycle have to keep the same cycle (SH cycle period  $\geq 10 \mu\text{s}$ ) except TINT period.

\*\*\*\* : TINT  $\geq 10 \mu\text{s}$  (Min.)

Note : The illumination of light source must be used with less that 1000 times based on 10ms TINT.



Typical performance curves

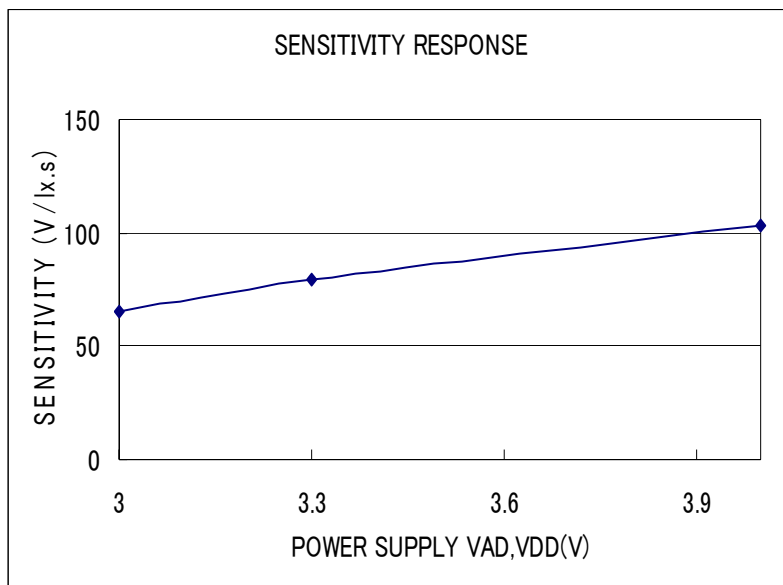
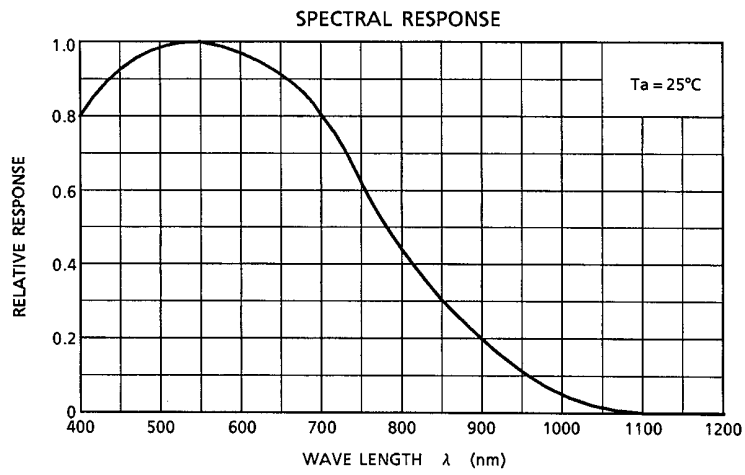

Typical performance curves

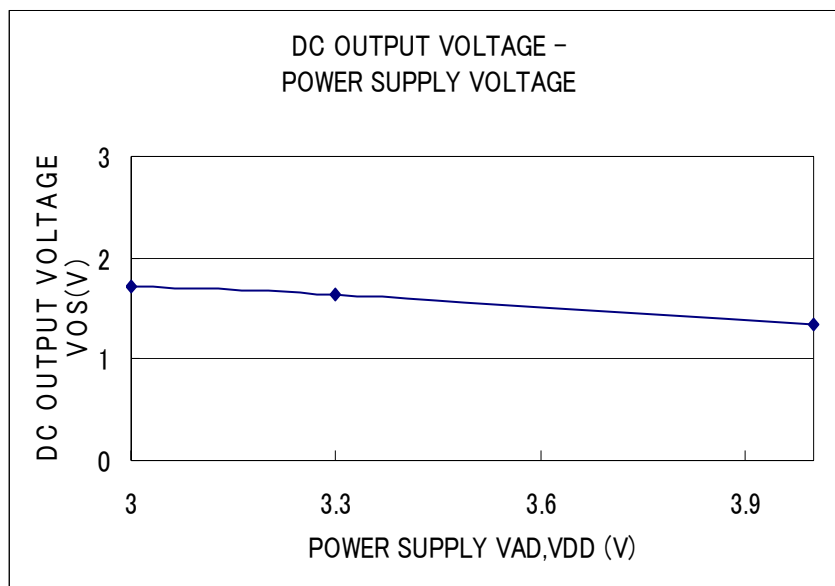

**Typical Drive Circuit**

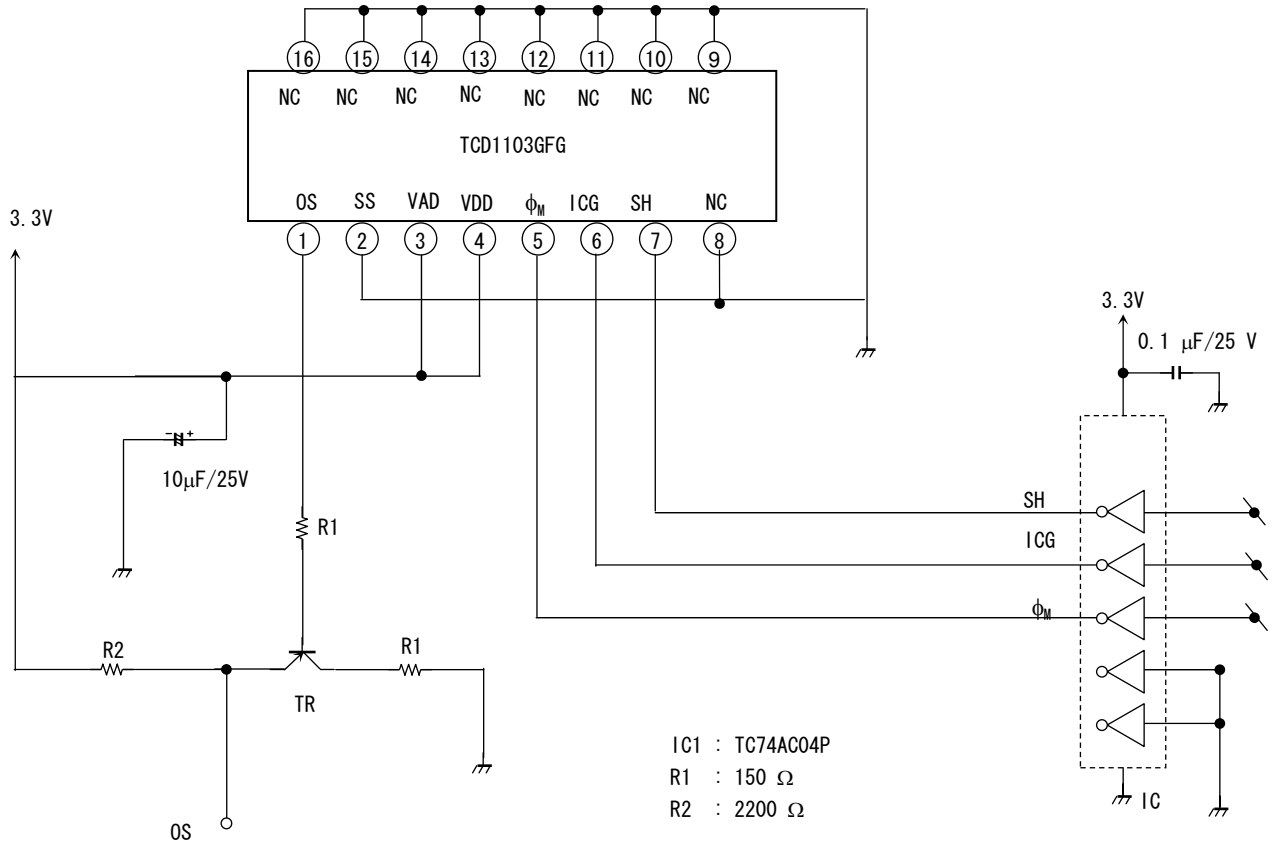

**Caution****1. Electrostatic Breakdown**

Store in shorting clip or in conductive foam to avoid electrostatic breakdown.

CCD Image Sensor is protected against static electricity, but inferior puncture mode device due to static electricity is sometimes detected. In handling the device, it is necessary to execute the following static electricity preventive measures, in order to prevent the trouble rate increase of the manufacturing system due to static electricity.

- a. Prevent the generation of static electricity due to friction by making the work with bare hands or by putting on cotton gloves and non-charging working clothes.
- b. Discharge the static electricity by providing earth plate or earth wire on the floor, door or stand of the work room.
- c. Ground the tools such as soldering iron, cutting pliers, tweezers or pincer.

It is not necessarily required to execute all precaution items for static electricity.

It is all right to mitigate the precautions by confirming that the trouble rate within the prescribed range.

- d. When the product is handed, please use tweezers to avoid the damage of CCD image sensor. Recommended tweezers is P-815 (HOZAN) or equivalent.
- e. Ionized air is recommended for discharge when handling CCD image sensors.

**2. Incident Light**

CCD sensor is sensitive to infrared light. Note that infrared light component degrades resolution and PRNU of CCD sensor.

**3. Ultrasonic Cleaning**

Ultrasonic cleaning should not be used with such hermetically-sealed ceramic package as CCD because the bonding wires can become disconnected due to resonance during the cleaning process.

**4. Window Glass Protective Tape**

The window glass protective tape is manufactured from materials in which static charges tend to build up. When removing the tape from CCD sensor after solder mounting, install an ionizer to prevent the tape from being charged with static electricity.

When the tape is removed, adhesives will remain in the glass surface. Since these adhesives appear as black or white flaws on the image, please wipe the window glass surface with the cloth into which the organic solvent was infiltrated. Then please attach CCD to a product.

Do not reuse the tape.

## 5. Cleaning Method of the Window Glass Surface

### Wiping Cloth

- a. Use soft cloth with a fine mesh.
- b. The wiping cloth must not cause dust from itself.
- c. Use a clean wiping cloth necessarily.

Recommended wiping cloth is as follow;

- MK cloth (Toray Industries)

### Cleaner

Recommended cleaning liquid of window glass are as follow;

- EE-3310 (Olympus)

When using solvents, such as alcohol, unavoidably, it is cautious of the next.

- a. A clean thing with quick-drying.
- b. After liquid dries, there needs to be no residual substance.
- c. A thing safe for a human body.

And, please observe the use term of a solvent and use the storage container of a solvent to be clean.

Be cautious of fire enough.

### Way of Cleaning

First, the surface of window glass is wiped with the wiping cloth into which the cleaner was infiltrated.

Please wipe down the surface of window glass at least 2 times or more.

Next, the surface of window glass wipes with the dry wiping cloth. Please wipe down the surface of window glass at least 3 times or more.

Finally, blow cleaning is performed by dry N2 filtered.

If operator wipes the surface of the window glass with the above-mentioned process and dirt still remains, Toshiba recommends repeating the clean operation from the beginning.

Be cautious of the next thing.

- a. Don't infiltrate the cleaner too much.
- b. A wiping portion is performed into the optical range and don't touch the edge of window glass.
- c. Be sure to wipe in a long direction and the same direction.
- d. A wiping cloth always uses an unused portion.

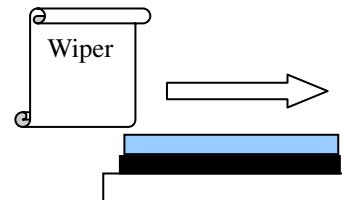

**The standard reflow condition for GLCC (Surface Mount device, Pb-Free)**

**1. Storage precautions**

- 1) Do not drop or toss device packaging. The laminated aluminum material in it can be rendered ineffective by rough handling.
- 2) Ensure packaging materials are stored in a 30°C90%RH environment and do not store at the low temperature to prevent dew condensation. Use devices within 12 months; do not store them longer than that.
- 3) If the 30% humidity indicator is pink when the packaging is opened, bake the devices at 125°C for 24 hours to remove any moisture present. Devices should also be baked, whether still packed or not, if the effective usage period of the indicator has expires.
- 4) Perform destructive prevention of the devices by static electricity in case of implementation of baking processing.
- 5) After opening the moisture-proof packing, store the products in the environment under 30°C, and below 60%RH, and use them within 5 days.  
If the effective usage period passed after opening the moisture-proof packing, baking should be done before use at 125°C for 24 hours.
- 6) CCD surface mount products may have a haze on the inside of glass, so be careful about folling.  
Even if the haze arises inside of glass, when it is not on the pixel eria, there is no problem in quality.

**2. Mounting conditions using reflow**

- 1) Mounting method : (a) Hot air reflows.  
(b) Infrared ray reflow
- 2) Preheating condition : 150~180°C, 60~120 seconds
- 3) Reflow condition : (a) maximum 240°C  
(b) over 230°C, within 30~50 seconds
- 4) Heating times : only 1 time
- 5) Caution : This product does not support a Re-flow with Pb-Sn solder. Pb-free solder should be used to Re-flow with Fig1's profile.

\* The temperature profile is specified in terms of the temperature of top surface of the device. This temperature profile shows maximum guaranteed device temperature. Please set up the optimum temperature profile conditions within the Fig.1 profile.

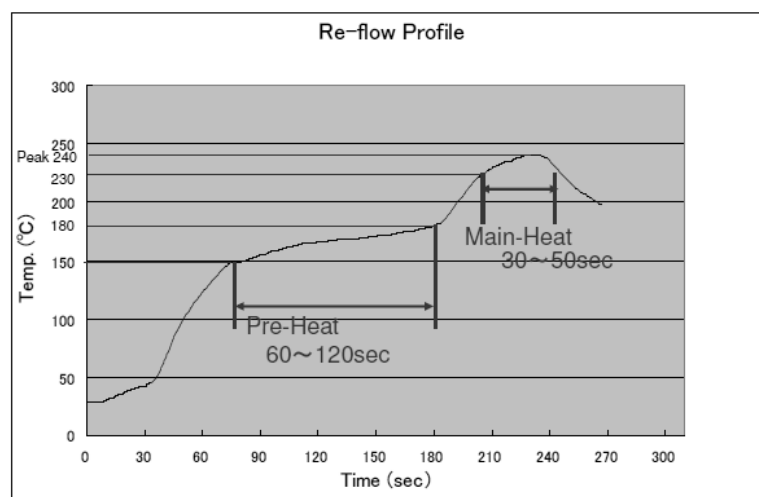

Fig.1 Example of recommended temperature profile for reflows

In addition, in case of the repair work accompanied by IC removal, since the degree of parallel may be spoiled with the left solder, please do not carry out.

### 3. Mounting

- 1) In the case of solder mounting, the devices should be mounted with the window glass protective tape in order to avoid dust or dirt included in reflow machine.
- 2) The window glass protective tape is manufactured from materials in which static charges tend to build up. When removing the tape from CCD sensor after solder mounting, install an ionizer to prevent the tape from being charged with static electricity.
- 3) When the tape is removed, adhesives will remain in the glass surface. Since these adhesives appear as black or white flaws on the image, please wipe the window glass surface with the cloth into which the organic solvent was infiltrated. Then please attach CCD to a product.
- 4) Do not reuse the window glass protective tape.
- 5) The parts of glass seal area have possibility to be became clouded by reflow process, however, there is no problem in quality..

### 4. Foot Pattern on the PCB

We recommend Fig 2's foot pattern for your PCB (Printed circuit Board).

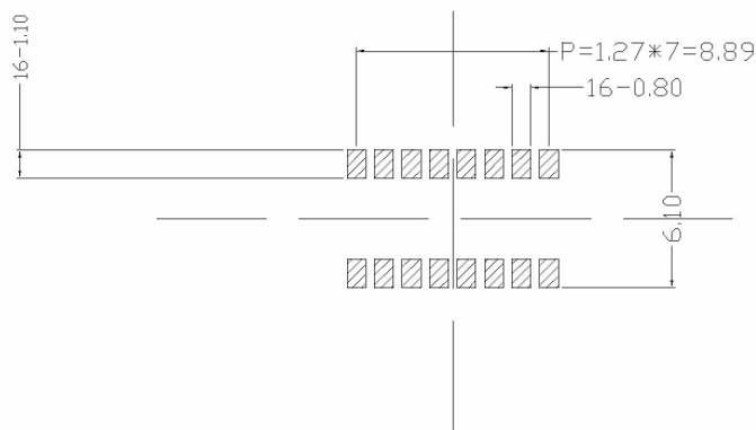

Fig.2

### 5. Mask for Solder Paste Application

We recommend metal mask that have the following thickness.

- a thickness of 0.1mm.

And, we recommend that the size of the pattern of the metal mask is 100% of recommended foot pattern at fig. 2.

**Package Dimensions**

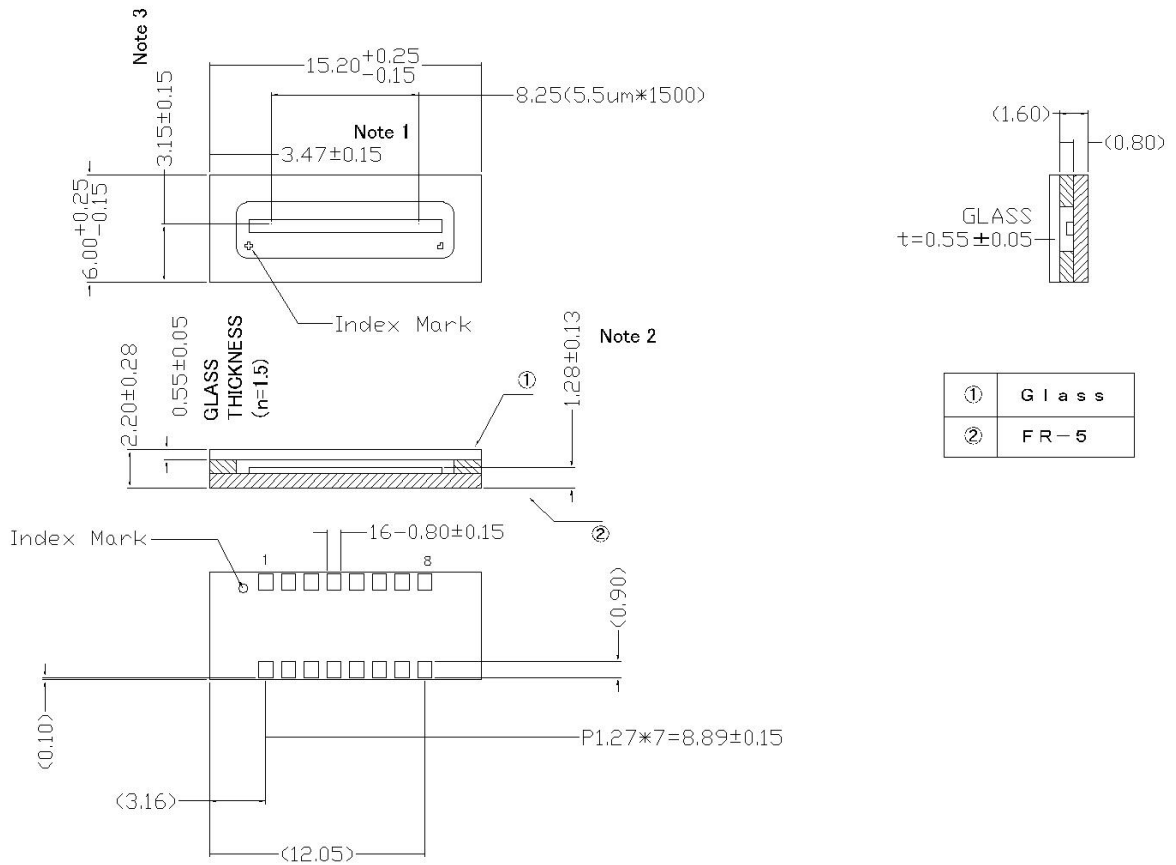

Note 1: Sensor pixel (S1) to edge of package.  
 Note 2: Top of chip to bottom of package.  
 Note 3: Chip center to edge of package.



Revision	Date	Description	Note
1.0	2008-6-23	New	-
2.0	2009-01-15	Added: Caution of storage Deleted: Caution of soft tray	-

- The information contained herein is subject to change without notice. 021023\_D
- TOSHIBA is continually working to improve the quality and reliability of its products. Nevertheless, semiconductor devices in general can malfunction or fail due to their inherent electrical sensitivity and vulnerability to physical stress. It is the responsibility of the buyer, when utilizing TOSHIBA products, to comply with the standards of safety in making a safe design for the entire system, and to avoid situations in which a malfunction or failure of such TOSHIBA products could cause loss of human life, bodily injury or damage to property.  
In developing your designs, please ensure that TOSHIBA products are used within specified operating ranges as set forth in the most recent TOSHIBA products specifications. Also, please keep in mind the precautions and conditions set forth in the "Handling Guide for Semiconductor Devices," or "TOSHIBA Semiconductor Reliability Handbook" etc. 021023\_A
- The TOSHIBA products listed in this document are intended for usage in general electronics applications (computer, personal equipment, office equipment, measuring equipment, industrial robotics, domestic appliances, etc.). These TOSHIBA products are neither intended nor warranted for usage in equipment that requires extraordinarily high quality and/or reliability or a malfunction or failure of which may cause loss of human life or bodily injury ("Unintended Usage"). Unintended Usage include atomic energy control instruments, airplane or spaceship instruments, transportation instruments, traffic signal instruments, combustion control instruments, medical instruments, all types of safety devices, etc. Unintended Usage of TOSHIBA products listed in this document shall be made at the customer's own risk. 021023\_B
- The products described in this document shall not be used or embedded to any downstream products of which manufacture, use and/or sale are prohibited under any applicable laws and regulations. 060106\_Q
- The information contained herein is presented only as a guide for the applications of our products. No responsibility is assumed by TOSHIBA for any infringements of patents or other rights of the third parties which may result from its use. No license is granted by implication or otherwise under any patent or patent rights of TOSHIBA or others. 021023\_C
- Please use this product in compliance with all applicable laws and regulations that regulate the inclusion or use of controlled substances.  
Toshiba assumes no liability for damage or losses occurring as a result of noncompliance with applicable laws and regulations. 060819\_AF
- The products described in this document are subject to foreign exchange and foreign trade control laws. 060925\_E