

PART NAME: KNOB

SCALE: 1:1

DATE: 7/17/12

DR. BY: JAM



DESIGNERS & MANUFACTURERS
OF KNOBS, HANDLENDS, CAPS &
CUSTOM PLASTIC COMPONENTS

P/N 1231-F

THIS DRAWING IS THE PROPERTY OF DAVIES MOLDING COMPANY, IS SUBMITTED SOLELY AS A DESIGN OR ENGINEERING PROJECT.
WE ACCEPT NO RESPONSIBILITY WHATSOEVER FOR THE PRACTICAL APPLICATION OF THE PIECES MADE TO THIS DESIGN.

| | |
|-----------|--------|
| MOLD # | 1231 |
| CAVITY | 1231 |
| CORE | 1231 |
| PIN | 1231-F |
| SET SCREW | I0328 |

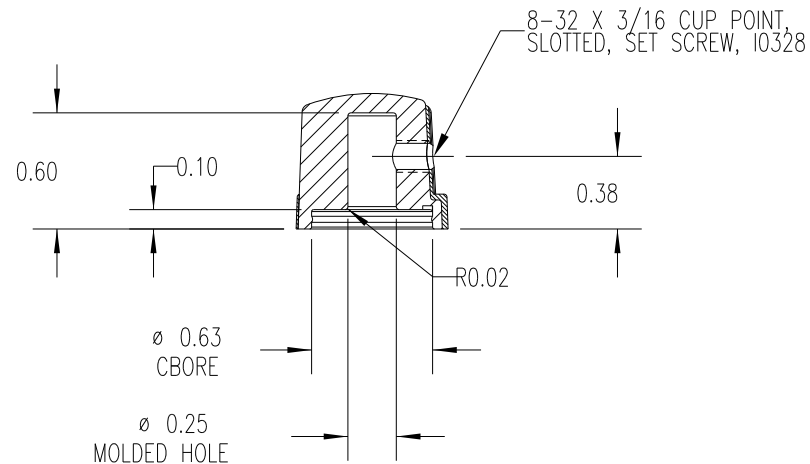
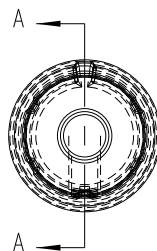
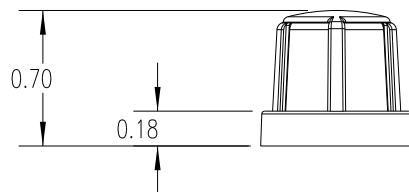
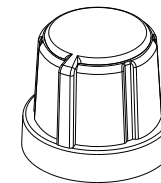
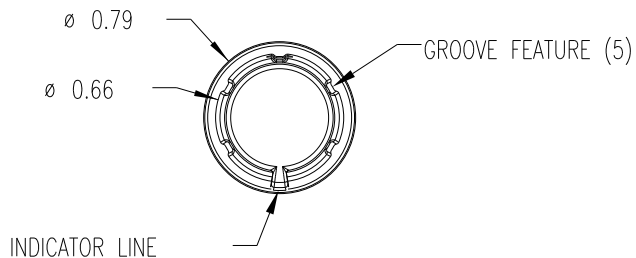

SECTION A-A

SUBSTRATE MATERIAL: POLYPROPYLENE (CLD)
COLOR: WHITE (PC23083)

OVERMOLD MATERIAL: TPE (TPE3)
COLOR: BLACK

| | | | | |
|---|----------------------------------|---------|--|--|
| TOLERANCES: UNLESS OTHERWISE SPECIFIED | DO NOT SCALE DRAWING | | | |
| DECIMALS: X.XXX ± .005 X.XX ± .015 | MM: X.XX ± 0.15MM X.X ± 0.4MM | | | |
| FRACTIONS ± 1/64 | ANG. ± 1° | CHANGES | | |