

RH-A3 | Tubular handles

Aluminium

METRIC



HANDLE SHANKS

Black anodised aluminium, semi-glossy finish.
Threaded blind holes.

TUBE

Extruded aluminium, ground surface, anodised in black colour.

SPECIAL EXECUTIONS ON REQUEST

- Stainless steel tube.
- Different lengths.
- Tubes and handle shanks in different colour combinations (black, natural).



RH-TL.A3 | Tubular handles

Aluminium and stainless steel

METRIC



HANDLE SHANKS

Extruded aluminium, anodised in natural colour, semi-glossy finish.
Threaded blind holes.

TUBE

AISI 304 stainless steel, ground surface.

SPECIAL EXECUTIONS ON REQUEST

Different lengths.



Conversion Table	
1 mm = 0.039 inch	
L	
mm	inch
220	8.66
270	10.63
320	12.60
420	16.53

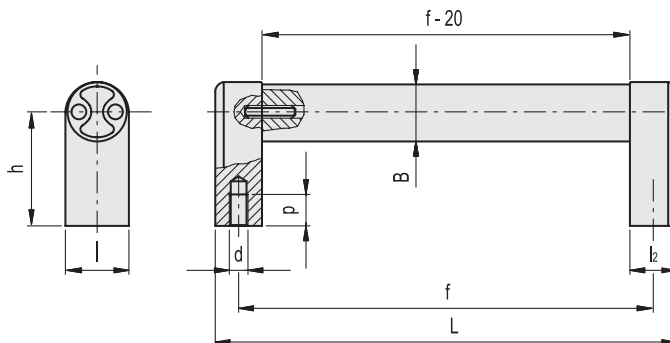

METRIC

Code	f	L	d	p	B	h	l	l ₂	⚖
RHA3-25.200.S04	200	220	M8	15	25	48	26	20	280
RHA3-25.250.S04	250	270	M8	15	25	48	26	20	310
RHA3-25.300.S04	300	320	M8	15	25	48	26	20	350
RHA3-25.400.S04	400	420	M8	15	25	48	26	20	409

INOX STAINLESS STEEL

METRIC

Code	f	d	p	L	B	h	l	l ₂	⚖
RHTL.A3-25.200.37	200	M8	15	220	25	48	26	20	398
RHTL.A3-25.300.37	300	M8	15	320	25	48	26	20	516
RHTL.A3-25.400.37	400	M8	15	420	25	48	26	20	634

- 1
- 2
- 3
- 4
- 5
- 6
- 7
- 8
- 9
- 10
- 11
- 12
- 13
- 14
- 15
- 16
- 17
- 18

Lift & Pull handles