

THIS DRAWING IS UNPUBLISHED. RELEASED FOR PUBLICATION  
 © COPYRIGHT - By - ALL RIGHTS RESERVED.

LOC		DIST		REVISIONS			
P	LTR	DESCRIPTION	DATE	DWN	APVD		
AD	00						
	C2	REVISED PER ECO-14-012660	19AUG2014	NK	RH		

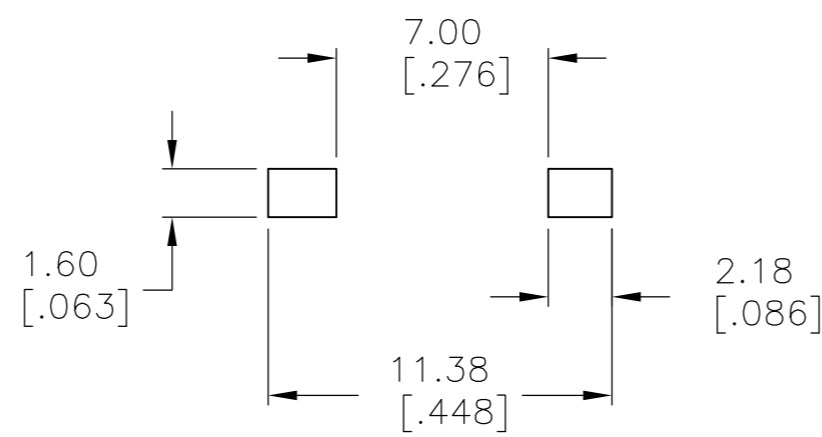
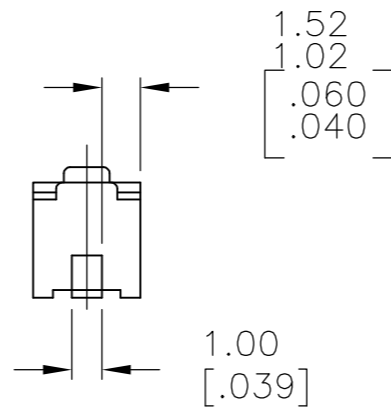
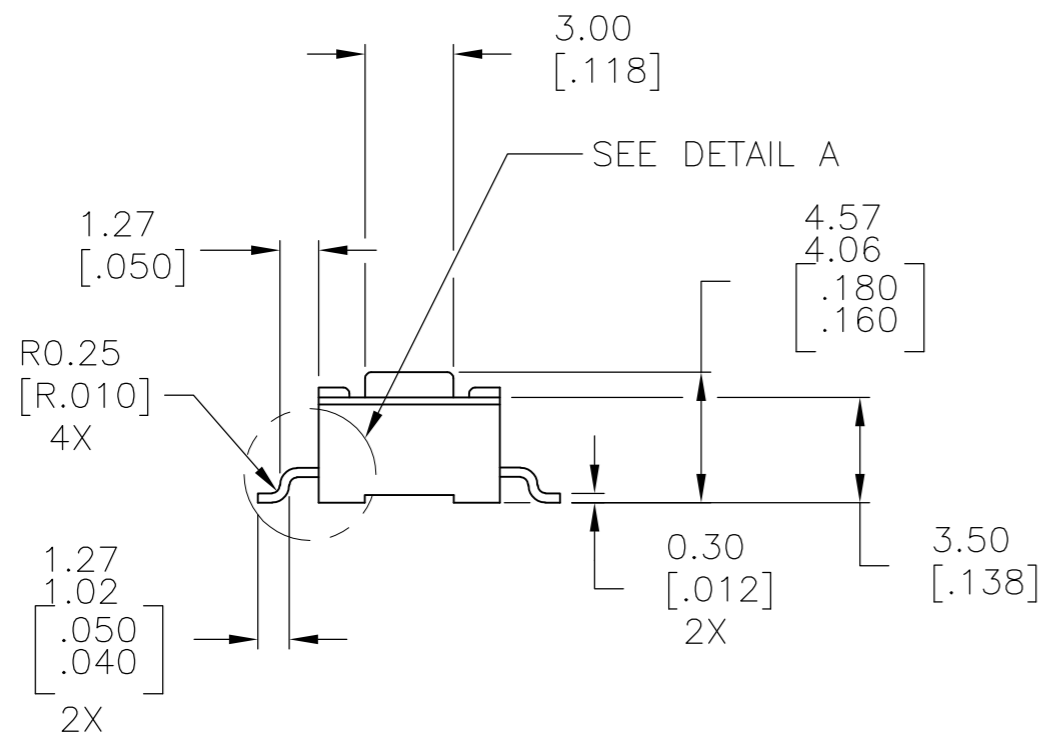
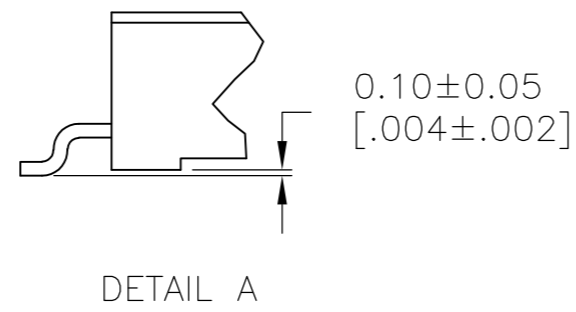
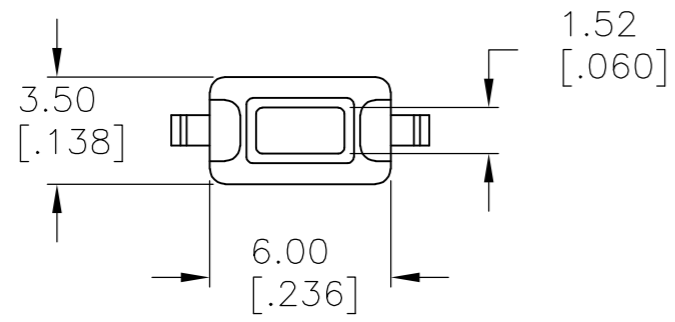

**CIRCUIT DIAGRAM**

NOTE: TERMINAL NUMBERS ARE FOR REFERENCE ONLY AND DO NOT APPEAR ON SWITCHES.

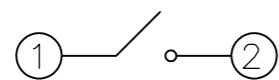

**SPECIFICATIONS:**

**MATERIALS:**

CASE: NYLON 46, G30, BROWN  
 COVER: STAINLESS STEEL  
 ACTUATOR BUTTON: PPS, BLACK.  
 MOVING CONTACT: 301 STAINLESS STEEL, 20μ" Ag CLAD.  
 FIXED CONTACT/TERMINALS: BRASS, 40μ", Ag PLATE.

**ELECTRICAL:**

MAX CONTACT RATING: 50MILLIAMPS@24V DC  
 MIN CONTACT RATING: 10MICROAMPS@1V DC  
 INITIAL CONTACT RESISTANCE: 100 MILLIOHMS MAX.  
 INSULATION RESISTANCE: 500 MEGOHMS MIN @ 500 VDC.  
 DIELECTRIC STRENGTH: 500 VAC 50/60 Hz FOR 1 MINUTE  
 LIFE EXPECTANCY: 20,000 CYCLES MIN.

**MECHANICAL:**

ACTUATION FORCE: SEE TABLE  
 ACTUATION TRAVEL: 0.25mm [.010"] APPROX.

**ENVIRONMENTAL:**

OPERATING TEMPERATURE: -35°C TO +85°C  
 STORAGE TEMPERATURE: -35°C TO +85°C  
 SOLDER HEAT RESISTANCE PER 109-201, COND B  
 SOLDERABILITY SPEC EIA-364-52, CLASS 1, CATEGORY 2

**NOTES:**

- ALL MATERIALS AND FINISHES SHALL COMPLY WITH EU DIRECTIVE 2002/95/EC OF 27JAN2003 (ROHS).
- SUBCONTRACTOR TO NOTE PART NUMBER MANUFACTURING LOT NUMBER AND QUANTITY ON EACH PACKAGE.
- PARTS ARE TO BE COMMERCIALY FREE OF ALL BURRS (MAX. OF 5% OF MATERIAL THICKNESS). NO LOOSE BURRS PERMITTED.
- TERMINAL TO BE FLUSH TO THE CASE BOTTOM, SEE DETAIL A.

180 ±50 gm.	FSMSMTR	1437566-4
180 ±50 gm.	FSMSM	1437566-3
ACTUATION FORCE	OLD T&B PART NUMBER	PART NO.

THIS DRAWING IS A CONTROLLED DOCUMENT.		DWN	12FEB96	<b>STE</b> TE Connectivity	
		CHK	-		
DIMENSIONS: mm [INCHES]		TOLERANCES UNLESS OTHERWISE SPECIFIED:		NAME	
		0 PLC ± -		S.KIRCORIAN	
		1 PLC ± -		W.MONTAGUE	
		2 PLC ± 0.30[.012]		23FEB96	
		3 PLC ± -		PRODUCT SPEC	
		4 PLC ± -		APPLICATION SPEC	
		ANGLES ± 1°		SIZE	
MATERIAL SEE SPECIFICATIONS		FINISH SEE SPECIFICATIONS		CAGE CODE	
				A2 00779	
		WEIGHT -		DRAWING NO	
				C=1437566-3	
		CUSTOMER DRAWING		RESTRICTED TO	
		SCALE 4:1		SHEET 1 of 1	
				REV C2	