

Spezifikation für Freigabe / specification for release

Kunde / customer :

Artikelnummer / part number :

S14100039



Bezeichnung : **STROMKOMPENSIERTE DROSSEL WE-CMB**

description : **COMMON MODE CHOKE WE-CMB**

DATUM / DATE : 2015-07-23

A Mechanische Abmessungen / dimensions:

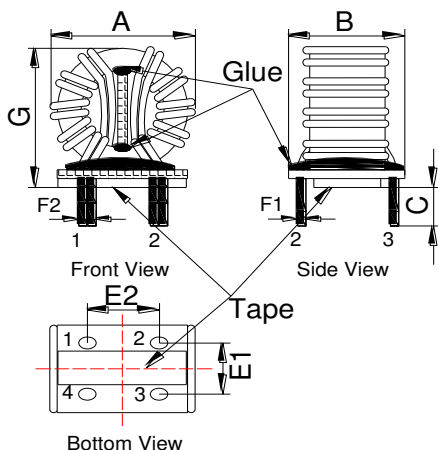

A	29,0 max.	mm
B	20,0 max.	mm
C	4,5 ± 0,5	mm
E1	12,0 ± 0,5	mm
E2	10,0 ± 0,5	mm
F1	1,8 max.	mm
F2	3,3 max.	mm
G	29,0 max.	mm

B Elektrische Eigenschaften / electrical properties:

Eigenschaften / properties	Testbedingungen / test conditions		Wert / value	Einheit / unit	tol.
Leerlauf-Induktivität / inductance	10 kHz / 50µA	L_0	0,285	mH	±30%
DC-Widerstand / DC-resistance	@ 20°C	R_{DC}	1,6	mΩ	max.
Nennstrom / nominal current		I_{DC}	25,0	A	max.
Nennspannung / nominal voltage		U_N	250	V _{AC}	max.

C Schaltbild / schematic:

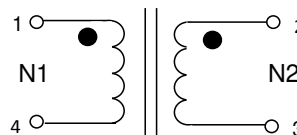

D Prüfgeräte / test equipment:

WAYNE KERR WK3260B/WK3265 für/for L_0/L_N und/and RDC
HP 34401 A für/for I_N

E Testbedingungen / test conditions:

Luftfeuchtigkeit / humidity: 33%
 Umgebungstemperatur / temperature: +25°C
 Prüfspannung / testing voltage: 1500 V, 50 Hz
 3mA , 2 sec.

F Werkstoffe & Zulassungen / material & approvals

Sockel / base: UL94V-0
 Draht / wire: Class F (155°C)
 Verguß / molding: UL94V-2
 Abstandhalter / spacer: UL94V-0

G Eigenschaften / general specifications:

Klimabeständigkeit / climatic class: 40/125/21
 Betriebstemp. / operating temperature: -40°C - + 125°C
 Übertemperatur / temperature rise: < 55 K
 It is recommended that the temperature of the part does not exceed 125°C under worst case operating conditions.

Freigabe erteilt / general release:	Kunde / customer		
Datum / date	Unterschrift / signature		
Geprüft / checked	Würth Elektronik		
	HasA	Version 3	15-07-23
	HasA	Version 2	15-03-05
	HasA	Version 1	14-04-15
Kontrolliert / approved	Name	Änderung / modification	Datum / date

This electronic component has been designed and developed for usage in general electronic equipment. Before incorporating this component into any equipment where higher safety and reliability is especially required or if there is the possibility of direct damage or injury to human body, for example in the range of aerospace, aviation, nuclear control, submarine, transportation, (automotive control, train control, ship control), transportation signal, disaster prevention, medical, public information network etc, Würth Elektronik eiSos GmbH must be informed before the design-in stage. In addition, sufficient reliability evaluation checks for safety must be performed on every electronic component which is used in electrical circuits that require high safety and reliability functions or performance.

Würth Elektronik eiSos GmbH & Co. KG

D-74638 Waldenburg · Max-Eyth-Strasse 1 -3 · Germany · Telefon (+49) (0) 7942 - 945 - 0 · Telefax (+49) (0) 7942 - 945 - 400
<http://www.we-online.com>

Spezifikation für Freigabe / specification for release

Kunde / customer :

Artikelnummer / part number : **S14100039**



Bezeichnung : **STROMKOMPENSIERTE DROSSEL WE-CMB**
 description : **COMMON MODE CHOKE WE-CMB**

WÜRTH ELEKTRONIK

DATUM / DATE : 2015-07-23

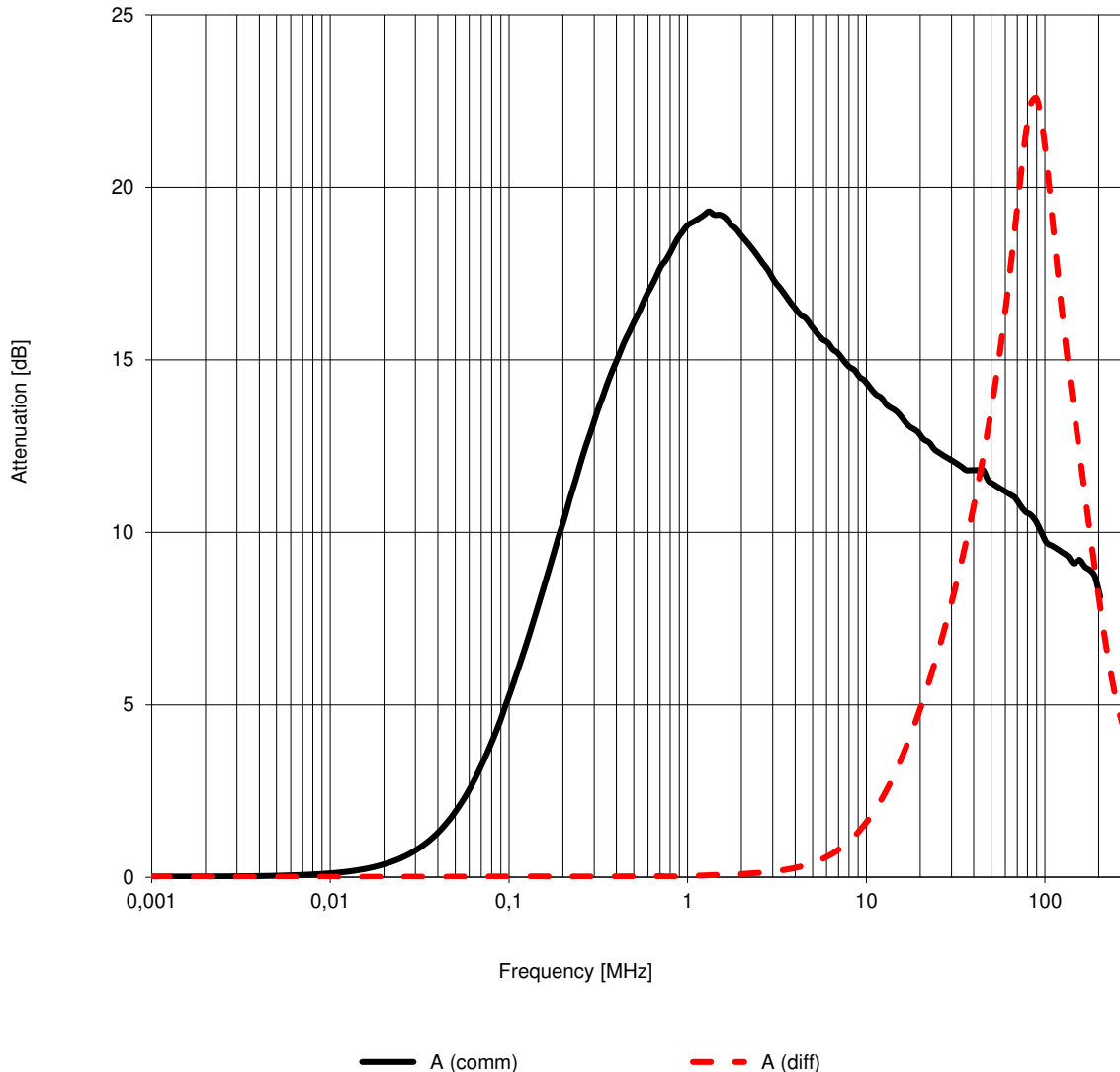

Freigabe erteilt / general release:	Kunde / customer			
Datum / date	Unterschrift / signature			
	Würth Elektronik	HasA	Version 3	15-07-23
		HasA	Version 2	15-03-05
		HasA	Version 1	14-04-15
Geprüft / checked	Kontrolliert / approved	Name	Änderung / modification	Datum / date

This electronic component has been designed and developed for usage in general electronic equipment. Before incorporating this component into any equipment where higher safety and reliability is especially required or if there is the possibility of direct damage or injury to human body, for example in the range of aerospace, aviation, nuclear control, submarine, transportation, (automotive control, train control, ship control), transportation signal, disaster prevention, medical, public information network etc, Würth Elektronik eiSos GmbH must be informed before the design-in stage. In addition, sufficient reliability evaluation checks for safety must be performed on every electronic component which is used in electrical circuits that require high safety and reliability functions or performance.

Würth Elektronik eiSos GmbH & Co. KG

D-74638 Waldenburg · Max-Eyth-Strasse 1 -3 · Germany · Telefon (+49) (0) 7942 - 945 - 0 · Telefax (+49) (0) 7942 - 945 - 400
<http://www.we-online.com>