

REV.	DESCRIPTION	DATE
A	New Drawing	2014/02/26

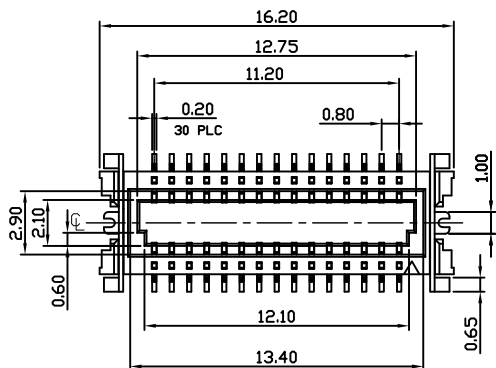

Compliance with:
 PCIe4.0(16GTS),
 USB4 Gen3(40Gbps),
 USB3.2 Gen2(10Gbps),
 USB3.2 Gen2 Type C(10Gbps).
 Mating with:
 "BACA-030G1140NWLI-B"

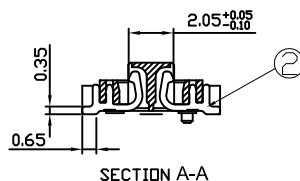

LTR	Part Name	Material	Description	QTY
1	Housing	LCP UL94V-0	+30%GF 260°C for 10 Seconds. Initial : 1000M Ohms Min.	1
2	Contact	Bronze C5191	Current Rating : 0.5 A Initial : 30m Ohms Max.	30
3	Fitting Nail	Brass	Current Rating : 0.5 A Initial : 30m Ohms Max.	2

Temperature Rating : -40°C ~ +105°C .
 Dielectric Withstanding Voltage : 300 V AC/Min

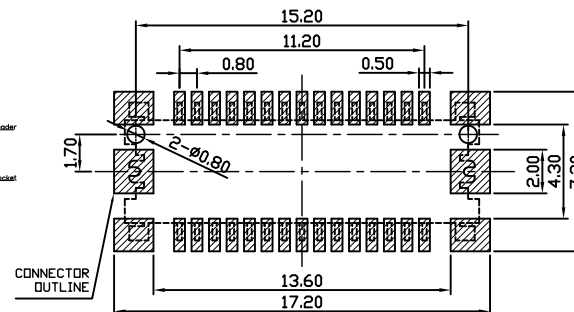
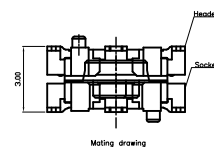
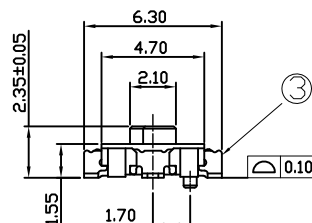
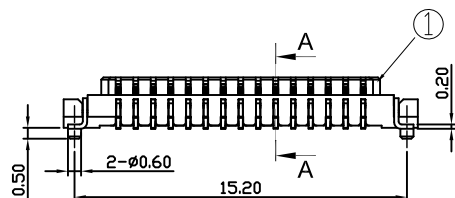

▨ : STAND OFF AREA
 TOLERANCE: ±0.05
 RECOMMENDED PCB LAYOUT
 (TOP VIEW)

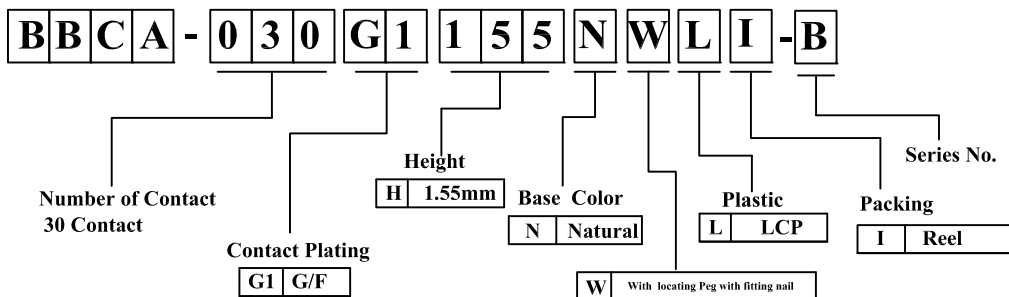

RoHS compliant

Superior Tech Co., Ltd.

General Tolerance		TITLE	PH0.8 BTOB H1.5 30PIN Male	
X.	± 0.5	DRAWN	DATE	NO.
.X	± 0.3	Tom	02-26-14'	002
.XX	± 0.2	CHECK	DATE	PART NO.
.XXX	± 0.1	APPROVED	DATE	BBCA-030G1155NWLI-B
Angle	± 5°			CUSTOMER NO. DK

REV.	UNIT	SCALE	
A	mm	1:1	

(Q2-R03-01A) ST-R05-07

LTR	Part Name	Material	Description	QTY
1	Reel	Ps	UL94V-0	1

REV.	DESCRIPTION	DATE
A	New Drawing	2017/07/26

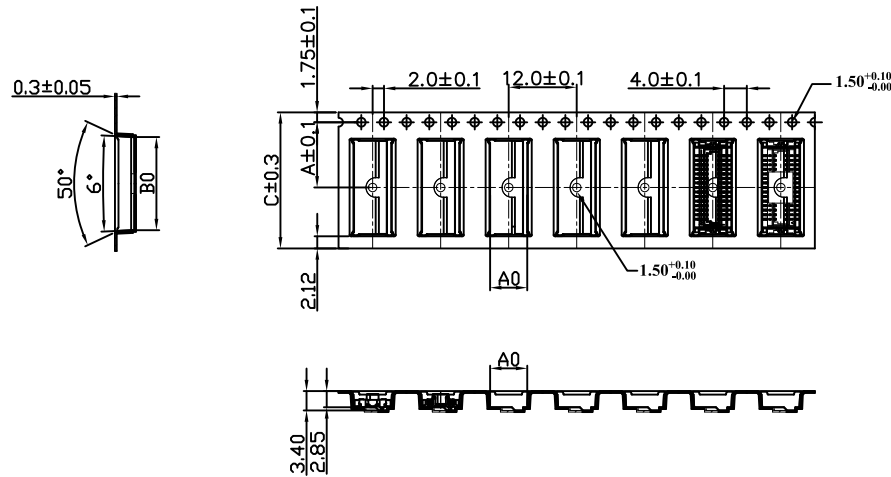
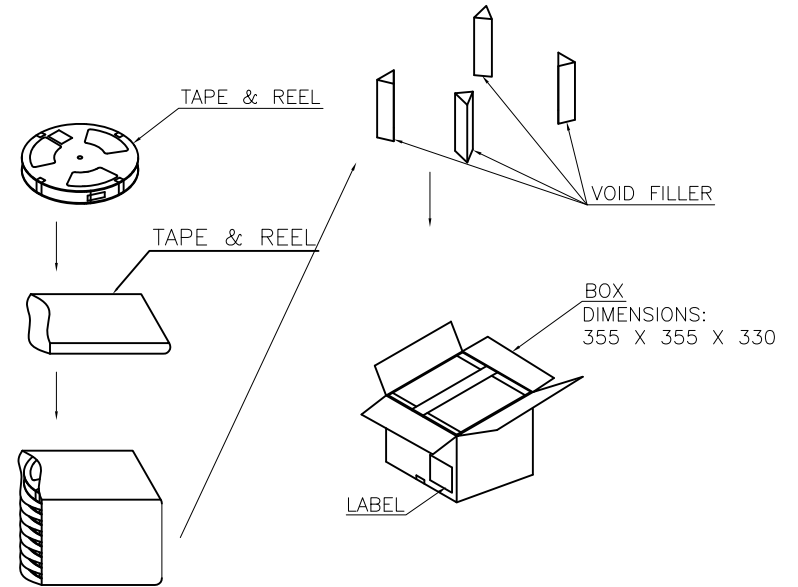
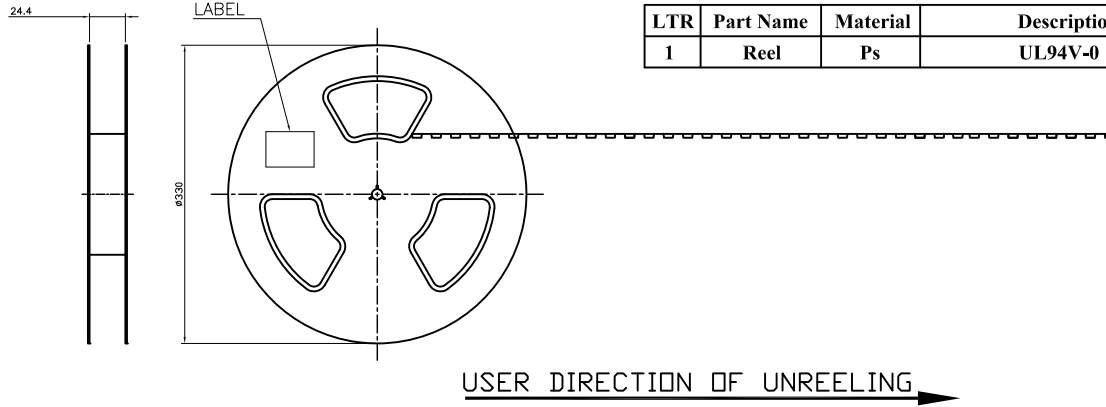

Note:
 1.All dimensions meet EIA-481-C requirements.
 2.Thickness : 0.3±0.05mm
 3.Play belt space: front space 13, back space 25

PIN No.	PCS/R	R/CTN
30PIN	1500 PCS	11 R

ITEM	A	A ₀	B0	C	
DIM	11.51±0.1	6.55±0.10	16.44±0.1	24.0±0.30	24.40 ⁺² ₋₀

Superior Tech Co., Ltd.

REV.	A	UNIT	mm	SCALE	1:1
------	---	------	----	-------	-----

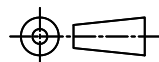

General Tolerance	TITLE	BBCA-030G1155NWLI-B & BACA-030G1140NWLI-B_Packing	
X. ± 0.5	DRAWN	DATE	NO.
.X ± 0.3	Andy	2017/07/26	002
.XX ± 0.2	CHECK	DATE	PART NO.
.XXX ± 0.1			BBCA-030G1155NWLI-B/ BACA-030G1140NWLI-B
Angle	APPROVED	DATE	CUSTOMER NO.
± 5°			DK

(Q2-R03-01A) ST-R05-07