

PART NUMBER	ITEM ①		ITEM ②	ITEM ③	ITEM ④
	HANDLE	COLOR	BODY	SPRING	STUD
108-1761-101	NYLON	WHITE	BRASS NICKEL PL .0001 MIN	NICKEL SILVER NICKEL PL .0001 MIN	BRASS BRIGHT TIN PL .0001 MIN OVER NICKEL PL .00005 MIN
108-1762-101		RED			
108-1763-101		BLACK			
108-1764-101		GREEN			
108-1765-101					
108-1766-101		ORANGE			
108-1767-101		YELLOW			
108-1768-101		BROWN			
108-1769-101					
108-1770-101		BLUE			
108-1771-101					
108-1772-101		VIOLET			
108-1773-101		GRAY			
108-1774-101					
108-1775-101					
108-1776-101					
108-1777-101					
108-1778-101					
108-1779-101					
108-1780-101					

DRAWING NO. B-108-1761/1780-101	
0	REVISIONS
***** * REVISION NUMBER FOLLOWED BY AN ALPHA * * CHARACTER INDICATES DRAWING CLARIFI- * * CATION OR PART NUMBER ADDITION ONLY. * *****	
14a	9-13-94 R S T R H W A J C K B ECN 42639
DIA .220±.010 WAS DIA .228±.005	
14b	2-29-08 P C R M J A S J J C 3-5-08 T M B U N ECN 51393
1.000±.020 WAS 1.000±.010, DIA .288 +.010 -.015 WAS DIA .220±.010 ***** * REVISION NUMBER FOLLOWED BY AN ALPHA * * CHARACTER INDICATES DRAWING CLARIFI- * * CATION OR PART NUMBER ADDITION ONLY. * *****	
14c	6-3-08 P R M T J A J J J C 6-10-08 T B U S N ECN 51531

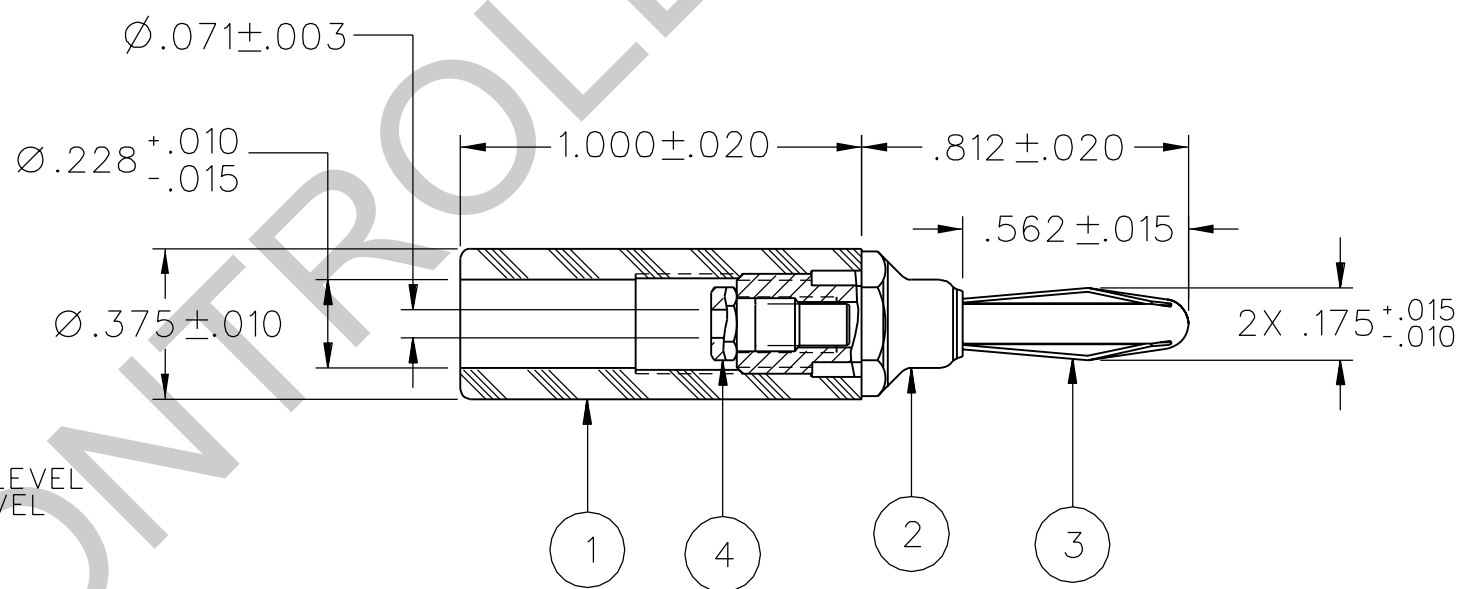

CUSTOMER DRAWING

THIS DRAWING TO BE INTERPRETED  
PER ASME Y 14.5M - 1994

"μ STATION"

COMPANY CONFIDENTIAL

NOTES:

1. SPECIFICATIONS:

ELECTRICAL:

CURRENT RATING: 15 AMPS DC MINIMUM  
DIELECTRIC WITHSTANDING VOLTAGE: 3500 VRMS MIN AT SEA LEVEL  
RECOMMENDED WORKING VOLTAGE: 1750 VRMS MAX AT SEA LEVEL  
INSULATION RESISTANCE: 5000 MEGOHMS MIN  
CONTACT RESISTANCE: 10 MILLIOHMS MAXIMUM

MECHANICAL:

INSERTION/WITHDRAWAL FORCE: 1.0 - 12.0 POUNDS  
CONTACT SPRING RETENTION FORCE: 15 LBS MINIMUM  
WIRE ACCEPTABILITY: 16 AWG OR SMALLER  
WIRE ATTACHMENT: SOLDER OR FLARE AND CLAMP USING THREADED STUD  
MATING BANANA JACK DIAMETER: .166 NOMINAL  
DURABILITY: 1000 CYCLES MINIMUM

ENVIRONMENTAL:

(MEETS OR EXCEEDS THE APPLICABLE PARAGRAPH OF MIL-C-28901)  
OPERATING TEMPERATURE: -55 DEG C TO 85 DEG C.  
TEMPERATURE RISE AT RATED CURRENT: 10 DEG C MAXIMUM  
CORROSION: MIL-STD-1344, METHOD 1001, CONDITION B  
SHOCK: MIL-STD-1344, METHOD 2004, CONDITION G  
VIBRATION: MIL-STD-1344, METHOD 2005, CONDITION I  
HUMIDITY: MIL-STD-1344, METHOD 1002, CONDITION B

TOLERANCE UNLESS OTHERWISE SPECIFIED		DRAWN BY	DATE
DECIMALS	mm	SWC	3-31-94
.XX	_____	CHECKED BY	DATE
.XXX	_____	TAK	9-19-94
MATL	_____	APPROVED BY	DATE
FINISH	_____	RJB	9-20-94
		RELEASE DATE	9-20-94
		U/M	SCALE 2:1

 <p><b>Cinch</b> CONNECTIVITY SOLUTIONS a bel group</p>	<p>Cinch Connectivity Solutions P.O. Box 1732 Waseca, MN 56093 1-800-247-8256</p>	
	<p>TITLE ASSEMBLY, BANANA PLUG INSULATED HANDLE, HEX BODY SOLDER OR SOLDERLESS STUD</p>	
<p>SHEET 2 OF 2</p>	<p>DRAWING NO. B-108-1761/1780-101</p>	