

FEATURES

- Complies With Universal Serial Bus Specification Rev. 2.0 (USB 2.0)
- Transmits and Receives Serial Data at Both Full-Speed (12-Mbit/s) and Low-Speed (1.5-Mbit/s) Data Rates
- Integrated Bypassable 5-V to 3.3-V Voltage Regulator for Powering Via USB VBUS
- Low-Power Operation, Ideal for Portable Equipment
- Meets the IEC-61000-4-2 Contact ($\pm 9\text{KV}$) and Air-gap ($\pm 9\text{KV}$) ESD Ratings
- Separate I/O Supply With Operation Down to 1.65 V
- Very-Low Power Consumption to Meet USB Suspend Current Requirements
- No Power-Supply Sequencing Requirements

APPLICATIONS

- Cellular Phones
- Personal Digital Assistants (PDAs)
- Handheld Computers

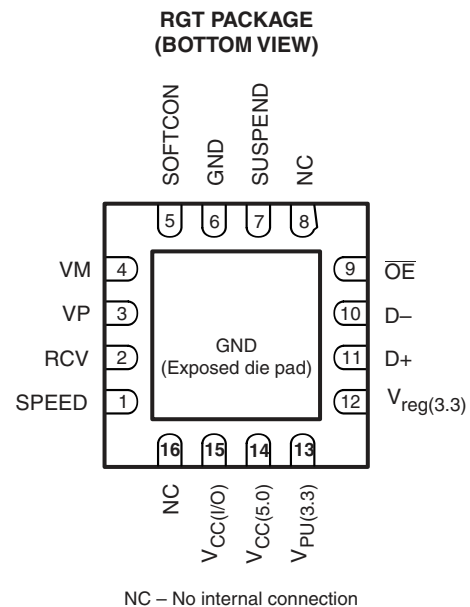
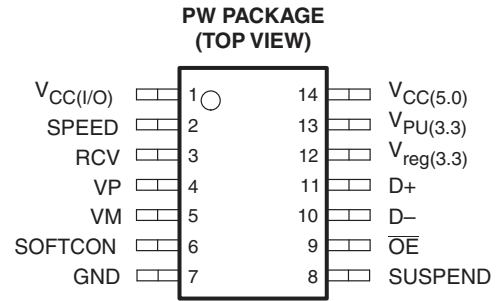

DESCRIPTION/ORDERING INFORMATION

The TUSB2551 is a single-chip transceiver that complies with the physical-layer specifications of universal serial bus (USB) 2.0. The device supports both full-speed (12-Mbit/s) and low-speed (1.5-Mbit/s) operation. The TUSB2551 delivers superior edge rate control, producing crisper eye diagrams, which ease the task of passing USB compliance testing.

A dual supply-voltage operation allows the TUSB2551 to reference the system interface I/O signals to a supply voltage down to 1.6 V, while independently powered by the USB $V_{CC(5.0)}$. This allows the system interface to operate at its core voltage without the addition of buffering logic, and also reduce system operating current.

ORDERING INFORMATION

T_A	PACKAGE ⁽¹⁾⁽²⁾		ORDERABLE PART NUMBER	TOP-SIDE MARKING
	–40°C to 85°C	QFN – RGT	Reel of 2000	TUSB2551RGTR
TSSOP – PW		Reel of 3000	TUSB2551PWR	TU2551

(1) Package drawings, thermal data, and symbolization are available at www.ti.com/packaging.

(2) For the most current package and ordering information, see the Package Option Addendum at the end of this document, or see the TI website at www.ti.com.



Please be aware that an important notice concerning availability, standard warranty, and use in critical applications of Texas Instruments semiconductor products and disclaimers thereto appears at the end of this data sheet.

BLOCK DIAGRAM

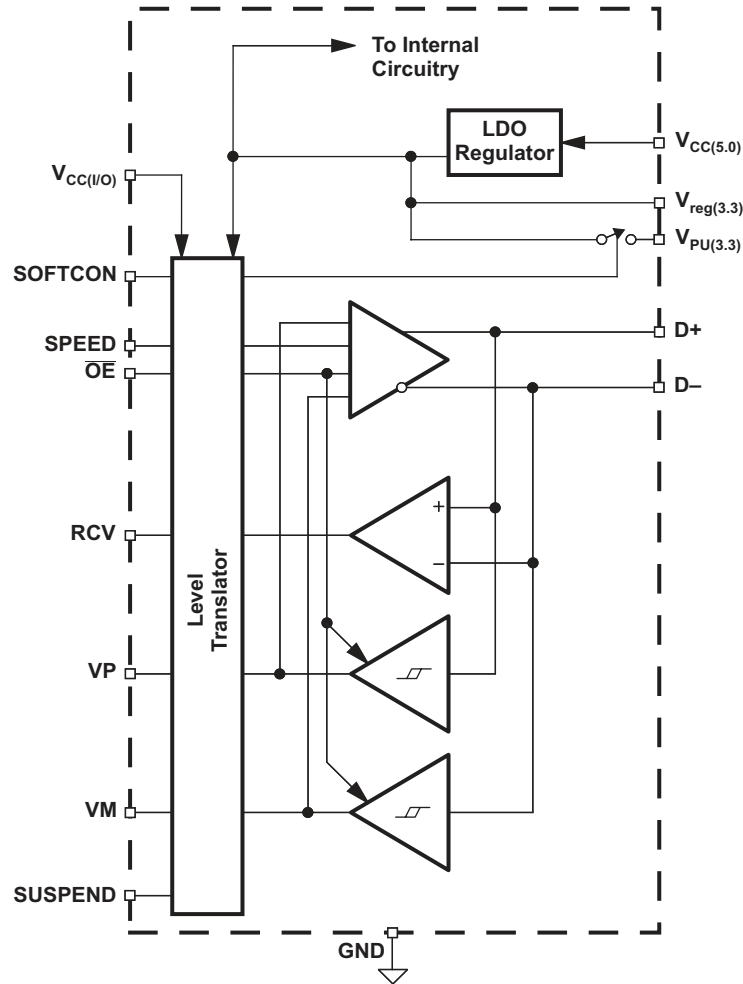

TERMINAL FUNCTIONS

TERMINAL			I/O	DESCRIPTION
NAME	RGT NO.	PW NO.		
V _{CC(I/O)}	15	1	I	System interface supply voltage. Used to provide reference supply voltage for system I/O interface signaling.
SPEED	1	2	I	Speed. Edge-rate control: A logic HIGH operates at edge rates for full-speed operation. A logic LOW operates at edge rates for low-speed operation.
RCV	2	3	O	Receive data. Output for USB differential data.
VP	3	4	I/O	If $\overline{OE} = 1$, VP = Receiver output (+) If $\overline{OE} = 0$, VP = Driver input (+)
VM	4	5	I/O	If $\overline{OE} = 1$, VM = Receiver output (–) If $\overline{OE} = 0$, VM = Driver input (–)
SOFTCON	5	6	I	Soft connect. Controls state of V _{PU(3,3)} . Refer to V _{PU(3,3)} pin description for details.
GND	6	7		Ground reference
SUSPEND	7	8	I	Suspend. Active high. Turns off internal circuits to reduce supply current.
NC	8, 16			No internal connection
\overline{OE}	9	9	I	Output enable. Active low. Enables the transceiver to transmit data onto the bus. When inactive, the transceiver is in the receive mode.
D–, D+	10, 11	10, 11	I/O	Differential data lines conforming to the USB standard
V _{reg(3.3)}	12	12	O	3.3-V reference supply. Requires a minimum 0.1- μ F decoupling capacitor for stability. A 1- μ F capacitor is recommended.
V _{PU(3.3)}	13	13	O	Pullup supply voltage. Used to connect 1.5-k Ω pullup speed detect resistor. If SOFTCON = 1, V _{PU(3.3)} is high impedance. If SOFTCON = 0, V _{PU(3.3)} = 3.3 V.
V _{CC(5.0)}	14	14	I	USB bus supply voltage. Used to power USB transceiver and internal circuitry.

FUNCTIONAL DESCRIPTION

FUNCTION SELECTION

SUSPEND	\overline{OE}	D+, D–	RCV	VP, VM	FUNCTION
0	0	Driving	Active	Active	Normal transmit mode
0	1	Receiving	Active	Active	Normal receive mode
1	0	Hi-Z	0	Not active	Low power state
1	1	Hi-Z	0	Active	Receiving during suspend (low power state) ⁽¹⁾

(1) During suspend, VP and VM are active in order to detect out-of-band signaling conditions.

TRUTH TABLE DURING NORMAL MODE

$\overline{OE} = 0$					
INPUT		OUTPUT			RESULT
VP	VM	D+	D–	RCV	
0	0	0	0	X ⁽¹⁾	SE0
0	1	0	1	0	Logic 0
1	0	1	0	1	Logic 1
1	1	1	1	X ⁽¹⁾	Undefined
$\overline{OE} = 1$					
Input		Output			RESULT
D+	D–	VP	VM	RCV	
0	0	0	0	X ⁽¹⁾	SE0
0	1	0	1	0	Logic 0
1	0	1	0	1	Logic 1
1	1	1	1	X ⁽¹⁾	Undefined

(1) X = Undefined

Power-Supply Configurations

The TUSB2551 can be used with different power-supply configurations, which can be dynamically changed. An overview is given in [Table 1](#).

- Normal mode – Both $V_{CC(I/O)}$ and $V_{CC(5.0)}$ or $V_{CC(5.0)}$ and $V_{reg(3.3)}$ are connected. For 5-V operation, $V_{CC(5.0)}$ is connected to a 5-V source (4 V to 5.5 V). The internal voltage regulator then produces 3.3 V for the USB connections. For 3.3-V operation, both $V_{CC(5.0)}$ and $V_{reg(3.3)}$ are connected to a 3.3-V source (3 V to 3.6 V). $V_{CC(I/O)}$ is independently connected to a voltage source (1.65 V to 3.6 V), depending on the supply voltage of the external circuit.
- Disable mode – $V_{CC(I/O)}$ is not connected; $V_{CC(5.0)}$ or $V_{CC(5.0)}$ and $V_{reg(3.3)}$ are connected. In this mode, the internal circuits of the TUSB2551 ensure that the D+ and D– pins are in 3-state, and the power consumption drops to the low-power (suspended) state level. Some hysteresis is built into the detection of $V_{CC(I/O)}$ lost.
- Sharing mode – $V_{CC(I/O)}$ is connected; $V_{CC(5.0)}$ and $V_{reg(3.3)}$ are not connected. In this mode, the D+ and D– pins are made 3-state, and the TUSB2551 allows external signals of up to 3.6 V to share the D+ and D– lines. The internal circuits of the TUSB2551 ensure that virtually no current (maximum 10 mA) is drawn via the D+ and D– lines. The power consumption through $V_{CC(I/O)}$ drops to the low-power (suspended) state level. Both the VP and VM pins are driven HIGH to indicate this mode. Pin RCV is made LOW. Some hysteresis is built into the detection of $V_{reg(3.3)}$ lost.

Table 1. Power-Supply Configuration Overview

Configuration Mode	VBUS/VTRM	VIF	Notes
Normal	Connected	Connected	Normal supply configuration and operation.
Disconnect (D+/D– sharing)	Open	Connected	VP/VM are HIGH outputs, RCV is LOW. With OE# = 0 and SUSPEND = 1, data lines may be driven with external devices up to 3.6 V. With D+, D– floating, $I_{CC(I/O)}$ draws less than 1 μ A.
Disconnect	Ground	Connected	VP/VM are HIGH outputs, RCV is LOW. With D+, D– floating, $I_{CC(I/O)F}$ draws less than 1 μ A.
Disable Mode	Connected	Open	Logic controlled inputs pins are Hi-Z
Prohibited	Connected	Ground	Prohibited condition

Table 2. Pin States in Disable or Sharing Mode

PINS	DISABLE-MODE STATE	SHARING-MODE STATE
$V_{CC(5.0)}/V_{reg(3.3)}$	5-V input/3.3-V output, 3.3-V input/3.3-V input	Not present
$V_{CC(I/O)}$	Not present	1.65-V to 3.6-V input
$V_{PU(3.3)}$	High impedance (off)	High impedance (off)
D+, D–	High impedance	High impedance
VP, VM	Invalid ⁽¹⁾	H
RCV	Invalid ⁽¹⁾	L
Inputs (SPEED, SUSPEND, \overline{OE} , SOFTCON)	High impedance	High impedance

(1) High impedance or driven LOW

Power-Supply Input Options

The TUSB2551 has two power-supply input options.

- Internal regulator – $V_{CC(5.0)}$ is connected to 4 V to 5.5 V. The internal regulator is used to supply the internal circuitry with 3.3 V (nominal). $V_{reg(3.3)}$ becomes a 3.3-V output reference.
- Regulator bypass – $V_{CC(5.0)}$ and $V_{reg(3.3)}$ are connected to the same supply. The internal regulator is bypassed, and the internal circuitry is supplied directly from the $V_{reg(3.3)}$ power supply. The voltage range is 3 V to 3.6 V to comply with the USB specification.

The supply-voltage range for each input option is specified in [Table 3](#).

Table 3. Power-Supply Input Options

INPUT OPTION	$V_{CC(5.0)}$	$V_{reg(3.3)}$	$V_{CC(I/O)}$
Internal regulator	Supply input for internal regulator (4 V to 5.5 V)	Voltage-reference output (3.3 V, 300 μ A)	Supply input for digital I/O pins (1.4 V to 3.6 V)
Regulator bypass	Connected to $V_{reg(3.3)}$ with maximum voltage drop of 0.3 V (2.7 V to 3.6 V)	Supply input (3 V to 3.6 V)	Supply input for digital I/O pins (1.4 V to 3.6 V)

Electrostatic Discharge (ESD)

PIN NAME	ESD	TYP	UNIT
D+, D-, $V_{CC(5.0)}$	IEC61000-4-2, Air-Gap Discharge	± 9	kV
	IEC61000-4-2, Contact Discharge	± 9	
	Human-Body Model	± 15	
All other pins	Human-Body Model	± 2	kV

TUSB2551

ADVANCED UNIVERSAL SERIAL BUS TRANSCEIVER

SCES667–FEBRUARY 2008

ABSOLUTE MAXIMUM RATINGS⁽¹⁾

over operating free-air temperature range (unless otherwise noted)

		MIN	MAX	UNIT
$V_{CC(5.0)}$	Supply voltage range	-0.5	6	V
$V_{CC(I/O)}$	I/O supply voltage range	-0.5	4.6	V
$V_{reg(3.3)}$	Regulated voltage range	-0.5	4.6	V
V_I	DC input voltage range	-0.5	$V_{CC(I/O)} + 0.5$	mA
$I_{O(D+, D-)}$	Output Current (D+, D-)		±50	mA
I_O	Output Current (all others)		±15	mA
I_I	Input Current		±50	mA
T_{stg}	Storage temperature range	-65	150	°C

(1) Stresses beyond those listed under "absolute maximum ratings" may cause permanent damage to the device. These are stress ratings only, and functional operation of the device at these or any other conditions beyond those indicated under "recommended operating conditions" is not implied. Exposure to absolute-maximum-rated conditions for extended periods may affect device reliability.

RECOMMENDED OPERATING CONDITIONS

PARAMETER	TEST CONDITIONS	MIN	TYP	MAX	UNIT	
$V_{CC(5.0)}$	Supply voltage, internal regulator option	5-V operation	4	5	5.25	V
$V_{reg(3.3)}$	Supply voltage, regulator bypass option	3.3-V operation	3	3.3	3.6	V
$V_{CC(I/O)}$	I/O supply voltage		1.65		3.6	V
V_{IL}	Low-level input voltage ⁽¹⁾		$V_{CC(I/O)} - 0.3$		$0.15 V_{CC(I/O)}$	V
V_{IH}	High-level input voltage ⁽¹⁾		$0.85 V_{CC(I/O)}$		$V_{CC(I/O)} + 0.3$	V
D+, D-	Input voltage on analog I/O pins		0		3.6	V
T_c	Junction temperature range		-40		85	°C

(1) Specification applies to the following pins: SUSPEND, SPEED, RCV, SOFTCON, VP, VM, \overline{OE}

DC ELECTRICAL CHARACTERISTICS SYSTEM AND USB INTERFACE⁽¹⁾
 $V_{CC(I/O)} = 3.6\text{ V}$, $V_{CC(5.0)} = 5\text{ V}$ (unless otherwise noted), $T_A = 25\text{ }^\circ\text{C}$. Bold indicates specifications over temperature, -40°C to 85°C

PARAMETER		TEST CONDITIONS					MIN	TYP	MAX	UNIT	
V_{OH}	High-level output voltage ⁽²⁾	$I_{OH} = 20\text{ }\mu\text{A}$					$0.9 V_{CC(I/O)}$			V	
V_{OL}	Low-level output voltage ⁽²⁾	$I_{OL} = 20\text{ }\mu\text{A}$								V	
I_{IL}	Input leakage current ⁽²⁾						-5	1.5	5	μA	
$I_{CC(I/O)}$	$V_{CC(I/O)}$ supply current	SPEED	SUSPEND	OE	VOLTAGE	LOAD					
		1	0	1			$V_{CC(5.0)} = 5.25\text{ V}$, $V_{CC(I/O)} = 3.6\text{ V}$		1	5	μA
		1	0	0					1	5	
		0	0	1					1	5	
		0	0	0					1	5	
		0	1	0					1	5	
		1	0	0				f = 6 MHz, $C_L = 50\text{ pF}$	1	2	
		0	0	0			f = 750 kHz, $C_L = 600\text{ pF}$	260	280	μA	
$I_{CC(5.0)}$	$V_{CC(5.0)}$ supply current	1	0	1	$V_{CC(5.0)} = 5.25\text{ V}$, $V_{CC(I/O)} = 3.6\text{ V}$		800	1100	μA		
		1	0	0			3000	5000			
		0	0	1			230	350			
		0	0	0			400	700			
		0	1	0			130	200			
		1	0	0		f = 6 MHz, $C_L = 50\text{ pF}$	6	10		mA	
		0	0	0		f = 750 kHz, $C_L = 600\text{ pF}$	4..3	5			
		$I_{PU(3.3)LEAK}$	$V_{PU(3.3)}$ leakage current	SOFTCON = 1, $V_{PU(3.3)} = 0\text{ V}$					-5		5
$I_{CC(I/O)LEAK}$	$V_{CC(I/O)}$ leakage current	$V_{CC(I/O)} = 3.6\text{ V}$, $V_{CC(5.0)} = 0\text{ V}$					-5		5	μA	
$V_{PU(3.3)}$	Pullup output voltage	$I_{reg(3.3)} = 200\text{ }\mu\text{A}$, $V_{CC(5.0)} = 4\text{ V to }5.25\text{ V}$					3	3.3	3.6	V	
R_{SW}	$V_{PU(3.3)}$ switch resistance	$I_{reg(3.3)} = 10\text{ mA}$, $V_{CC(5.0)} = 4\text{ V to }5.25\text{ V}$						10		Ω	
ESD PROTECTION											
IEC-61000-4-2 (D+, D-, $V_{CC(5.0)}$ only)	Air-Gap Discharge	10 pulses						± 9		kV	
	Contact Discharge	10 pulses						± 9			

(1) Specification for packaged product only

(2) Specification applies to the following pins: RCV, VP, VM, OE.

TUSB2551 ADVANCED UNIVERSAL SERIAL BUS TRANSCEIVER

SCES667–FEBRUARY 2008



DC ELECTRICAL CHARACTERISTICS TRANSCEIVER⁽¹⁾

PARAMETER		TEST CONDITIONS	MIN	TYP	MAX	UNIT
LEAKAGE CURRENT						
I_{LO}	Hi-Z state data line leakage (suspend mode)	$0\text{ V} < V_{IN} < 3.3\text{ V}$, SUSPEND = 1	-10		10	μA
INPUT LEVELS						
V_{DI}	Differential input sensitivity	$ (D+) - (D-) $	0.2			V
V_{CM}	Differential common mode range	Includes V_{DI} range	0.8		2.5	V
V_{SE}	Single-ended receiver threshold		0.8		2	V
	Receiver hysteresis			200		mV
OUTPUT LEVELS						
V_{OL}	Static output low	$R_L = 1.5\text{ k}\Omega$ to 3.6 V			0.3	V
V_{OH}	Static output high	$R_L = 15\text{ k}\Omega$ to GND	2.8		3.6	V
CAPACITANCE						
C_{IN}	Transceiver capacitance	Pin to GND		10		pF
Z_{DRV}	Driver output resistance	Steady-state drive	1	6	11	Ω

(1) Specification for packaged product only

AC ELECTRICAL CHARACTERISTICS⁽¹⁾

PARAMETER		TEST CONDITIONS	MIN	MAX	UNIT
DRIVER CHARACTERISTICS (LOW SPEED)					
T_R	Transition rise time	$C_L = 200$ pF, See Figure 2 $C_L = 600$ pF	75	300	ns
T_F	Transition fall time	$C_L = 200$ pF, See Figure 2 $C_L = 600$ pF	75	300	ns
LRFM	Rise/fall time matching	T_R, T_F	80	125	%
V_{CRS}	Output signal crossover voltage		1.3	2	V
DRIVER CHARACTERISTICS (FULL SPEED)					
T_R	Transition rise time	$C_L = 50$ pF, See Figure 2	4	20	ns
T_F	Transition fall time	$C_L = 50$ pF, Figure 2	4	20	ns
FRFM	Rise/fall time matching	(T_R, T_F)	90	111.1	%
V_{CRS}	Output signal crossover voltage		1.3	2	V
TRANSCEIVER TIMING (FULL SPEED)					
t_{PVZ}	\overline{OE} to receiver 3-state delay	See Figure 1		15	ns
t_{PZD}	Receiver 3-state to transmit delay	See Figure 1	15		ns
t_{PDZ}	\overline{OE} to driver 3-state delay	See Figure 1		15	ns
t_{PZV}	Driver 3-state to receive delay	See Figure 1	15		ns
t_{PLH} t_{PHL}	V_P, V_M to D+, D– propagation delay	See Figure 4		17	ns
t_{PLH} t_{PHL}	D+, D– to RCV propagation delay	See Figure 3		17	ns
t_{PLH} t_{PHL}	D+, D– to V_P, V_M propagation delay	See Figure 3		10	ns

(1) Specification for packaged product only

TIMING DIAGRAMS

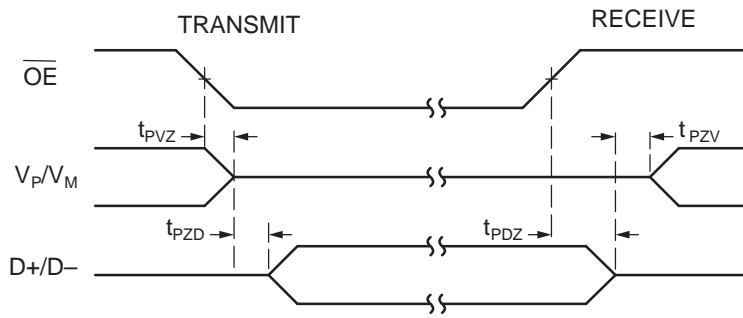

Figure 1. Enable and Disable Times

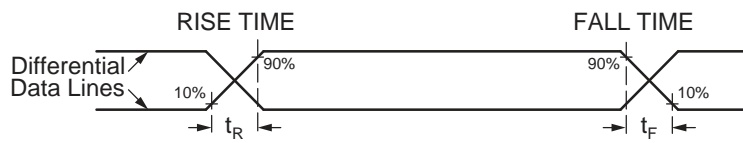

Figure 2. Rise and Fall Times

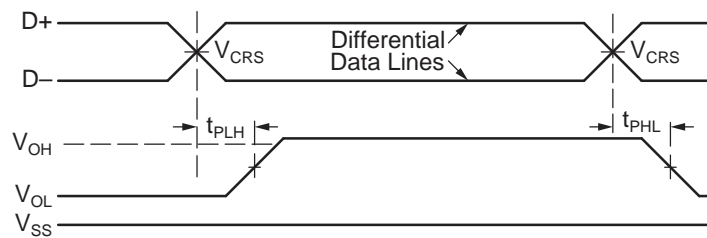

Figure 3. Receiver Propagation Delay

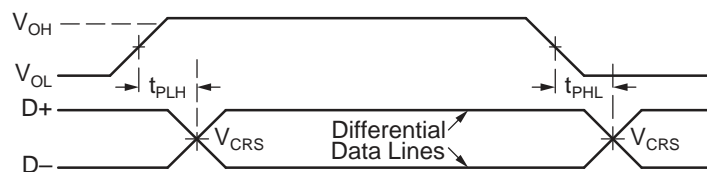

Figure 4. Driver Propagation Delay

TEST CIRCUITS

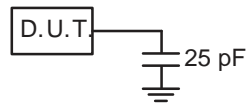

Figure 5. Load for V_p , V_M , RCV

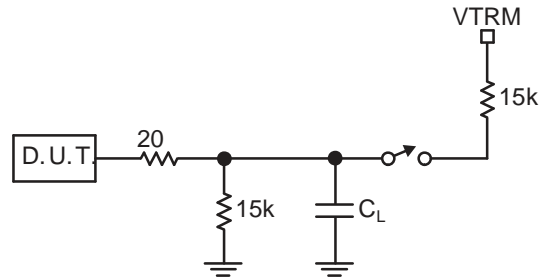

Figure 6. Load for D_+ , D_-

PACKAGING INFORMATION

Orderable Device	Status (1)	Package Type	Package Drawing	Pins	Package Qty	Eco Plan (2)	Lead finish/ Ball material (6)	MSL Peak Temp (3)	Op Temp (°C)	Device Marking (4/5)	Samples
TUSB2551PWR	NRND	TSSOP	PW	14	2000	RoHS & Green	NIPDAU	Level-1-260C-UNLIM	-40 to 85	TU2551	

(1) The marketing status values are defined as follows:

ACTIVE: Product device recommended for new designs.

LIFEBUY: TI has announced that the device will be discontinued, and a lifetime-buy period is in effect.

NRND: Not recommended for new designs. Device is in production to support existing customers, but TI does not recommend using this part in a new design.

PREVIEW: Device has been announced but is not in production. Samples may or may not be available.

OBSELETE: TI has discontinued the production of the device.

(2) **RoHS:** TI defines "RoHS" to mean semiconductor products that are compliant with the current EU RoHS requirements for all 10 RoHS substances, including the requirement that RoHS substance do not exceed 0.1% by weight in homogeneous materials. Where designed to be soldered at high temperatures, "RoHS" products are suitable for use in specified lead-free processes. TI may reference these types of products as "Pb-Free".

RoHS Exempt: TI defines "RoHS Exempt" to mean products that contain lead but are compliant with EU RoHS pursuant to a specific EU RoHS exemption.

Green: TI defines "Green" to mean the content of Chlorine (Cl) and Bromine (Br) based flame retardants meet JS709B low halogen requirements of <=1000ppm threshold. Antimony trioxide based flame retardants must also meet the <=1000ppm threshold requirement.

(3) MSL, Peak Temp. - The Moisture Sensitivity Level rating according to the JEDEC industry standard classifications, and peak solder temperature.

(4) There may be additional marking, which relates to the logo, the lot trace code information, or the environmental category on the device.

(5) Multiple Device Markings will be inside parentheses. Only one Device Marking contained in parentheses and separated by a "-" will appear on a device. If a line is indented then it is a continuation of the previous line and the two combined represent the entire Device Marking for that device.

(6) Lead finish/Ball material - Orderable Devices may have multiple material finish options. Finish options are separated by a vertical ruled line. Lead finish/Ball material values may wrap to two lines if the finish value exceeds the maximum column width.

Important Information and Disclaimer:The information provided on this page represents TI's knowledge and belief as of the date that it is provided. TI bases its knowledge and belief on information provided by third parties, and makes no representation or warranty as to the accuracy of such information. Efforts are underway to better integrate information from third parties. TI has taken and continues to take reasonable steps to provide representative and accurate information but may not have conducted destructive testing or chemical analysis on incoming materials and chemicals. TI and TI suppliers consider certain information to be proprietary, and thus CAS numbers and other limited information may not be available for release.

In no event shall TI's liability arising out of such information exceed the total purchase price of the TI part(s) at issue in this document sold by TI to Customer on an annual basis.

TAPE AND REEL INFORMATION

QUADRANT ASSIGNMENTS FOR PIN 1 ORIENTATION IN TAPE

*All dimensions are nominal

Device	Package Type	Package Drawing	Pins	SPQ	Reel Diameter (mm)	Reel Width W1 (mm)	A0 (mm)	B0 (mm)	K0 (mm)	P1 (mm)	W (mm)	Pin1 Quadrant
TUSB2551PWR	TSSOP	PW	14	2000	330.0	12.4	6.9	5.6	1.6	8.0	12.0	Q1

TAPE AND REEL BOX DIMENSIONS



*All dimensions are nominal

Device	Package Type	Package Drawing	Pins	SPQ	Length (mm)	Width (mm)	Height (mm)
TUSB2551PWR	TSSOP	PW	14	2000	356.0	356.0	35.0

MECHANICAL DATA

PW (R-PDSO-G14)

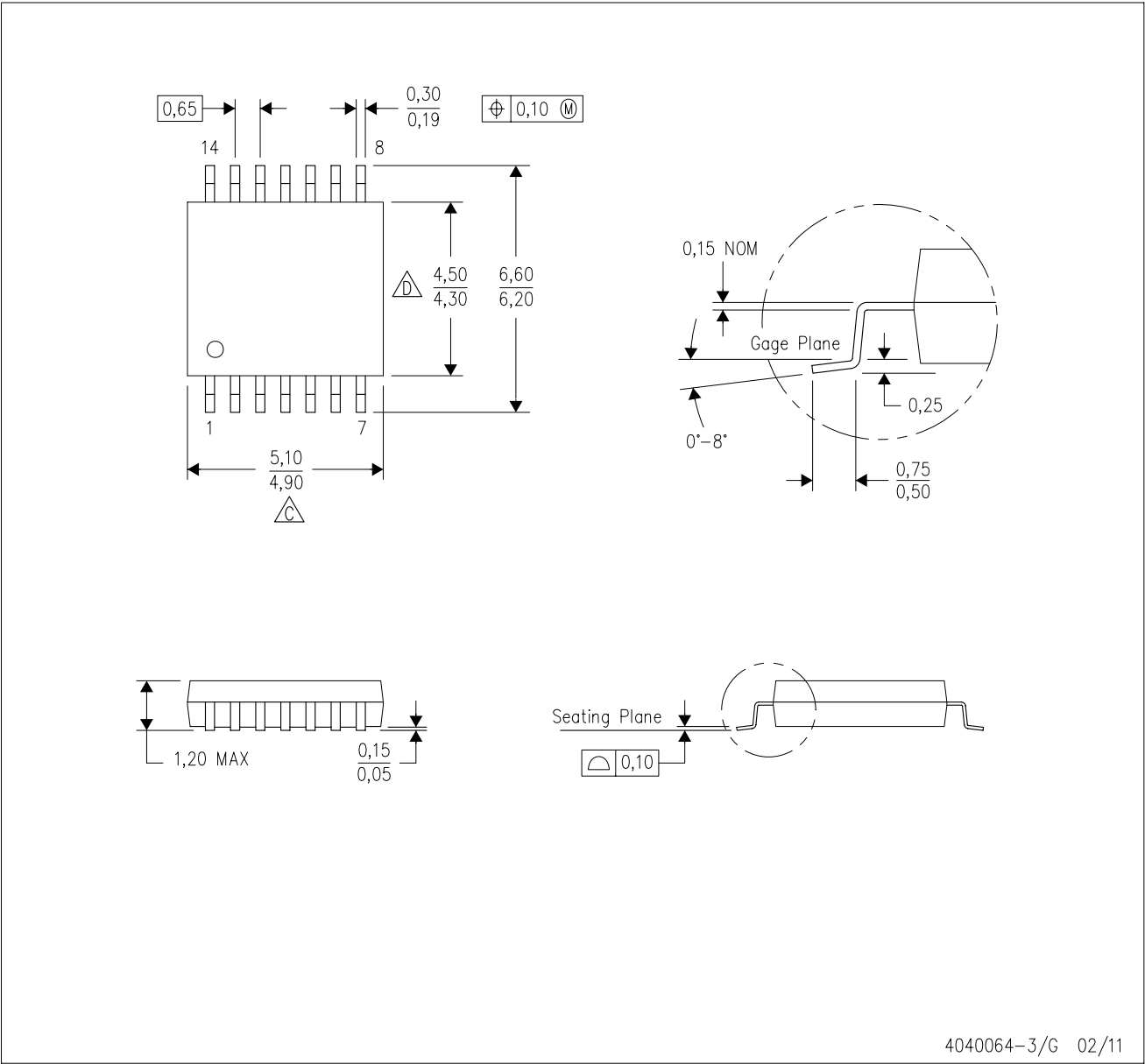
PLASTIC SMALL OUTLINE



4040064-3/G 02/11

- NOTES:
- A. All linear dimensions are in millimeters. Dimensioning and tolerancing per ASME Y14.5M-1994.
 - B. This drawing is subject to change without notice.
 - C. Body length does not include mold flash, protrusions, or gate burrs. Mold flash, protrusions, or gate burrs shall not exceed 0,15 each side.
 - D. Body width does not include interlead flash. Interlead flash shall not exceed 0,25 each side.
 - E. Falls within JEDEC MO-153

PW (R-PDSO-G14)

PLASTIC SMALL OUTLINE

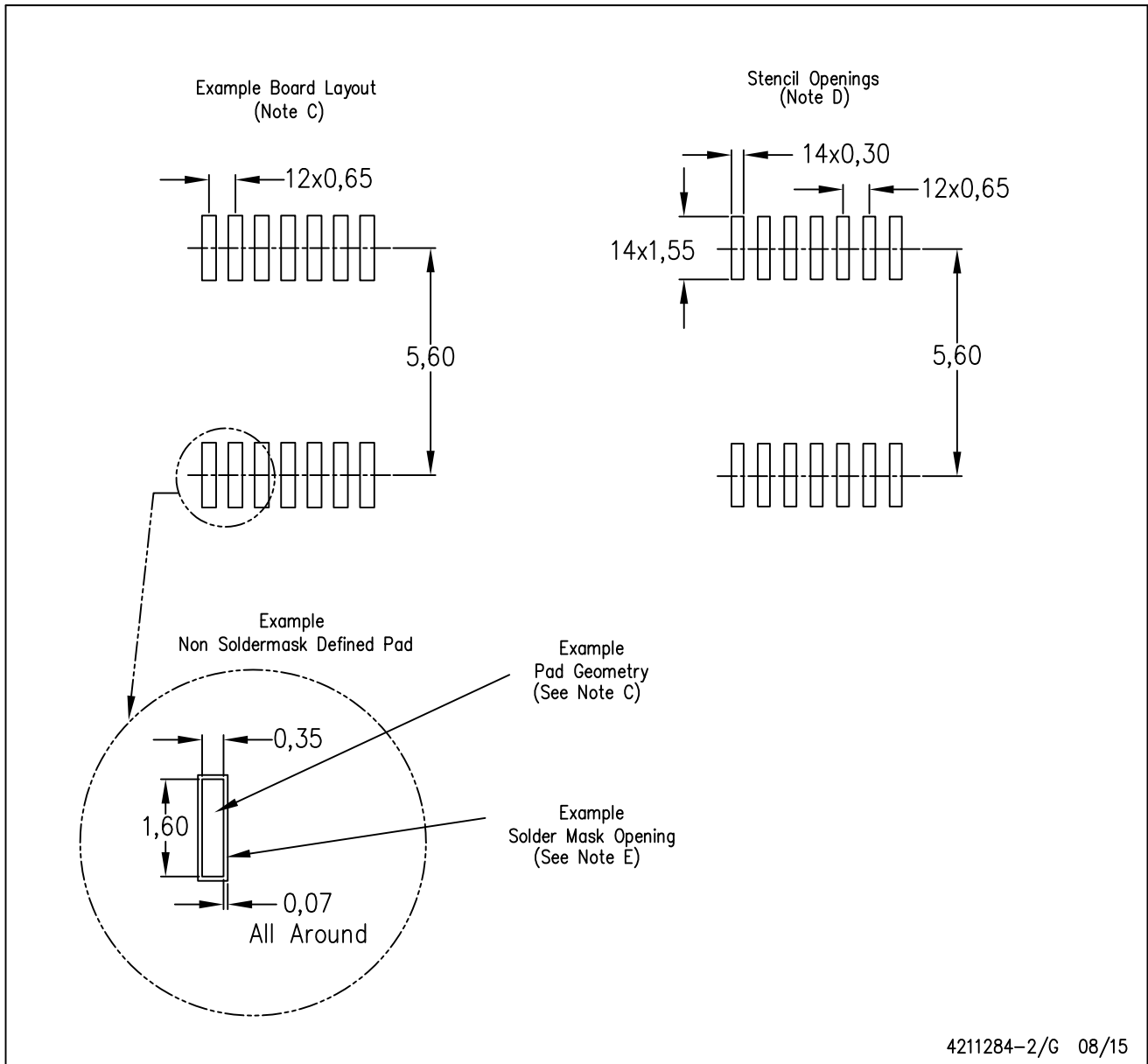

- NOTES:
- All linear dimensions are in millimeters.
 - This drawing is subject to change without notice.
 - Publication IPC-7351 is recommended for alternate designs.
 - Laser cutting apertures with trapezoidal walls and also rounding corners will offer better paste release. Customers should contact their board assembly site for stencil design recommendations. Refer to IPC-7525 for other stencil recommendations.
 - Customers should contact their board fabrication site for solder mask tolerances between and around signal pads.

IMPORTANT NOTICE AND DISCLAIMER

TI PROVIDES TECHNICAL AND RELIABILITY DATA (INCLUDING DATA SHEETS), DESIGN RESOURCES (INCLUDING REFERENCE DESIGNS), APPLICATION OR OTHER DESIGN ADVICE, WEB TOOLS, SAFETY INFORMATION, AND OTHER RESOURCES "AS IS" AND WITH ALL FAULTS, AND DISCLAIMS ALL WARRANTIES, EXPRESS AND IMPLIED, INCLUDING WITHOUT LIMITATION ANY IMPLIED WARRANTIES OF MERCHANTABILITY, FITNESS FOR A PARTICULAR PURPOSE OR NON-INFRINGEMENT OF THIRD PARTY INTELLECTUAL PROPERTY RIGHTS.

These resources are intended for skilled developers designing with TI products. You are solely responsible for (1) selecting the appropriate TI products for your application, (2) designing, validating and testing your application, and (3) ensuring your application meets applicable standards, and any other safety, security, regulatory or other requirements.

These resources are subject to change without notice. TI grants you permission to use these resources only for development of an application that uses the TI products described in the resource. Other reproduction and display of these resources is prohibited. No license is granted to any other TI intellectual property right or to any third party intellectual property right. TI disclaims responsibility for, and you will fully indemnify TI and its representatives against, any claims, damages, costs, losses, and liabilities arising out of your use of these resources.

TI's products are provided subject to [TI's Terms of Sale](#) or other applicable terms available either on ti.com or provided in conjunction with such TI products. TI's provision of these resources does not expand or otherwise alter TI's applicable warranties or warranty disclaimers for TI products.

TI objects to and rejects any additional or different terms you may have proposed.

Mailing Address: Texas Instruments, Post Office Box 655303, Dallas, Texas 75265
Copyright © 2022, Texas Instruments Incorporated