

Multi-sensor predictive maintenance kit with IO-Link stack v.1.1



Features

- Kit content:
 - Sensor node (marked STEVAL-IDP005V2; not available for separate sale)
 - Communication adapter board (marked STEVAL-UKI001V2; not available for separate sale)
 - [STLINK-V3MINI](#) programming and debugging interface
 - Cables and connector
- Main supply voltage: 18 - 32 V
- Main components of the sensor node:
 - 32-bit ARM® Cortex®-M4 core for signal processing and analysis ([STM32F469AI](#))
 - Ultra-wide bandwidth (up to 6kHz), low-noise, 3-axis digital vibration sensor ([IIS3DWB](#))
 - Absolute digital pressure sensor ([LPS22HB](#))
 - Relative humidity and temperature sensors ([HTS221](#))
 - Digital microphone sensors ([IMP34DT05](#))
 - IO-Link PHY device ([L6362A](#))
 - EEPROM ([M95M01-DF](#)) for data storage
 - Step-down switching regulator and LDO regulator ([L6984](#) and [LDK220](#))
 - ESD protection ([ESDALC6V1-1U2](#), [SMBJ33CA](#))
- Complete set of firmware demo examples based on 3D accelerometer library with advanced frequency and time domain signal processing for predictive maintenance, including:
 - Programmable FFT size (256, 512, 1024, 2048), overlapping and averaging
 - Programmable windowing (Flat Top, Hanning, Hamming, Rectangular)
 - Speed RMS moving average, acceleration max. peak
 - Programmable threshold for warning and alarm conditions in spectral band
- Microphone algorithms for:
 - PDM to PCM
 - Sound pressure level (SPL)
 - Audio FFT
- IO-Link device stack v1.1 protocol and IO-Link Device Descriptor (IODD) for all measurements included (provided by TEConcept GmbH)
- M12 standard industrial connector
- SWD connector for debugging and programming capability
- Reset button
- Expansion connector with GPIO, ADC, I²C bus, timer
- Designed to meet IEC industrial standard requirements

Product summary	
Multi sensor predictive maintenance kit with embedded IO-Link stack v.1.1	STEVAL-BFA001V2B
High-performance advanced line, ARM Cortex-M4 core with DSP and FPU, 2 Mbytes Flash, 384+4 kB of RAM, DMA controller, up to 17 timers	STM32F469AI
Ultra-wide bandwidth, low-noise 3-axis digital accelerometer for industrial applications	IIS3DWB
IO-Link communication transceiver device	L6362A
Compact in-circuit debugger and programmer for STM32	STLINK-V3MINI
Software package for STEVAL-BFA001V2B evaluation kit	STSW-BFA001V2

Description

The [STEVAL-BFA001V2B](#) is an industrial reference design kit for condition monitoring (CM) and predictive maintenance (PdM), in a layout that is designed to meet IEC61000-4-2/4 and EN60947 requirements for industrial applications.

Product summary	
Applications	Condition monitoring and predictive maintenance Smart industry

The hardware consists of a highly compact (50 x 9 x 9 mm) industrial sensor board specifically designed for real industrial applications, and the necessary debugging tools, cables, plugs and adapters for an industrial communications scenario. The connection is managed using a standard multipolar cable with one wire used for IO-Link data.

The [STSW-BFA001V2](#) firmware package (freely available on www.st.com) includes dedicated algorithms for advanced time and frequency domain signal processing and analysis of the high bandwidth 3D digital accelerometer for vibration monitoring. The package includes pressure, relative humidity and temperature sensor monitoring samples as well as audio algorithms for acoustic emission (AE).

The firmware runs on the high performance [STM32F469AI](#), ARM® Cortex®-M4, 32-bit microcontroller. The sensor data analysis results can be displayed on a user PC terminal emulator via wired connectivity or the related IO-Link master board interface.

IO-Link device stack v1.1. (for evaluation purposes, with some limitations) is included in object library format with IO-Link Device Descriptor (IODD) for all measurements and with dedicated examples to demonstrate device interoperability with any master tool. It supports BLOB transfer for vibration and acoustic FFT data, event generator and parameter configuration.

The package includes a GUI to demonstrate the IO-Link device features when connected to the [STEWAL-IDP004V2](#) multi-port master evaluation board.

1 Solution overview

1.1 Block diagram

The STEVAL-BFA001V2B kit enables predictive maintenance (early detection of failures on the equipment under monitoring), managing key parameters coming from environmental, vibration and acoustic sensors. It is suitable for monitoring motors, pumps and fans, and can accelerate the development of predictive maintenance solutions and PoCs.

The kit performs advanced time and frequency domain signal processing for vibration analysis, running on embedded high performance MCU with configurable thresholds for alarms and warnings, demonstrating the process at edge level.

The tiny and compact form factor has been designed to allow placement of the sensor node very close to the equipment to be monitored.

The power management phase generates the low voltage needed for digital sensors and MCU from an industrial 18 to 32 V input voltage range.

The IO-Link device stack protocol is included with the STSW-BFA001V2 dedicated firmware to demonstrate the IO-Link device features.

Figure 1. STEVAL-BFA001V2B main board (sensor node) block diagram

The sensor node is marked STEVAL-IDP005V2; it is not available for separate sale

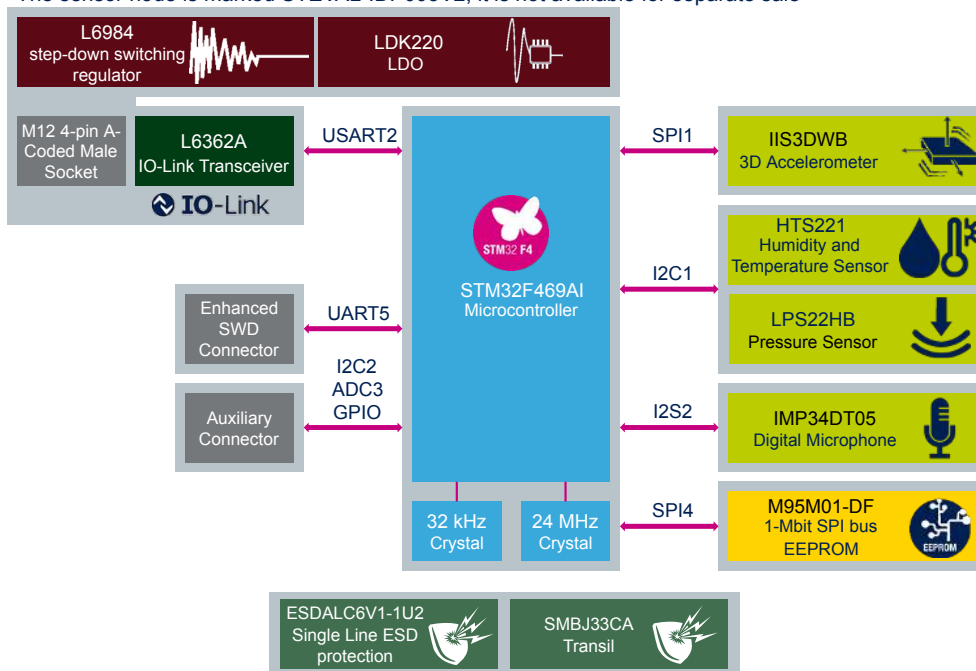

1.2 Schematic diagrams

Figure 2. STEVAL-UKI001V2 (adapter board) circuit schematic

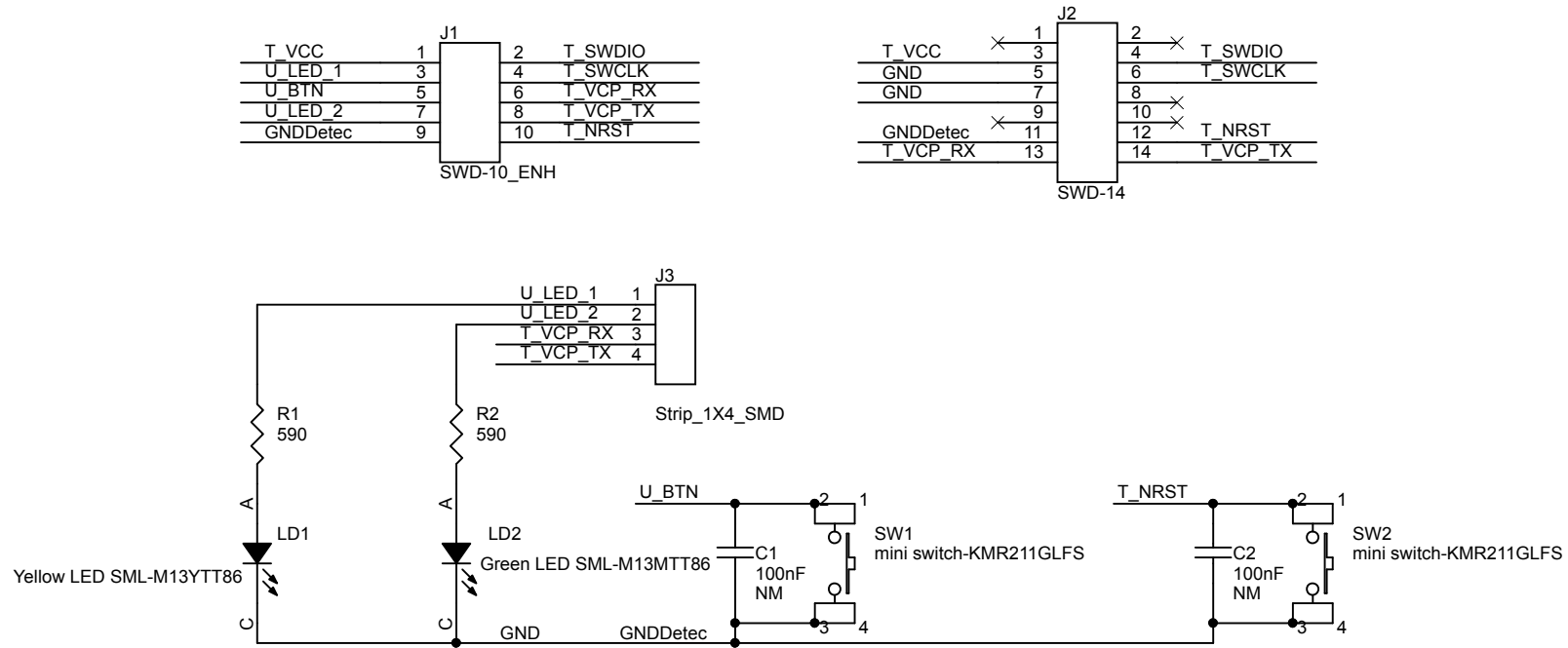

Figure 3. STEVAL-IDP005V2 (main board) circuit schematic

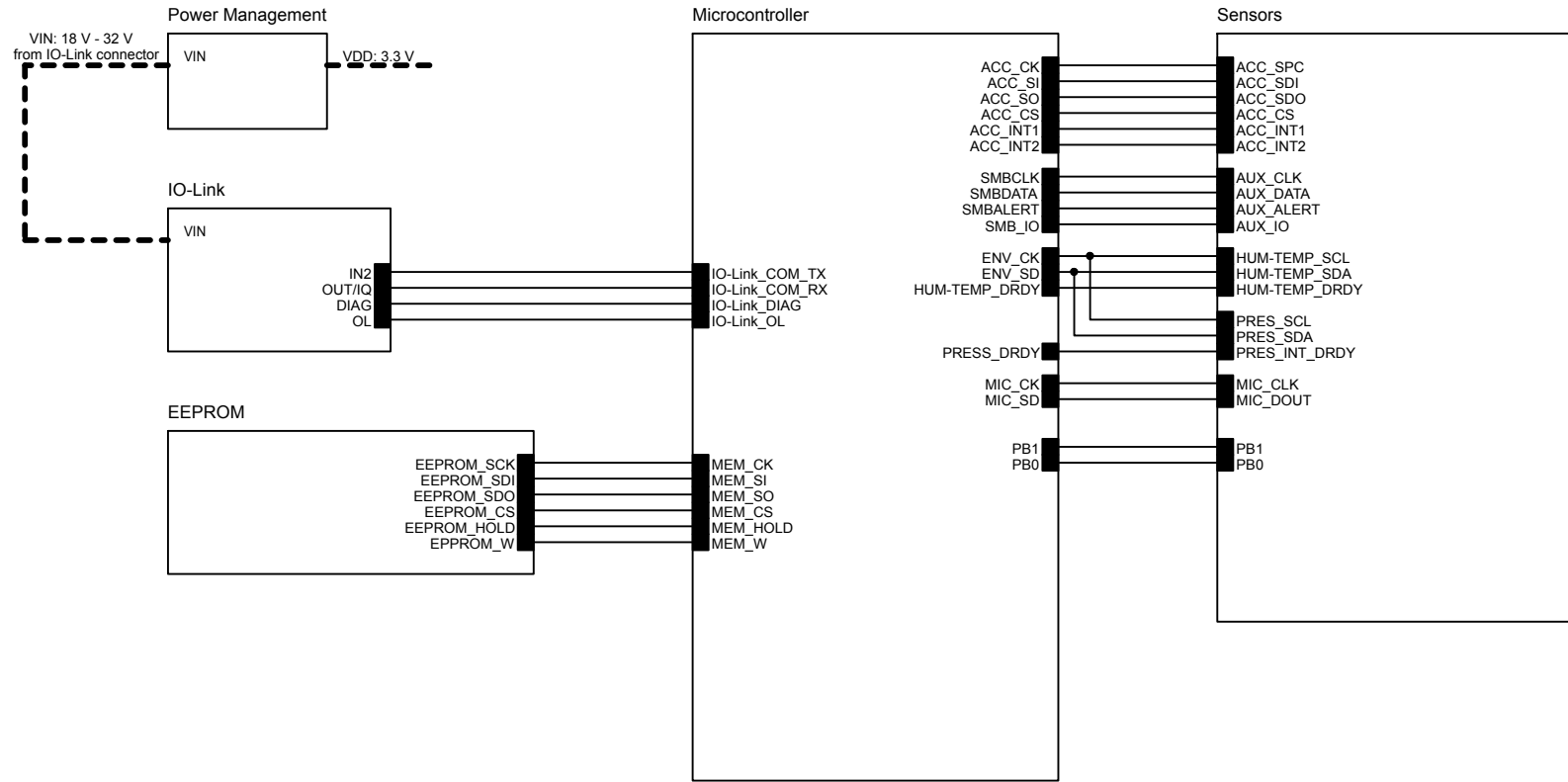

Figure 4. STEVAL-IDP005V2 (main board) circuit schematic - power management

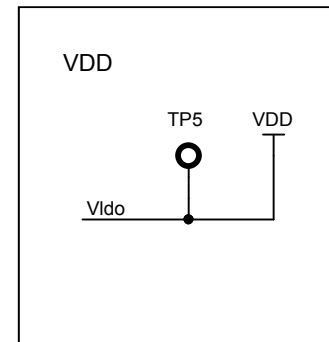
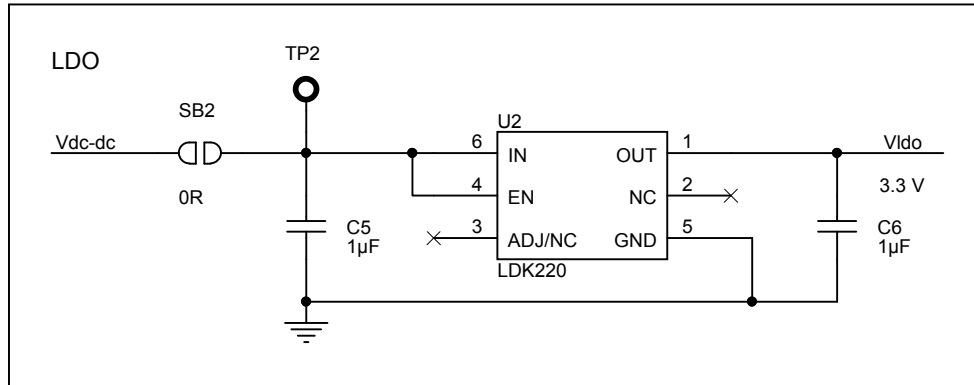
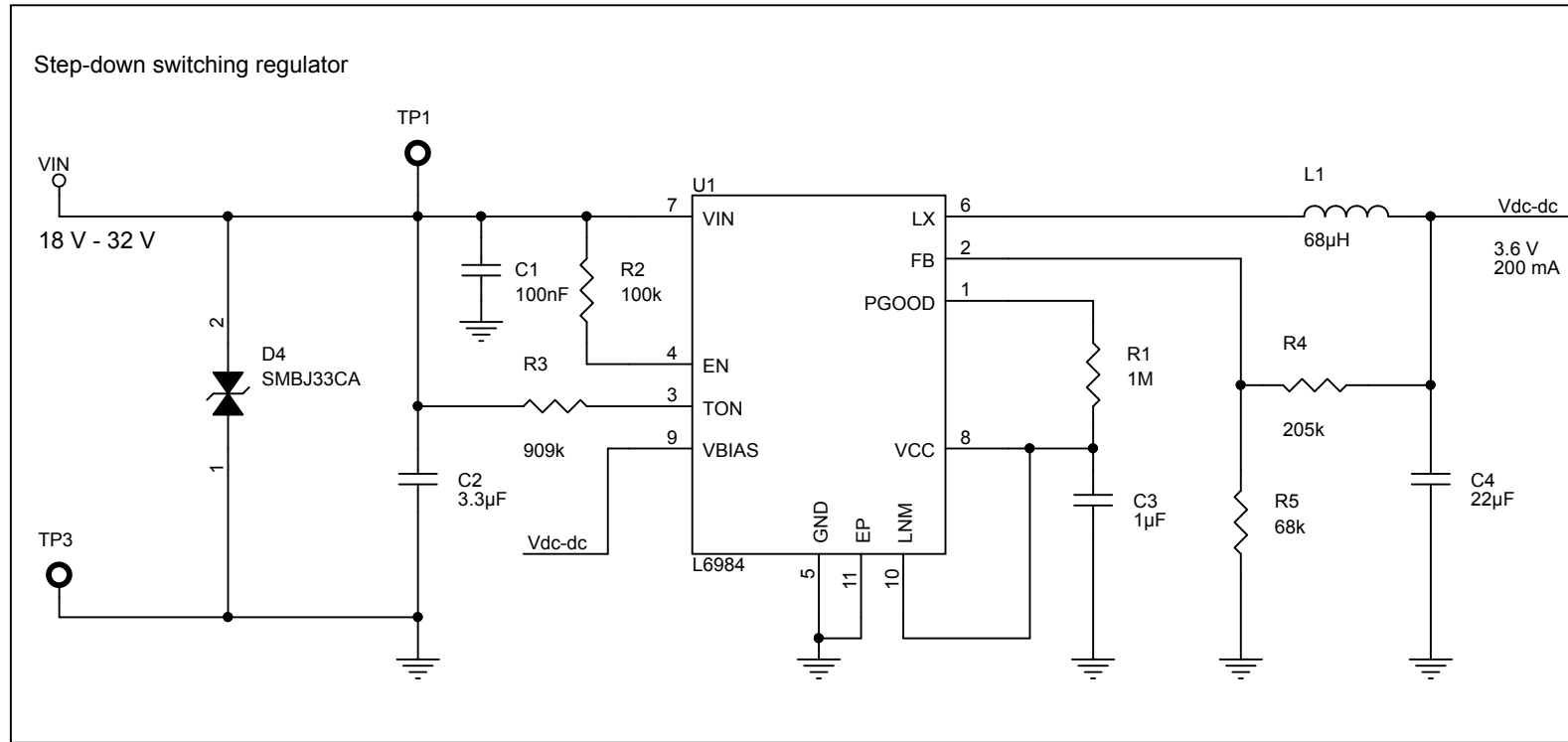

Figure 5. STEVAL-IDP005V2 (main board) circuit schematic - IO-Link

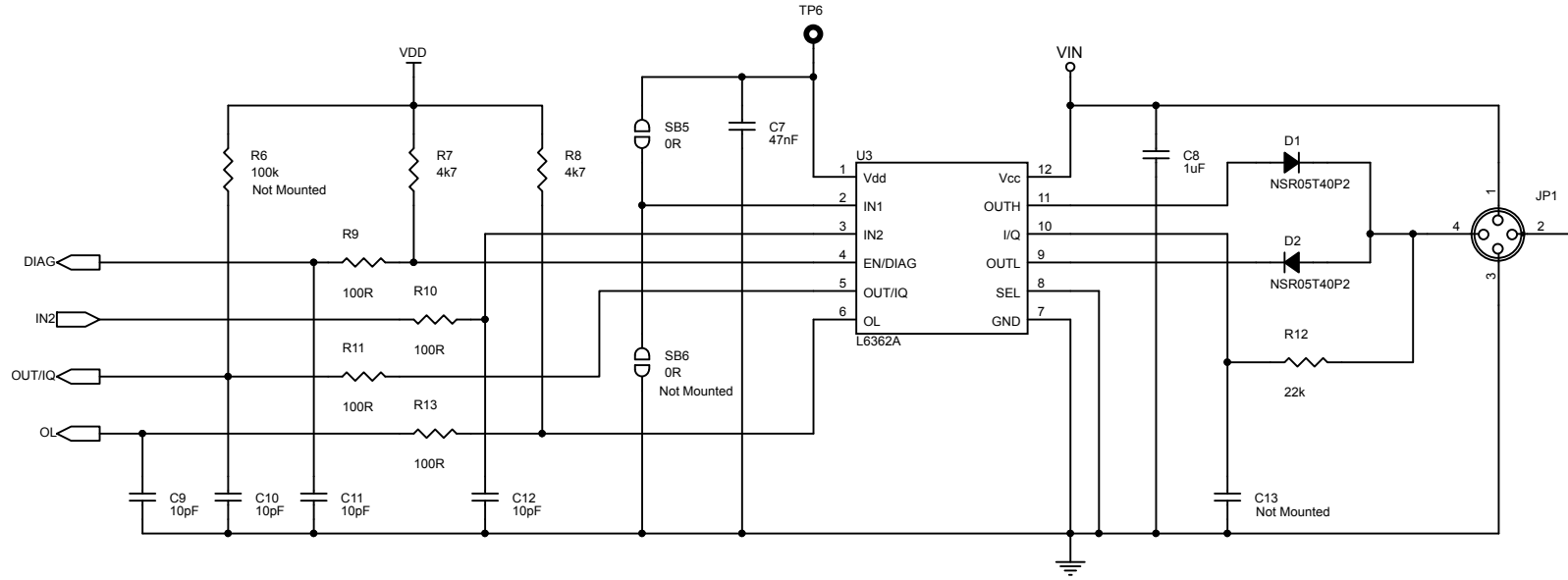

Figure 6. STEVAL-IDP005V2 (main board) circuit schematic - sensors

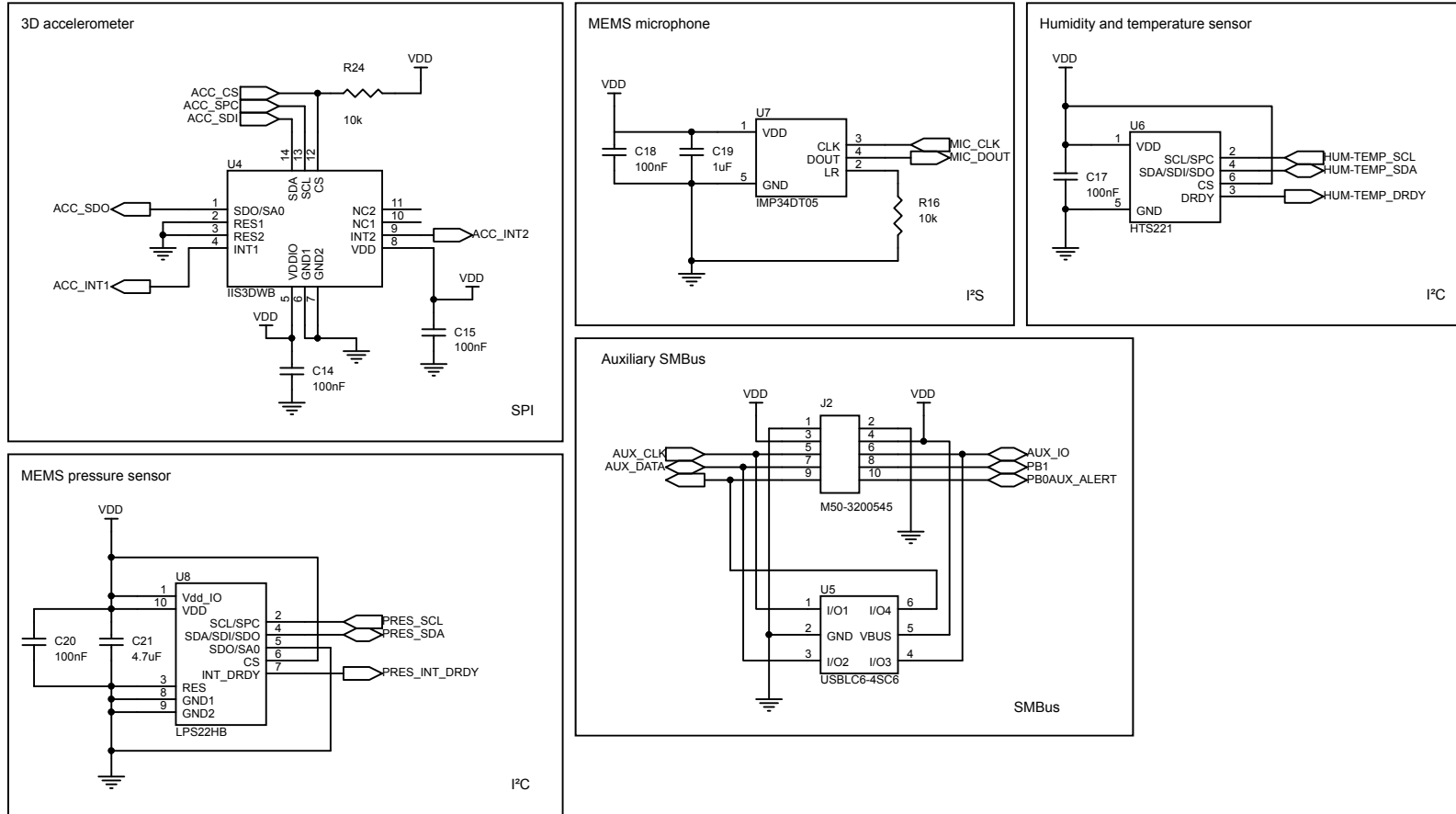

Figure 7. STEVAL-IDP005V2 (main board) circuit schematic - EEPROM

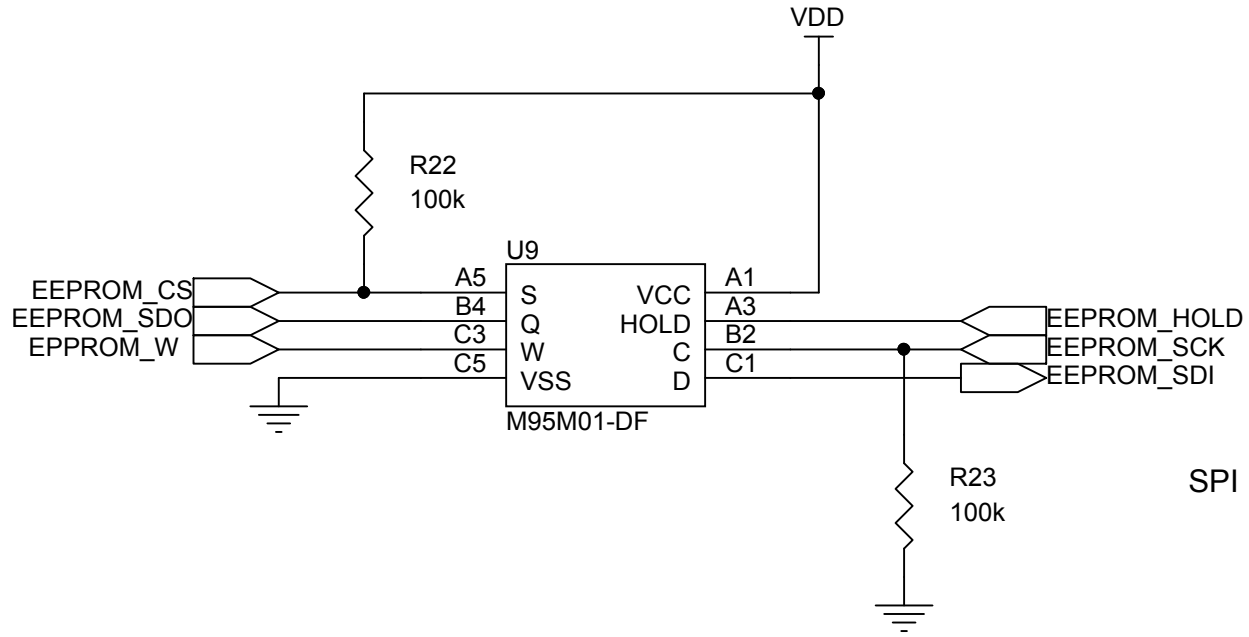

Figure 8. STEVAL-IDP005V2 (main board) circuit schematic - microcontroller (1 of 2)

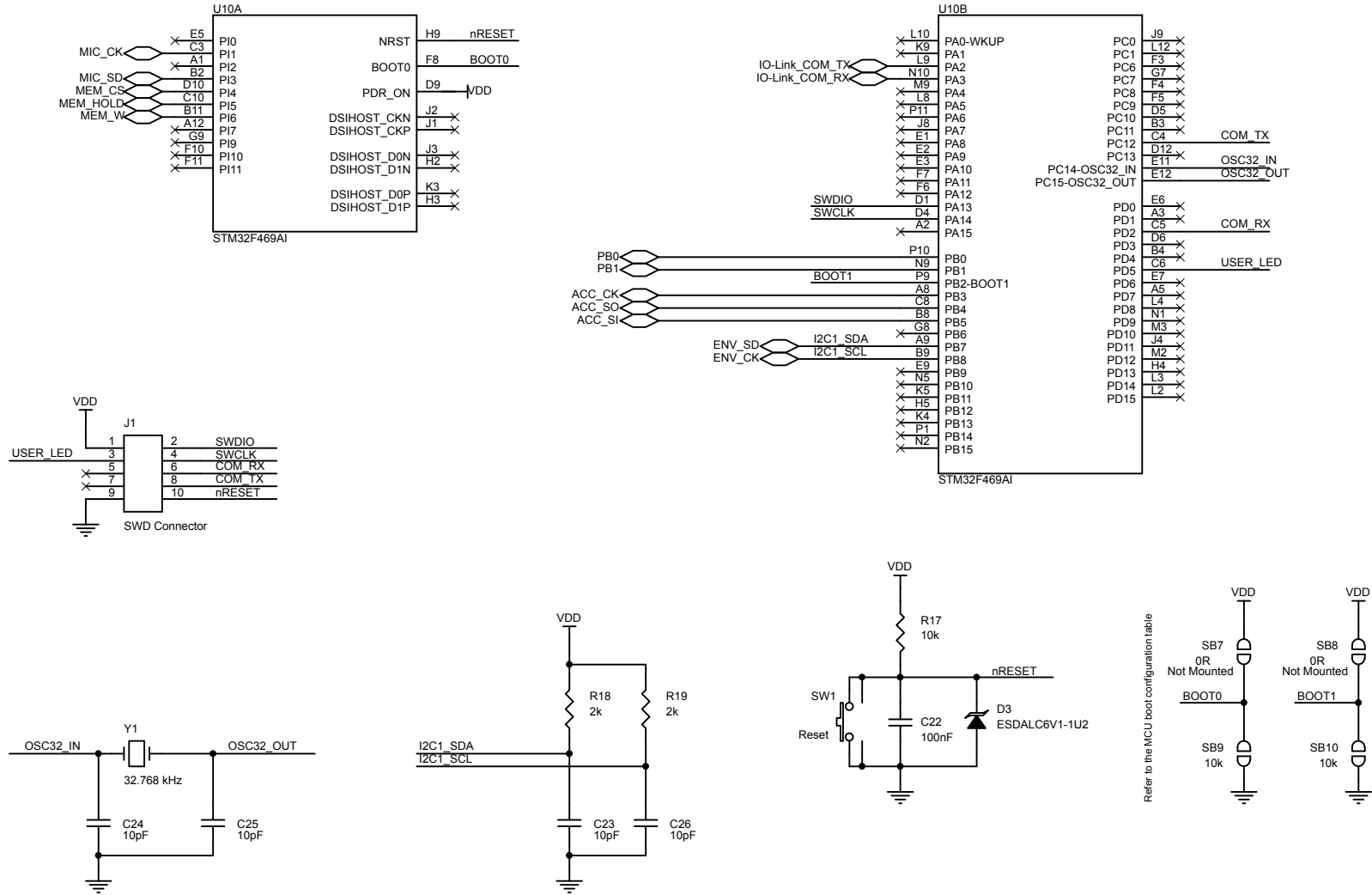
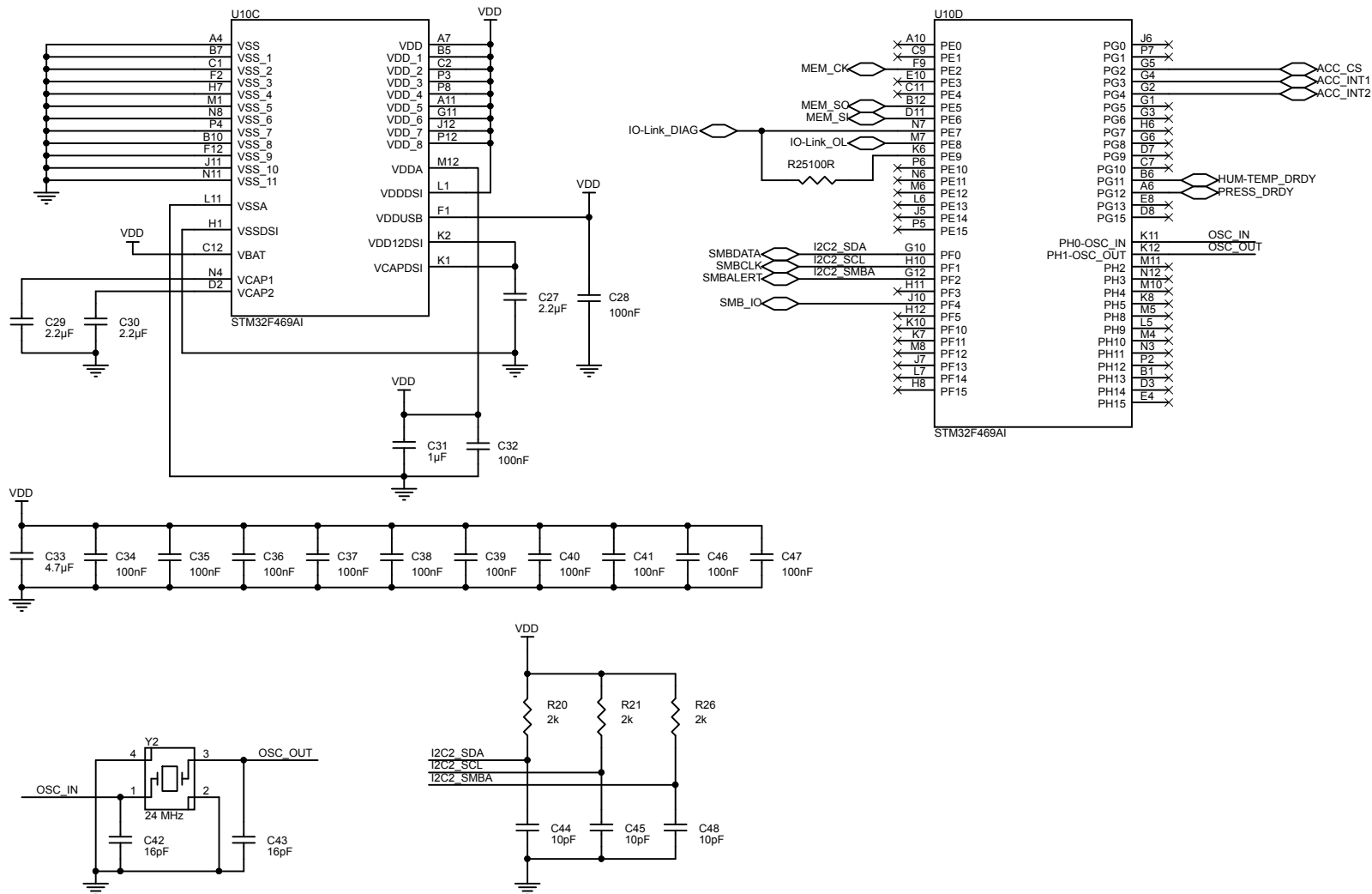

Figure 9. STEVAL-IDP005V2 (main board) circuit schematic - microcontroller (2 of 2)



Revision history

Table 1. Document revision history

Date	Version	Changes
20-Nov-2019	1	Initial release.
27-Apr-2020	2	Updated cover page features. Added Figure 7. STEVAL-IDP005V2 (main board) circuit schematic - EEPROM.

IMPORTANT NOTICE – PLEASE READ CAREFULLY

STMicroelectronics NV and its subsidiaries (“ST”) reserve the right to make changes, corrections, enhancements, modifications, and improvements to ST products and/or to this document at any time without notice. Purchasers should obtain the latest relevant information on ST products before placing orders. ST products are sold pursuant to ST’s terms and conditions of sale in place at the time of order acknowledgement.

Purchasers are solely responsible for the choice, selection, and use of ST products and ST assumes no liability for application assistance or the design of Purchasers’ products.

No license, express or implied, to any intellectual property right is granted by ST herein.

Resale of ST products with provisions different from the information set forth herein shall void any warranty granted by ST for such product.

ST and the ST logo are trademarks of ST. For additional information about ST trademarks, please refer to www.st.com/trademarks. All other product or service names are the property of their respective owners.

Information in this document supersedes and replaces information previously supplied in any prior versions of this document.

© 2020 STMicroelectronics – All rights reserved