

Two Output PCIe Gen1/2/3/4 Clock Generator

Features

- Complies with PCIe Gen1/2/3/4 Common Clock Spec
- Integrated MEMS Resonator Eliminates the Need for External 25 MHz Crystal
- 100 MHz HCSL/LVDS/LVCMOS Options Available
- Wide Temperature Range:
 - Ext. Industrial: -40°C to $+105^{\circ}\text{C}$
 - Industrial: -40°C to $+85^{\circ}\text{C}$
 - Commercial: -20°C to $+70^{\circ}\text{C}$
- Supply Range of 2.25V to 3.6V
- Low Power Consumption
 - 30% Lower than Competing Devices
- Excellent Shock & Vibration Immunity
 - Qualified to MIL-STD-883
- Space Saving 14-Lead QFN Package
- Lead-Free and RoHS-Compliant

Applications

- Communications/Networking
 - Ethernet
 - 1G, 10GBASE-T/KR/LR/SR, and FcoE
 - Routers and Switches
 - Gateways, VoIP, Wireless AP's
 - Passive Optical Networks
- Storage
 - SAN, NAS, SSD, JBOD
- Embedded Applications
 - Industrial, Medical, and Avionics
 - Security Systems and Office Automation
 - Digital Signage, POS and others
- Consumer Electronics
 - Smart TV, Bluray, STB

General Description

The DSC557-03 is a two output PCI express clock generator meeting Gen1, Gen2, Gen3 and Gen 4 specifications. The clock generator uses proven silicon MEMS technology to provide 100 MHz* differential output clocks with excellent jitter and stability over a wide range of supply voltages and temperatures. By eliminating the external quartz crystal, the DSC557-03 significantly enhances reliability and accelerates product development, while meeting stringent clock performance criteria for a variety of communications, storage, and networking applications.

DSC557-03 has an Output Enable / Disable feature allowing it to disable the outputs when OE is low. The device is available in a space saving 14 pin QFN. Additional output formats are also available in any combination of LVCMOS, LVDS, and HCSL.

Block Diagram

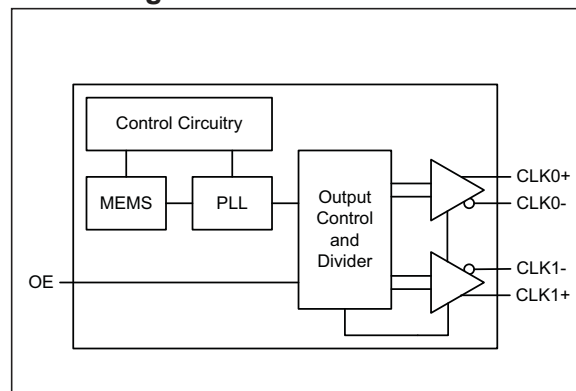

DSC557-03

Package Type

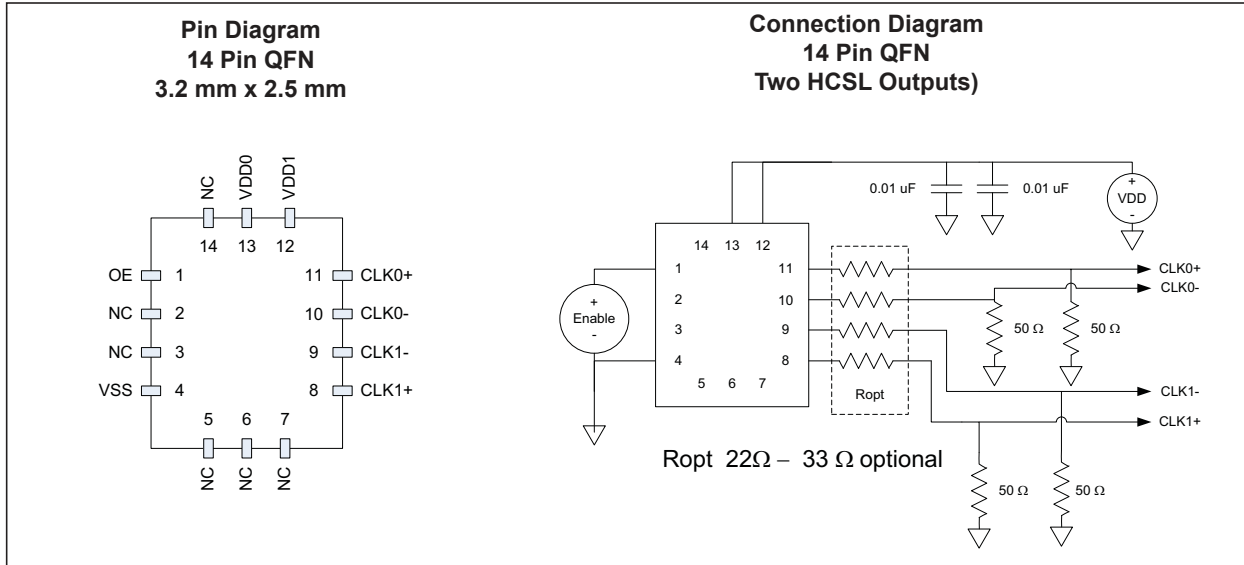

TABLE 0-1: PIN DESCRIPTION (14 QFN)

Pin Number	Pin Name	Pin Type	Description
1	OE	I	Output Enable; Active-high.
2	NC	N/A	Ground recommended or leave as a NC.
3	NC	N/A	Ground recommended or leave as a NC.
4	VSS	Power	Ground.
5	NC	N/A	Ground recommended or leave as a NC.
6	NC	N/A	Ground recommended or leave as a NC.
7	NC	N/A	Ground recommended or leave as a NC.
8	CLK1+	O	True output of differential pair.
9	CLK1-	O	Complement output of differential pair.
10	CLK0-	O	Complement output of differential pair.
11	CLK0+	O	True output of differential pair.
12	VDD1	Power	Power Supply for Output 1 (CLK1+/-).
13	VDD0	Power	Power Supply for Core and Output 0 (CLK0+/-).
14	NC	N/A	Ground recommended or leave as a NC.
ePAD	ePAD	N/A	Thermal pad, floating, not DC connected to substrate ground.

1.0 ELECTRICAL CHARACTERISTICS

Absolute Maximum Ratings †

Supply Voltage	-0.3V to +4.0V
Input Voltage	-0.3V to $V_{DD} + 0.3V$
ESD Protection (HBM)4 kV
ESD Protection (MM)	400V
ESD Protection (CDM)	1.5 kV

† **Notice:** Stresses above those listed under “Absolute Maximum Ratings” may cause permanent damage to the device. This is a stress rating only and functional operation of the device at those or any other conditions above those indicated in the operational sections of this specification is not intended. Exposure to maximum rating conditions for extended periods may affect device reliability.

ELECTRICAL CHARACTERISTICS

Electrical Characteristics: $V_{DD} = 3.3V$; $T = 25^{\circ}C$, unless specified otherwise.

Parameter	Symbol	Min.	Typ.	Max.	Units	Conditions
Supply Voltage	V_{DD}	2.25	—	3.6	V	Note 1
Supply Current	I_{DD}	—	—	—	—	EN pin low - outputs are disabled
Supply Current (Two HCSL Outputs), Note 2	I_{DD}	—	60	—	mA	EN pin high - outputs are enabled $R_L = 50\Omega$, $F_{O1} = F_{O2} = 100$ MHz
Frequency Stability	Δf	—	—	± 100	ppm	Includes frequency variations due to initial tolerance, temp. and power supply voltage
		—	—	± 50		
Startup Time	t_{SU}	—	—	5	ms	Note 3
Input Logic Levels,	V_{IH}	$0.7 \times V_{DD}$	—	—	V	Input logic high
	V_{IL}	—	—	$0.3 \times V_{DD}$		Input logic low
Output Disable Time	t_{DA}	—	—	5	ns	Note 4
Output Enable Time	t_{EN}	—	—	20	ns	—
Pull-Up Resistor	—	—	40	—	k Ω	Pull-up on OE pin
HCSL Outputs						
Output Logic Levels						
Output Logic High	V_{OH}	0.725	—	—	V	$R_L = 50\Omega$
Output Logic Low	V_{OL}	—	—	0.1	V	
Peak to Peak Output Swing	—	—	750	—	mV	Single-ended
Output Transition Time						
Rise Time	t_R	200	—	400	ps	20% to 80%, $R_L = 50\Omega$, $C_L = 2$ pF
Fall Time	t_F	200	—	400		
Frequency	f_0	—	100	—	MHz	Single frequency
Output Duty Cycle	SYM	48	—	52	%	Differential
Period Jitter Note 5	J_{PER}	—	2.5	—	pSRMS	$F_{O1} = F_{O2} = 100$ MHz

DSC557-03

ELECTRICAL CHARACTERISTICS (CONTINUED)

Electrical Characteristics: $V_{DD} = 3.3V$; $T = 25^{\circ}C$, unless specified otherwise.

Parameter	Symbol	Min.	Typ.	Max.	Units	Conditions
Jitter, Phase (Common Clock Architecture) Note 6	T_J	—	17	86	ps_{PP}	PCIe Gen 1.1 $T_J = D_J + 14.069 \times R_J$ (BER 10^{-12})
	$J_{RMS-CCHF}$	—	1.46	3.1	ps_{RMS}	PCIe Gen 2.1, 1.5 MHz to Nyquist
	$J_{RMS-CCLF}$	—	0.08	3.0	ps_{RMS}	PCIe Gen 2.1, 10 kHz to 1.5 MHz
	J_{RMS-CC}	—	0.313	1.0	ps_{RMS}	PCIe Gen 3.0
—		0.313	0.5	ps_{RMS}	PCIe Gen 4.0	
Integrated Phase Noise (Data Clock Architecture) Note 6	$J_{RMS-DCHF}$	—	2.15	—	ps_{RMS}	PCIe Gen 2.1, 1.5 MHz to Nyquist
	$J_{RMS-CCLF}$	—	0.06	—	ps_{RMS}	PCIe Gen 2.1, 10 kHz to 1.5 MHz
	J_{RMS-DC}	—	0.32	—	ps_{RMS}	PCIe Gen 3.0
LVDS Output						
Offset Voltage	V_{OS}	1.125	1.25	1.40	V	$V_{DD} = 2.5V/3.3V$
V_{OS} Magnitude Change	ΔV_{OS}	—	—	50	mV	—
Output High Voltage	V_{OH}	$0.9 \times V_{DD}$	—	—	V	—
Output Low Voltage	V_{OL}	—	—	$0.1 \times V_{DD}$	V	—
Output Frequency	f_{OUT}	—	100	—	MHz	—
Differential Output Voltage	V_{OD}	275	350	475	mV_{PP}	—
V_{OD} Magnitude Change	ΔV_{OD}	—	—	40	mV	—
LVDS Output Rise/Fall Time	t_r/t_f	—	200	—	ps	20% – 80%
Output Duty Cycle	ODC	48	50	52	%	20% – 80%, $R_L = 50\Omega$, $C_L = 2$ pF
Period Jitter, Peak to Peak	J_{PTP}	—	2.5	—	ps	$f_{OUT} = 100$ MHz, Standard Drive
Integrated Phase Noise	J_{PH}	—	0.28	—	ps_{RMS}	200 kHz to 20 MHz @ 100 MHz, $T_A = +105^{\circ}C$
		—	0.4	—		100 kHz to 80 MHz @ 100 MHz
		—	1.7	2.0		12 kHz to 10 MHz @ 100 MHz
LVC MOS Output						
Output High Voltage	V_{OH}	$0.8 \times V_{DD}$	—	—	V	± 10 mA drive current
Output Low Voltage	V_{OL}	—	—	$0.2 \times V_{DD}$	V	± 10 mA drive current
Output Frequency	f_{OUT}	—	100	—	MHz	—
Output Rise/Fall Time	t_r/t_f	—	1.2	—	ns	20% – 80%, $C_L = 15$ pF
Output Duty Cycle	ODC	48	50	52	%	$f_{OUT} = 100$ MHz, Standard Drive
Period Jitter	J_{PTP}	—	3	—	ps_{RMS}	$f_{OUT} = 100$ MHz, Standard Drive
Integrated Phase Noise	J_{PH}	—	0.3	—	ps_{RMS}	200 kHz to 20 MHz @ 100 MHz
		—	0.38	—		100 kHz to 20 MHz @ 100 MHz
		—	1.7	2.0		12 kHz to 20 MHz @ 100 MHz

- Note 1:** V_{DD} pin should be filtered with a 0.1 μF capacitor.
Note 2: Output is enabled if OE pin is floated or not connected.
Note 3: t_{su} is time to 100 PPM stable output frequency after V_{DD} is applied and outputs are enabled.
Note 4: Output Waveform and Connection Diagram define the parameters.
Note 5: Period Jitter includes crosstalk from adjacent output.
Note 6: Jitter limits established by Gen 1.1, Gen 2.1, Gen 3.0 and Gen 4.0 PCIe standards.

TEMPERATURE SPECIFICATIONS (Note 1)

Parameters	Symbol	Min.	Typ.	Max.	Units	Conditions
Temperature Ranges						
Junction Operating Temperature	T_J	—	—	+150	°C	—
Storage Temperature Range	T_S	-55	—	+150	°C	—
Lead Temperature	—	—	+260	—	°C	Soldering, 40s

Note 1: The maximum allowable power dissipation is a function of ambient temperature, the maximum allowable junction temperature and the thermal resistance from junction to air (i.e., T_A , T_J , θ_{JA}). Exceeding the maximum allowable power dissipation will cause the device operating junction temperature to exceed the maximum +150°C rating. Sustained junction temperatures above +150°C can impact the device reliability.

3.0 SOLDER REFLOW PROFILE

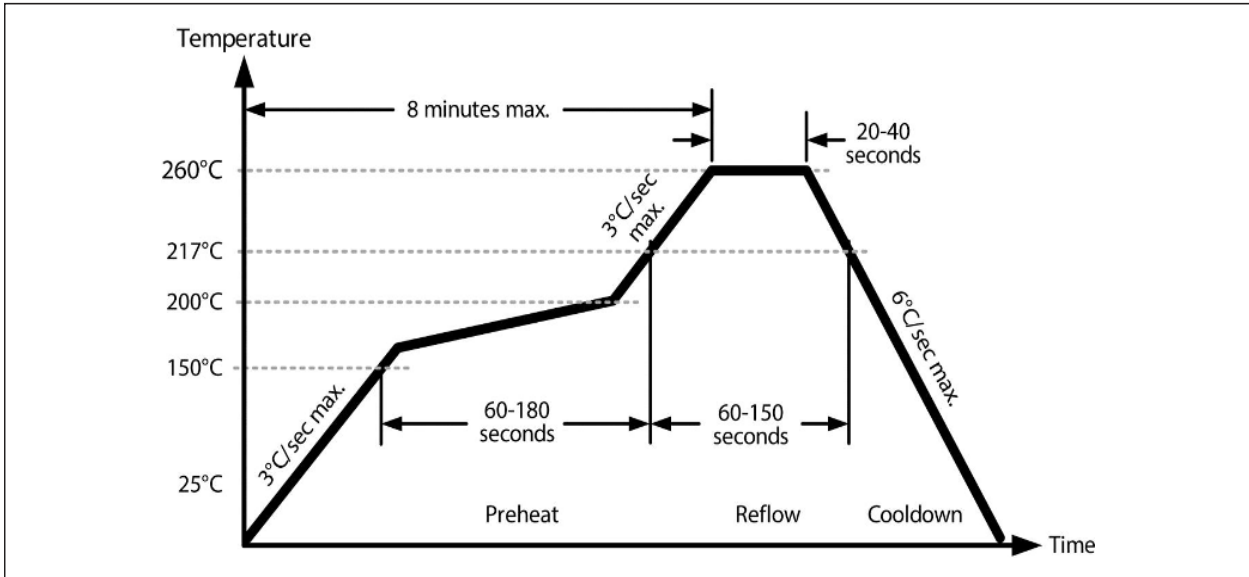

FIGURE 3-1: Solder Reflow Profile.

TABLE 3-1: SOLDER REFLOW

14 QFN MSL 1 @ 260°C refer to JSTD-020C	
Ramp-Up Rate (200°C to Peak Temp.)	3°C/sec. max.
Preheat Time 150°C to 200°C	60 to 180 sec.
Time Maintained above 217°C	60 to 150 sec.
Peak Temperature	255°C to 260°C
Time within 5°C of Actual Peak	20 to 40 sec.
Ramp-Down Rate	6°C/sec. max.
Time 25°C to Peak Temperature	8 minutes max.

DSC557-03

4.0 PACKAGING INFORMATION

4.1 Package Marking Information

14-Lead QFN*
(2.5 mm x 3.2 mm)

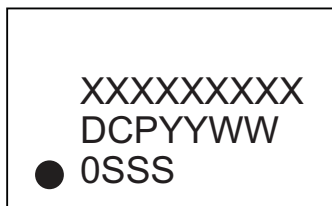

Example



Legend:	XX...X	Product code or customer-specific information
	Y	Year code (last digit of calendar year)
	YY	Year code (last 2 digits of calendar year)
	WW	Week code (week of January 1 is week '01')
	NNN	Alphanumeric traceability code
	(e3)	Pb-free JEDEC® designator for Matte Tin (Sn)
	*	This package is Pb-free. The Pb-free JEDEC designator ((e3)) can be found on the outer packaging for this package.
	●, ▲, ▼	Pin one index is identified by a dot, delta up, or delta down (triangle mark).
Note:	In the event the full Microchip part number cannot be marked on one line, it will be carried over to the next line, thus limiting the number of available characters for customer-specific information. Package may or may not include the corporate logo.	
	Underbar () and/or Overbar () symbol may not be to scale.	

14-Lead QFN Package Outline and Recommended Land Pattern

TITLE

14 LEAD QFN 2.5x3.2mm PACKAGE OUTLINE & RECOMMENDED LAND PATTERN

DRAWING #	QFN2532-14LD-PL-1	UNIT	MM
------------------	-------------------	-------------	----

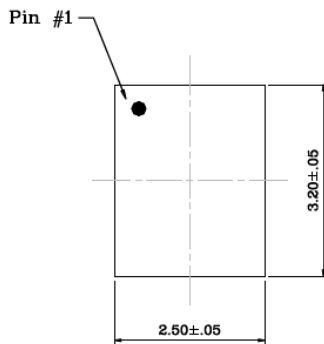

Top View

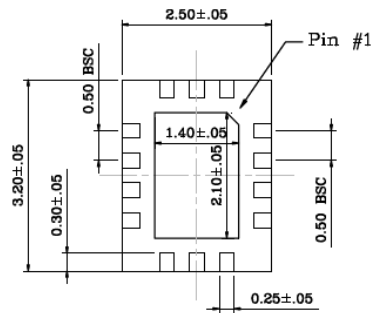

Bottom View



Side View

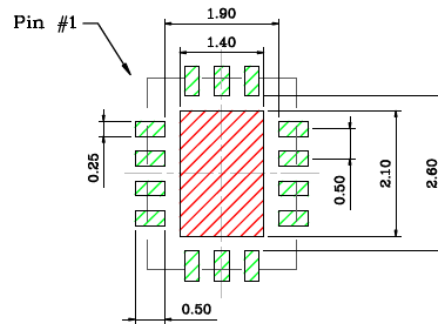

Recommended Land Pattern

NOTE:

1. Green shaded rectangles in Recommended Land Pattern are solder stencil opening.
2. Red shaded rectangle in Recommended Land Pattern is keep out area.

Note: For the most current package drawings, please see the Microchip Packaging Specification located at <http://www.microchip.com/packaging>.

DSC557-03

NOTES:

APPENDIX A: REVISION HISTORY

Revision A (June 2020)

- Conversion of Discera Data Sheet DSC557-03 as Microchip data sheet DS20006318A.
- Added LVDS section to the **Section 1.0 “Electrical Characteristics”** table.
- Added LVCMOS section to the **Section 1.0 “Electrical Characteristics”** table.

DSC557-03

NOTES:

PRODUCT IDENTIFICATION SYSTEM

To order or obtain information, e.g., on pricing or delivery, contact your local Microchip representative or sales office.

<u>PART NO.</u>	X	X	X	X	X	X
Device	CLK1 Output Format	CLK0 Output Format	Package	Temperature	Frequency Stability	Media Type
Device:	DSC557-03: Two Output PCIe Gen1/2/3/4 Clock Generator					
CLK1 Output Format	1 = LVCMOS					
	3 = LVDS					
	4 = HCSL					
CLK0 Output Format	1 = LVCMOS					
	3 = LVDS					
	4 = HCSL					
Package:	F = 14-Lead 2.5 mm x 3.2 mm QFN					
Temperature:	E = -20°C to +70°C (Commercial)					
	I = -40°C to +85°C (Industrial)					
	L = -40°C to +105°C (Extended Industrial)					
Frequency Stability:	0 = ±100 ppm					
	1 = ±50 ppm					
Media Type:	<blank> = 110/Tube					
	T = 1,000/Reel					
Examples:						
a) DSC557-0313FL0: CLK1 Output LVCMOS, CLK0 Output LVDS, 14-Lead QFN, -40°C to +105°C, ±100 ppm, 110/Tube						
b) DSC557-0344FI0: CLK1 Output HCSL, CLK0 Output HCSL, 14-Lead QFN, -40°C to +85°C, ±100 ppm, 110/Tube						
d) DSC557-0343F: CLK1 Output HCSL, CLK0 Output LVDS, 14-Lead QFN, -20°C to +70°C, ±50 ppm, 1,000Tape/Reel						
e) DSC557-0343FL1T: CLK1 Output HCSL, CLK0 Output LVDS, 14-Lead QFN, 40°C to +105°C, ±50 ppm, 1,000Tape/Reel						
Note 1: Tape and Reel identifier only appears in the catalog part number description. This identifier is used for ordering purposes and is not printed on the device package. Check with your Microchip Sales Office for package availability with the Tape and Reel option.						

DSC557-03

NOTES:

Note the following details of the code protection feature on Microchip devices:

- Microchip products meet the specification contained in their particular Microchip Data Sheet.
- Microchip believes that its family of products is one of the most secure families of its kind on the market today, when used in the intended manner and under normal conditions.
- There are dishonest and possibly illegal methods used to breach the code protection feature. All of these methods, to our knowledge, require using the Microchip products in a manner outside the operating specifications contained in Microchip's Data Sheets. Most likely, the person doing so is engaged in theft of intellectual property.
- Microchip is willing to work with the customer who is concerned about the integrity of their code.
- Neither Microchip nor any other semiconductor manufacturer can guarantee the security of their code. Code protection does not mean that we are guaranteeing the product as “unbreakable.”

Code protection is constantly evolving. We at Microchip are committed to continuously improving the code protection features of our products. Attempts to break Microchip's code protection feature may be a violation of the Digital Millennium Copyright Act. If such acts allow unauthorized access to your software or other copyrighted work, you may have a right to sue for relief under that Act.

Information contained in this publication regarding device applications and the like is provided only for your convenience and may be superseded by updates. It is your responsibility to ensure that your application meets with your specifications. MICROCHIP MAKES NO REPRESENTATIONS OR WARRANTIES OF ANY KIND WHETHER EXPRESS OR IMPLIED, WRITTEN OR ORAL, STATUTORY OR OTHERWISE, RELATED TO THE INFORMATION, INCLUDING BUT NOT LIMITED TO ITS CONDITION, QUALITY, PERFORMANCE, MERCHANTABILITY OR FITNESS FOR PURPOSE. Microchip disclaims all liability arising from this information and its use. Use of Microchip devices in life support and/or safety applications is entirely at the buyer's risk, and the buyer agrees to defend, indemnify and hold harmless Microchip from any and all damages, claims, suits, or expenses resulting from such use. No licenses are conveyed, implicitly or otherwise, under any Microchip intellectual property rights unless otherwise stated.

Trademarks

The Microchip name and logo, the Microchip logo, Adaptec, AnyRate, AVR, AVR logo, AVR Freaks, BesTime, BitCloud, chipKIT, chipKIT logo, CryptoMemory, CryptoRF, dsPIC, FlashFlex, flexPWR, HELDO, IGLOO, JukeBlox, KeeLoq, Klear, LANCheck, LinkMD, maXStylus, maXTouch, MediaLB, megaAVR, Microsemi, Microsemi logo, MOST, MOST logo, MPLAB, OptoLyzer, PackeTime, PIC, picoPower, PICSTART, PIC32 logo, PolarFire, Prochip Designer, QTouch, SAM-BA, SenGenuity, SpyNIC, SST, SST Logo, SuperFlash, Symmetricom, SyncServer, Tachyon, TempTrackr, TimeSource, tinyAVR, UNI/O, Vectron, and XMEGA are registered trademarks of Microchip Technology Incorporated in the U.S.A. and other countries.

APT, ClockWorks, The Embedded Control Solutions Company, EtherSynch, FlashTec, Hyper Speed Control, HyperLight Load, IntelliMOS, Libero, motorBench, mTouch, Powermite 3, Precision Edge, ProASIC, ProASIC Plus, ProASIC Plus logo, Quiet-Wire, SmartFusion, SyncWorld, Temux, TimeCesium, TimeHub, TimePictra, TimeProvider, Vite, WinPath, and ZL are registered trademarks of Microchip Technology Incorporated in the U.S.A.

Adjacent Key Suppression, AKS, Analog-for-the-Digital Age, Any Capacitor, AnyIn, AnyOut, BlueSky, BodyCom, CodeGuard, CryptoAuthentication, CryptoAutomotive, CryptoCompanion, CryptoController, dsPICDEM, dsPICDEM.net, Dynamic Average Matching, DAM, ECAN, EtherGREEN, In-Circuit Serial Programming, ICSP, INICnet, Inter-Chip Connectivity, JitterBlocker, KlearNet, KlearNet logo, memBrain, Mindi, MiWi, MPASM, MPF, MPLAB Certified logo, MPLIB, MPLINK, MultiTRAK, NetDetach, Omniscient Code Generation, PICDEM, PICDEM.net, PICKit, PICtail, PowerSmart, PureSilicon, QMatrix, REAL ICE, Ripple Blocker, SAM-ICE, Serial Quad I/O, SMART-I.S., SQI, SuperSwitcher, SuperSwitcher II, Total Endurance, TSHARC, USBCheck, VariSense, ViewSpan, WiperLock, Wireless DNA, and ZENA are trademarks of Microchip Technology Incorporated in the U.S.A. and other countries.

SQTP is a service mark of Microchip Technology Incorporated in the U.S.A.

The Adaptec logo, Frequency on Demand, Silicon Storage Technology, and Symmcom are registered trademarks of Microchip Technology Inc. in other countries.

GestIC is a registered trademark of Microchip Technology Germany II GmbH & Co. KG, a subsidiary of Microchip Technology Inc., in other countries.

All other trademarks mentioned herein are property of their respective companies.

© 2020, Microchip Technology Incorporated, All Rights Reserved.

ISBN: 978-1-5224-6238-5

For information regarding Microchip's Quality Management Systems, please visit www.microchip.com/quality.



MICROCHIP

Worldwide Sales and Service

AMERICAS

Corporate Office
2355 West Chandler Blvd.
Chandler, AZ 85224-6199
Tel: 480-792-7200
Fax: 480-792-7277
Technical Support:
[http://www.microchip.com/
support](http://www.microchip.com/support)
Web Address:
www.microchip.com

Atlanta
Duluth, GA
Tel: 678-957-9614
Fax: 678-957-1455

Austin, TX
Tel: 512-257-3370

Boston
Westborough, MA
Tel: 774-760-0087
Fax: 774-760-0088

Chicago
Itasca, IL
Tel: 630-285-0071
Fax: 630-285-0075

Dallas
Addison, TX
Tel: 972-818-7423
Fax: 972-818-2924

Detroit
Novi, MI
Tel: 248-848-4000

Houston, TX
Tel: 281-894-5983

Indianapolis
Noblesville, IN
Tel: 317-773-8323
Fax: 317-773-5453
Tel: 317-536-2380

Los Angeles
Mission Viejo, CA
Tel: 949-462-9523
Fax: 949-462-9608
Tel: 951-273-7800

Raleigh, NC
Tel: 919-844-7510

New York, NY
Tel: 631-435-6000

San Jose, CA
Tel: 408-735-9110
Tel: 408-436-4270

Canada - Toronto
Tel: 905-695-1980
Fax: 905-695-2078

ASIA/PACIFIC

Australia - Sydney
Tel: 61-2-9868-6733

China - Beijing
Tel: 86-10-8569-7000

China - Chengdu
Tel: 86-28-8665-5511

China - Chongqing
Tel: 86-23-8980-9588

China - Dongguan
Tel: 86-769-8702-9880

China - Guangzhou
Tel: 86-20-8755-8029

China - Hangzhou
Tel: 86-571-8792-8115

China - Hong Kong SAR
Tel: 852-2943-5100

China - Nanjing
Tel: 86-25-8473-2460

China - Qingdao
Tel: 86-532-8502-7355

China - Shanghai
Tel: 86-21-3326-8000

China - Shenyang
Tel: 86-24-2334-2829

China - Shenzhen
Tel: 86-755-8864-2200

China - Suzhou
Tel: 86-186-6233-1526

China - Wuhan
Tel: 86-27-5980-5300

China - Xian
Tel: 86-29-8833-7252

China - Xiamen
Tel: 86-592-2388138

China - Zhuhai
Tel: 86-756-3210040

ASIA/PACIFIC

India - Bangalore
Tel: 91-80-3090-4444

India - New Delhi
Tel: 91-11-4160-8631

India - Pune
Tel: 91-20-4121-0141

Japan - Osaka
Tel: 81-6-6152-7160

Japan - Tokyo
Tel: 81-3-6880-3770

Korea - Daegu
Tel: 82-53-744-4301

Korea - Seoul
Tel: 82-2-554-7200

Malaysia - Kuala Lumpur
Tel: 60-3-7651-7906

Malaysia - Penang
Tel: 60-4-227-8870

Philippines - Manila
Tel: 63-2-634-9065

Singapore
Tel: 65-6334-8870

Taiwan - Hsin Chu
Tel: 886-3-577-8366

Taiwan - Kaohsiung
Tel: 886-7-213-7830

Taiwan - Taipei
Tel: 886-2-2508-8600

Thailand - Bangkok
Tel: 66-2-694-1351

Vietnam - Ho Chi Minh
Tel: 84-28-5448-2100

EUROPE

Austria - Wels
Tel: 43-7242-2244-39
Fax: 43-7242-2244-393

Denmark - Copenhagen
Tel: 45-4485-5910
Fax: 45-4485-2829

Finland - Espoo
Tel: 358-9-4520-820

France - Paris
Tel: 33-1-69-53-63-20
Fax: 33-1-69-30-90-79

Germany - Garching
Tel: 49-8931-9700

Germany - Haan
Tel: 49-2129-3766400

Germany - Heilbronn
Tel: 49-7131-72400

Germany - Karlsruhe
Tel: 49-721-625370

Germany - Munich
Tel: 49-89-627-144-0
Fax: 49-89-627-144-44

Germany - Rosenheim
Tel: 49-8031-354-560

Israel - Ra'anana
Tel: 972-9-744-7705

Italy - Milan
Tel: 39-0331-742611
Fax: 39-0331-466781

Italy - Padova
Tel: 39-049-7625286

Netherlands - Drunen
Tel: 31-416-690399
Fax: 31-416-690340

Norway - Trondheim
Tel: 47-7288-4388

Poland - Warsaw
Tel: 48-22-3325737

Romania - Bucharest
Tel: 40-21-407-87-50

Spain - Madrid
Tel: 34-91-708-08-90
Fax: 34-91-708-08-91

Sweden - Gothenberg
Tel: 46-31-704-60-40

Sweden - Stockholm
Tel: 46-8-5090-4654

UK - Wokingham
Tel: 44-118-921-5800
Fax: 44-118-921-5820