

THIS DRAWING IS UNPUBLISHED. RELEASED FOR PUBLICATION ,19 .  
 © COPYRIGHT 19 BY AMP INCORPORATED. ALL RIGHTS RESERVED.

LOC	DIST	REVISIONS			
P	LTR	DESCRIPTION	DATE	DWN	APVD
BD	36				
		R	REDRAWN W/O CHANGE PER EC 0020-1343-95	19 MAR 96	-

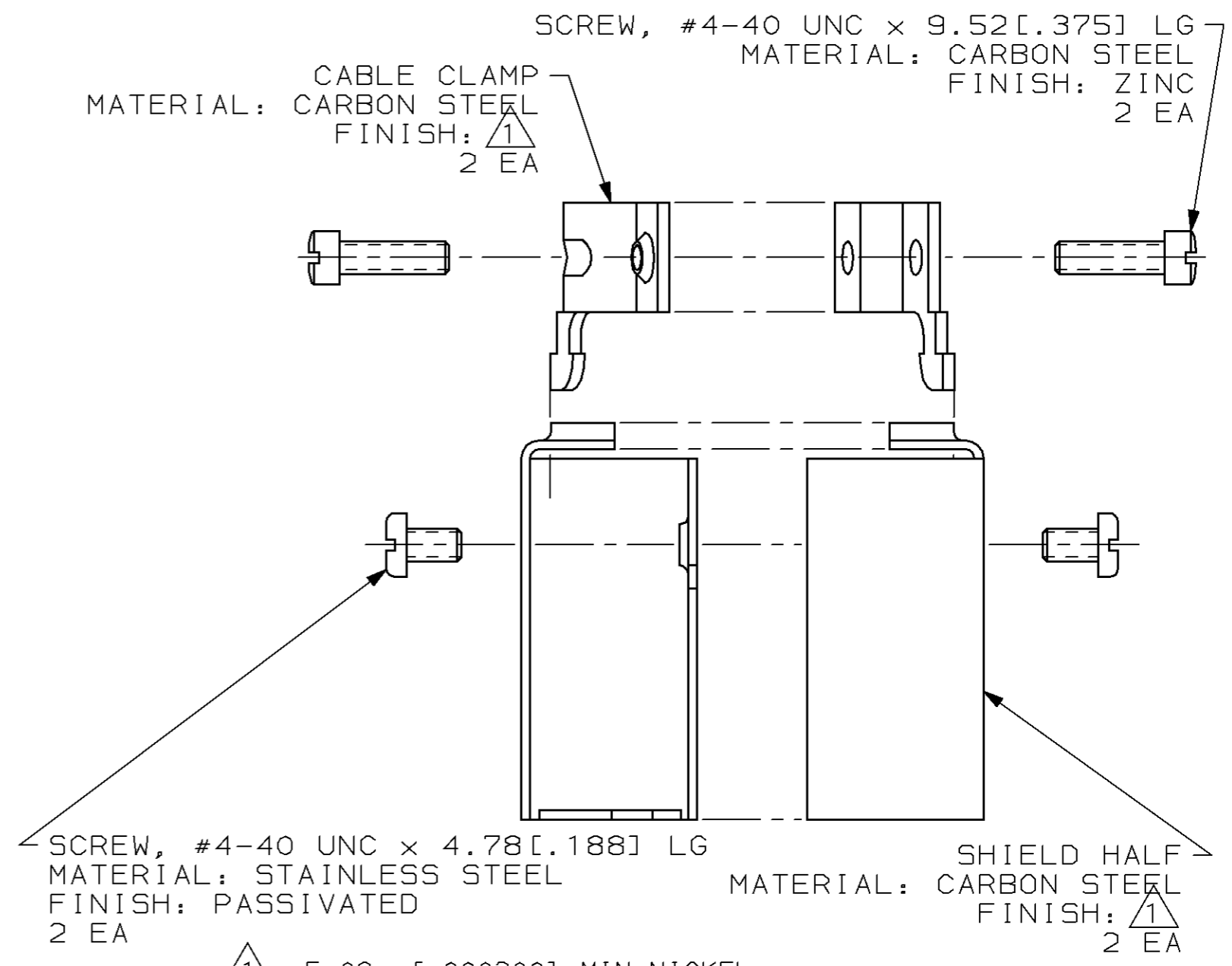
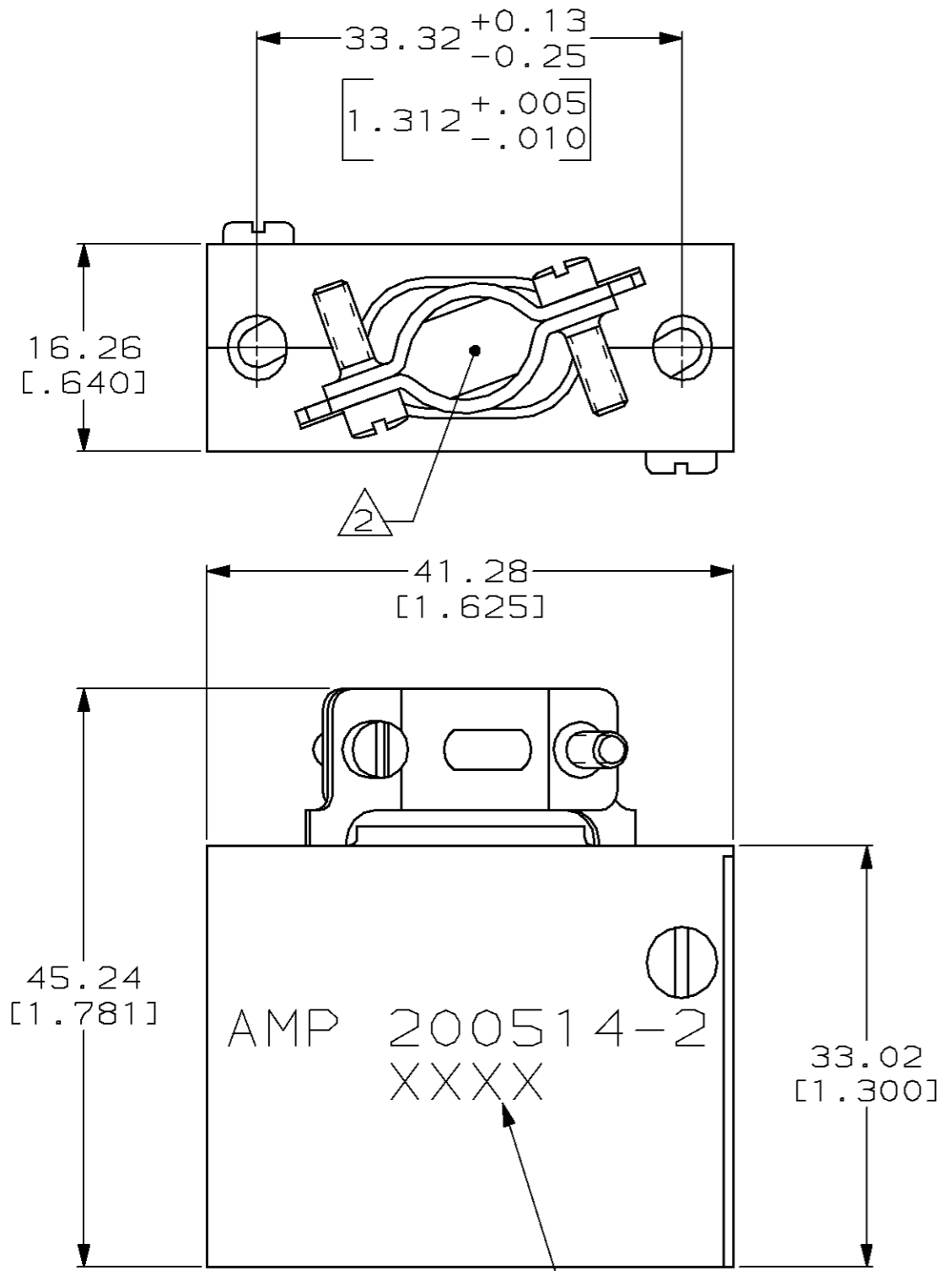

- $\Delta 1$  5.08  $\mu\text{m}$  [.000200] MIN NICKEL.
- $\Delta 2$  CABLE CLAMP WILL ACCEPT 26 WIRES OF  $\phi 1.65$  [.065] MAX.

200514-2  
PART NUMBER

THIS DRAWING IS A CONTROLLED DOCUMENT.		DWN C. REIFSNYDER 19 MAR 96	<b>AMP</b> AMP Incorporated Harrisburg, PA 17105-3608
		CHK R. STONE 02 APR 96	
DIMENSIONS: mm [INCHES]		APVD G. A. STEINHAUER 16 APR 96	NAME SHIELD KIT, UNASSEMBLED, SHORT, 26 PLACE, M SERIES
TOLERANCES UNLESS OTHERWISE SPECIFIED:		PRODUCT SPEC -	
MATERIAL SEE CALLOUTS		APPLICATION SPEC -	SIZE A3
FINISH SEE CALLOUTS		WEIGHT -	CAGE CODE 00779
		CUSTOMER DRAWING	DRAWING NO C-200514
		SCALE 2:1	SHEET 1 OF 1
			REV R