

High Voltage BUCK LED Driver

General Description

The RT8453 is a Buck current mode PWM regulator for LED driving applications. It has a 1.5A switch on board and can be operated with wide input range from 4.5V to 40V. With a 800kHz operating frequency, the external PWM inductor and input/output capacitors can all be small. High efficiency is achieved with a 190mV current sensing. Dimming can be either analog or PWM digital signal driven. The RT8453 is available in SOP8 (Exposed pad) package.

Ordering Information

- RT8453 □ □
 - Package Type
SP : SOP-8 (Exposed Pad-Option 2)
 - Operating Temperature Range
G : Green (Halogen Free with Commercial Standard)

Note :

Richtek Green products are :

- ▶ RoHS compliant and compatible with the current requirements of IPC/JEDEC J-STD-020.
- ▶ Suitable for use in SnPb or Pb-free soldering processes.

Features

- High Voltage : V_{IN} up to 40V
- 1.5A Switch Current
- Current Mode PWM with 800kHz Switching
- Frequency
- Easy Dimming : Analog or Digital method
- Programmable Soft Start to Avoid Inrush Current
- V_{IN} Under Voltage Lockout and Thermal Shutdown
- RoHS Compliant and Halogen Free

Applications

- GPS, Portable DVD Backlight
- Desk Lights and Room Lighting
- Industrial Display Backlight

Pin Configurations

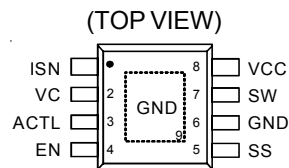

SOP-8 (Exposed Pad)

Typical Application Circuit

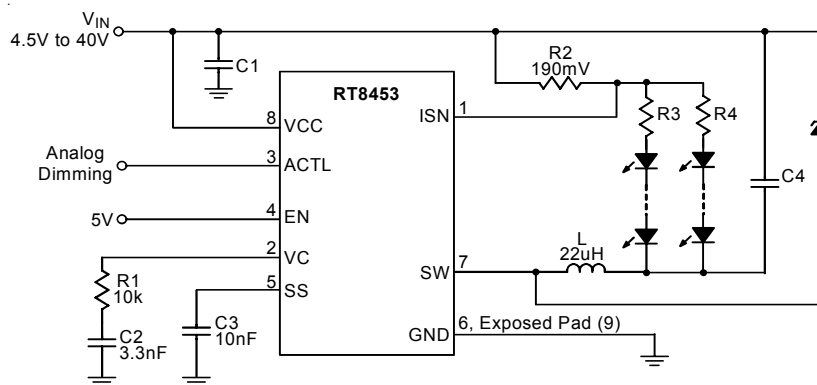

Figure 1. Analog Dimming BUCK Configuration

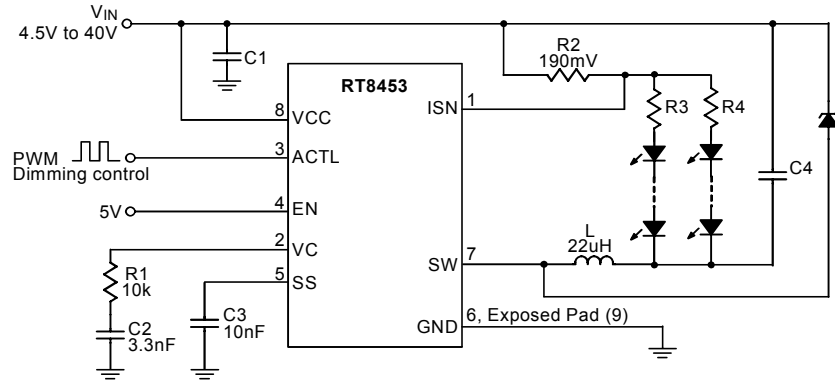

Figure 2. Digital Dimming BUCK Configuration Through ACTL Pin

Functional Pin Description

Pin No.	Pin Name	Pin Function
1	ISN	Current Sense Amplifier Negative Input. Voltage threshold between V_{CC} and ISN is 190mV.
2	VC	PWM Converter Loop Compensation Node.
3	ACTL	Analog Dimming Control. Effective programming range is between 0.3V and 1.2V.
4	EN	Chip Enable (Active High). When low, chip is in shutdown mode.
5	SS	Soft Start. A capacitor of at least 10nF is required for soft start.
6, 9 (Exposed Pad)	GND	Ground. The exposed pad must be soldered to a large PCB and connected to GND for maximum power dissipation.
7	SW	PWM Converter Switch Node.
8	VCC	Power Supply of the Chip. For good bypass, a low ESR capacitor is required.

Function Block Diagram

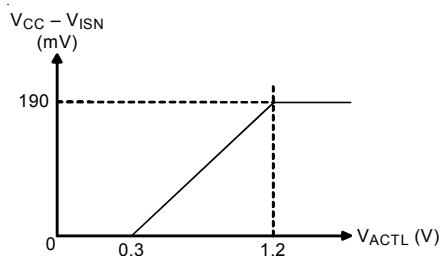
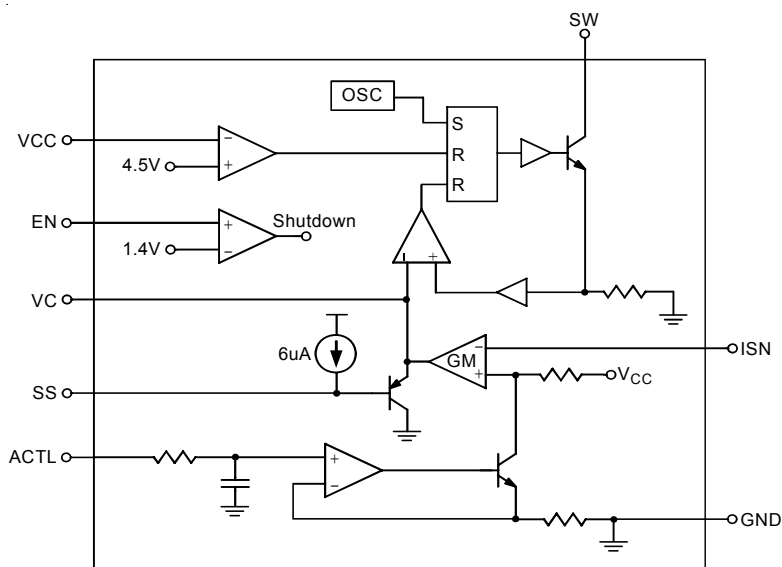

Figure 3

Absolute Maximum Ratings (Note 1)

• Supply Input Voltage, V_{CC} -----	45V
• SW Pin Voltage at Switching Off, ISP, ISN-----	65V
• ACTL-----	8V
• EN, OVP Pin Voltage-----	20V
• Power Dissipation, P_D @ $T_A = 25^\circ\text{C}$	
SOP-8 (Exposed Pad)-----	1.429W
• Package Thermal Resistance (Note 4)	
SOP-8 (Exposed Pad), θ_{JA} -----	75°C/W
SOP-8 (Exposed Pad), θ_{JC} -----	28°C/W
• Junction Temperature-----	150°C
• Lead Temperature (Soldering, 10 sec.)-----	260°C
• Storage Temperature Range-----	-65°C to 150°C
• ESD Susceptibility (Note 2)	
HBM (Human Body Mode)-----	3kV
MM (Machine Mode)-----	250V

Recommended Operating Conditions (Note 3)

• Junction Temperature Range-----	-40°C to 125°C
• Ambient Temperature Range-----	-40°C to 85°C

Electrical Characteristics

($V_{CC} = 12\text{V}$, No Load, $T_A = 25^\circ\text{C}$, unless otherwise specified)

Parameter	Symbol	Conditions	Min	Typ	Max	Unit
Overall						
Supply Voltage	V_{CC}		4.5	--	40	V
Supply Current	I_{VCC}	$V_C \leq 0.4\text{V}$ (Switching off)	--	4	6	mA
Shutdown Current	I_{SHDN}	$V_{EN} \leq 0.7\text{V}$	--	250	--	μA
Shutdown Threshold	V_{EN}		--	1.4	--	V
EN Input Current		$V_{EN} \leq 5\text{V}$	--	--	0.5	μA
Current Sense Amplifier						
Input Threshold ($V_{CC} - V_{ISN}$)		$4.5\text{V} \leq \text{common mode} \leq 60\text{V}$	170	190	210	mV
Input Current	I_{ISN}	$V_{ISN} = 24\text{V}$	--	40	--	μA
Output Current	I_{VC}	$2.4\text{V} > V_C > 0.2\text{V}$	--	± 20	--	μA
VC Threshold for PWM Switch Off			--	0.7	--	V
LED Dimming						
Analog Dimming ACTL Pin Input Current	I_{ACTL}	$0.3\text{V} \leq V_{ACTL} \leq 1.3\text{V}$	--	--	3	μA
LED Current Off Threshold at ACTL	V_{ACTL}		--	0.2	--	V
PWM BOOST Converter						
Switching Frequency	f_{SW}		600k	800k	1M	Hz

To be continued

Parameter	Symbol	Conditions	Min	Typ	Max	Unit
Maximum Duty Cycle (Note 5)			--	86	--	%
SW On-Voltage	V _{SW}	I _{SW} = 0.5A	--	0.4	--	V
SW Current Limit	I _{LIM_SW}		1.25	1.5	--	A
Soft Start						
Soft Start SS Pin Current	I _{SS}	V _{SS} ≤ 2V	--	6	--	μA

Note 1. Stresses beyond those listed under “Absolute Maximum Ratings” may cause permanent damage to the device. These are stress ratings only, and functional operation of the device at these or any other conditions beyond those indicated in the operational sections of the specifications is not implied. Exposure to absolute maximum rating conditions for extended periods may affect device reliability.

Note 2. Devices are ESD sensitive. Handling precaution is recommended.

Note 3. The device is not guaranteed to function outside its operating conditions.

Note 4. θ_{JA} is measured in the natural convection at T_A = 25°C on a high effective four layers thermal conductivity test board of JEDEC 51-7 thermal measurement standard.

Note 5. When the natural maximum duty cycle of 1MHz switching frequency is reached, the switching cycle will be skipped (not reset) as the operating condition requires to effectively stretch and achieve higher on cycle than the natural maximum duty cycle set by the 1MHz switching frequency.

Typical Operating Characteristics

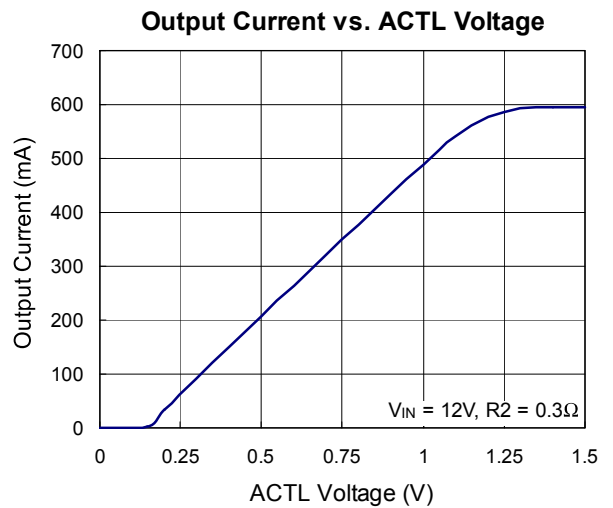
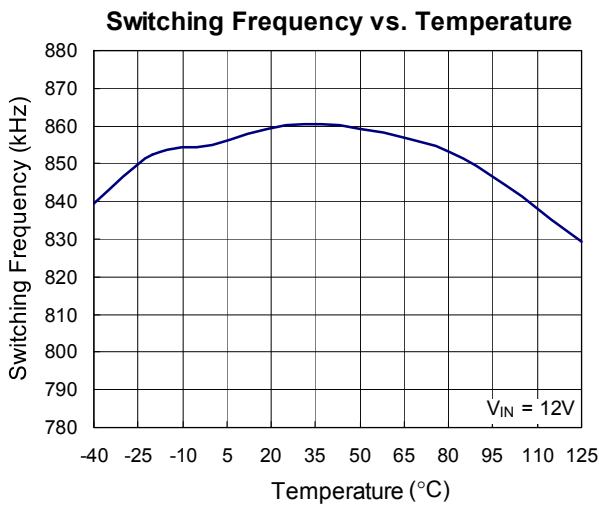
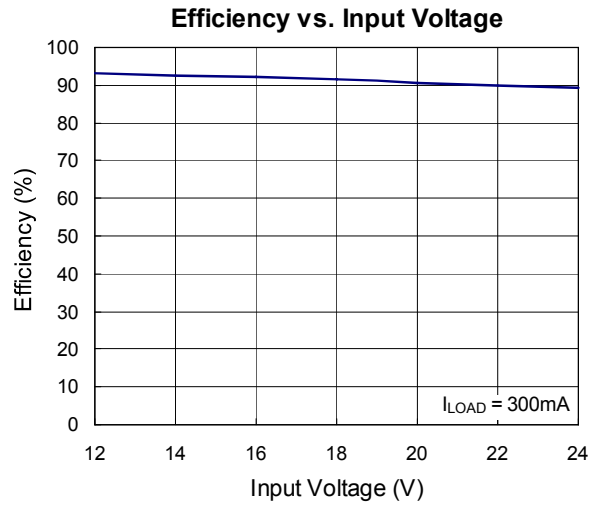
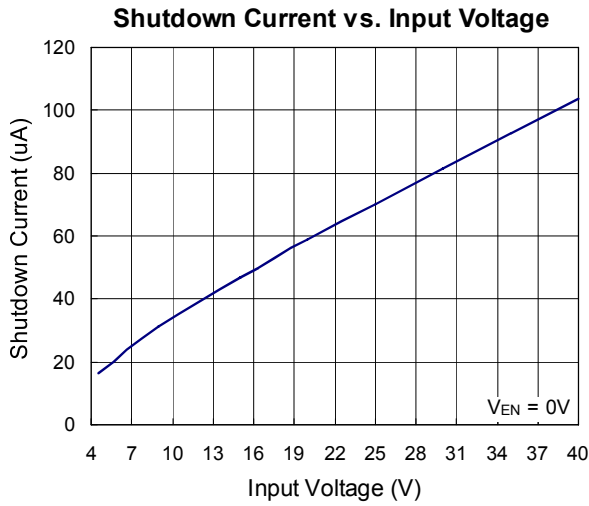
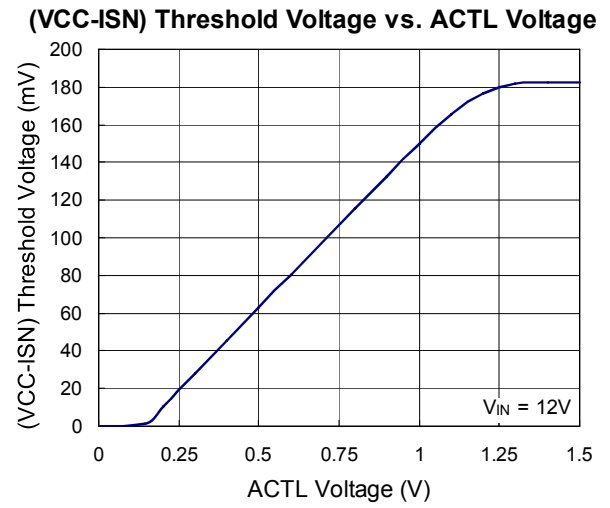
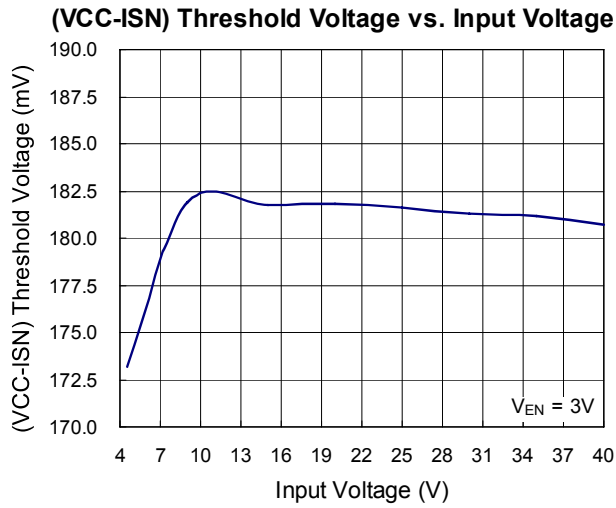

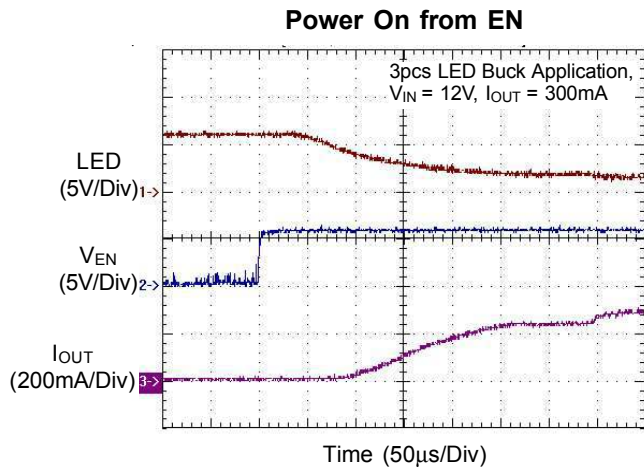
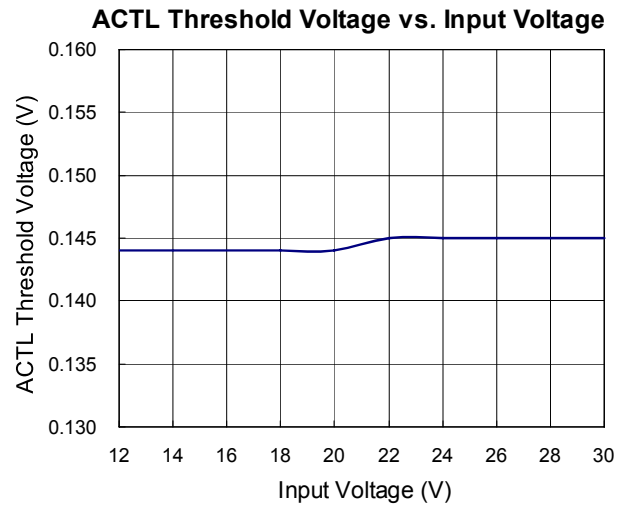
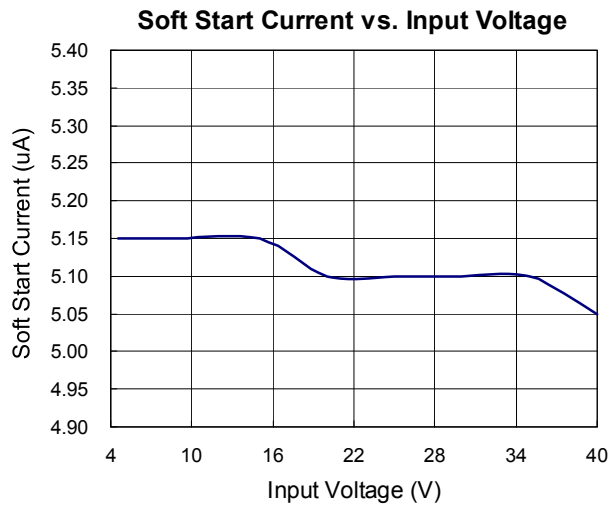

Applications Information

The RT8453 is specifically designed to be operated in buck converter applications. This device uses a fixed frequency, current mode control scheme to provide excellent line and load regulation. The control loop has a current sense amplifier to sense the voltage between the VCC and ISN pins and provides an output voltage at the VC pin. A PWM comparator then turns off the internal power switch when the sensed power switch current exceeds the compensated VC pin voltage. The power switch will not reset by the oscillator clock in each cycle. If the comparator does not turn off the switch in a cycle, the power switch is on for more than a full switching period until the comparator is tripped. In this manner, the programmed voltage across the sense resistor is regulated by the control loop.

The current through the sense resistor is set by the programmed voltage and the sense resistance. The voltage across the sense resistor can be programmed by the analog or digital signal at the ACTL pin.

The protection schemes in RT8453 include over-temperature, and switch current-limit to prevent the abnormal situation.

Frequency Compensation

The RT8453 has an external compensation pin (VC) allowing the loop response optimized for specific application. An external resistor in series with a capacitor is connected from the VC pin to GND to provide a pole and a zero for proper loop compensation. The typical value for RT8453 is 10k and 3.3nF.

Soft Start

The soft-start of RT8453 can be achieved by connecting a capacitor from SS pin to GND.

The built-in soft-start circuit reduces the start-up current spike and output voltage overshoot. The soft-start time is determined by the external capacitor charged by an internal 6uA constant charging current. The SS pin directly limits the rate of voltage rise on the VC pin, which in turn limits the peak switch current.

The value of the soft-start capacitor is user-defined to satisfy the designer's request.

LED current Setting

The LED current can be calculated by the following equation :

$$I_{LED(MAX)} = \frac{V_{CC} - V_{ISN}}{R2}$$

Where,

$V_{CC} - V_{ISN}$ is the voltage between VCC and ISN (190mV typ. if ACTL dimming is not applied) and the R2 is the resistor between VCC and ISN.

Current-Limit Protection

The RT8453 can limit the peak switch current by internal over current protection feature. In normal operation, the power switch is turned off when the switch current hits the loop-set value. The over current protection function will turn off the power switch independent of the loop control when the peak switch current reaches around 1.5A.

Over Temperature Protection

The RT8453 has over temperature protection (OTP) function to prevent the excessive power dissipation from overheating. The OTP function will shut down switching operation when the die junction temperature exceeds 150°C . The chip will automatically start to switch again when the junction temperature cools off .

Inductor Selection

Choose an inductor that can handle the necessary peak current without saturating, and ensure that the inductor has a low DCR (copper-wire resistance) to minimize I²R power losses. A 4.7μH to 22μH inductor will meet the demand of most of the RT8453 applications.

Inductor manufacturers specify the maximum current rating as the current where the inductance falls to certain percentage of its nominal value typically 65%.

In Buck application where the transition between discontinuous and continuous modes occurs, the value of the required output inductor (L), can be approximated by the following equation :

$$L = \left[\frac{V_{OUT}}{f \times \Delta I_L(MAX)} \right] \times \left[1 - \frac{V_{OUT}}{V_{IN(MAX)}} \right]$$

The ripple current ΔI_L could be calculated :

$$\Delta I_L = \left[\frac{V_{OUT}}{f \times L} \right] \times \left[1 - \frac{V_{OUT}}{V_{IN}} \right]$$

Where,

V_{OUT} = output voltage.

V_{IN} = input voltage.

f = switching frequency.

Schottky Diode Selection

The Schottky diode, with their low forward voltage drop and fast switching speed, is necessary for RT8453 applications. In addition, power dissipation, reverse voltage rating and pulsating peak current are the important parameters of the Schottky diode must be considered. The diode's average current rating must exceed the average output current. The diode conducts current only when the power switch is turned off (typically less than 50% duty cycle).

Capacitor Selection

The input capacitor reduces current spikes from the input supply and minimizes noise injection to the converter. For most RT8453 applications, a 4.7 μ F ceramic capacitor is sufficient. A value higher or lower may be used depending on the noise level from the input supply and the input current to the converter.

In Buck Application, the output capacitor is typically a ceramic capacitor and is selected based on the output voltage ripple requirements. The output ripple, ΔV_{OUT} , is determined by the following equation :

$$\Delta V_{OUT} \leq \Delta I_L \times \left[ESR + \frac{1}{8 \times f \times C_{OUT}} \right]$$

Thermal Considerations

For continuous operation, do not exceed absolute maximum operation junction temperature. The maximum power dissipation depends on the thermal resistance of IC package, PCB layout, the rate of surroundings airflow and temperature difference between junction to ambient. The maximum power dissipation can be calculated by following formula :

$$P_{D(MAX)} = (T_{J(MAX)} - T_A) / \theta_{JA}$$

Where $T_{J(MAX)}$ is the maximum operation junction

temperature, T_A is the ambient temperature and the θ_{JA} is the junction to ambient thermal resistance.

For recommended operating conditions specification of RT8453, The maximum junction temperature is 125°C. The junction to ambient thermal resistance θ_{JA} is layout dependent. For SOP-8 (exposed pad) packages, the thermal resistance θ_{JA} is 75°C/W on the standard JEDEC 51-7 four layers thermal test board. The maximum power dissipation at $T_A = 25^\circ\text{C}$ can be calculated by following formula :

$$P_{D(MAX)} = (125^\circ\text{C} - 25^\circ\text{C}) / (75^\circ\text{C/W}) = 1.333\text{W for SOP-8 (exposed pad)}$$

The maximum power dissipation depends on operating ambient temperature for fixed $T_{J(MAX)}$ and thermal resistance θ_{JA} . For RT8453 packages, the Figure 3 of derating curves allows the designer to see the effect of rising ambient temperature on the maximum power dissipation allowed.

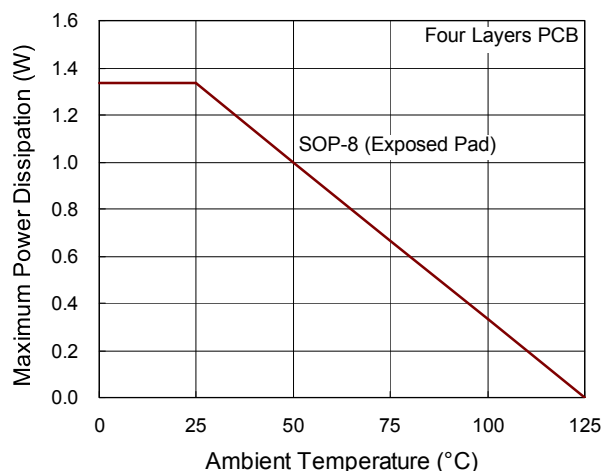

Figure 3. Derating Curves for RT8453 Package

Layout Guideline

PCB layout is very important to design power switching converter circuits. Some recommended layout guide lines are suggested as follows:

- ▶ The power components L1, D1 and C1 must be placed as close to each other as possible to reduce the ac current loop area. The PCB trace between power components must be as short and wide as possible due to large current flow through these traces during operation.

- ▶ Place L1 and D1 connected to SW pin as close as possible. The trace should be as short and wide as possible.
- ▶ The input capacitors C1 must be placed as close to VCC pin as possible.
- ▶ Place the compensation components to VC pin as close as possible to avoid noise pick up.

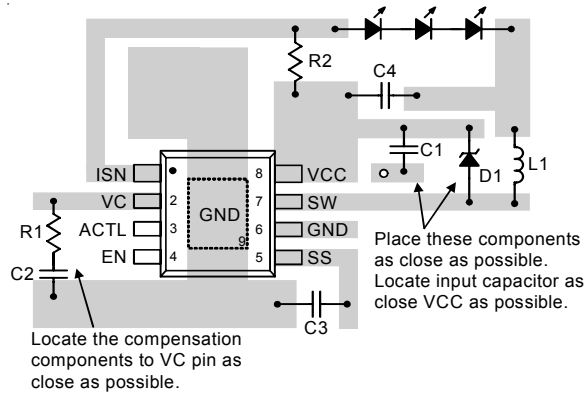
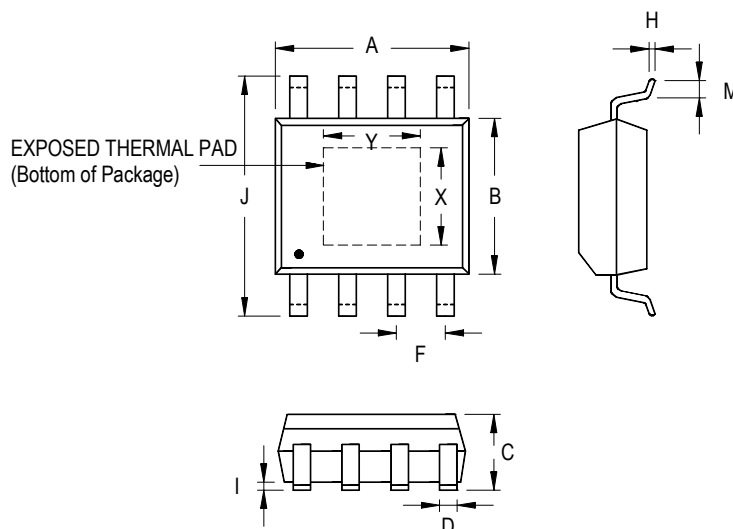

Figure 4

Datasheet Revision History

Version	Data	Page No.	Item	Description
00C	2009/3/18			first edition

Outline Dimension



Symbol	Dimensions In Millimeters		Dimensions In Inches		
	Min	Max	Min	Max	
A	4.801	5.004	0.189	0.197	
B	3.810	4.000	0.150	0.157	
C	1.346	1.753	0.053	0.069	
D	0.330	0.510	0.013	0.020	
F	1.194	1.346	0.047	0.053	
H	0.170	0.254	0.007	0.010	
I	0.000	0.152	0.000	0.006	
J	5.791	6.200	0.228	0.244	
M	0.406	1.270	0.016	0.050	
Option 1	X	2.000	2.300	0.079	0.091
	Y	2.000	2.300	0.079	0.091
Option 2	X	2.100	2.500	0.083	0.098
	Y	3.000	3.500	0.118	0.138

8-Lead SOP (Exposed Pad) Plastic Package

Richtek Technology Corporation

Headquarter

5F, No. 20, Taiyuen Street, Chupei City

Hsinchu, Taiwan, R.O.C.

Tel: (8863)5526789 Fax: (8863)5526611

Richtek Technology Corporation

Taipei Office (Marketing)

8F, No. 137, Lane 235, Paochiao Road, Hsintien City

Taipei County, Taiwan, R.O.C.

Tel: (8862)89191466 Fax: (8862)89191465

Email: marketing@richtek.com

Information that is provided by Richtek Technology Corporation is believed to be accurate and reliable. Richtek reserves the right to make any change in circuit design, specification or other related things if necessary without notice at any time. No third party intellectual property infringement of the applications should be guaranteed by users when integrating Richtek products into any application. No legal responsibility for any said applications is assumed by Richtek.