

THIS DRAWING IS UNPUBLISHED. RELEASED FOR PUBLICATION
 © COPYRIGHT - BY - ALL RIGHTS RESERVED.

REVISIONS					
P	LTR	DESCRIPTION	DATE	DWN	APVD
M		REVISED PER ECO-19-008000	16MAY2019	JY	SH
N		REVISED PER ECO-20-005737	23APR2020	JW	SH

1551920-2 AS SHOWN

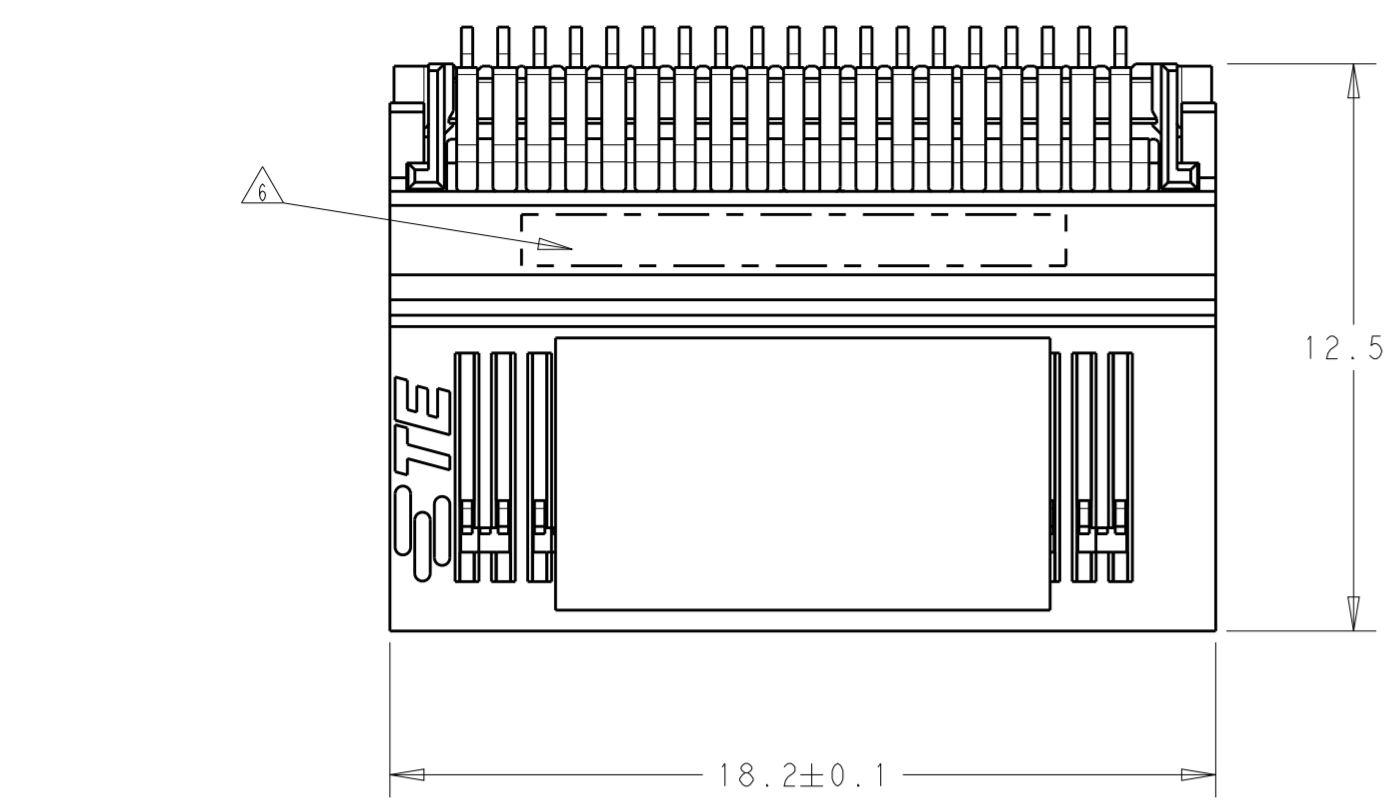

- 1 MATERIAL: GLASS FILLED LCP (BLACK) FOR HOUSING, ORGANISER AND CONTACT-OVERMOLDS.UL 94V-0.
- 2 MATERIAL: COPPER ALLOY FOR CONTACTS.
- 3 FINISH: 0,38µm MIN. GOLD, APPLIES TO INTERFACE AREA AND 3,0 µm MIN. MATTE TIN ON SOLDER TAILS, BOTH OVER 1,27 µm MIN. NICKEL ALL OVER. LUBRICANT ON GOLD PLATE CONTACT AREAS.
- 4 FINISH: 0,76µm MIN. GOLD, APPLIES TO INTERFACE AREA AND 3,0 µm MIN. MATTE TIN ON SOLDER TAILS, BOTH OVER 1,27 µm MIN. NICKEL ALL OVER. LUBRICANT ON GOLD PLATE CONTACT AREAS.
- 5 DATUM AND BASIC DIMENSION ESTABLISHED BY CUSTOMER.
- 6 CONNECTOR MARKED WITH PARTNUMBER AND DATE CODE.
- 7 PACKAGE SPEC (TAPE/REEL): WIDTH 32mm X PITCH 20mm.
- 8 PACKAGE SPEC (TAPE/REEL): WIDTH 44mm X PITCH 24mm, PIN 1 IS AT QUADRANT3.
- 9 PACKAGE SPEC (TAPE/REEL): WIDTH 44mm X PITCH 24mm, PIN 1 IS AT QUADRANT2.
- 10 PACKAGE SPEC (TAPE/REEL): WIDTH 44mm X PITCH 24mm, PIN 1 IS AT QUADRANT3. CUSTOMIZED FOR AUTO PICK & PLACE.
- 11 FINISH: 0,76µm MIN. GOLD, APPLIES TO INTERFACE AREA AND 3,0 µm MIN. MATTE TIN ON SOLDER TAILS, BOTH OVER 2,54 µm MIN. NICKEL ALL OVER. LUBRICANT ON GOLD PLATE CONTACT AREAS.

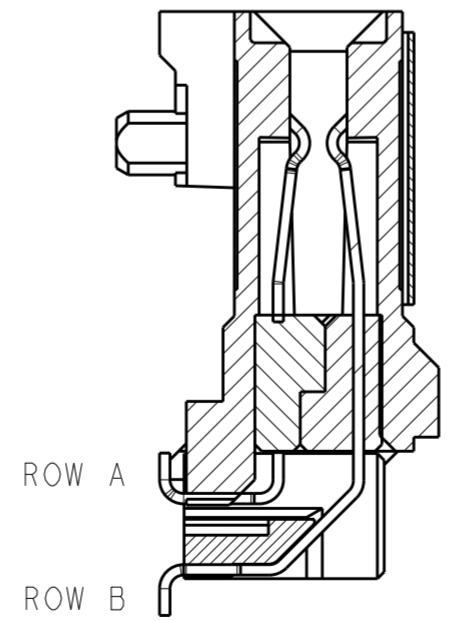
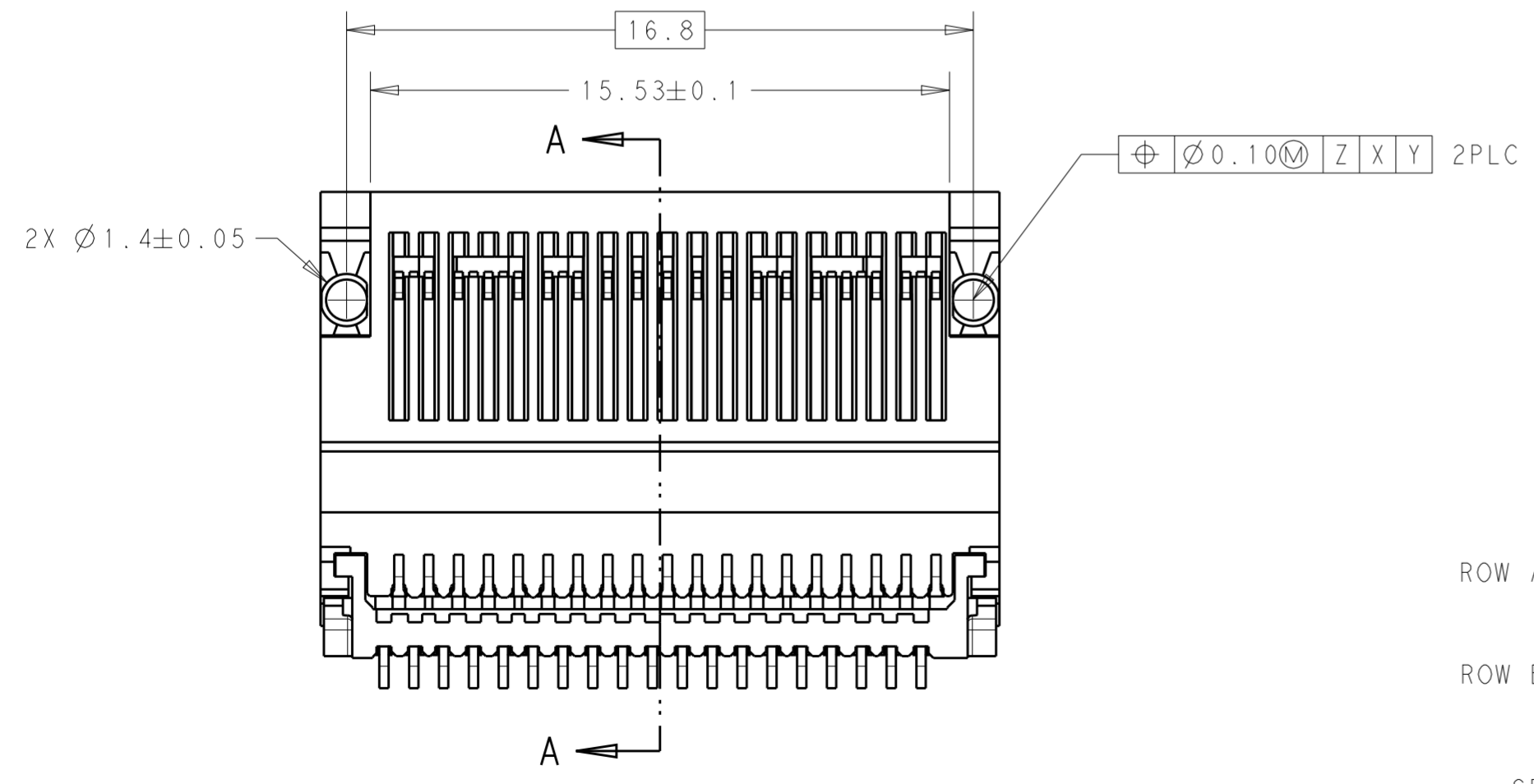
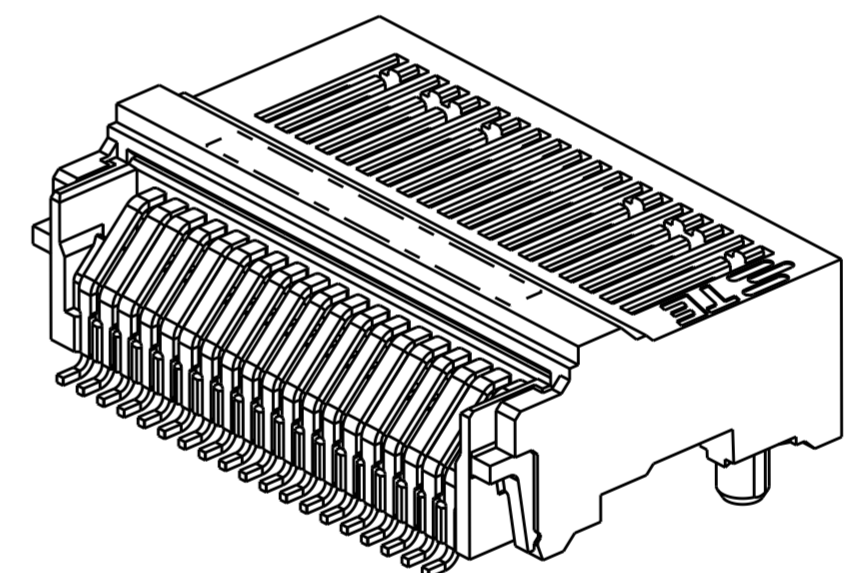
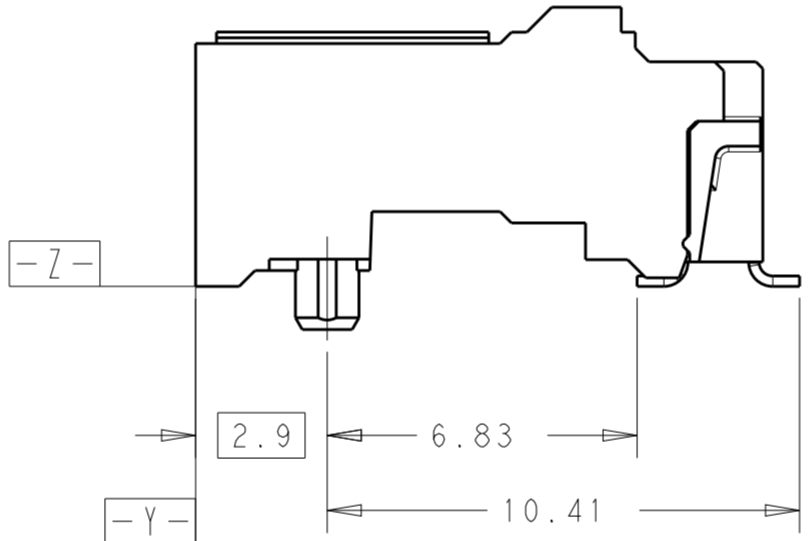
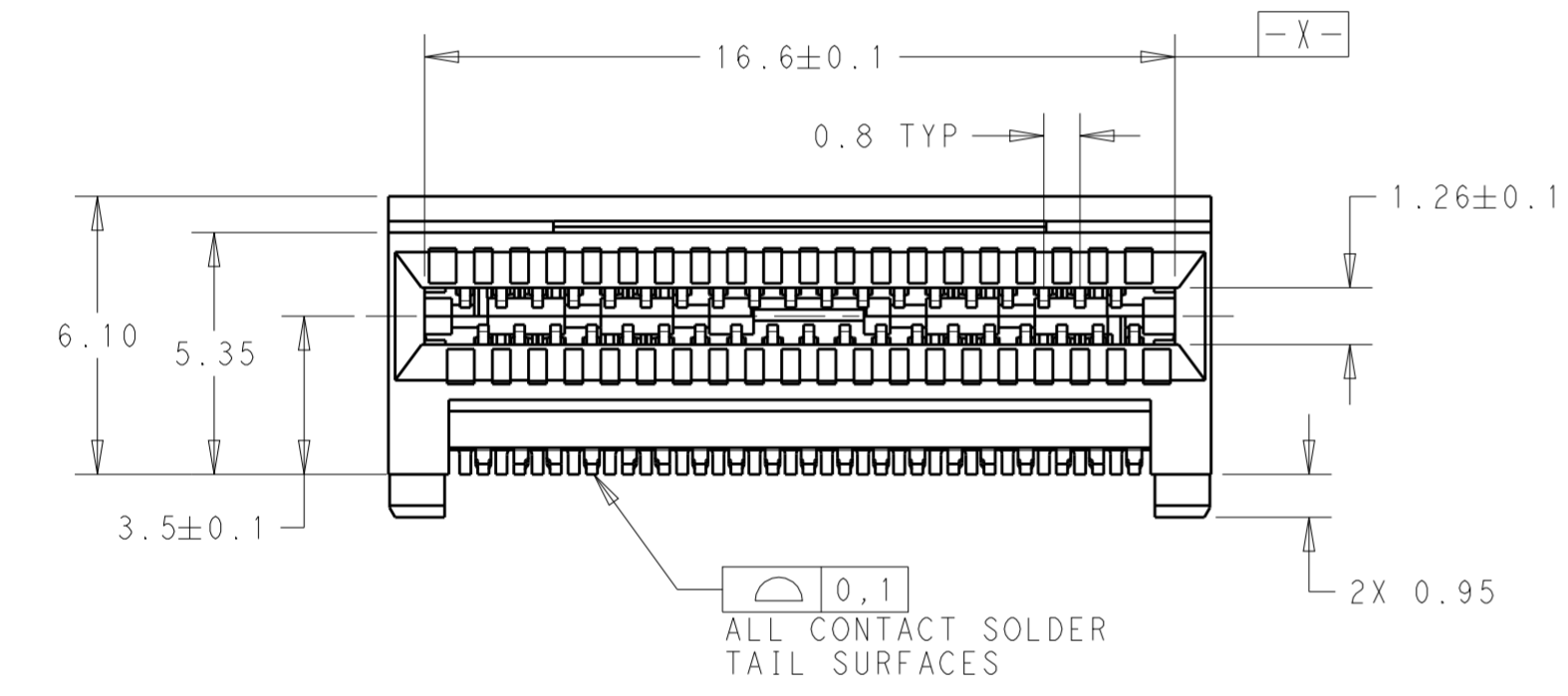
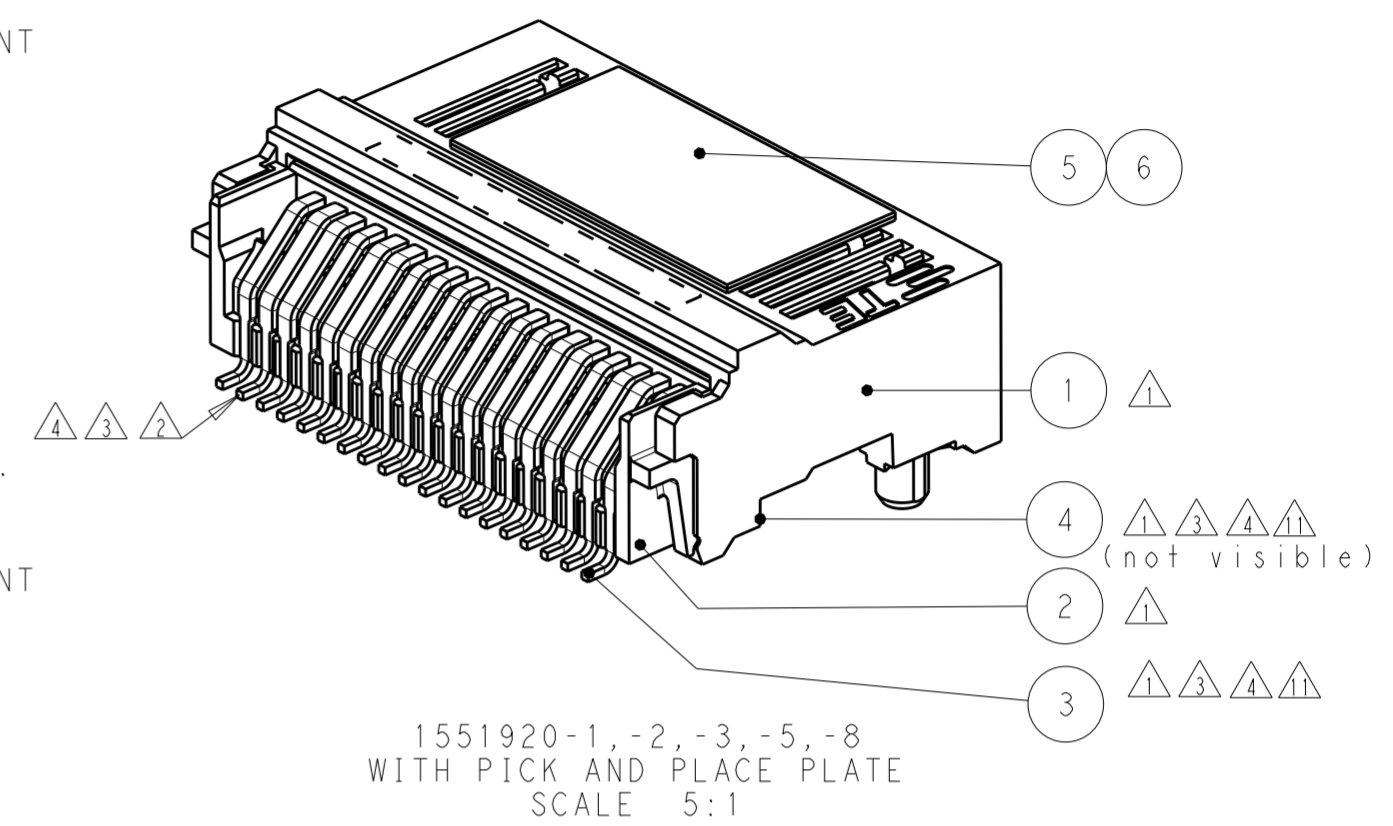

SECTION A-A

ITEM NO.	DESCRIPTION	1551920-1	1551920-2	1551920-3	1551920-4	1551920-5	1551920-6	1551920-7	1551920-8	2-1551920-1	2-1551920-2	2-1551920-3	2-1551920-4	2-1551920-5
7	RETENTION WASHER	-	-	-	2	-	-	-	-	-	-	-	-	2
6	PICK AND PLACE PLATE WHITE	-	-	-	-	-	-	-	-	1	1	1	1	1
5	PICK AND PLACE PLATE CLEAR	1	1	1	1	1	-	-	1	-	-	-	-	-
4	OVERMOLDED CONTACTS BOTTOM (19 CONTACTS)	1	1	1	1	1	1	1	1	1	1	1	1	1
3	OVERMOLDED CONTACTS TOP (19 CONTACTS)	1	1	1	1	1	1	1	1	1	1	1	1	1
2	ORGANISER	1	1	1	1	1	1	1	1	1	1	1	1	1
1	HOUSING	1	1	1	1	1	1	1	1	1	1	1	1	1

THIS DRAWING IS A CONTROLLED DOCUMENT.

DWN: E. ZIJLSTRA 17FEB2011
 CHK: B. MOOLIJ 17FEB2011
 APVD: T. d. BOER

NAME: zQSFP+ CONNECTOR 38 POSITIONS

SIZE: A2 CAGE CODE: 00779 DRAWING NO: C-1551920

SCALE: 4:1 SHEET: 1 OF 3 REV: N

1471-9 (3/13)

THIS DRAWING IS UNPUBLISHED. RELEASED FOR PUBLICATION
 © COPYRIGHT - BY - ALL RIGHTS RESERVED.

REVISIONS				
P	LTR	DESCRIPTION	DATE	APVD
-	-	SEE SHEET 1	-	-

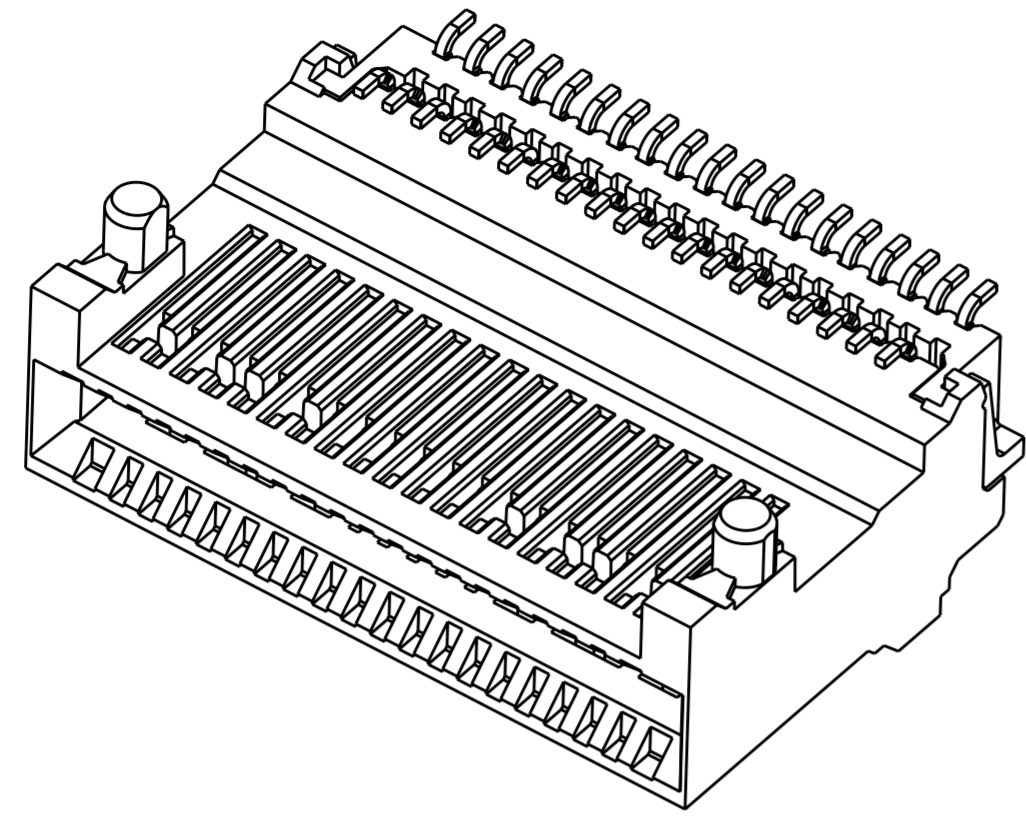

1551920-1, -2, -3, -5, -6, -7, -8
 2-1551920-1, 2-2, 2-3, 2-5 AS SHOWN
 WITHOUT RETENTION WASHER
 SCALE 6:1

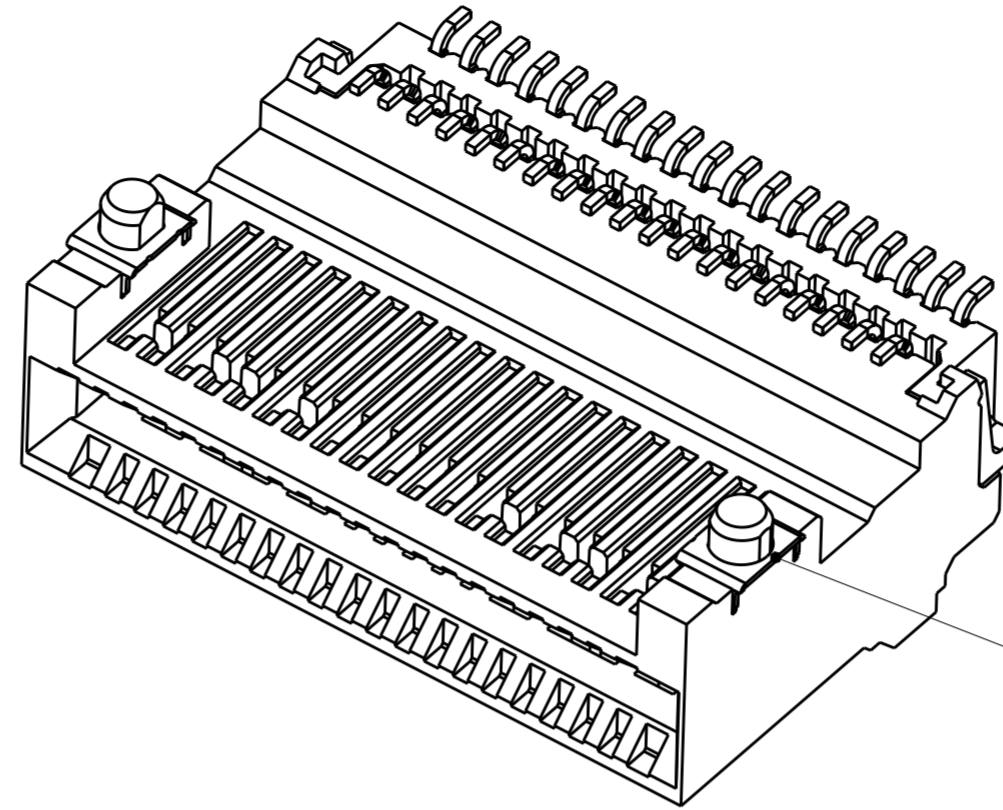

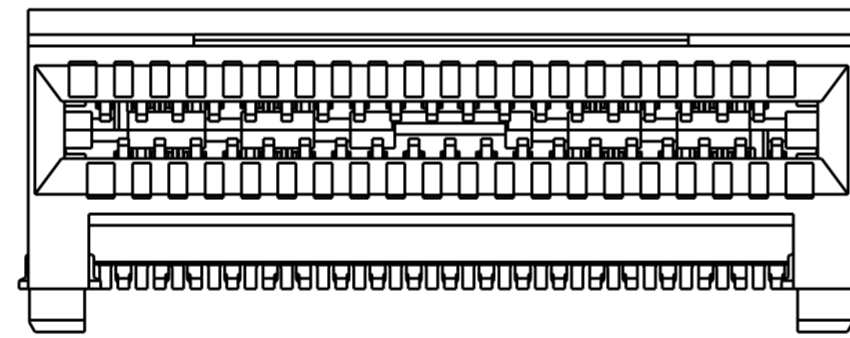

7
 RETENTION WASHER

1551920-4/2-1551920-4 AS SHOWN
 WITH RETENTION WASHER
 SCALE 6:1

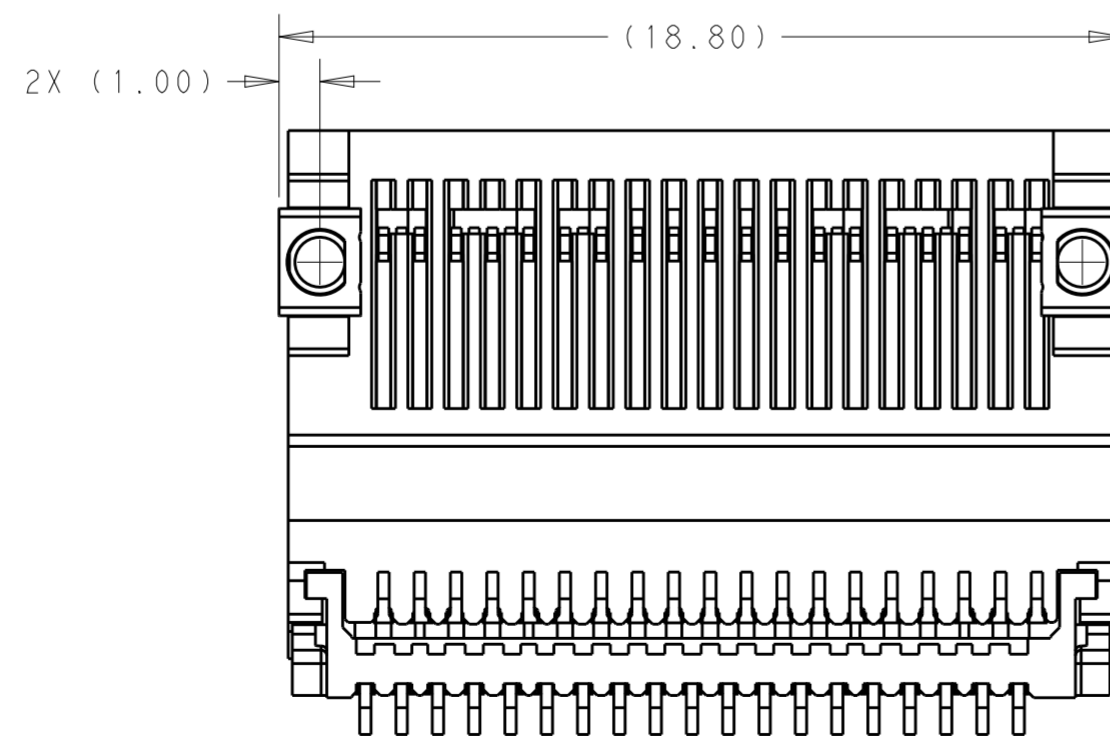
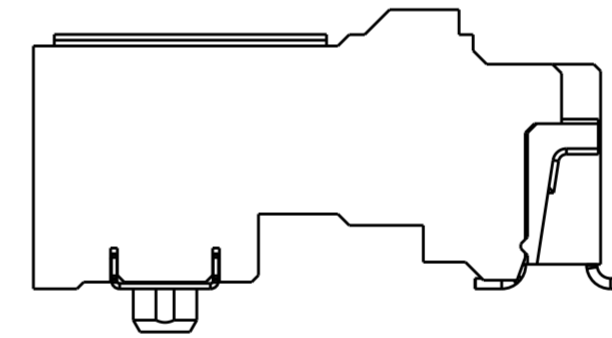

1551920-4/2-1551920-4 AS SHOWN
 UNSPECIFIED DIMENSIONS ARE SAME AS 1551920-1
 SCALE 6:1



THIS DRAWING IS A CONTROLLED DOCUMENT.		DWN E. ZIJLSTRA 17FEB2011	 TE Connectivity	
DIMENSIONS:		CHK B. MOOIJ 17FEB2011		
mm	TOLERANCES UNLESS OTHERWISE SPECIFIED:	APVD I. d. BOER	NAME ZQSFP+ CONNECTOR 38 POSITIONS	
0 PLC ±0.13	1 PLC ±0.13	PRODUCT SPEC 108-19428	SIZE	CAGE CODE
2 PLC ±0.13	3 PLC ±	APPLICATION SPEC 114-32022	A200779	C-1551920
4 PLC ±	ANGLES ±	WEIGHT	SCALE	SHEET
FINISH		CUSTOMER DRAWING	4:1	2 OF 3
				REV N

THIS DRAWING IS UNPUBLISHED. RELEASED FOR PUBLICATION
 © COPYRIGHT - BY - ALL RIGHTS RESERVED.

REVISIONS				
P	LTR	DESCRIPTION	DATE	APVD
-	-	SEE SHEET 1	-	-

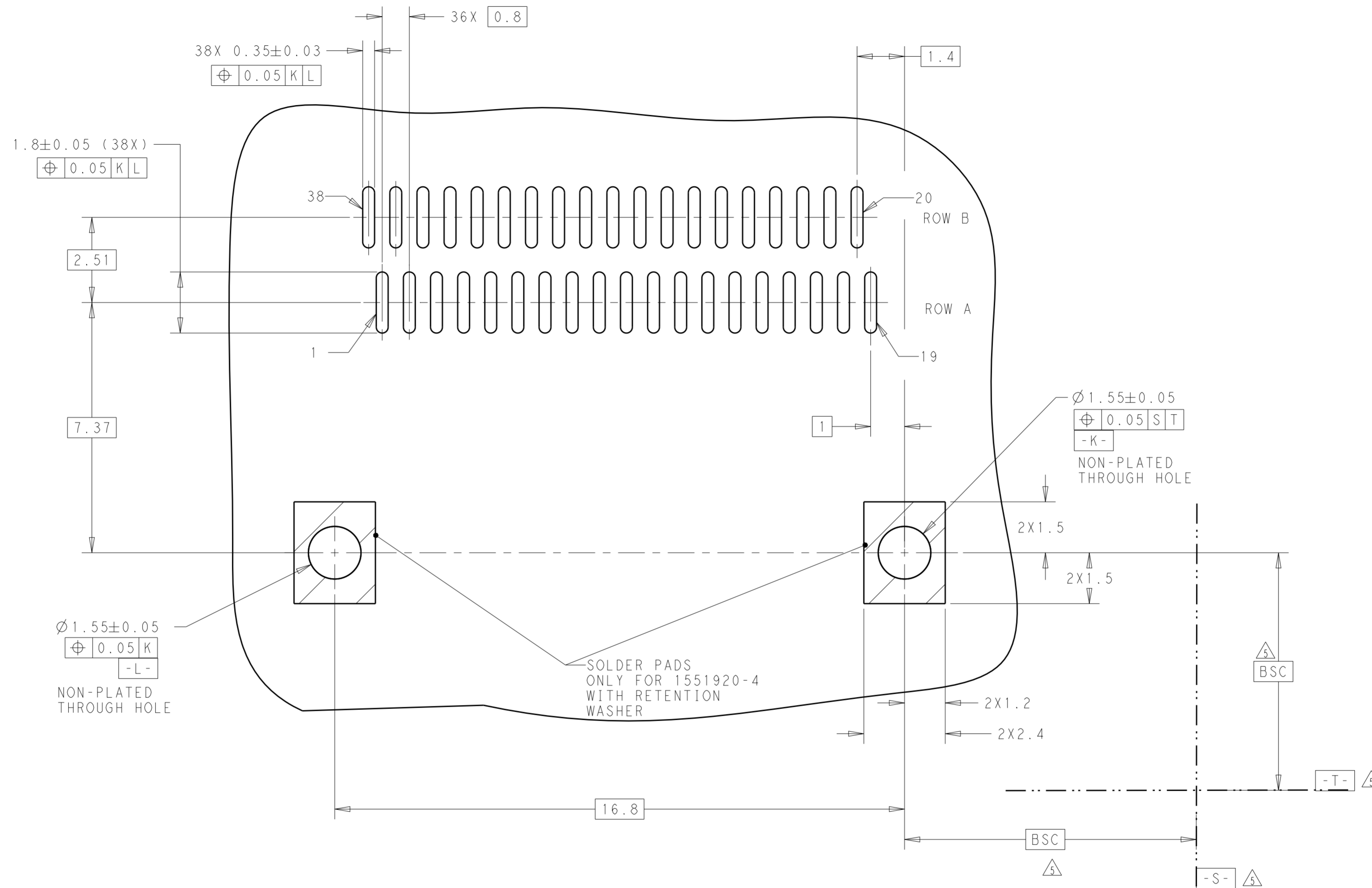

RECOMMENDED PCB-BOARD LAYOUT

THIS DRAWING IS A CONTROLLED DOCUMENT.		DWN E. ZIJLSTRA 17FEB2011	TE Connectivity	
		CHK B. MOOIJ 17FEB2011		
DIMENSIONS: mm		APVD T. d. BOER	NAME ZQSFP+ CONNECTOR 38 POSITIONS	
TOLERANCES UNLESS OTHERWISE SPECIFIED: 0 PLC ±0.13 1 PLC ±0.13 2 PLC ±0.13 3 PLC ± 4 PLC ± ANGLES ± FINISH ±		PRODUCT SPEC 108-19428	RESTRICTED TO	
MATERIAL		APPLICATION SPEC 114-32022	SIZE A200779	DRAWING NO C-1551920
		WEIGHT	SCALE 4:1 SHEET 3 OF 3 REV N	
		CUSTOMER DRAWING		