Features

- Very High Transmitting Frequency Accuracy Compared to SAW Solutions (Enables Receivers at Lower Bandwidth than with SAW Resonators)
- Lower Cost than the Usual Discrete Solutions Using SAW and Transistors
- Supply Voltage 2.2 V to 4.0 V in the Temperature Range of -40°C to 85°C
- XTO Output for Clocking the Microcontroller, Together with the ATAR090 or ATAR890 Results in the Optimum System Cost-effectiveness
- One-chip Solution with Minimum External Circuitry
- Very Small SSO16 Package, Pitch 0.635, 150 mil
- “Single-ended Open-collector” Output (Same Antennas Can Be Used as in Discrete Solutions, Simpler Adaptation of Magnetic Loop Antennas)
- ESD Protection According to MIL-STD.883 (4 KV HBM) Except Pins XTO1/ 2, ANT and LF

Electrostatic sensitive device.
Observe precautions for handling.



Description

The U2745B is a PLL transmitter IC which has been especially developed for the demands of RF low-cost data transmission systems at data rates up to 20 kBaud.

The transmitting frequency range is 310 MHz to 440 MHz. It can be used in ASK systems. The main applications of the U2745B are in the areas of outside temperature metering, socket control, garage door opener, consumption metering, light/fan or air-condition control, jalousies, wireless keyboard and various other consumer market applications.



UHF ASK Transmitter

U2745B

Rev. 4734A-RKE-11/03



Figure 1. System Block Diagram

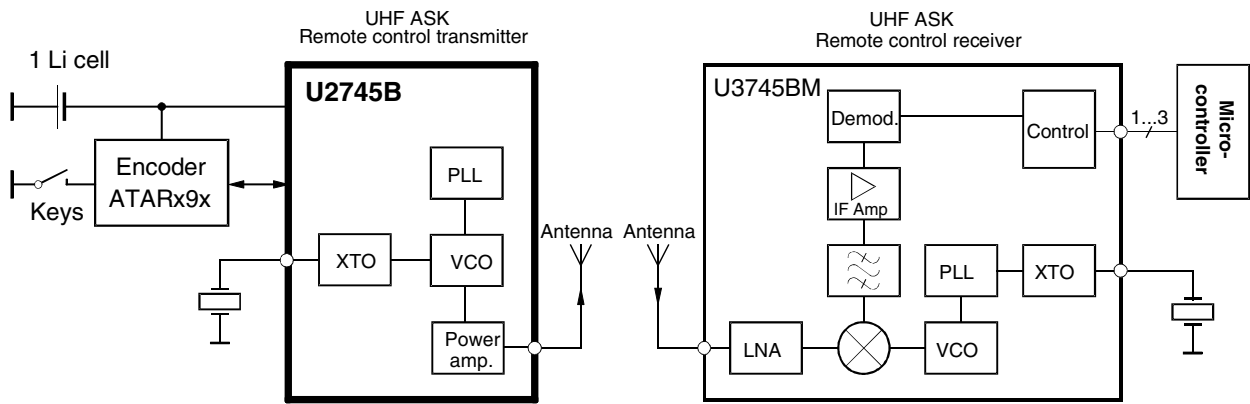
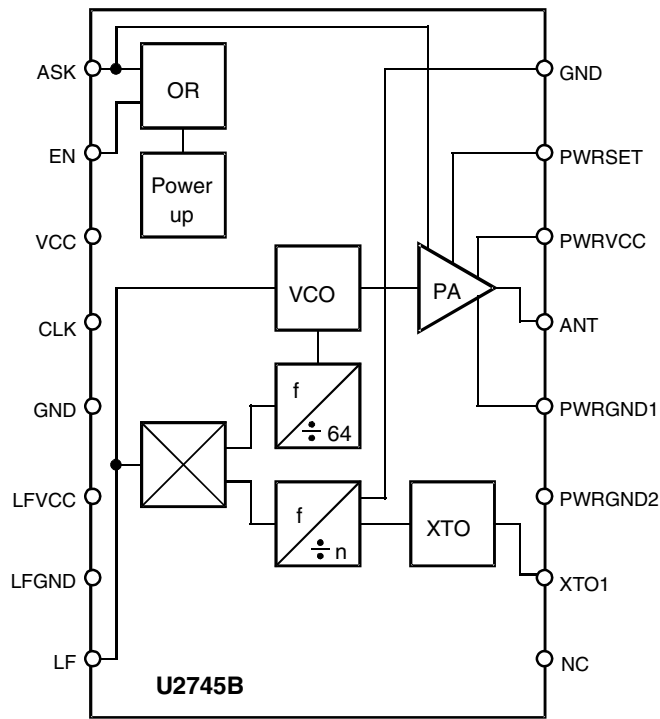
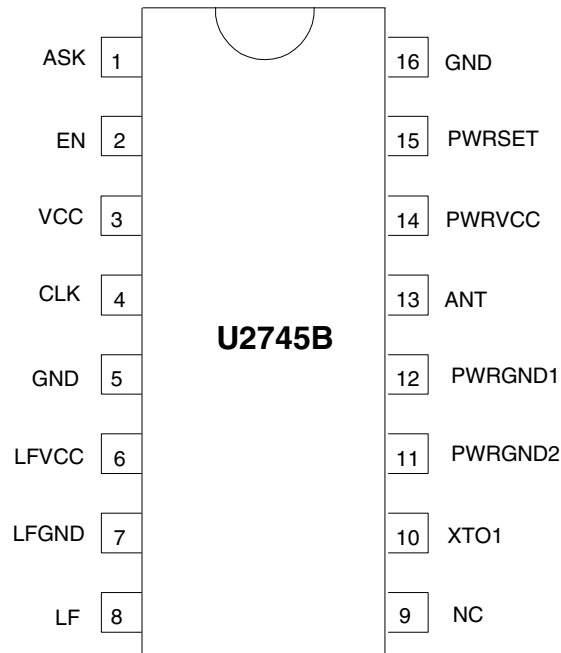

Figure 2. Block Diagram



Pin Configuration

Figure 3. Pinning SSO16



Pin Description

Pin	Symbol	Function
1	ASK	Modulation input ASK
2	EN	Enable input
3	VCC	Supply voltage
4	CLK	Clock output
5	GND	Ground
6	Lfvcc	Supply voltage VCO
7	LFGND	VCO ground
8	LF	Circuit PLL loop
9	NC	Not connected
10	XTO1	Connection for crystal
11	PWRGND2	Power GND2
12	PWRGND1	Power GND1
13	ANT	RF output
14	PWRVCC	Supply voltage power amplifier
15	PWRSET	Applied to VCC
16	GND	Ground

General Description

The fully integrated VCO and the “single-ended open-collector” output allow particularly simple, low-cost RF miniature transmitters to be assembled. The single-ended output enables a considerably simplified adaptation of both a magnetic loop antenna of any form or a $\lambda/4$ antenna. This is because the load impedance must not be balanced as would be the case with a differential output.

The XTO's frequency can be selected to be either 13.56 MHz or 9.844 MHz (USA). At these frequencies, crystals have a very fast start-up time (< 1.5 ms), whereby a wait time of 5 to 10 ms is required until the transmitter IC is locked. This means that the processor does not need to poll a lock detect output.

Functional Description

ASK Transmission

The U2745B is activated by $EN = V_S$. V_{ASK} must remain 0 V for 5 ms, then the output power can be modulated by means of pin ASK. V_{EN} remains $= V_S$ during the transmission of the message. The ASK input activates the power amplifier and the PLL.

Take-over of the Clock Pulse in the Microcontroller

The clock of the crystal oscillator can be used for clocking the microcontroller. The ATAR090 and ATAR890 have the special feature of starting with an integrated RC oscillator to switch on the U2745B with $V_{EN} = V_S$. 5 ms later, the 3.39-MHz clock frequency is present, so that the message can be sent with crystal accuracy.

Application Circuit

The following component values are recommendations for a typical application. C_4 , C_5 , and C_6 are block capacitors. The values of these capacitors depend on the board layout. $C_4 = 1$ nF, $C_5 = 1$ nF, and $C_6 = 22$ nF are typically used here. For C_5 , the impedance between $f = 100$ MHz and $f = 1$ GHz should be as low as possible.

C_{Loop1} and C_{Loop2} are selected so that the antenna oscillates in resonance and the adaptation to the appropriate impedance transformation is possible.

L_{Feed} is an inductor for the antenna's DC current supply. A typical value is $L_{Feed} = 220$ nH. L_{Feed} can be either printed on the PC board or be a discrete component.

Output Power Measurement

The following output network (see Figure 4 on page 5) can be used for output power evaluation, the exact values of L_{10} and C_{10} are dependent on the layout.

L_{10} and C_{10} form the transformation network to adopt the output impedance of the IC to 50Ω . The following table shows the values for an output power of 2 mW and an $R_{PWRSET} = 1.2$ k Ω .

Table 1. Transformation Network

f/MHz	C10/pF	L10/nH	Z_{Load_opt}/Ω
315	2.7	56	$260 + j330$
433.92	1.8	33	$185 + j268$

Figure 4. Measurement Output Network

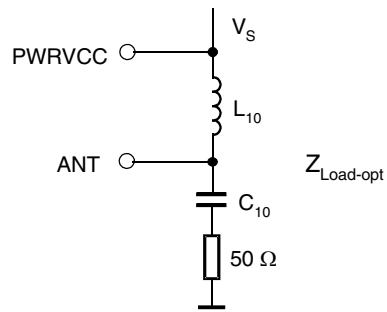
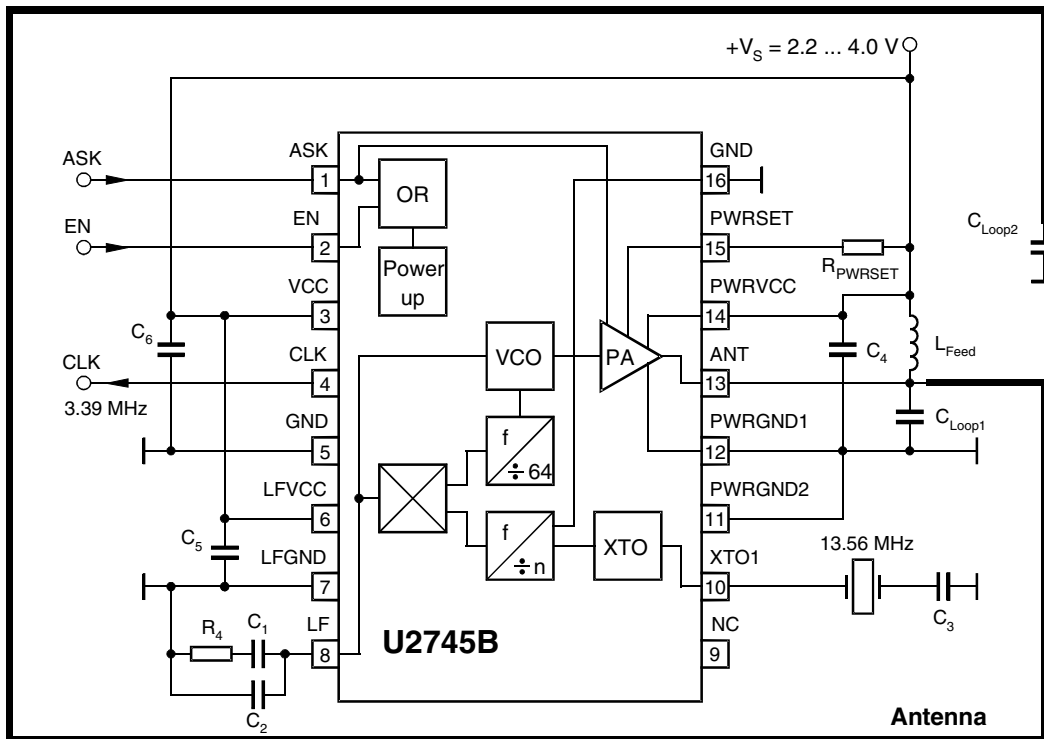

Figure 5. Application Circuit



Absolute Maximum Ratings

Stresses beyond those listed under “Absolute Maximum Ratings” may cause permanent damage to the device. This is a stress rating only and functional operation of the device at these or any other conditions beyond those indicated in the operational sections of this specification is not implied. Exposure to absolute maximum rating conditions for extended periods may affect device reliability.

Parameters	Symbol	Min.	Max.	Unit
Supply voltage	V_S		6	V
Power dissipation	P_{tot}		250	mW
Junction temperature	T_j		150	°C
Storage temperature	T_{stg}	-55	125	°C
Ambient temperature	T_{amb}	-40	85	°C

Thermal Resistance

Parameters	Symbol	Value	Unit
Junction ambient	R_{thJA}	180	K/W

Electrical Characteristics

All parameters are referred to GND (pin 5), $V_S = 3\text{ V}$, $T_{amb} = 25^\circ\text{C}$, unless otherwise specified

The possible operating ranges refer to different circuit conditions: $V_S = 2.2\text{ V}$ to 4.0 V at $T_{amb} = -40^\circ\text{C}$ to $+85^\circ\text{C}$

Parameters	Test Conditions	Symbol	Min.	Typ.	Max.	Unit
Supply current (power down)	$V_{ASK}, V_{FSK} \leq 0.3\text{ V}$, $V_S < 3.6\text{ V}$	I_{Soff}		2	10	μA
Supply current (power up, output OFF)	$V_{ASK} = \text{GND}$, $V_{EN} = V_S$, $V_S = 3\text{ V}$	I_{Son}		4.7	6.2	mA
Supply current (power up, output ON)	$V_{ASK} = V_S$, $V_S = 3\text{ V}$, $R_{PWRSET} = 1.2\text{ k}\Omega$	$I_{Stransmit}$		10	12.5	mA
Output power	$V_S = 3\text{ V}$, $T_{amb} = 25^\circ\text{C}$, $f = 433.92\text{ MHz}$ $R_{PWRSET} = 1.2\text{ k}\Omega$	P_{Ref}	1	3	5	dBm
Output power variation for $f = 315\text{ MHz}$ compared to $f = 433.92\text{ MHz}$	$f = 315\text{ MHz}$ $P_{out} = P_{Ref} + \Delta P_{Ref}$	ΔP_{Ref}		1.5		dB
Maximum peak output antenna voltage	at $P_{out} = 2.0\text{ mW}$, the load impedance must be selected to meet the V_{out} maximum requirement, the supply current is not dependent on the load impedance tolerance	V_{outmax}		$V_S - 0.7\text{ V}$		$V_{(peak)}$
Spurious emission	$f_o \pm (n \times f_{PC})$ where $f_{PC} = 6.78\text{ MHz}$ Load capacitance at CLK $\leq 3\text{ pF}$ $f = 230\text{ MHz}$ to 470 MHz $f < 230\text{ MHz}$, $f > 470\text{ MHz}$	E_m E_m			-40 -58	dBc dBc
Oscillator frequency XTO	Crystal frequency = 13.56 MHz	f_{XTO}	13.56 - 30 ppm	13.56	13.56 + 30 ppm	MHz
Loop bandwidth	For best LO noise Loop filter components: $C_2 = 3.9\text{ nF}$, $C_1 = 15\text{ nF}$, $R_4 = 220\ \Omega$	B_{Loop}		100		kHz
Phase noise PLL	Referring to the phase comparator $f_{PC} = 6.78\text{ MHz}$	PN_{PLL}		-111	-105	dBc/Hz
Phase noise VCO	at 1 MHz at 36 MHz	PN_{VCO} PN_{VCO}		-90 -122		dBc/Hz

Electrical Characteristics (Continued)

All parameters are referred to GND (pin 5), $V_S = 3\text{ V}$, $T_{amb} = 25^\circ\text{C}$, unless otherwise specified

The possible operating ranges refer to different circuit conditions: $V_S = 2.2\text{ V}$ to 4.0 V at $T_{amb} = -40^\circ\text{C}$ to $+85^\circ\text{C}$

Parameters	Test Conditions	Symbol	Min.	Typ.	Max.	Unit
Frequency range of the VCO		f_{VCO}	310		440	MHz
Clock output (CMOS microcontroller compatible)		Clk_{out}		$f_{out}/128$		MHz
Load capacitance at CLK		C_{CLK}			10	pF
Series resonance R of the crystal	$f_{XTO} = 13.56\text{ MHz}$ $f_{XTO} = 9.84\text{ MHz}$	R_s R_s			80 100	Ω
ASK modulation frequency rate	Duty cycle of the modulation signal = 50%	f_{modASK}	0		20	kHz
CLK output - Output current Low - Output current Low - Output current High - Output current High	$V_{CLK} = 0.2 \times V_S$ $V_{CLK} = 0.3 \times V_S$ $V_{CLK} = 0.8 \times V_S$ $V_{CLK} = 0.7 \times V_S$	I_{ol} I_{ol} I_{oh} I_{oh}	150 200 -150 -200		100	μA μA μA μA
ASK input - Low level input voltage - High level input voltage - Input current High		V_{ASKl} V_{ASKh} I_{ASKh}	1.7		0.3 140	V V μA
Enable ASK - Low level input voltage - High level input voltage - Input current High		V_{EN} V_{FSKl} V_{FSKh} I_{FSKh}	1.7		0.3 140	V V μA

Ordering Information

Extended Type Number	Package	Remarks
U2745B-MFB	SSO16	Tube
U2745B-MFBG3	SSO16	Taped and reeled

Package Information

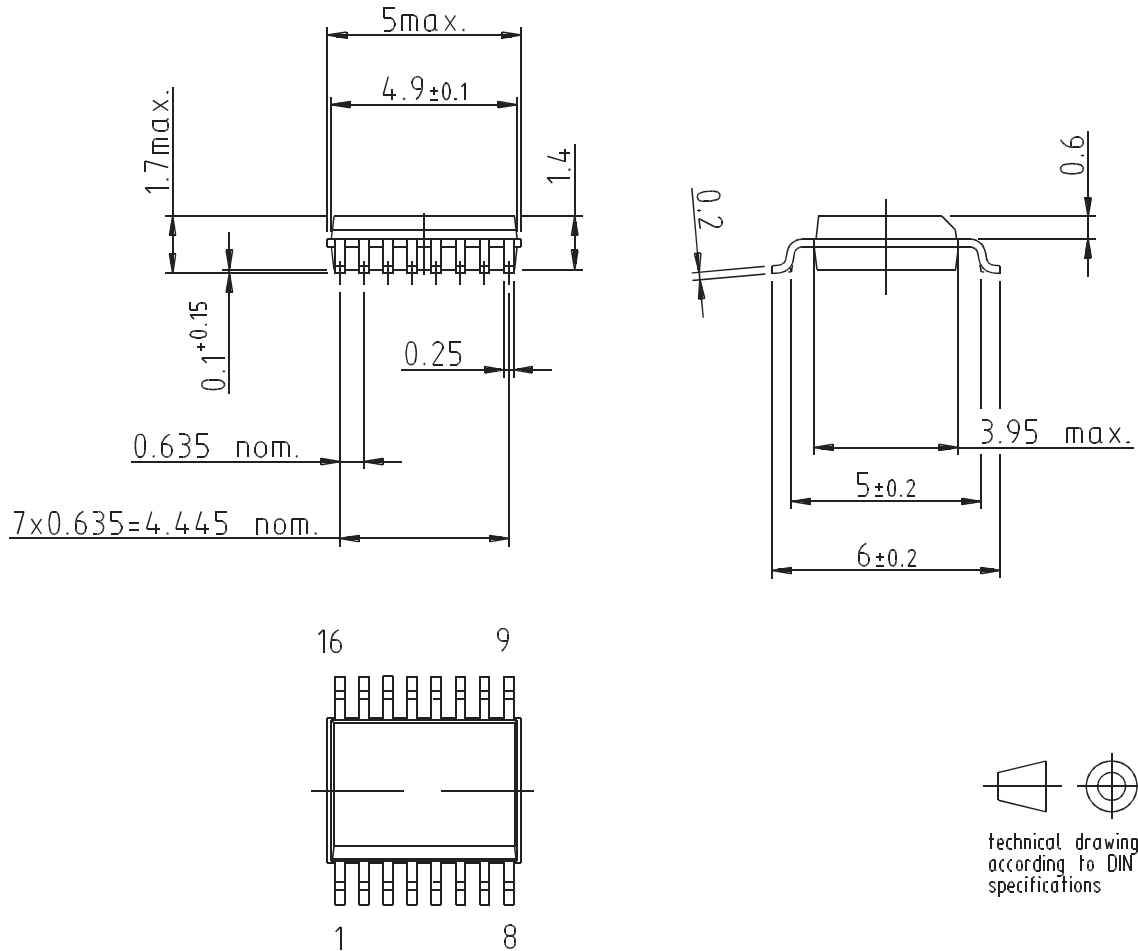

Drawing refers to following types: SSO16
 Package acc. JEDEC MO 137 AB



Atmel Corporation

2325 Orchard Parkway
San Jose, CA 95131, USA
Tel: 1(408) 441-0311
Fax: 1(408) 487-2600

Regional Headquarters

Europe

Atmel Sarl
Route des Arsenalux 41
Case Postale 80
CH-1705 Fribourg
Switzerland
Tel: (41) 26-426-5555
Fax: (41) 26-426-5500

Asia

Room 1219
Chinachem Golden Plaza
77 Mody Road Tsimshatsui
East Kowloon
Hong Kong
Tel: (852) 2721-9778
Fax: (852) 2722-1369

Japan

9F, Tonetsu Shinkawa Bldg.
1-24-8 Shinkawa
Chuo-ku, Tokyo 104-0033
Japan
Tel: (81) 3-3523-3551
Fax: (81) 3-3523-7581

Atmel Operations

Memory

2325 Orchard Parkway
San Jose, CA 95131, USA
Tel: 1(408) 441-0311
Fax: 1(408) 436-4314

Microcontrollers

2325 Orchard Parkway
San Jose, CA 95131, USA
Tel: 1(408) 441-0311
Fax: 1(408) 436-4314

La Chantrerie
BP 70602
44306 Nantes Cedex 3, France
Tel: (33) 2-40-18-18-18
Fax: (33) 2-40-18-19-60

ASIC/ASSP/Smart Cards

Zone Industrielle
13106 Rousset Cedex, France
Tel: (33) 4-42-53-60-00
Fax: (33) 4-42-53-60-01

1150 East Cheyenne Mtn. Blvd.
Colorado Springs, CO 80906, USA
Tel: 1(719) 576-3300
Fax: 1(719) 540-1759

Scottish Enterprise Technology Park
Maxwell Building
East Kilbride G75 0QR, Scotland
Tel: (44) 1355-803-000
Fax: (44) 1355-242-743

RF/Automotive

Theresienstrasse 2
Postfach 3535
74025 Heilbronn, Germany
Tel: (49) 71-31-67-0
Fax: (49) 71-31-67-2340

1150 East Cheyenne Mtn. Blvd.
Colorado Springs, CO 80906, USA
Tel: 1(719) 576-3300
Fax: 1(719) 540-1759

Biometrics/Imaging/Hi-Rel MPU/ High Speed Converters/RF Datacom

Avenue de Rochepleine
BP 123
38521 Saint-Egreve Cedex, France
Tel: (33) 4-76-58-30-00
Fax: (33) 4-76-58-34-80

Literature Requests

www.atmel.com/literature

Disclaimer: Atmel Corporation makes no warranty for the use of its products, other than those expressly contained in the Company's standard warranty which is detailed in Atmel's Terms and Conditions located on the Company's web site. The Company assumes no responsibility for any errors which may appear in this document, reserves the right to change devices or specifications detailed herein at any time without notice, and does not make any commitment to update the information contained herein. No licenses to patents or other intellectual property of Atmel are granted by the Company in connection with the sale of Atmel products, expressly or by implication. Atmel's products are not authorized for use as critical components in life support devices or systems.

© Atmel Corporation 2003. All rights reserved.

Atmel® and combinations thereof are the registered trademarks of Atmel Corporation or its subsidiaries.

Other terms and product names may be the trademarks of others.



Printed on recycled paper.