

THIS IS A C.A.D. GENERATED DRAWING
DO NOT MAKE MANUAL REVISIONS TO MASTER.

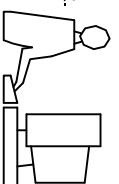

ISSUE NUMBER
REMOVE P/N: 690-009-221-900 R.STAMONICA MAY.07/10
⑥
ADD P/N: 690-009-521T900 AND 690-009-621T900 R.STAMONICA JUN.01/10
⑦
690-009-521-901 WAS 690-009-521T900 AND 690-009-621-901 WAS 690-009-621T900. ADD TAPE & REEL AND PCB TOLERANCE R.STAMONICA JUN.07/10
⑧

ELECTRICAL SPECIFICATIONS:

CURRENT RATING: 1 AMP .30VAC
CONTACT RESISTANCE: 30 MILLIOHMS MAX.
INSULATION RESISTANCE: 1000 MEGOHMS MIN.
DWV: 500VAC
TEMPERATURE RATING: -50°C TO +105°C

MATERIALS:

HOUSING AND COVER: PBT 30%G.F. UL94V-0 COLOR BLACK
CONTACTS: COPPER ALLOY, PLATED WITH 15 MICRONS OF GOLD
ON CONTACT AREA, TIN ON TAILS OVER NICKEL
SHELL: BRASS, NICKEL PLATED
COVER SHELL: COPPER ALLOY, NICKEL PLATED

PC BOARD MOUNTING DIMENSIONS

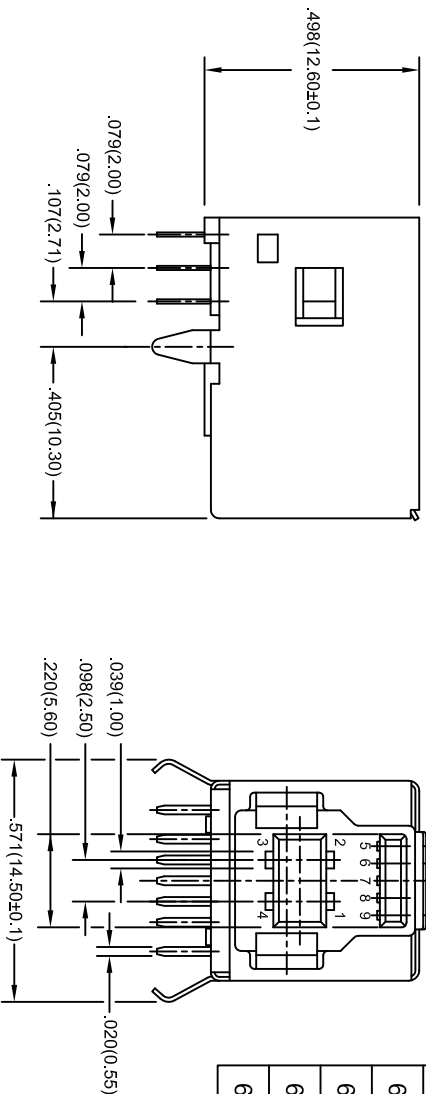
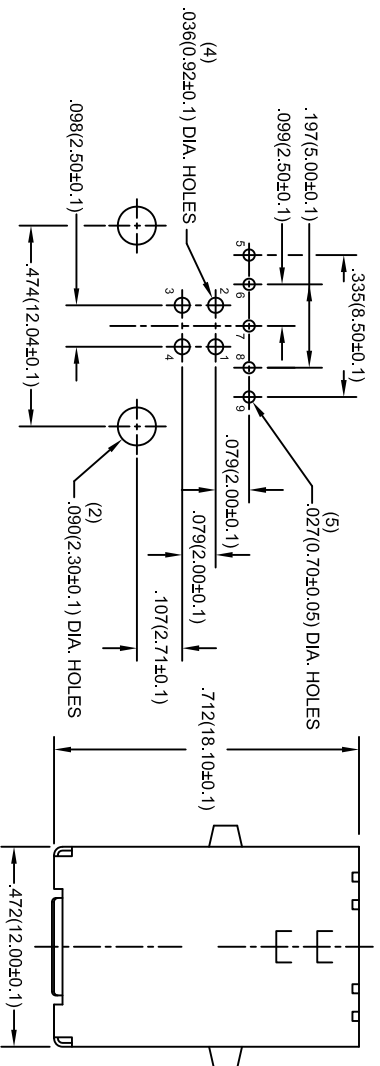

PART NUMBERS	GOLD PLATING	PACKAGING DETAIL
690-009-521-900	15 u" OF GOLD	TAPE AND REEL
690-009-521-901	15 u" OF GOLD	PLASTIC TRAY
690-009-621-900	30 u" OF GOLD	TAPE AND REEL
690-009-621-901	30 u" OF GOLD	PLASTIC TRAY

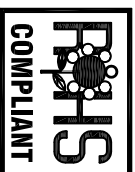

THIS SERIES FULLY CONFORMS TO THE
EUROPEAN UNION DIRECTIVES 2002/95/EC
AND 2002/96/EC FOR ROHS COMPLIANCY.

USB-B RECEPTACLE 90° DIP, 3.0 VERSION

ACAD REFERENCE NO.	690-009-521-900
DRAWN: F. BRIONES	DATE: AUG.17/09
PART NUMBER	SEE ABOVE
DRAWING NUMBER	690-009-521-900

EDAC INC
TORONTO, ONTARIO
CANADA

YOUR CONNECTION TO QUALITY & SERVICE

THESE DRAWINGS AND SPECIFICATIONS
ARE THE PROPERTY OF EDAC INC. AND
SHALL NOT BE REPRODUCED, OR COPIED
OR USED AS THE BASIS FOR THE
MANUFACTURE OR SALE OF APPARATUS
WITHOUT WRITTEN PERMISSION.

SHEET 1 OF 3
ISSUE
8

THIS IS A C.A.D. GENERATED DRAWING
DO NOT MAKE MANUAL REVISIONS TO MASTER.

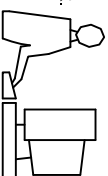

ISSUE NUMBER

SEE PAGE 1 OF 3

8

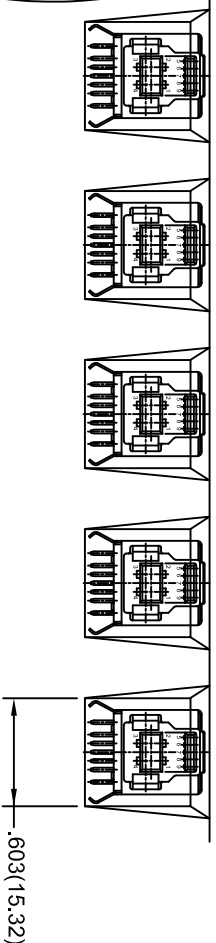
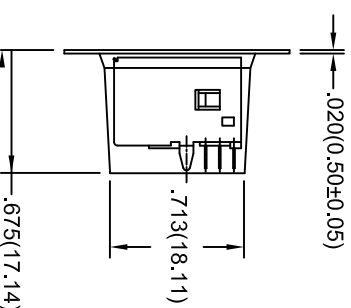
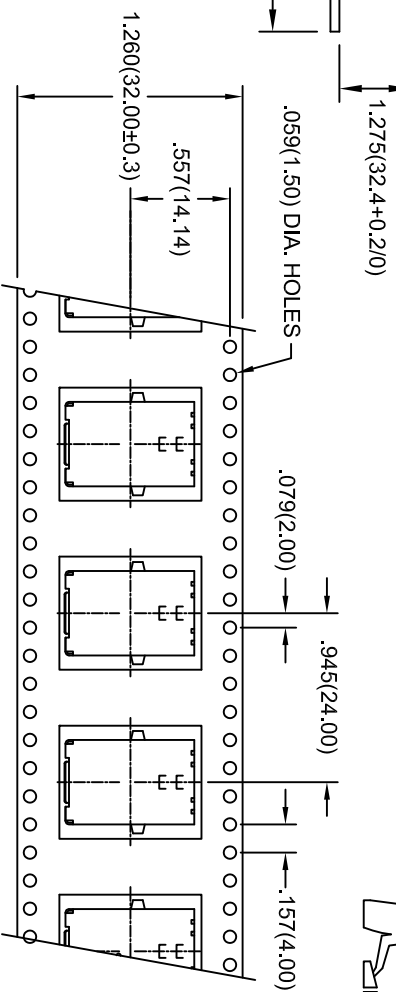
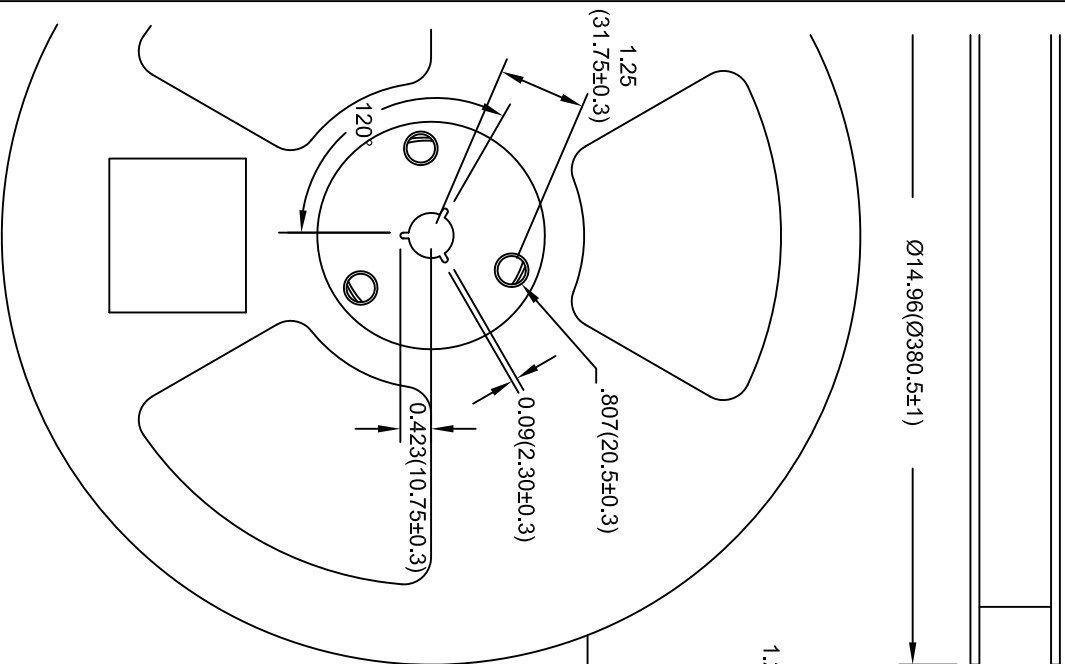

NOTE:
TOLERANCE FOR ALL DIMENSIONS IN MM IS ±0.1, UNLESS OTHERWISE SPECIFIED

**USB-B RECEPTACLE 90° DIP, 3.0 VERSION
PACKAGING REEL (200 PCS PER REEL)**

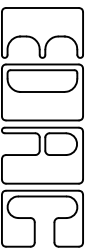

EDAC INC
TORONTO, ONTARIO
CANADA
YOUR CONNECTION TO QUALITY & SERVICE

THESE DRAWINGS AND SPECIFICATIONS
ARE THE PROPERTY OF EDAC INC. AND
SHALL NOT BE REPRODUCED, OR COPIED
OR USED AS THE BASIS FOR THE
MANUFACTURE OR SALE OF APPARATUS
WITHOUT WRITTEN PERMISSION.

ACAD REFERENCE NO. 690-009-521-013

DRAWN: F. BRIONES DATE: AUG. 17/09

PART NUMBER

SEE PAGE 1 OF 3

SHEET 2 OF 3

DRAWING NUMBER

690-009-521-900

ISSUE

8

THIS IS A C.A.D. GENERATED DRAWING
DO NOT MAKE MANUAL REVISIONS TO MASTER.

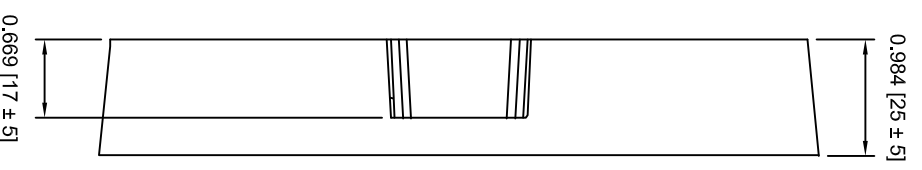
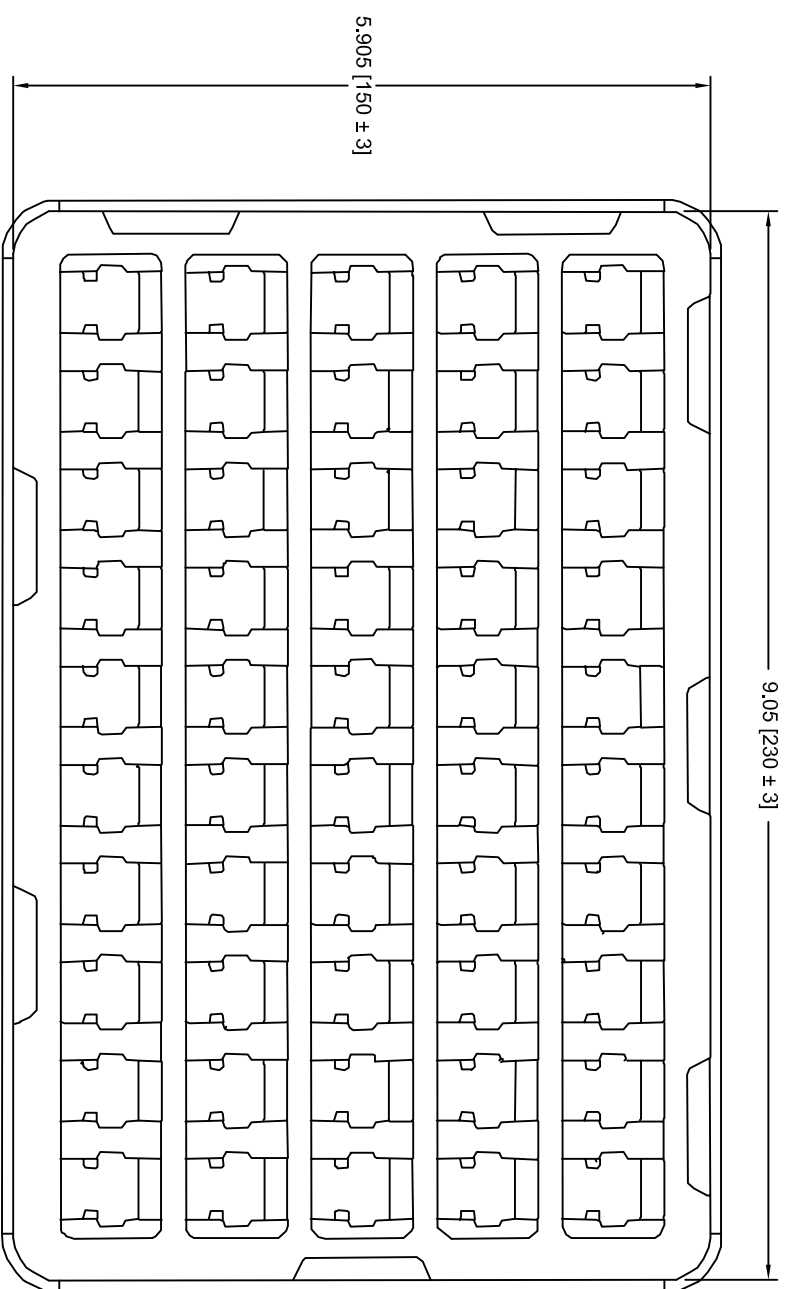
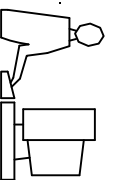

- NOTES:
1. MATERIAL: TRANSPARENT PVC
 2. THICKNESS: 0.20 ± 0.05MM
 3. PCS / TRAY : 50PCS
 4. TRAY / BOX : 30TRAYS
 5. PCS / BOX : 1500PCS
 6. CARTON SIZE:
480MM x 250MM x 200MM

**USB-B RECEPTACLE 90° DIP, 3.0 VERSION
TRAY PACKAGING (50 PCS PER TRAY)**

EDAC INC
TORONTO, ONTARIO
CANADA
YOUR CONNECTION TO QUALITY & SERVICE

THESE DRAWINGS AND SPECIFICATIONS
ARE THE PROPERTY OF EDAC INC., AND
SHALL NOT BE REPRODUCED, OR COPIED
OR USED AS THE BASIS FOR THE
MANUFACTURE OR SALE OF APPARATUS
WITHOUT WRITTEN PERMISSION.

ACAD REFERENCE NO.	690-009-521-013
DRAWN: R.STA. MONICA	DATE: JUN.01/10
PART NUMBER	SEE PAGE 1 OF 3
DRAWING NUMBER	690-009-521-900
	SHEET 3 OF 3
	ISSUE
	8