

DP83843

DP83843 PHYTER



Literature Number: SNLS021B

DP83843BVJE PHYTER

General Description

The DP83843BVJE is a full feature Physical Layer device with integrated PMD sublayers to support both 10BASE-T and 100BASE-X Ethernet protocols.

This VLSI device is designed for easy implementation of 10/100 Mb/s Ethernet LANs. It interfaces directly to Twisted Pair media through an external transformer or to fiber media via industry standard electrical/optical fiber PMD transceivers. This device also interfaces directly to the MAC layer through the IEEE 802.3u standard Media Independent Interface (MII), ensuring interoperability between products from different vendors.

The DP83843 is designed with National Semiconductor's advanced CMOS process. Its system architecture is based on the integration of several of National's industry proven core technologies:

- IEEE 802.3 ENDEC with AUI/10BASE-T transceiver module to provide the 10 Mb/s functions
- Clock Recovery/Generator Modules from National's Fast Ethernet and FDDI products
- FDDI Stream Cipher scrambler/descrambler for TP-PMD
- 100BASE-X physical coding sub-layer (PCS) and control logic that integrates the core modules into a dual speed Ethernet physical layer controller
- ANSI X3T12 Compliant TP-PMD Transceiver technology with Baseline Wander (BLW) compensation

Features

- IEEE 802.3 ENDEC with AUI/10BASE-T transceivers and built-in filters
- IEEE 802.3u 100BASE-TX compatible - directly drives standard Category 5 UTP, no need for external 100BASE-TX transceiver
- Fully Integrated and fully compliant ANSI X3.263 TP-PMD physical sublayer which includes adaptive equalization and BLW compensation
- IEEE 802.3u 100BASE-FX compatible - connects directly to industry standard Electrical/Optical transceivers
- IEEE 802.3u Auto-Negotiation for automatic speed selection
- IEEE 802.3u compatible Media Independent Interface (MII) with Serial Management Interface
- Integrated high performance 100 Mb/s clock recovery circuitry requiring no external filters
- Full Duplex support for 10 and 100 Mb/s data rates
- MII Serial 10 Mb/s mode
- Fully configurable node/switch and 100Mb/s repeater modes
- Programmable loopback modes for flexible system diagnostics
- Flexible LED support
- Single register access to complete PHY status
- MDIO interrupt support
- Individualized scrambler seed for 100BASE-TX applications using multiple PHYs
- Low power consumption for multi-port applications
- Small footprint 80-pin PQFP package

System Diagram

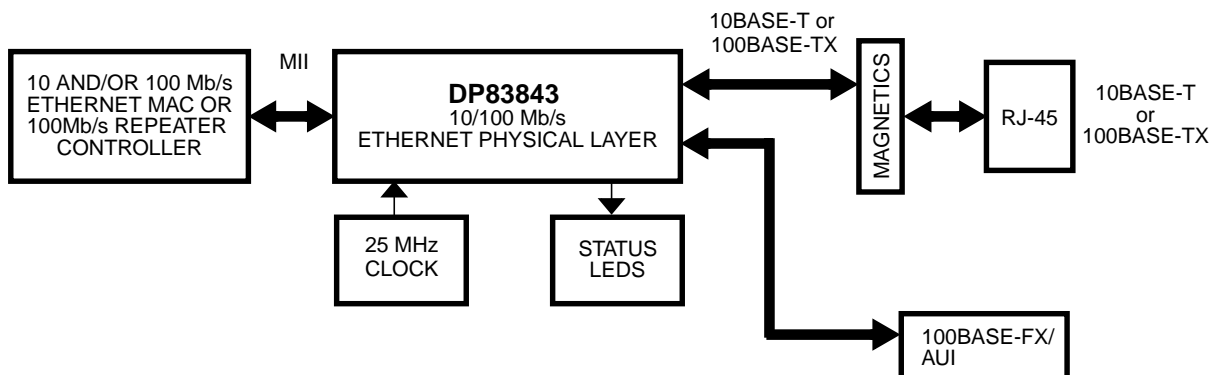

ThunderLAN® is a registered trademark of Texas Instruments.
 TWISTER™ is a trademark of National Semiconductor Corporation.
 TRI-STATE® is a registered trademark of National Semiconductor Corporation.

Block Diagram

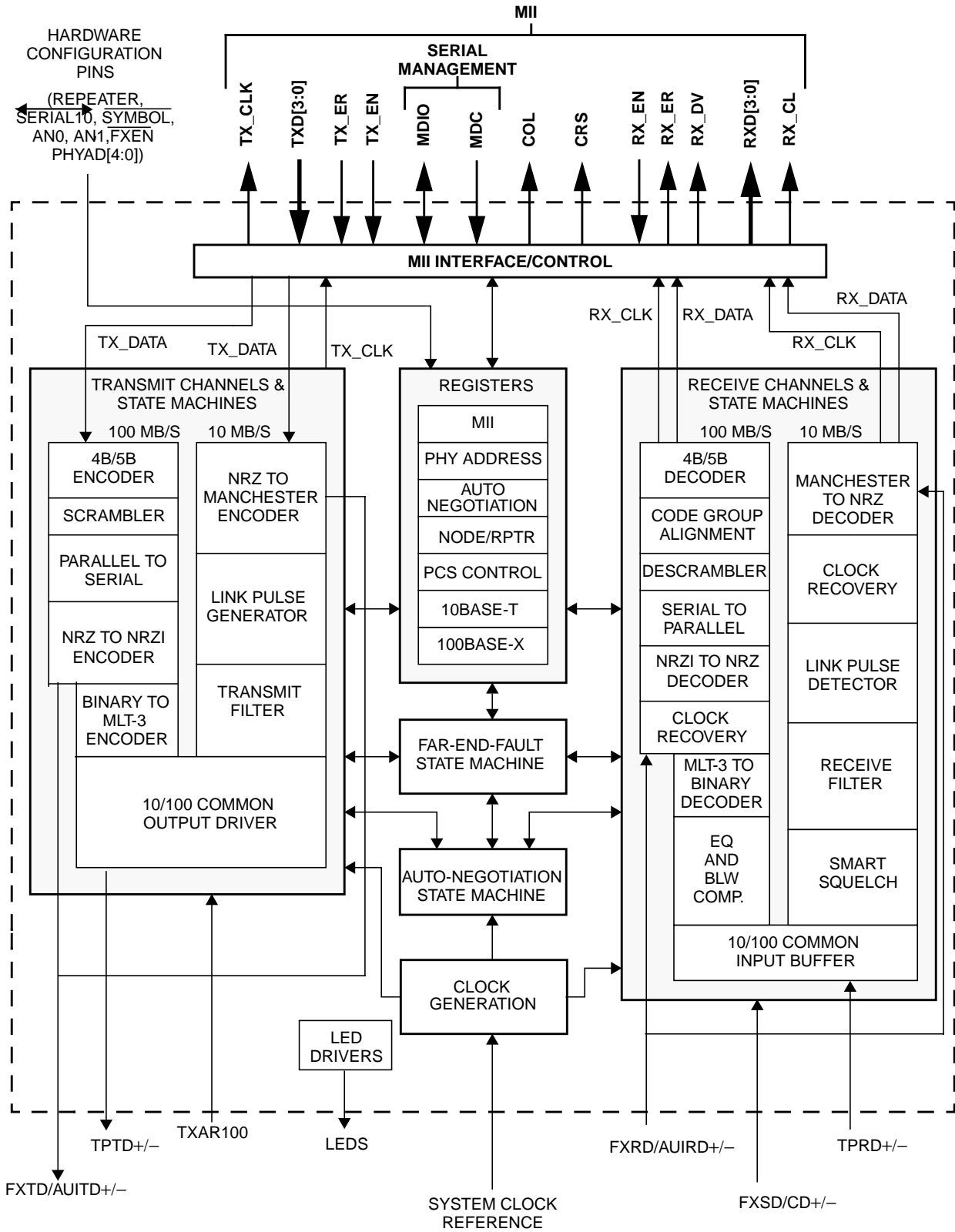
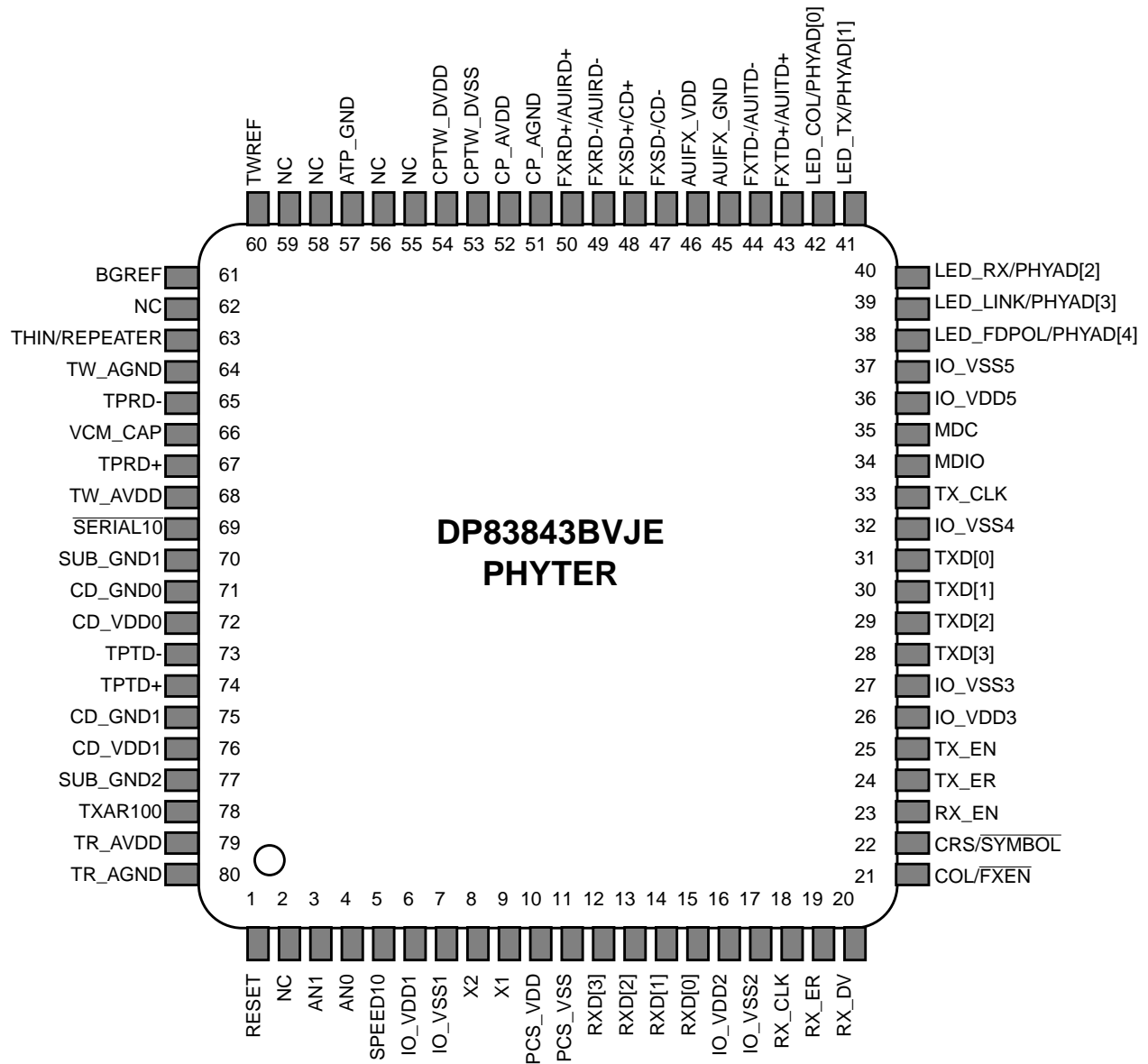

Table of Contents

1.0	Pin Descriptions	5	7.0	User Information	42
1.1	MII Interface	5	7.1	Link LED While in Force 100Mb/s Good Link	42
1.2	10 Mb/s and 100 Mb/s PMD Interface	6	7.2	False Link Indication When in Forced 10Mb/s	42
1.3	Clock Interface	8	7.3	10Mb/s Repeater Mode	42
1.4	Device Configuration Interface	8	7.4	Resistor Value Modifications	42
1.5	LED Interface	10	7.5	Magnetics	43
1.6	PHY Address Interface	11	7.6	Next Page Toggle Bit Initialization	43
1.7	Reset	11	7.7	Base Page to Next Page Initial FLP Burst Spacing	43
1.8	Power And Ground Pins	12			
1.9	Special Connect Pins	12	7.8	100Mb/s FLP Exchange Followed by Quiet	43
2.0	Functional Description	13	7.9	Common Mode Capacitor for EMI improvement	44
2.1	802.3u MII	13	7.10	BAD_SSD Event Lockup	44
2.2	100BASE-TX TRANSMITTER	15	8.0	Register Block	45
2.3	100BASE-TX RECEIVER	18	8.1	Register Definitions	45
2.4	10BASE-T TRANSCEIVER MODULE	22	9.0	Electrical Specifications	63
2.5	100 BASE-FX	24	9.1	DC Electrical Specification	64
2.6	AUI	26	9.2	CGM Clock Timing	66
3.0	Configuration	28	9.3	MII Serial Management AC Timing	66
3.1	Auto-Negotiation	28	9.4	100 Mb/s AC Timing	67
3.2	PHY Address and LEDs	30	9.5	10 Mb/s AC Timing	74
3.3	Half Duplex vs. Full Duplex	31	9.6	Auto-Negotiation Fast Link Pulse (FLP) Timing	80
3.4	100 Mb/s Symbol Mode	32	9.7	100BASE-X Clock Recovery Module (CRM) Timing	80
3.5	100BASE-FX Mode	32	9.8	Reset Timing	82
3.6	10 Mb/s Serial Mode	32	9.9	Loopback Timing	83
3.7	10 Mb/s AUI Mode	32	9.10	Isolation Timing	84
3.8	Repeater vs. Node	33	10.0	Test Conditions	85
3.9	Isolate Mode	33	10.1	FXTD/AUITD+/- Outputs (sourcing AUI levels)	85
3.10	Loopback	33	10.2	FXTD/AUITD+/- Outputs (sourcing PECL)	85
4.0	Clock Architecture	34	10.3	CMOS Outputs (MII and LED)	85
4.1	Clock Generation Module (CGM)	34	10.4	TPTD+/- Outputs (sourcing 10BASE-T)	85
4.2	100BASE-X Clock Recovery Module	36	10.5	TPTD+/- Outputs (sourcing 100BASE-TX)	85
4.3	10 Mb/s Clock Recovery Module	36	10.6	Idd Measurement Conditions	85
4.4	Reference Clock Connection Options	36	11.0	Package Dimensions inches (millimeters) unless otherwise noted	87
5.0	Reset Operation	37			
5.1	Power-up / Reset	37			
5.2	Hardware Reset	37			
5.3	Software Reset	37			
6.0	DP83843 Application	38			
6.1	Typical Node Application	38			
6.2	Power And Ground Filtering	38			
6.3	Power Plane Considerations	38			

Connection Diagram



**Order Number DP83843BVJE
NS Package Number VJE80**

1.0 Pin Descriptions

The DP83843 pins are classified into the following interface categories. Each interface is described in the sections that follow.

— MII INTERFACE

— 10/100 Mb/s PMD INTERFACE

— CLOCK INTERFACE

— DEVICE CONFIGURATION INTERFACE

— LED INTERFACE

— PHY ADDRESS INTERFACE

— RESET

— POWER AND GROUND PINS

— SPECIAL CONNECT PINS

1.1 MII Interface

Signal Name	Type	Pin #	Description
MDC	I	35	MANAGEMENT DATA CLOCK: Synchronous clock to the MDIO management data input/output serial interface which may be asynchronous to transmit and receive clocks. The maximum clock rate is 2.5 MHz. There is no minimum clock rate.
MDIO	I/O, Z	34	MANAGEMENT DATA I/O: Bi-directional management instruction/data signal that may be sourced by the station management entity or the PHY. This pin requires a 1.5 k Ω pulldown resistor.
CRS (SYMBOL)	I/O, Z	22	CARRIER SENSE: This pin is asserted high to indicate the presence of carrier due to receive or transmit activities in 10BASE-T or 100BASE-X Half Duplex modes. In Repeater or Full Duplex mode, this pin is asserted high to indicate the presence of carrier due only to receive activity. In Symbol mode this pin indicates the signal detect status of the TP-PMD (active high).
COL (FXEN)	I/O, Z	21	COLLISION DETECT: Asserted high to indicate detection of collision condition (assertion of CRS due to simultaneous transmit and receive activity) in 10 Mb/s and 100 Mb/s Half Duplex modes. While in 10BASE-T Half Duplex mode with Heartbeat enabled (bit 7, register 18h), this pin is also asserted for a duration of approximately 1 μ s at the end of transmission to indicate heartbeat (SQE test). During Repeater mode the heartbeat function is disabled. In Full Duplex mode, for 10 Mb/s or 100 Mb/s operation, this signal is always logic 0. There is no heartbeat function during 10 Mb/s full duplex operation.
TX_CLK	O, Z	33	TRANSMIT CLOCK: Transmit clock output from the DP83843: 25 MHz nibble transmit clock derived from Clock Generator Module's (CGM) PLL in 100BASE-TX mode. 2.5 MHz transmit clock in 10BASE-T Nibble mode. 10 MHz transmit clock in 10BASE-T Serial mode.
TXD[3] TXD[2] TXD[1] TXD[0]	I	28 29 30 31	TRANSMIT DATA: Transmit data MII input pins that accept nibble data during normal nibble-wide MII operation at either 2.5 MHz (10BASE-T mode) or 25 MHz (100BASE-X mode). In 10 Mb/s Serial mode, the TXD[0] pin is used as the serial data input pin, and TXD[3:1] are ignored.
TX_EN	I	25	TRANSMIT ENABLE: Active high input indicates the presence of valid nibble data on TXD[3:0] for both 100 Mb/s or 10 Mb/s nibble mode. In 10 Mb/s Serial mode, active high indicates the presence of valid 10 Mb/s data on TXD[0].
TX_ER (TXD[4])	I	24	TRANSMIT ERROR: In 100 Mb/s mode, when this signal is high and TX_EN is active the HALT symbol is substituted for the actual data nibble. In 10 Mb/s mode, this input is ignored. In Symbol mode ($\overline{\text{Symbol}}=0$), TX_ER becomes the TXD [4] pin which is the MSB for the transmit 5-bit data symbol.
RX_CLK	O, Z	18	RECEIVE CLOCK: Provides the recovered receive clock for different modes of operation: 25 MHz nibble clock in 100 Mb/s mode 2.5 MHz nibble clock in 10 Mb/s nibble mode 10 MHz receive clock in 10 Mb/s serial mode

1.0 Pin Descriptions (Continued)

Signal Name	Type	Pin #	Description
RXD[3] RXD[2] RXD[1] RXD[0]	O, Z	12 13 14 15	RECEIVE DATA: Nibble wide receive data (synchronous to RX_CLK, 25 MHz for 100BASE-X mode, 2.5 MHz for 10BASE-T nibble mode). Data is driven on the falling edge of RX_CLK. In 10 Mb/s serial mode, the RXD[0] pin is used as the data output pin which is also clocked out on the falling edge of RX_CLK. During 10 Mb/s serial mode RXD[3:1] pins become don't cares.
RX_EN	I	23	RECEIVE ENABLE: Active high enable for receive signals RXD[3:0], RX_CLK, RX_DV and RX_ER. A low on this input places these output pins in the TRI-STATE mode. For normal operation in a node or switch application, this pin should be pulled high. For operation in a repeater application, this pin may be connected to a repeater controller.
RX_ER (RXD[4])	O, Z	19	RECEIVE ERROR: Asserted high to indicate that an invalid symbol has been detected within a received packet in 100 Mb/s mode. In Symbol mode ($\overline{\text{Symbol}} = 0$), RX_ER becomes RXD[4] which is the MSB for the receive 5-bit data symbol.
RX_DV	O, Z	20	RECEIVE DATA VALID: Asserted high to indicate that valid data is present on RXD[3:0] for nibble mode and RXD[0] for serial mode. Data is driven on the falling edge of RX_CLK. This pin is not meaningful during Symbol mode.

1.2 10 Mb/s and 100 Mb/s PMD Interface

Signal Name	Type	Pin #	Description
TPTD- TPTD+	O (MLT-3 or 10BASE-T)	73 74	TRANSMIT DATA: Differential common output driver. This differential output is configurable to either 10BASE-T or 100BASE-TX signaling: 10BASE-T: Transmission of Manchester encoded 10BASE-T packet data as well as Link Pulses (including Fast Link Pulses for Auto-Negotiation purposes.) 100BASE-TX: Transmission of ANSI X3T12 compliant MLT-3 data. The DP83843 will automatically configure this common output driver for the proper signal type as a result of either forced configuration or Auto-Negotiation.
TPRD- TPRD+	I (MLT-3 or 10BASE-T)	65 67	RECEIVE DATA: Differential common input buffer. This differential input can be configured to accept either 100BASE-TX or 10BASE-T signaling: 10BASE-T: Reception of Manchester encoded 10BASE-T packet data as well as normal Link Pulses (including Fast Link Pulses for Auto-Negotiation purposes.) 100BASE-TX: Reception of ANSI X3T12 compliant scrambled MLT-3 data. The DP83843 will automatically configure this common input buffer to accept the proper signal type as a result of either forced configuration or Auto-Negotiation.
FXTD-/AUITD- FXTD+/AUITD+	O (PECL or AUI)	44 43	100BASE-FX or 10 Mb/s AUI TRANSMIT DATA: This configurable output driver supports either 125 Mb/s PECL, for 100BASE-FX applications, or 10 Mb/s AUI signaling. When configured as a 100BASE-FX transmitter this output sources 100BASE-FX standard compliant binary data for direct connection to an optical transceiver. This differential output is enabled only during 100BASE-FX device configuration (see pin definition for FXEN.) When configured as an AUI driver this output sources AUI compatible Manchester encoded data to support typical 10BASE2 or 10BASE5 products.

1.0 Pin Descriptions (Continued)

Signal Name	Type	Pin #	Description
FXRD-/AUIRD- FXRD+/AUIRD+	I (PECL or AUI)	49 50	<p>100BASE-FX or 10 Mb/s AUI RECEIVE DATA: This configurable input buffer supports either 125 Mb/s PECL, for 100BASE-FX applications, or 10 Mb/s AUI signaling.</p> <p>When configured as a 100BASE-FX receiver this input accepts 100BASE-FX standard compliant binary data direct from an optical transceiver. This differential input is enabled only during 100BASE-FX device configuration (see the pin definition for FXEN).</p> <p>When configured as an AUI buffer this input receives AUI compatible Manchester data to support typical 10BASE2 or 10BASE5 products.</p>
FXSD-/CD- FXSD+/CD+	I (PECL or AUI)	47 48	<p>SIGNAL DETECT or AUI COLLISION DETECT: This configurable input buffer supports either 125 Mb/s PECL, for 100BASE-FX applications, or 10 Mb/s AUI signaling.</p> <p>When configured as a 100BASE-FX receiver this input accepts indication from the 100BASE-FX PMD transceiver upon detection of a receive signal from the fiber media. This pin is only active during 100BASE-FX operation (see the pin definition for FXEN).</p> <p>When configured as an AUI buffer this input receives AUI compatible Manchester data to support typical 10BASE2 or 10BASE5 products.</p>
THIN (REPEATER)	I/O, Z	63	<p>THIN AUI MODE: This output allows for control of an external CTI coaxial transceiver connected through the AUI. This pin is controlled by writing to bit 3 of the 10BTSCR register (address 18h). The THIN pin may also be used as a user configurable output control pin.</p>
TXAR100	I (current reference)	78	<p>100 Mb/s TRANSMIT AMPLITUDE REFERENCE CONTROL: Reference current allowing adjustment of the TPTD+/- output amplitude during 100BASE-TX operation.</p> <p>By placing a resistor between this pin and ground or V_{CC}, a reference current is set up which dictates the output amplitude of the 100BASE-TX MLT-3 transmit signal. Connecting a resistor to V_{CC} will increase the transmit amplitude while connecting a resistor to ground will decrease the transmit amplitude. While the value of the resistor should be evaluated on a case by case bases, the DP83843 was designed to produce an amplitude close to the required range of 2V pk-pk differential $\pm 5\%$ as measured across TD+/- while driving a typical 100Ω differential load without a resistor connected to this pin. Therefore this pin is allowed to float in typical applications.</p> <p>This current reference is only recognized during 100BASE-TX operation and has no effect during 100BASE-FX, 10BASE-T, or AUI modes of operation.</p>
TWREF	I	60	<p>TWISTER REFERENCE RESISTOR: External reference current adjustment, via a resistor to TW_AGND, which controls the TP-PMD receiver equalization levels. The value of this resistor is 70k $\pm 1\%$.</p>
BGREF	I (current reference)	61	<p>BANDGAP REFERENCE: External current reference resistor for internal bandgap circuitry. The value of this resistor is 4.87k $\pm 1\%$.</p>
VCM_CAP	I	66	<p>COMMON MODE BYPASS CAPACITOR: External capacitor to improve common mode filtering for the receive signal. It is recommended that a .0033μF in parallel with a .10μF capacitor be used, see Figure 23.</p>

1.0 Pin Descriptions (Continued)

1.3 Clock Interface

Signal Name	Type	Pin #	Description
X1	I	9	CRYSTAL/OSCILLATOR INPUT: This pin is the primary clock reference input for the DP83843 and must be connected to a 25 MHz 0.005% (50 ppm) clock source. The DP83843 device supports either an external crystal resonator connected across pins X1 and X2, or an external CMOS-level oscillator source connected to pin X1 only. For 100 Mb/s repeater applications, X1 should be tied to the common 25 MHz transmit clock reference. Refer to section 4.4 for further detail relating to the clock requirements of the DP83843. Refer to section 4.0 for clock source specifications.
X2	O	8	CRYSTAL/OSCILLATOR OUTPUT PIN: This pin is used in conjunction with the X1 pin to connect to an external 25 MHz crystal resonator device. This pin must be left unconnected if an external CMOS oscillator clock source is utilized. For more information see the definition for pin X1. Refer to section 2.8 for further detail.

1.4 Device Configuration Interface

Signal Name	Type	Pin #	Description																																	
AN0	I (3-level)	4	<p>AN0: This is a three level input pin (1, M, 0) that works in conjunction with the AN1 pin to control the forced or advertised operating mode of the DP83843 according to the following table. The value on this pin is set by connecting the input pin to GND (0), V_{CC} (1), or leaving it unconnected (M.) The unconnected state, M, refers to the mid-level ($V_{CC}/2$) set by internal resistors. The value set at this input is latched into the DP83843 at power-up/reset.</p> <table border="0"> <thead> <tr> <th>AN1</th> <th>AN0</th> <th>Forced Mode</th> </tr> </thead> <tbody> <tr> <td>0</td> <td>M</td> <td>10BASE-T, Half-Duplex without Auto-Negotiation</td> </tr> <tr> <td>1</td> <td>M</td> <td>10BASE-T, Full Duplex without Auto-Negotiation</td> </tr> <tr> <td>M</td> <td>0</td> <td>100BASE-X, Half-Duplex without Auto-Negotiation</td> </tr> <tr> <td>M</td> <td>1</td> <td>100BASE-X, Full Duplex without Auto-Negotiation</td> </tr> </tbody> </table> <table border="0"> <thead> <tr> <th>AN1</th> <th>AN0</th> <th>Advertised Mode</th> </tr> </thead> <tbody> <tr> <td>M</td> <td>M</td> <td>All capable (i.e. Half-Duplex & Full Duplex for 10BASE-T and 100BASE-TX) advertised via Auto-Negotiation</td> </tr> <tr> <td>0</td> <td>0</td> <td>10BASE-T, Half-Duplex & Full Duplex advertised via Auto-Negotiation</td> </tr> <tr> <td>0</td> <td>1</td> <td>100BASE-TX, Half-Duplex & Full Duplex advertised via Auto-Negotiation</td> </tr> <tr> <td>1</td> <td>0</td> <td>10BASE-T & 100BASE-TX, Half-Duplex advertised via Auto-Negotiation</td> </tr> <tr> <td>1</td> <td>1</td> <td>10 BASE-T, Half-Duplex advertised via Auto-Negotiation</td> </tr> </tbody> </table>	AN1	AN0	Forced Mode	0	M	10BASE-T, Half-Duplex without Auto-Negotiation	1	M	10BASE-T, Full Duplex without Auto-Negotiation	M	0	100BASE-X, Half-Duplex without Auto-Negotiation	M	1	100BASE-X, Full Duplex without Auto-Negotiation	AN1	AN0	Advertised Mode	M	M	All capable (i.e. Half-Duplex & Full Duplex for 10BASE-T and 100BASE-TX) advertised via Auto-Negotiation	0	0	10BASE-T, Half-Duplex & Full Duplex advertised via Auto-Negotiation	0	1	100BASE-TX, Half-Duplex & Full Duplex advertised via Auto-Negotiation	1	0	10BASE-T & 100BASE-TX, Half-Duplex advertised via Auto-Negotiation	1	1	10 BASE-T, Half-Duplex advertised via Auto-Negotiation
AN1	AN0	Forced Mode																																		
0	M	10BASE-T, Half-Duplex without Auto-Negotiation																																		
1	M	10BASE-T, Full Duplex without Auto-Negotiation																																		
M	0	100BASE-X, Half-Duplex without Auto-Negotiation																																		
M	1	100BASE-X, Full Duplex without Auto-Negotiation																																		
AN1	AN0	Advertised Mode																																		
M	M	All capable (i.e. Half-Duplex & Full Duplex for 10BASE-T and 100BASE-TX) advertised via Auto-Negotiation																																		
0	0	10BASE-T, Half-Duplex & Full Duplex advertised via Auto-Negotiation																																		
0	1	100BASE-TX, Half-Duplex & Full Duplex advertised via Auto-Negotiation																																		
1	0	10BASE-T & 100BASE-TX, Half-Duplex advertised via Auto-Negotiation																																		
1	1	10 BASE-T, Half-Duplex advertised via Auto-Negotiation																																		
AN1	I (3-level)	3	<p>AN1: This is a three-level input pin (i.e., 1, M, 0) that works in conjunction with the AN0 pin to control the forced or advertised operating mode of the DP83843 according to the table given in the AN0 pin description above. The value on this pin is set by connecting the input pin to GND (0), V_{CC} (1), or leaving it unconnected (M.) The value at this input is latched into the DP83843 at power-up, hardware or software reset.</p>																																	

1.0 Pin Descriptions (Continued)

Signal Name	Type	Pin #	Description
REPEATER (THIN)	I/O	63	<p>REPEATER/NODE MODE: Selects 100 Mb/s Repeater mode when set high and node mode when set low. When set in Repeater mode the DP83843 only supports 100 Mb/s data rates. In Repeater mode (or Node mode with Full Duplex configured), the Carrier Sense (CRS) output from the DP83843 is asserted due to receive activity only. In Half Duplex Node mode, CRS is asserted due to either receive or transmit activity. During repeater mode the heartbeat function(SQE) is forced off.</p> <p>The Carrier Integrity Monitor (CIM) function is automatically enabled when this pin is set high (repeater mode) and disabled when this pin is set low (node mode) in order to facilitate 802.3u CIM requirements.</p> <p>There is an internal pullup resistor for this pin which is active during the power-up/reset period. If this pin is left floating externally, then the device will configure to 100 Mb/s Repeater mode as a result of power-up/reset. This pin must be externally pulled low (typically 10 kΩ) in order to configure the DP83843 for Node operation.</p> <p>The value of this input is latched into the DP83843 at power-up, hardware or software reset.</p>
SYMBOL/ (CRS)	I/O, Z	22	<p>SYMBOL MODE: This active low input allows 100 Mb/s transmit and receive data streams to bypass all of the transmit and receive operations when set low. Note that the PCS signals (CRS, RX_DV, RX_ER, and COL) have no meaning during this mode. During Symbol operation, pins RX_ER/RXD[4] and TX_ER/TXD[4] are used as the MSB of the 5 bit RX and TX data symbols.</p> <p>There is an internal pullup resistor for this pin which is active during the power-up/reset period. If this pin is left floating externally, then the device will configure to normal mode as a result of power-up/reset. This pin must be externally pulled low (typically 10 kΩ) in order to configure the DP83843 for Symbol mode operation.</p> <p>In Symbol mode this pin will indicate the signal detect status of the TP-PMD (active high).</p> <p>This mode has no effect on 10Mb/s operation. The value at this input is latched into the DP83843 at power-up, hardware or software reset.</p>
SERIAL10	I	69	<p>10BASE-T SERIAL/NIBBLE SELECT: With this active low input selected, transmit and receive data are exchanged serially at a 10 MHz clock rate on the least significant bits of the nibble-wide MII data buses, pins TXD[0] and RXD[0] respectively. This mode is intended for use with the DP83843 connected to a MAC using a 10 Mb/s serial interface. Serial operation is not supported in 100 Mb/s mode, therefore this input is ignored during 100 Mb/s operation.</p> <p>There is an internal pullup resistor for this pin which is active during the power-up/reset period. If this pin is left floating externally, then the device will configure to normal mode as a result of power-up/reset. This pin must be externally pulled low (typically 10 kΩ) in order to configure the DP83843 for Serial MII operation when running at 10 Mb/s.</p> <p>The value at this input is latched into the DP83843 at power-up, hardware or software reset.</p>
FXEN/ (COL)	I/O, Z	21	<p>FIBER ENABLE: This active low input allows 100 Mb/s transmit and receive data streams to bypass the scrambler and descrambler circuits when selected. All PCS signaling remains active and unaffected during this mode. During this mode, the internal 100 Mb/s transceiver is disabled, and NRZI data is transmitted and received via the FXTD/AUITD+/- and FXRD/AUIRD+/- pins.</p> <p>There is an internal pullup resistor for this pin which is active during the power-up/reset period. If this pin is left floating externally, then the device will configure to normal mode as a result of power-up/reset. This pin must be externally pulled low (typically 10 kΩ) in order to configure the DP83843 for 100BASE-FX operation.</p> <p>The value at this input is latched into the DP83843 at power-up, hardware or software reset.</p>

1.0 Pin Descriptions (Continued)

1.5 LED Interface

These outputs can be used to drive LEDs directly, or can be used to provide status information to a network management device. Refer to section 2.2 for a description of how to generate LED indication of 100 Mb/s mode. The active state of each LED output driver is dependent on the logic level sampled by the corresponding PHY address input upon power-up/reset. For example, if a given PHYAD

input is resistively pulled low then the corresponding LED output will be configured as an active high driver. Conversely, if a given PHYAD input is resistively pulled high then the corresponding LED output will be configured as an active low driver (refer to section 5.0.1 for further details). **Note that these outputs are standard CMOS voltage drivers and not open-drain.**

Signal Name	Type	Pin #	Description
LED_COL (PHYAD[0])	I/O	42	<p>COLLISION LED: Indicates the presence of collision activity for 10 Mb/s and 100 Mb/s Half Duplex operation. This LED has no meaning for 10 Mb/s or 100 Mb/s Full Duplex operation and will remain deasserted. During 10 Mb/s half duplex mode this pin will be asserted after data transmission due to the heartbeat function.</p> <p>The DP83843 incorporates a “monostable” function on the LED_COL output. This ensures that even collisions generate adequate LED ON time (approximately 50 ms) for visibility.</p>
LED_TX (PHYAD[1])	I/O	41	<p>TRANSMIT LED: Indicates the presence of transmit activity for 10 Mb/s and 100 Mb/s operation.</p> <p>If bit 7 (LED_Trans_MODE) of the PHYCTRL register (address 19h) is set high, then the LED_TX pin function is changed to indicate the status of the Disconnect function as defined by the state of bit 4 (CIM_STATUS) in the 100 Mb/s PCS configuration & status register (address 16h). See register definition for complete description of alternative operation.</p> <p>The DP83843 incorporates a “monostable” function on the LED_TX output. This ensures that even minimum size packets generate adequate LED ON time (approximately 50 ms) for visibility.</p>
LED_RX (PHYAD[2])	I/O	40	<p>RECEIVE LED: Indicates the presence of any receive activity for 10 Mb/s and 100 Mb/s operation. See register definitions(PHYCTRL register and PCSR register) for complete descriptions of alternative operation.</p> <p>The DP83843 incorporates a “monostable” function on the LED_RX output. This ensures that even minimum size packets generate adequate LED active time (approximately 50 ms) for visibility.</p>
LED_LINK (PHYAD[3])	I/O	39	<p>LINK LED: Indicates good link status for 10 Mb/s and 100 Mb/s operation.</p> <p>In 100BASE-T mode, link is established as a result of input receive amplitude compliant with TP-PMD specifications which will result in internal generation of Signal Detect as well as an internal signal from the Clock Recovery Module (cypher & sync). LED_LINK will assert after these internal signals have remained asserted for a minimum of 500µs. Once Link is established, then cipher & sync are no longer sampled and the Link will remain valid as long as Signal Detect is valid. LED_LINK will deassert immediately following the deassertion of the internal Signal Detect.</p> <p>10 Mb/s link is established as a result of the reception of at least seven consecutive normal Link Pulses or the reception of a valid 10BASE-T packet which will cause the assertion of LED_LINK. LED_LINK will deassert in accordance with the Link Loss Timer as specified in IEEE 802.3.</p> <p>In 100BASE-FX mode, link is established as a result of the assertion of the Signal detect input to the DP83843. LED_LINK will assert after Signal Detect has remained asserted for a minimum of 500µS. LED_LINK will deassert immediately following the deassertion of signal detect.</p> <p>The link function is disabled during AUI operation and LED_LINK is asserted.</p>
LED_FDPOL (PHYAD[4])	I/O	38	<p>FULL DUPLEX LED: Indicates Full Duplex mode status for 10 Mb/s or 100 Mb/s operation. This pin can be configured to indicate Polarity status for 10 Mb/s operation. If bit 6 (LED_DUP_MODE) in the PHYCTRL Register (address 19h) is deasserted, the LED_FDPOL pin function is changed to indicate Polarity status for 10 Mb/s operation.</p> <p>The DP83843 automatically compensates for 10BASE-T polarity inversion. 10BASE-T polarity inversion is indicated by the assertion of LED_FDPOL.</p>
SPEED10	O	5	<p>SPEED 10 Mb/s: Indicates 10 Mb/s operation when high. Indicates 100 Mb/s operation when low. This pin can be used to drive peripheral circuitry such as an LED indicator.</p>

1.0 Pin Descriptions (Continued)

1.6 PHY Address Interface

(00000) will result in a PHY isolation condition as a result of power-on/reset, as specified in IEEE 802.3u.

The DP83843 PHYAD[4:0] inputs provide up to 32 unique PHY address options. **An address selection of all zeros**

Signal Name	Type	Pin #	Description
PHYAD[0] (LED_COL)	I/O	42	PHY ADDRESS [0]: PHY address sensing pin for multiple PHY applications. PHY address sensing is achieved by strapping a pull-up/pull-down resistor (typically 10 k Ω) to this pin as required. The pull-up/pull-down status of this pin is latched into the PHYCTRL register (address 19h, bit 0) during power up/reset.
PHYAD[1] (LED_TX)	I/O	41	PHY ADDRESS [1]: PHY address sensing pin for multiple PHY applications. PHY address sensing is achieved by strapping a pull-up/pull-down resistor (typically 10 k Ω) to this pin as required. The pull-up/pull-down status of this pin is latched into the PHYCTRL register (address 19h, bit 1) during power up/reset.
PHYAD[2] (LED_RX)	I/O	40	PHY ADDRESS [2]: PHY address sensing pin for multiple PHY applications. PHY address sensing is achieved by strapping a pull-up/pull-down resistor (typically 10 k Ω) to this pin as required. The pull-up/pull-down status of this pin is latched into the PHYCTRL register (address 19h, bit 2) during power up/reset.
PHYAD[3] (LED_LINK)	I/O	39	PHY ADDRESS [3]: PHY address sensing pin for multiple PHY applications. PHY address sensing is achieved by strapping a pull-up/pull-down resistor (typically 10 k Ω) to this pin as required. The pull-up/pull-down status of this pin is latched into the PHYCTRL register (address 19h, bit 3) during power up/reset.
PHYAD[4] (LED_FDPOL)	I/O	38	PHY ADDRESS [4]: PHY address sensing pin for multiple PHY applications. PHY address sensing is achieved by strapping a pull-up/pull-down resistor (typically 10 k Ω) to this pin as required. The pull-up/pull-down status of this pin is latched into the PHYCTRL register (address 19h, bit 4) during power up/reset.

1.7 Reset

Signal Name	Type	Pin #	Description
RESET	I	1	RESET: Active high input that initializes or reinitializes the DP83843. Asserting this pin will force a reset process to occur which will result in all internal registers reinitializing to their default states as specified for each bit in section 7.0, and all strapping options are reinitialized. Refer to section 5.0 for further detail regarding reset.

1.0 Pin Descriptions (Continued)

1.8 Power And Ground Pins

The power (V_{CC}) and ground (GND) pins of the DP83843 are grouped in pairs into three categories--TTL/CMOS Input pairs, Transmit/Receive supply pairs, and Internal

supply pairs. This grouping allows for optimizing the layout and filtering of the power and ground supplies to this device.

Signal Name	Pin #	Description
TTL/CMOS INPUT/OUTPUT SUPPLY PAIRS		
IO_VDD1	6	TTL Input/Output Supply #1
IO_VSS1	7	
IO_VDD2	16	TTL Input/Output Supply #2
IO_VSS2	17	
IO_VDD3	26	TTL Input /Output Supply #3
IO_VSS3	27	
IO_VSS4	32	TTL Input/Output Supply #4
IO_VDD5	36	TTL Input/ Output Supply #5
IO_VSS5	37	
PCS_VDD	10	Physical Coding Sublayer Supply
PCS_VSS	11	
TRANSMIT/RECEIVE SUPPLY PAIRS		
AUIFX_VDD	46	AUI Power Supply
AUIFX_GND	45	
TR_AVDD	79	10 Mb/s Supply
TR_AGND	80	
TW_AVDD	68	100 Mb/s Power Supply
TW_AGND	64	
CD_VDD0	72	Common Driver Supply
CD_GND0	71	
CD_VDD1	76	Common Driver Supply
CD_GND1	75	
INTERNAL SUPPLY PAIRS		
CP_AVDD	52	CRM/CGM Supply
CP_AGND	51	
CPTW_DVDD	54	CRM/CGM Supply
CPTW_DVSS	53	
ATP_GND	57	100BASE-T PMD Supply
SUB_GND1,	70	100BASE-T PMD Supply
SUB_GND2	77	

1.9 Special Connect Pins

Signal Name	Type	Pin #	Description
NC		2,55,56, 58,59, 62	NO CONNECT: These pins are reserved for future use. Leave them unconnected (floating).

2.0 Functional Description

2.1 802.3u MII

The DP83843 incorporates the Media Independent Interface (MII) as specified in clause 22 of the IEEE 802.3u standard. This interface may be used to connect PHY devices to a 10/100 Mb/s MAC or a 100 Mb/s repeater controller. This section describes both the serial MII management interface as well as the nibble wide MII data interface.

The management interface of the MII allows the configuration and control of multiple PHY devices, the gathering of status and error information, and the determination of the type and abilities of the attached PHY(s).

The nibble wide MII data interface consists of a receive bus and a transmit bus each with control signals to facilitate data transfer between the PHY and the upper layer (MAC or repeater).

The DP83843 supports the TI ThunderLAN® MII interrupt function. For further information please contact your local National sales representative.

2.1.1 Serial Management Register Access

The serial MII specification defines a set of thirty-two 16-bit status and control registers that are accessible through the serial management data interface pins MDC and MDIO. The DP83843 implements all the required MII registers as well as several optional registers. These registers are fully described in Section 7. A description of the serial management access protocol follows.

2.1.2 Serial Management Access Protocol

The serial control interface consists of two pins, Management Data Clock (MDC) and Management Data Input/Output (MDIO). MDC has a maximum clock rate of 2.5 MHz

and no minimum rate. The MDIO line is bi-directional and may be shared by up to 32 devices. The MDIO frame format is shown in Table 1.

The MDIO pin requires a pull-up resistor (1.5 kΩ) which, during IDLE and turnaround, will pull MDIO high. In order to initialize the MDIO interface, the Station Management Entity (SME) sends a sequence of 32 contiguous logic ones on MDIO to provide the DP83843 with a sequence that can be used to establish synchronization. This preamble may be generated either by driving MDIO high for 32 consecutive MDC clock cycles, or by simply allowing the MDIO pull-up resistor to pull the MDIO pin high during which time 32 MDC clock cycles are provided. In addition 32 MDC clock cycles should be used if an invalid start, op code, or turnaround bit is detected.

The DP83843 waits until it has received this preamble sequence before responding to any other transaction. Once the DP83843 serial management port has initialized no further preamble sequencing is required until after a power-on/reset has occurred.

The Start code is indicated by a <01> pattern. This assures the MDIO line transitions from the default idle line state.

Turnaround is an idle bit time inserted between the Register Address field and the Data field. To avoid contention, no device actively drives the MDIO signal during the first bit of Turnaround during a read transaction. The addressed DP83843 drives the MDIO with a zero for the second bit of turnaround and follows this with the required data. Figure 2 shows the timing relationship between MDC and the MDIO as driven/received by the Station Management Entity and the DP83843 (PHY) for a typical register read access.

Table 1. Typical MDIO Frame Format

MII Management Serial Protocol	<idle><start><op code><device addr> <reg addr><turnaround><data><idle>
Read Operation	<idle><01><10><AAAAA> <RRRRR><Z0><xxxx xxxx xxxx xxxx><idle>
Write Operation	<idle><01><01><AAAAA> <RRRRR><10><xxxx xxxx xxxx xxxx><idle>

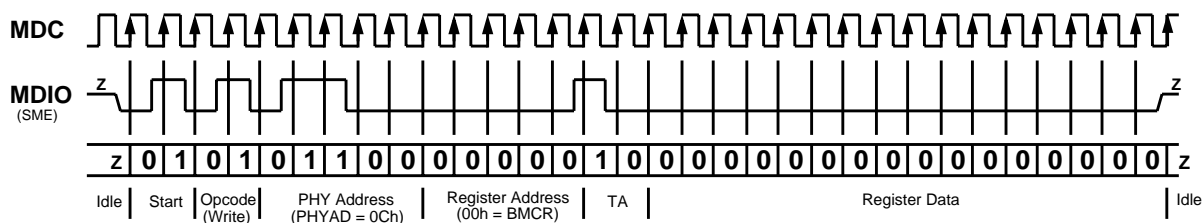

Figure 1. Typical MDC/MDIO Write Operation

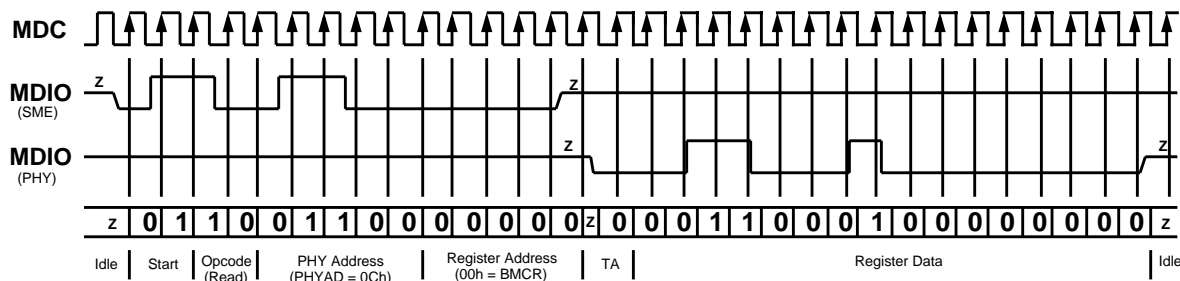

Figure 2. Typical MDC/MDIO Read Operation

2.0 Functional Description (Continued)

For write transactions, the Station Management Entity writes data to an addressed DP83843 eliminating the requirement for MDIO Turnaround. The Turnaround time is filled by the management entity inserting <10> for these two bits. Figure 1 shows the timing relationship for a typical MII register write access.

2.1.3 Preamble Suppression

The DP83843 supports a Preamble Suppression mode as indicated by a one in bit 6 of the Basic Mode Status Register (BMSR, address 01h). If the Station Management Entity (i.e. MAC or other management controller) determines that all PHYs in the system support Preamble Suppression by returning a one in this bit, then the Station Management Entity need not generate preamble for each management transaction.

The DP83843 requires a single initialization sequence of 32 bits of preamble following power-up/hardware reset. This requirement is generally met by the mandatory pull-up resistor on MDIO in conjunction with a continuous MDC, or the management access made to determine whether Preamble Suppression is supported.

While the DP83843 requires an initial preamble sequence of 32 bits for management initialization, it does not require a full 32 bit sequence between each subsequent transaction. A *minimum of one idle bit between management transactions is required* as specified in IEEE 802.3u.

2.1.4 PHY Address Sensing

The DP83843 can be set to respond to any of the possible 32 PHY addresses. Each DP83843 connected to a common serial MII must have a unique address. It should be noted that while an address selection of all zeros <00000> will result in PHY Isolate mode, this will not effect serial management access.

The DP83843 provides five PHY address pins, the state of which are latched into the PHYCTRL register (address 19h) at system power-up/reset. These pins are described in Section 2.8. For further detail relating to the latch-in timing requirements of the PHY address pins, as well as the other hardware configuration pins, refer to Section 3.10.

2.1.5 Nibble-wide MII Data Interface

Clause 22 of the IEEE 802.3u specification defines the Media Independent Interface. This interface includes a dedicated receive bus and a dedicated transmit bus. These two data buses, along with various control and indicate signals, allow for the simultaneous exchange of data between the DP83843 and the upper layer agent (MAC or repeater).

The receive interface consists of a nibble wide data bus RXD[3:0], a receive error signal RX_ER, a receive data valid flag RX_DV, and a receive clock RX_CLK for synchronous transfer of the data. The receive clock can operate at either 2.5 MHz to support 10 Mb/s operation modes or at 25 MHz to support 100 Mb/s operational modes.

The transmit interface consists of a nibble wide data bus TXD[3:0], a transmit error flag TX_ER, a transmit enable control signal TX_EN, and a transmit clock TX_CLK which runs at either 2.5 MHz or 25 MHz.

Additionally, the MII includes the carrier sense signal CRS, as well as a collision detect signal COL. The CRS signal asserts to indicate the reception of data from the network or as a function of transmit data in Half Duplex mode. The COL signal asserts as an indication of a collision which can

occur during half-duplex operation when both a transmit and receive operation occur simultaneously.

2.1.6 Collision Detect

For Half Duplex, a 10BASE-T or 100BASE-X collision is detected when the receive and transmit channels are active simultaneously. Collisions are reported by the COL signal on the MII.

If the DP83843 is transmitting in 10 Mb/s mode when a collision is detected, the collision is not reported until seven bits have been received while in the collision state. This prevents a collision being reported incorrectly due to noise on the network. The COL signal remains set for the duration of the collision.

If a collision occurs during a receive operation, it is immediately reported by the COL signal.

When heartbeat is enabled (only applicable to 10 Mb/s operation), approximately 1 μ s after the transmission of each packet, a Signal Quality Error (SQE) signal of approximately 10 bit times is generated (internally) to indicate successful transmission. SQE is reported as a pulse on the COL signal of the MII.

2.1.7 Carrier Sense

Carrier Sense (CRS) may be asserted due to receive activity, once valid data is detected via the Smart Squelch function during 10 Mb/s operation.

For 10 Mb/s Half Duplex operation, CRS is asserted during either packet transmission or reception.

For 10 Mb/s Full Duplex operation, CRS is asserted only due to receive activity.

CRS is deasserted following an end of packet.

In Repeater mode (pin 63/bit 9, register address 19h), CRS is only asserted due to receive activity.

2.1.8 MII Isolate Mode

A 100BASE-X PHY connected to the mechanical MII interface specified in IEEE 802.3u is required to have a default value of one in bit 10 of the Basic Mode Control Register (BMCR, address 00h). The DP83843 will set this bit to one if the PHY Address is set to 00000 upon power-up/hardware reset. Otherwise, the DP83843 will set this bit to zero upon power-up/hardware reset.

With bit 10 in the BMCR set to one, the DP83843 does not respond to packet data present at TXD[3:0], TX_EN, and TX_ER inputs and presents a high impedance on the TX_CLK, RX_CLK, RX_DV, RX_ER, RXD[3:0], COL, and CRS outputs. The DP83843 will continue to respond to all serial management transactions over the MII.

While in Isolate mode, the TPTD+/- and FXTD/AUITD+/- outputs are dependent on the current state of Auto-Negotiation. The DP83843 can Auto-Negotiate or parallel detect to a specific technology depending on the receive signal at the TPRD+/- inputs. A valid link can be established for either TPRD or FXRD/AUI even when the DP83843 is in Isolate mode.

It is recommended that the user have a basic understanding of clause 22 of the 802.3u standard.

2.0 Functional Description (Continued)

2.2 100BASE-TX TRANSMITTER

The 100BASE-TX transmitter consists of several functional blocks which convert synchronous 4-bit nibble data, as provided by the MII, to a scrambled MLT-3 125 Mb/s serial data stream. Because the 100BASE-TX TP-PMD is integrated, the differential output pins, TPTD+/-, can be directly routed to the AC coupling magnetics.

The block diagram in Figure 3 provides an overview of each functional block within the 100BASE-TX transmit section.

The Transmitter section consists of the following functional blocks:

- Code-group Encoder and Injection block (bypass option)
- Scrambler block (bypass option)
- NRZ to NRZI encoder block
- Binary to MLT-3 converter / Common Driver

The bypass option for the functional blocks within the 100BASE-X transmitter provides flexibility for applications such as 100 Mb/s repeaters where data conversion is not always required. The DP83843 implements the 100BASE-X transmit state machine diagram as specified in the IEEE 802.3u Standard, Clause 24.

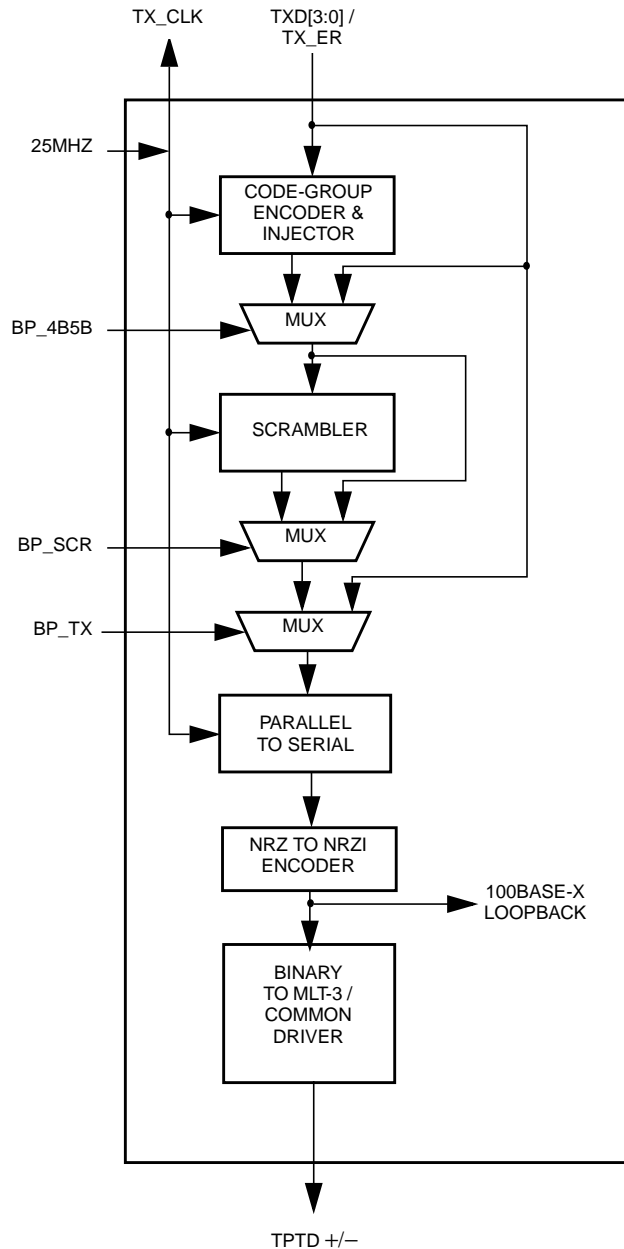

Figure 1. 100BASE-TX Transmit Block Diagram

- Code-group Encoding and Injection

2.0 Functional Description (Continued)

The code-group encoder converts 4 bit (4B) nibble data generated by the MAC into 5 bit (5B) code-groups for transmission. This conversion is required to allow control data to be combined with packet data code-groups. Refer to Table 2 for 4B to 5B code-group mapping details.

The code-group encoder substitutes the first 8 bits of the MAC preamble with a J/K code-group pair (11000 10001) upon transmit. The code-group encoder continues to replace subsequent 4B preamble and data nibbles with corresponding 5B code-groups. At the end of the transmit packet, upon the deassertion of Transmit Enable signal from the MAC or Repeater, the code-group encoder injects the T/R code-group pair (01101 00111) indicating the end of frame.

After the T/R code-group pair, the code-group encoder continuously injects IDLEs into the transmit data stream until the next transmit packet is detected (reassertion of Transmit Enable).

The DP83843 also incorporates a special injection function which allows for fixed transmission of special repeating patterns for testing purposes. These special patterns are not delimited with Start of Stream Delimiter (SSD) or End of Stream Delimiter (ESD) code-groups and should not be enabled during normal network connectivity.

These patterns, selectable via bits [8:7] of PCRS (address 16h), include:

8=0, 7=0: Normal operation (injection disabled)

8=0, 7=1: Transmit repeating FEFI pattern

8=1, 7=0: Transmit repeating 1.28 μ s period squarewave

8=1, 7=1: Transmit repeating 160 ns period squarewave

Note that these patterns will be routed through the transmit scrambler and become scrambled (and therefore potentially less useful) unless the scrambler is bypassed via bit 12 of LBR (address 17h). It should be noted that if the scrambler is bypassed by forcing the FXEN pin (and subsequently resetting the device) the TPTD+/- outputs will become disabled and the test pattern data will be routed to the FXTD/AUITD+/- outputs. Additionally, the test patterns will not be generated if the DP83843 is in symbol mode.

2.2.1 Scrambler

The scrambler is required to control the radiated emissions at the media connector and on the twisted pair cable (for 100BASE-TX applications). By scrambling the data, the total energy launched onto the cable is randomly distributed over a wide frequency range. Without the scrambler, energy levels at the PMD and on the cable could peak beyond FCC limitations at frequencies related to repeating 5B sequences (i.e., continuous transmission of IDLEs).

The scrambler is configured as a closed loop linear feedback shift register (LFSR) with an 11-bit polynomial. The output of the closed loop LFSR is combined with the NRZ 5B data from the code-group encoder via an X-OR logic function. The result is a scrambled data stream with sufficient randomization to decrease radiated emissions at certain frequencies by as much as 20 dB. The DP83843 uses the PHYID as determined by the PHYAD [4:0] pins to set a unique seed value for the scrambler so that the total energy produced by a multi-PHY application (i.e. repeater) distributes the energy out of phase across the spectrum and helps to reduce overall electro-magnetic radiation.

The scrambler is automatically bypassed when the DP83843 is placed in FXEN mode via hardware or, alternatively, controlled by bit 12 of LBR (address 17h) via software.

2.2.2 NRZ to NRZI Encoder

After the transmit data stream has been scrambled and serialized, the data must be NRZI encoded in order to comply with the TP-PMD standard for 100BASE-TX transmission over Category-5 unshielded twisted pair cable. There is no ability to bypass this block within the DP83843.

2.2.3 Binary to MLT-3 Convertor / Common Driver

The Binary to MLT-3 conversion is accomplished by converting the serial binary datastream output from the NRZI encoder into two binary data streams with alternately phased logic one events. These two binary streams are then fed to the twisted pair output driver which converts these streams to current sources and alternately drives either side of the transmit transformer primary winding resulting in a minimal current (20 mA max) MLT-3 signal. Refer to Figure 4 .

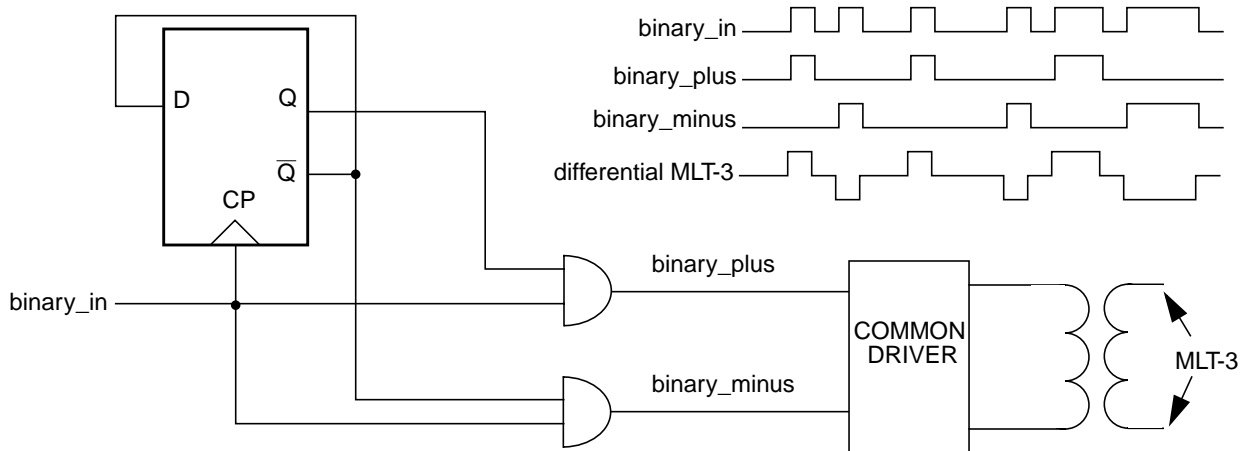

Figure 1. Binary to MLT-3 conversion

2.0 Functional Description (Continued)

Table 2. 4B5B Code-Group Encoding/Decoding

Name	PCS 5B Code-group	MII 4B Nibble Code
DATA CODES		
0	11110	0000
1	01001	0001
2	10100	0010
3	10101	0011
4	01010	0100
5	01011	0101
6	01110	0110
7	01111	0111
8	10010	1000
9	10011	1001
A	10110	1010
B	10111	1011
C	11010	1100
D	11011	1101
E	11100	1110
F	11101	1111
IDLE AND CONTROL CODES		
H	00100	Halt code-group - Error code
I	11111	Inter-Packet Idle - 0000 (Note 1)
J	11000	First Start of Packet - 0101 (Note 1)
K	10001	Second Start of Packet - 0101 (Note 1)
T	01101	First End of Packet - 0000 (Note 1)
R	00111	Second End of Packet - 0000 (Note 1)
INVALID CODES		
V	00000	0110 or 0101 (Note 2)
V	00001	0110 or 0101 (Note 2)
V	00010	0110 or 0101 (Note 2)
V	00011	0110 or 0101 (Note 2)
V	00101	0110 or 0101 (Note 2)
V	00110	0110 or 0101 (Note 2)
V	01000	0110 or 0101 (Note 2)
V	01100	0110 or 0101 (Note 2)
V	10000	0110 or 0101 (Note 2)
V	11001	0110 or 0101 (Note 2)

Note 1: Control code-groups I, J, K, T and R in data fields will be mapped as invalid codes, together with RX_ER asserted.

Note 2: Normally, invalid codes (V) are mapped to 6h on RXD[3:0] with RX_ER asserted. If the CODE_ERR bit in the PCS (bit 3, register address 16h) is set, the invalid codes are mapped to 5h on RXD[3:0] with RX_ER asserted. Refer to Section 4.14 for further detail.

2.0 Functional Description (Continued)

The 100BASE-TX MLT-3 signal sourced by the TPTD+/- common driver output pins is slow rate controlled. This should be considered when selecting AC coupling magnetics to ensure TP-PMD compliant transition times ($3 \text{ ns} < T_r < 5 \text{ ns}$).

The 100BASE-TX transmit TP-PMD function within the DP83843 is capable of sourcing only MLT-3 encoded data. Binary output from the TPTD+/- outputs is not possible in 100 Mb/s mode.

2.2.4 TX_ER

Assertion of the TX_ER input while the TX_EN input is also asserted will cause the DP83843 to substitute HALT code-groups for the 5B data present at TXD[3:0]. However, the SSD (/J/K/) and ESD (/T/R/) will not be substituted with Halt code-groups. As a result, the assertion of TX_ER while TX_EN is asserted will result in a frame properly encapsulated with the /J/K/ and /T/R/ delimiters which contains HALT code-groups in place of the data code-groups.

2.2.5 TXAR100

The transmit amplitude of the signal presented at the TPTD+/- output pins can be controlled by varying the value of resistance between TXAR100 and system GND. This TXAR100 resistor sets up a reference current that determines the final output current at TPTD+/-.

For 100Ω Category-5 UTP cable implementations, the TXAR100 resistor may be omitted as the DP83843 was designed to source a nominal 2V pk-pk differential transmit amplitude with this pin left floating. Setting the transmit amplitude to 2V pk-pk differential (MLT-3) as measured across the RJ45-8 transmit pins is critical for complying with the IEEE/ANSI TP-PMD specification of 2.0V pk-pk differential $\pm 5\%$.

2.3 100BASE-TX RECEIVER

The 100BASE-TX receiver consists of several functional blocks which convert the scrambled MLT-3 125 Mb/s serial data stream to synchronous 4-bit nibble data that is provided to the MII. Because the 100BASE-TX TP-PMD is integrated, the differential input pins, TPRD+/-, can be directly routed to the AC coupling magnetics.

See Figure 5 for a block diagram of the 100BASE-TX receive function. This provides an overview of each functional block within the 100BASE-TX receive section.

The Receive section consists of the following functional blocks:

- Input and BLW Compensation
- Signal Detect
- Digital Adaptive Equalization
- MLT-3 to Binary Decoder
- Clock Recovery Module
- NRZI to NRZ Decoder
- Serial to Parallel
- DESCRAMBLER (bypass option)
- Code Group Alignment
- 4B/5B Decoder (bypass option)
- Link Integrity Monitor
- Bad SSD Detection

The bypass option for the functional blocks within the 100BASE-X receiver provides flexibility for applications

such as 100 Mb/s repeaters where data conversion is not always required.

2.3.1 Input and Base Line Wander Compensation

Unlike the DP83223V TWISTER™, the DP83843 requires no external attenuation circuitry at its receive inputs, TPRD+/- . The DP83843 accepts TP-PMD compliant waveforms directly, requiring only a 100Ω termination plus a simple 1:1 transformer. The DP83843 also requires external capacitance to V_{CC} at the VCM_CAP pin (refer to Figure 23). This establishes a solid common mode voltage that is needed since the TPRD pins are used in both 10 Mb/s and 100 Mb/s modes.

The DP83843 is completely ANSI TP-PMD compliant because it compensates for baseline wander. The BLW compensation block can successfully recover the TP-PMD defined “killer” pattern and pass it to the digital adaptive equalization block.

Baseline wander can generally be defined as the change in the average DC content, over time, of an AC coupled digital transmission over a given transmission medium. (i.e. copper wire).

Baseline wander results from the interaction between the low frequency components of a bit stream being transmitted and the frequency response of the AC coupling component(s) within the transmission system. If the low frequency content of the digital bit stream goes below the low frequency pole of the AC coupling transformers then the droop characteristics of the transformers will dominate resulting in potentially serious baseline wander.

It is interesting to note that the probability of a baseline wander event serious enough to corrupt data is very low. In fact, it is reasonable to virtually bound the occurrence of a baseline wander event serious enough to cause bit errors to a legal but premeditated, artificially constructed bit sequence loaded into the original MAC frame. Several studies have been conducted to evaluate the probability of various baseline wander events for FDDI transmission over copper. Contact the X3.263 ANSI group for further information.

2.3.2 Signal Detect

The signal detect function of the DP83843 is incorporated to meet the specifications mandated by the ANSI FDDI TP-PMD Standard as well as the IEEE 802.3 100BASE-TX Standard for both voltage thresholds and timing parameters.

Note that the reception of Normal 10BASE-T link pulses and fast link pulses per IEEE 802.3u Auto-Negotiation by the 100BASE-X receiver do not cause the DP83843 to assert signal detect.

While signal detect is normally generated and processed entirely within the DP83843, it can be observed directly on the CRS pin (pin 22) while the DP83843 is configured for Symbol mode. Refer to Section 3.4 for further detail regarding Symbol mode operation.

2.3.3 Digital Adaptive Equalization

When transmitting data at high speeds over copper twisted pair cable, frequency dependent attenuation becomes a concern. In high speed twisted pair signalling, the frequency content of the transmitted signal can vary greatly during normal operation based primarily on the randomness of the scrambled data stream. This variation in signal

2.0 Functional Description (Continued)

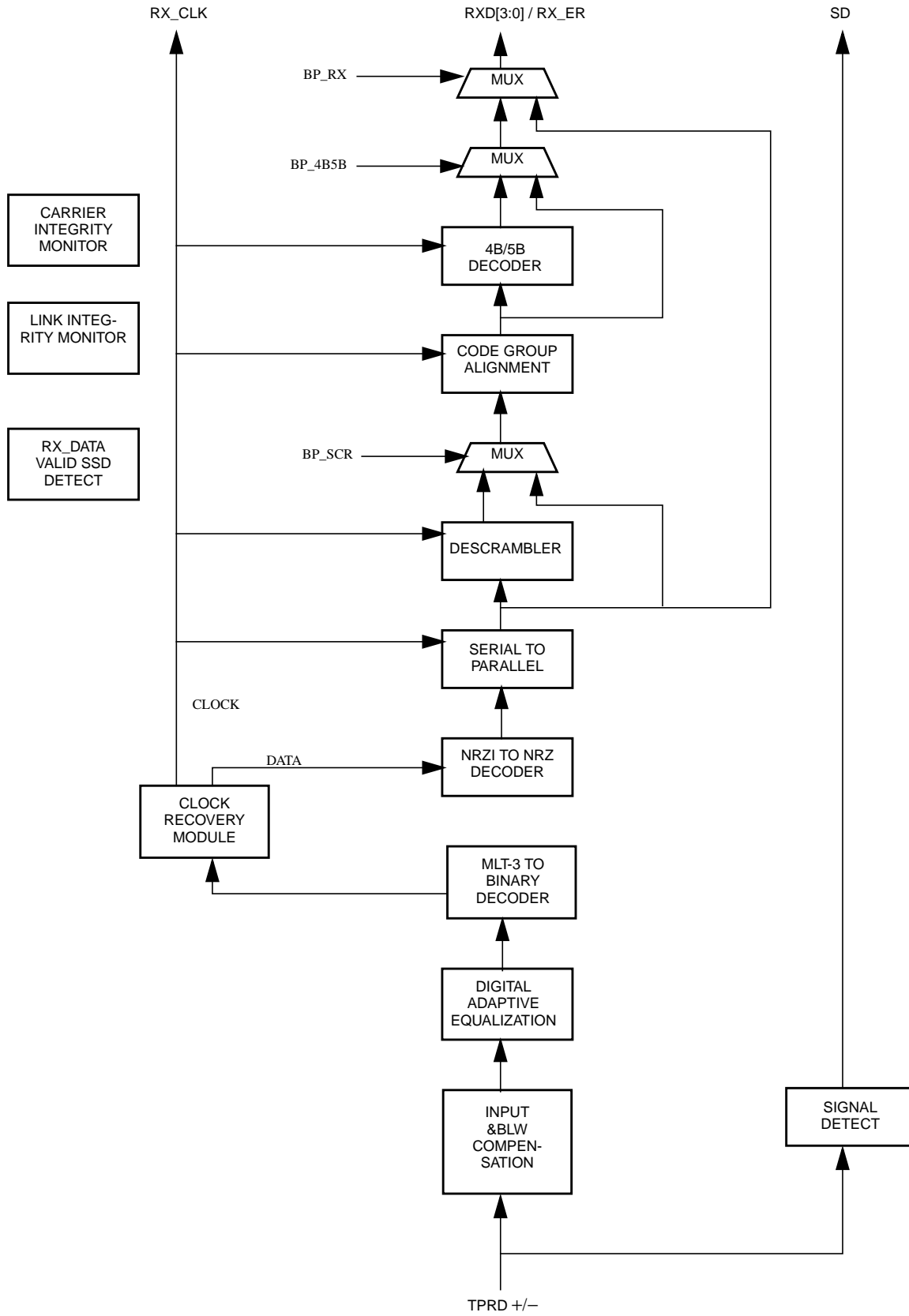

Figure 1. Receive Block Diagram

2.0 Functional Description (Continued)

attenuation caused by frequency variations must be compensated for to ensure the integrity of the transmission.

In order to ensure quality transmission when employing MLT-3 encoding, the compensation must be able to adapt to various cable lengths and cable types depending on the installed environment. The selection of long cable lengths for a given implementation, requires significant compensation which will over-compensate for shorter, less attenuating lengths. Conversely, the selection of short or intermediate cable lengths requiring less compensation will cause serious under-compensation for longer length cables. Therefore, the compensation or equalization must be adaptive to ensure proper conditioning of the received signal independent of the cable length.

The DP83843 utilizes an extremely robust equalization scheme referred to herein as 'Digital Adaptive Equalization.' Existing designs use an adaptive equalization scheme that determines the approximate cable length by monitoring signal attenuation at certain frequencies. This attenuation value was compared to the internal receive input reference voltage. This comparison would indicate that amount of equalization to use. Although this scheme is used successfully on the DP83223V TWISTER, it is sensitive to transformer mismatch, resistor variation and process induced offset. The DP83223V also required an external attenuation network to help match the incoming signal amplitude to the internal reference.

Digital Adaptive Equalization is based on an advanced digitally controlled signal tracking technique. This method uses peak tracking with digital over-sampling and digitally controlled feedback loops to regenerate the receive signal. This technique does not depend on input amplitude variations to set the equalization factor. As a result it maintains constant jitter performance for any cable length up to 150 meters of CAT-5. Digital Adaptive Equalization allows for very high tolerance to signal amplitude variations.

The curves given in Figure 6 illustrate attenuation at certain frequencies for given cable lengths. This is derived from the worst case frequency vs. attenuation figures as specified in the EIA/TIA Bulletin TSB-36. These curves indicate the significant variations in signal attenuation that must be compensated for by the receive adaptive equalization circuit.

Figure 7 represents a scrambled IDLE transmitted over zero meters of cable as measured at the AII (Active Input Interface) of the receiver. Figure 8 and Figure 9 represent the signal degradation over 50 and 100 Meters of CAT-5 cable respectively, also measured at the AII. These plots show the extreme degradation of signal integrity and indicate the requirement for a robust adaptive equalizer.

The DP83843 provides the added flexibility of controlling the type of receive equalization required for a given implementation. This is done through TW_EQSEL (bits [13:12] of the PHYCTRL register, address 19h). While digital adaptive equalization is the preferred method of cable compensation for 100BASE-TX, the ability to switch the equalizer completely off or to a fixed maximum is provided. This feature is intended as a test mode only and, if enabled, will inhibit normal performance of the DP83843.

2.3.4 MLT-3 to NRZI Decoder

The DP83843 decodes the MLT-3 information from the Digital Adaptive Equalizer block to binary NRZI data. The relationship of binary to MLT-3 data is shown in Figure 4.

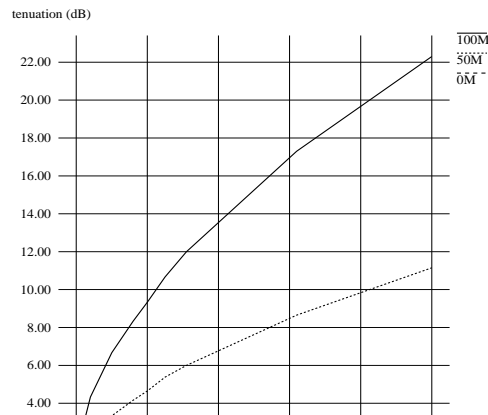

Figure 1. EIA/TIA Attenuation vs Frequency for 0, 50, 100 meters of CAT-5 cable

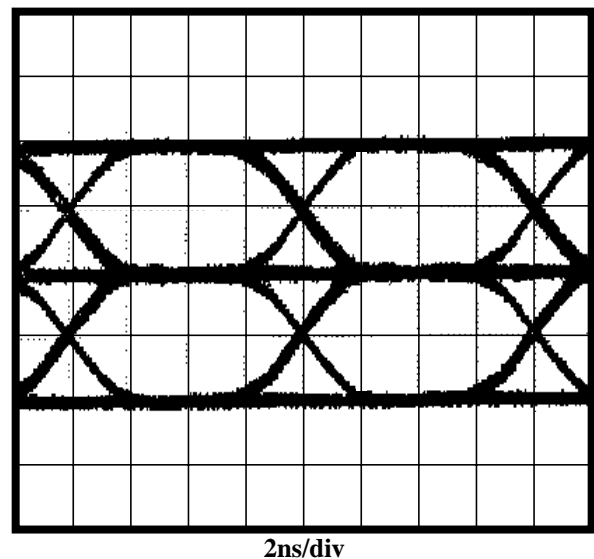

Figure 2. MLT-3 Signal Measured at AII after 0 meters of CAT-5 cable

2.3.5 Clock Recovery Module

The Clock Recovery Module (CRM) accepts 125 Mb/s NRZI data from the MLT-3 to NRZI decoder. The CRM locks onto the 125 Mb/s data stream and extracts a 125 MHz reference clock. The extracted and synchronized clock and data are used as required by the synchronous receive operations as generally depicted in Figure 5.

The CRM is implemented using an advanced digital Phase Locked Loop (PLL) architecture that replaces sensitive analog circuits. Using digital PLL circuitry allows the DP83843 to be manufactured and specified to tighter tolerances.

For further information relating to the 100BASE-X clock recovery module, refer to Section 4.3.

2.0 Functional Description (Continued)

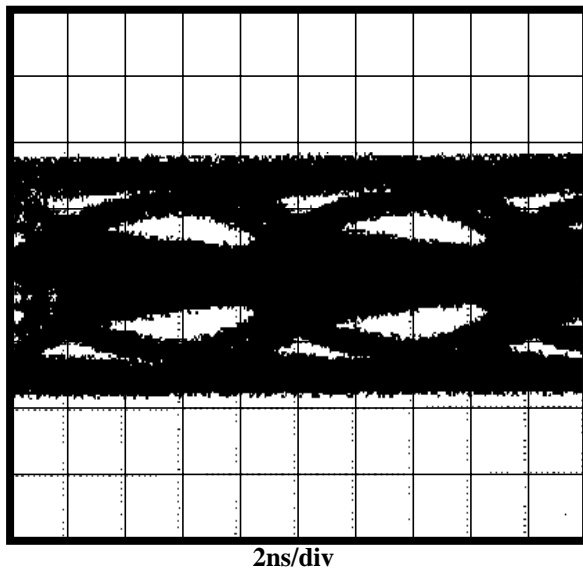

Figure 1. MLT-3 Signal Measured at All after 50 meters of CAT-5 cable

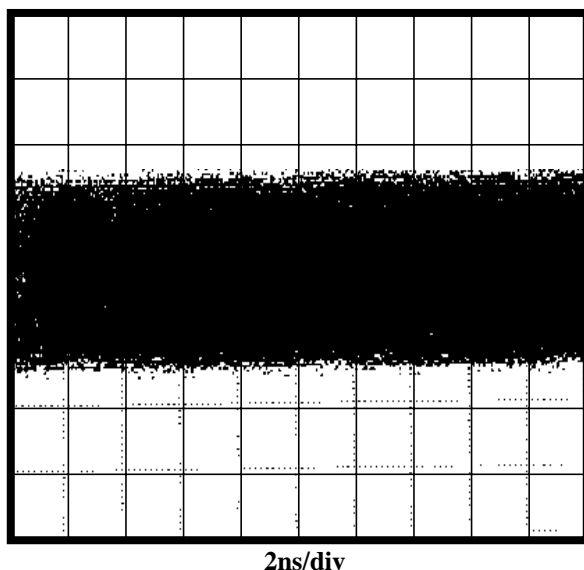

Figure 2. MLT-3 Signal Measured at All after 100 meters of CAT-5 cable

2.3.6 NRZI to NRZ

In a typical application, the NRZI to NRZ decoder is required in order to present NRZ formatted data to the descrambler (or to the code-group alignment block, if the descrambler is bypassed, or directly to the PCS, if the receiver is bypassed).

The receive data stream is in NRZI format, therefore, the data must be decoded to NRZ before further processing.

2.3.7 Serial to Parallel

The 100BASE-X receiver includes a Serial to Parallel converter which supplies 5 bit wide data symbols to the Descrambler. Converting to parallel helps to decrease latency through the device, as well as performing the

required function for ultimately providing data to the nibble-wide interface of the MII.

2.3.8 Descrambler

A 5-bit parallel (code-group wide) descrambler is used to descramble the receive NRZ data. To reverse the data scrambling process, the descrambler has to generate an identical data scrambling sequence (N) in order to recover the original unscrambled data (UD) from the scrambled data (SD) as represented in the equations:

$$SD = (UD \oplus N)$$

$$UD = (SD \oplus N)$$

Synchronization of the descrambler to the original scrambling sequence (N) is achieved based on the knowledge that the incoming scrambled data stream consists of scrambled IDLE data. After the descrambler has recognized 12 consecutive IDLE code-groups, where an IDLE code-group in 5B NRZ is equal to five consecutive ones (11111), it will synchronize to the receive data stream and generate unscrambled data in the form of unaligned 5B code-groups.

In order to maintain synchronization, the descrambler must continuously monitor the validity of the unscrambled data that it generates. To ensure this, a line state monitor and a hold timer are used to constantly monitor the synchronization status. Upon synchronization of the descrambler the hold timer starts a 722 μ s countdown. Upon detection of sufficient IDLE code-groups within the 722 μ s period, the hold timer will reset and begin a new countdown. This monitoring operation will continue indefinitely given a properly operating network connection with good signal integrity. If the line state monitor does not recognize sufficient unscrambled IDLE code-groups within the 722 μ s period, the entire descrambler will be forced out of the current state of synchronization and reset in order to re-acquire synchronization.

The value of the time-out for this timer may be modified from 722 μ s to 2 ms by setting bit 12 of the PCSR (address 16h) to one. The 2 ms option allows applications with Maximum Transmission Units (packet sizes) larger than IEEE 802.3 specifications to maintain descrambler synchronization (i.e. switch or router applications).

Additionally, this timer may be disabled entirely by setting bit 11 of the PCSR (address 16h) to one. The disabling of the time-out timer is not recommended as this will eventually result in a lack of synchronization between the transmit scrambler and the receive descrambler which will corrupt data. The descrambler time-out counter may be reset by bit 13 of the PCSR.

2.3.9 Code-group Alignment

The code-group alignment module operates on unaligned 5-bit data from the descrambler (or, if the descrambler is bypassed, directly from the NRZI/NRZ decoder) and converts it into 5B code-group data (5 bits). Code-group alignment occurs after the J/K code-group pair is detected. Once the J/K code-group pair (11000 10001) is detected, subsequent data is aligned on a fixed boundary.

2.3.10 4B/5B Decoder

The code-group decoder functions as a look up table that translates incoming 5B code-groups into 4B nibbles. The code-group decoder first detects the J/K code-group pair preceded by IDLE code-groups and replaces the J/K with

2.0 Functional Description (Continued)

the MAC preamble. Specifically, the J/K 10-bit code-group pair is replaced by the nibble pair (0101 0101). All subsequent 5B code-groups are converted to the corresponding 4B nibbles for the duration of the entire packet. This conversion ceases upon the detection of the T/R code-group pair denoting the End of Stream Delimiter (ESD) or with the reception of a minimum of two IDLE code-groups.

2.3.11 100BASE-X Link Integrity Monitor

The 100BASE-X Link Integrity Monitor function (LIM) allows the receiver to ensure that reliable data is being received. Without reliable data reception, the LIM will halt both transmit and receive operations until such time that a valid link is detected (i.e. good link).

If Auto-Negotiation is not enabled, then a valid link will be indicated once SD+/- is asserted continuously for 500 μ s.

If Auto-Negotiation is enabled, then Auto-Negotiation will further qualify a valid link as follows:

- The descrambler must receive a minimum of 12 IDLE code groups for proper link initialization.
- The Auto-Negotiation must determine that the 100BASE-X function should be enabled.

A valid link for a non-Auto-Negotiating application is indicated by either the Link LED output or by reading bit 2 of the Basic Mode Status Register BMSR (address 01h). For a truly qualified valid link indication as a result of Auto-Negotiation, bit 2 of the BMSR register (address 01h) must be read.

2.3.12 Bad SSD Detection

A Bad Start of Stream Delimiter (Bad SSD) is any transition from consecutive idle code-groups to non-idle code-groups which is not prefixed by the code-group pair /J/K.

If this condition is detected, the DP83843 will assert RX_ER and present RXD[3:0] = 1110 to the MII for the cycles that correspond to received 5B code-groups. In order to exit this state the PHYTER must receive at least two IDLE code groups and the PHYTER cannot receive a single IDLE code group at any time. In addition, the False Carrier Event Counter (address 14h) will be incremented by one. Once the PHYTER exits this state, RX_ER and CRS become de-asserted.

When bit 11 of the LBR register is one (BP_RX), RXD[3:0] and RX_ER/RXD[4] are not modified.

2.3.13 Carrier Integrity Monitor

The Carrier Integrity Monitor function (CIM) protects the repeater from transient conditions that would otherwise cause spurious transmission due to a faulty link. This function is required for repeater applications and is not specified for node applications.

The REPEATER pin (pin 63) determines the default state of bit 5 of the PCS register (Carrier Integrity Monitor Disable, address 16h) to automatically enable or disable the CIM function as required for IEEE 802.3 compliant applications. After power-up/reset, software may enable or disable this function independent of Repeater or Node mode.

If the CIM determines that the link is unstable, the DP83843 will not propagate the received data or control signaling to the MII and will ignore data transmitted via the MII. The DP83843 will continue to monitor the receive stream for valid carrier events.

Detection of an unstable link condition will cause bit 4 of the PCS register (address 16h) to be set to one. This bit is cleared to zero upon a read operation once a stable link condition is detected by the CIM. Upon detection of a stable link, the DP83843 will resume normal operations.

The Disconnect Counter (address 13h) increments each time the CIM determines that the link is unstable.

2.4 10BASE-T TRANSCEIVER MODULE

The 10BASE-T Transceiver Module is IEEE 802.3 compliant. It includes the receiver, transmitter, collision, heartbeat, loopback, jabber, and link integrity functions, as defined in the standard. An external filter is not required on the 10BASE-T interface since this is integrated inside the DP83843. Due to the complexity and scope of the 10BASE-T Transceiver block and various sub-blocks, this section focuses on the general system level operation.

2.4.1 Operational Modes

The DP83843 has 2 basic 10BASE-T operational modes:

- Half Duplex mode
- Full Duplex mode

Half Duplex Mode

In Half Duplex mode the DP83843 functions as a standard IEEE 802.3 10BASE-T transceiver supporting the CSMA/CD protocol.

Full Duplex Mode

In Full Duplex mode the DP83843 is capable of simultaneously transmitting and receiving without asserting the collision signal. The DP83843's 10 Mb/s ENDEC is designed to encode and decode simultaneously.

2.4.2 Oscillator Module Operation

A 25 MHz crystal or can-oscillator with the following specifications is recommended for driving the X1 input.

1. CMOS output with a 50ppm frequency tolerance.
2. 35-65% duty cycle (max).
3. Two TTL load output drive.

Additional output drive may be necessary if the oscillator must also drive other components. When using a clock oscillator it is still recommended that the designer connect the oscillator output to the X1 pin and leave X2 floating.

2.4.3 Smart Squelch

The smart squelch is responsible for determining when valid data is present on the differential receive inputs (TPRD+/-). The DP83843 implements an intelligent receive squelch to ensure that impulse noise on the receive inputs will not be mistaken for a valid signal. Smart squelch operation is independent of the 10BASE-T operational mode.

The squelch circuitry employs a combination of amplitude and timing measurements (as specified in the IEEE 802.3 10BASE-T standard) to determine the validity of data on the twisted pair inputs (refer to Figure 10).

The signal at the start of packet is checked by the smart squelch and any pulses not exceeding the squelch level (either positive or negative, depending upon polarity) will be rejected. Once this first squelch level is overcome correctly, the opposite squelch level must then be exceeded within 150 ns. Finally the signal must exceed the original squelch level within a further 150 ns to ensure that the

2.0 Functional Description (Continued)

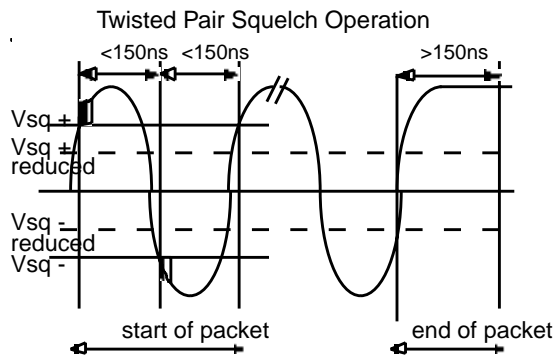

Figure 1. 10BASE-T Twisted Pair Smart Squelch Operation

input waveform will not be rejected. The checking procedure results in the loss of typically three preamble bits at the beginning of each packet.

Only after all these conditions have been satisfied will a control signal be generated to indicate to the remainder of the circuitry that valid data is present. At this time, the smart squelch circuitry is reset.

Valid data is considered to be present until squelch level has not been generated for a time longer than 150ns, indicating the End of Packet. Once good data has been detected the squelch levels are reduced to minimize the effect of noise causing premature End of Packet detection.

The receive squelch threshold level can be lowered for use in longer cable applications. This is achieved by setting the LS_SEL bit in the 10BTSCR (bit 6, register 18h). Collision Detection

For Half Duplex, a 10BASE-T collision is detected when the receive and transmit channels are active simultaneously. Collisions are reported by the COL signal on the MII.

If the ENDEC is transmitting when a collision is detected, the collision is not reported until seven bits have been received while in the collision state. This prevents a collision being reported incorrectly due to noise on the network. The COL signal remains set for the duration of the collision. If the ENDEC is receiving when a collision is detected it is reported immediately (through the COL).

When heartbeat is enabled, approximately 1 μ s after the transmission of each packet, a Signal Quality Error (SQE) signal of approximately 10 bit times is generated (internally) to indicate successful transmission. SQE is reported as a pulse on the COL signal of the MII.

2.4.4 Carrier Sense

Carrier Sense (CRS) may be asserted due to receive activity once valid data is detected via the smart squelch function.

For 10 Mb/s Half Duplex operation, CRS is asserted during either packet transmission or reception.

For 10 Mb/s Full Duplex operation, CRS is asserted only due to receive activity.

CRS is deasserted following an end of packet.

In Repeater mode, CRS is only asserted due to receive activity.

2.4.5 Normal Link Pulse Detection/Generation

The link pulse generator produces pulses as defined in the IEEE 802.3 10BASE-T standard. Each link pulse is nominally 100 ns in duration and is transmitted every 16 ms \pm 8 ms, in the absence of transmit data.

Link pulse is used to check the integrity of the connection with the remote end. If valid link pulses are not received, the link detector disables the 10BASE-T twisted pair transmitter, receiver and collision detection functions.

When the link integrity function is disabled, the 10BASE-T transceiver will operate regardless of the presence of link pulses.

2.4.6 Jabber Function

The jabber function monitors the DP83843's output and disables the transmitter if it attempts to transmit a packet of longer than legal size. A jabber timer monitors the transmitter and disables the transmission if the transmitter is active for approximately 20-30 ms.

Once disabled by the Jabber function, the transmitter stays disabled for the entire time that the ENDEC module's internal transmit enable is asserted. This signal has to be deasserted for approximately 400-600 ms (the "unjab" time) before the Jabber function re-enables the transmit outputs.

The Jabber function is only meaningful in 10BASE-T mode.

2.4.7 Status Information

10BASE-T Status Information is available on the LED output pins of the DP83843. Transmit activity, receive activity, link status, link polarity and collision activity information is output to the five LED output pins (LED_RX, LED_TX, LED_LINK, LED_FDPOL, and LED_COL). Additionally, the active high SPEED10 output will assert to indicate 10 Mb/s operation.

If required, the LED outputs can be used to provide digital status information to external circuitry.

The link LED output indicates good link status for both 10 and 100 Mb/s modes. In Half Duplex 10BASE-T mode, LED_LINK indicates link status.

The link integrity function can be disabled. When disabled, the transceiver will operate regardless of the presence of link pulses and the link LED will stay asserted continuously.

2.4.8 Automatic Link Polarity Detection

The DP83843's 10BASE-T transceiver module incorporates an automatic link polarity detection circuit. When seven consecutive link pulses or three consecutive receive

2.0 Functional Description (Continued)

packets with inverted End-of-Packet pulses are received, bad polarity is reported.

A polarity reversal can be caused by a wiring error at either end of the cable, usually at the Main Distribution Frame (MDF) or patch panel in the wiring closet.

The bad polarity condition is latched and the LED_FDPOL output is asserted. The DP83843's 10BASE-T transceiver module corrects for this error internally and will continue to decode received data correctly. This eliminates the need to correct the wiring error immediately.

2.4.9 10BASE-T Internal Loopback

When the 10MB_ENDEC_LB bit in the LBR (bit 4, register address 17h) is set, 10BASE-T transmit data is looped back in the ENDEC to the receive channel. The transmit drivers and receive input circuitry are disabled in transceiver loopback mode, isolating the transceiver from the network.

Loopback is used for diagnostic testing of the data path through the transceiver without transmitting on the network or being interrupted by receive traffic. This loopback function causes the data to loopback just prior to the 10BASE-T output driver buffers such that the entire transceiver path is tested.

2.4.10 Transmit and Receive Filtering

External 10BASE-T filters are not required when using the DP83843 as the required signal conditioning is integrated.

Only isolation/step-up transformers and impedance matching resistors are required for the 10BASE-T transmit and receive interface. The internal transmit filtering ensures that all the harmonics in the transmit signal are attenuated by at least 30 dB.

2.4.11 Encoder/Decoder (ENDEC) Module

The ENDEC module consists of essentially four functions:

The oscillator generates the 10 MHz transmit clock signal for system timing from an external 25 MHz oscillator.

The Manchester encoder accepts NRZ data from the controller or repeater, encodes the data to Manchester, and transmits it differentially to the transceiver, through the differential transmit driver.

The Manchester decoder receives Manchester data from the transceiver, converts it to NRZ data and recovers clock pulses for synchronous data transfer to the controller or repeater.

The collision monitor indicates to the controller the presence of a valid 10 Mb/s collision signal.

2.4.12 Manchester Encoder

The encoder begins operation when the Transmit Enable input (TX_EN) goes high and converts the NRZ data to pre-emphasized Manchester data for the transceiver. For the duration of TX_EN remaining high, the Transmit Data (TPTD+/-) is encoded for the transmit-driver pair (TPTD+/-). TXD must be valid on the rising edge of Transmit Clock (TX_CLK). Transmission ends when TX_EN deasserts. The last transition is always positive; it occurs at the center of the bit cell if the last bit is a one, or at the end of the bit cell if the last bit is a zero.

2.4.13 Manchester Decoder

The decoder consists of a differential receiver and a PLL to separate a Manchester encoded data stream into internal clock signals and data. The differential input must be externally terminated with either a differential 100ohm termination network to accommodate UTP cable.

The decoder detects the end of a frame when no more mid-bit transitions are detected. Within one and a half bit times after the last bit, carrier sense is de-asserted. Receive clock stays active for five more bit times after CRS goes low, to guarantee the receive timings of the controller or repeater.

2.5 100 BASE-FX

The DP83843 is fully capable of supporting 100BASE-FX applications. 100BASE-FX is similar to 100BASE-TX with the exceptions being the PMD sublayer, lack of data scrambling, and signaling medium and connectors. Chapter 26 of the IEEE 802.3u specification defines the interface to this PMD sublayer.

The DP83843 can be configured for 100BASE-FX operation either through hardware or software. Configuration through hardware is accomplished by forcing the FXEN pin (pin 21) to a logic low level prior to power-up/reset. Configuration through software is accomplished by setting bits 9:7 of the LBR register to <011>, enabling FEF1 (bit 14 of register PCSR(16h)), bypassing the scrambler (bit 12 of register LBR(17h)) and disabling Auto-Negotiation. In addition, setting the FX_EN bit of the PHYCTRL register (bit 5, address 19h) accomplishes the same function as forcing the FXEN pin (pin 21) to a logic low. In 100BASE-FX mode, the FX interface is enabled along with the Far End Fault Indication (FEFI) and Bypass Scrambler functions. **Auto-Negotiation must be disabled in order for 100BASE-FX operation to work properly.**

The diagram in Figure 11 is a block diagram representation of the FX interface and the alternative data paths for transmit, receive and signal detect.

2.0 Functional Description (Continued)

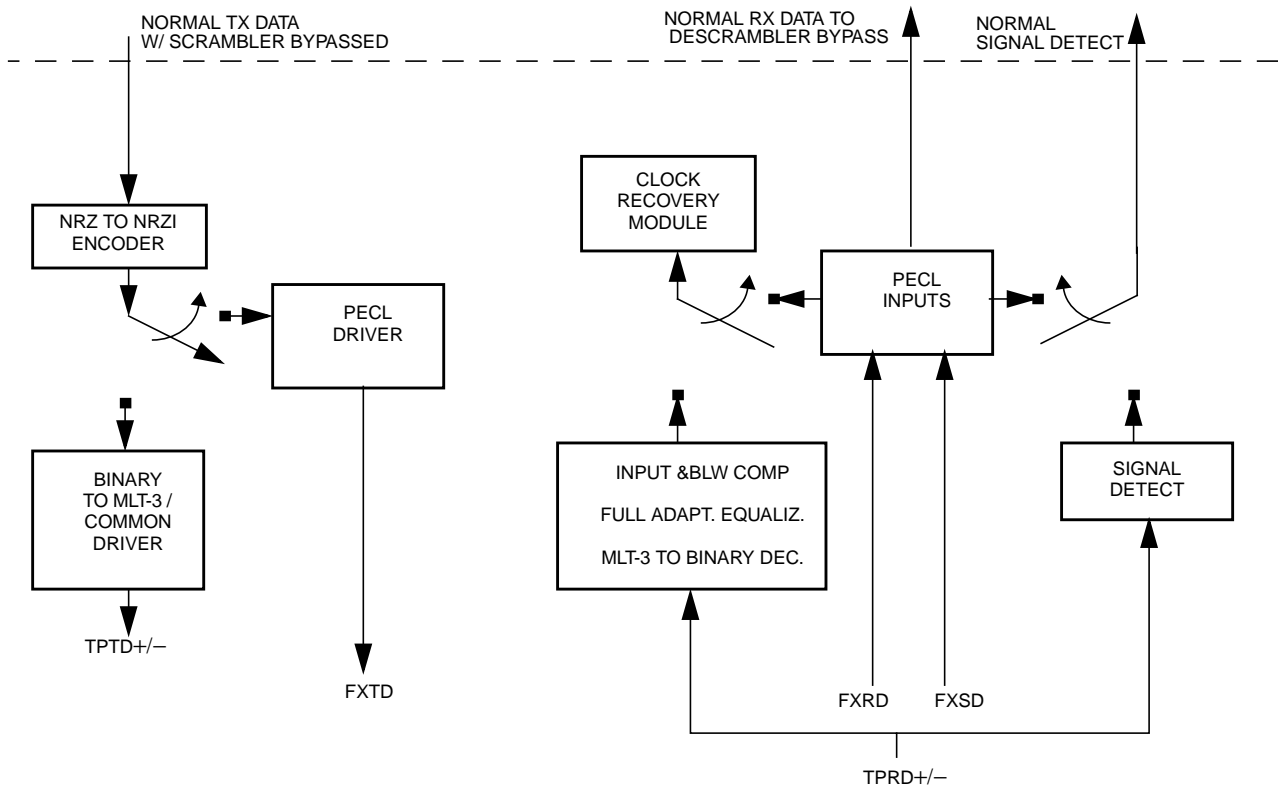

Figure 1. 100Base-FX Block Diagram

2.5.1 FX Interface

When the FX interface is enabled the internal 100BASE-TX transceiver is disabled. As defined by the 802.3u specification, `PMD_SIGNAL_indicate` (signal detect function), `PMD_UNITDATA.indicate` (receive function), and `PMD_UNIT_DATA.request` (transmit function) are supported by the `FXSD+/-`, `FXRD+/-`, and `FXTD+/-` pins respectively.

Transmit

The DP83843 transmits NRZI data on the `FXTD+/-` pins. This data is transmitted at PECL signal levels. 100BASE-FX requires no scrambling/de-scrambling, so the scrambler is bypassed in the transmit path. All other PMA and PCS functions remain unaffected.

Receive

The DP83843 receives NRZI data on the `FXRD+/-` pins. This data is accepted at PECL signal levels. 100BASE-FX requires no scrambling/de-scrambling, so the de-scrambler is bypassed in the receive path. All other PMA and PCS functions remain unaffected.

Signal Detect

The DP83843 receives signal detect information on the `FXSD+/-` pins. This data is accepted at PECL signal levels. Signal detect indicates that a signal with the proper amplitude is present at the PMD sublayer.

2.5.2 Far End Fault Indication

Auto-Negotiation provides a mechanism for transferring information from the Local Station to the Link Partner that a remote fault has occurred for 100BASE-TX. As Auto-Nego-

tiation is not currently specified for operation over fiber, the Far End Fault Indication function (FEFI) provides some degree of communication between link partners in support of 100BASE-FX operation.

A remote fault is an error in the link that one station can detect while the other cannot. An example of this is a disconnected fiber at a station's transmitter. This station will be receiving valid data and detect that the link is good via the Link Integrity Monitor, but will not be able to detect that its transmission is not propagating to the other station.

A 100BASE-FX station that detects such a remote fault (through the deassertion of signal detect) may modify its transmitted IDLE stream from all ones to a group of 84 ones followed by a single zero (i.e. 16 IDLE code groups followed by a single Data 0 code group). This is referred to as the FEFI IDLE pattern. Transmission of the FEFI IDLE pattern will continue until `FXSD+/-` is re-asserted.

If three or more FEFI IDLE patterns are detected by the DP83843, then bit 4 of the Basic Mode Status register (address 01h) is set to one until read by management. It is also set in bit 7 of the PHY Status register (address 10h).

The first FEFI IDLE pattern may contain more than 84 ones as the pattern may have started during a normal IDLE transmission which is actually quite likely. However, since FEFI is a repeating pattern, this will not cause a problem with the FEFI function. It should be noted receipt of the FEFI IDLE pattern will not cause CRS to assert.

To enable Fiber mode without FEFI, set bits 9:7 of the LBR register to `<011>`, disable FEFI (bit 14 of register `PCSR(16h)`), bypass the scrambler (bit 12 of register

2.0 Functional Description (Continued)

LBR(17h)) and disable Auto-Negotiation. Without FEFI enabled the DP83843 will not send the FEFI idle pattern.

Additionally, upon detection of Far End Fault, all receive and transmit MII activity is disabled/ignored (MII serial management is unaffected).

This function is optional for 100BASE-FX compliance and should be disabled for 100BASE-TX compliance. If Auto-Negotiation is enabled (bit 12 of the BMCR) then FEFI is automatically disabled. FEFI is automatically enabled when the DP83843 is configured for 100BASE-FX operation.

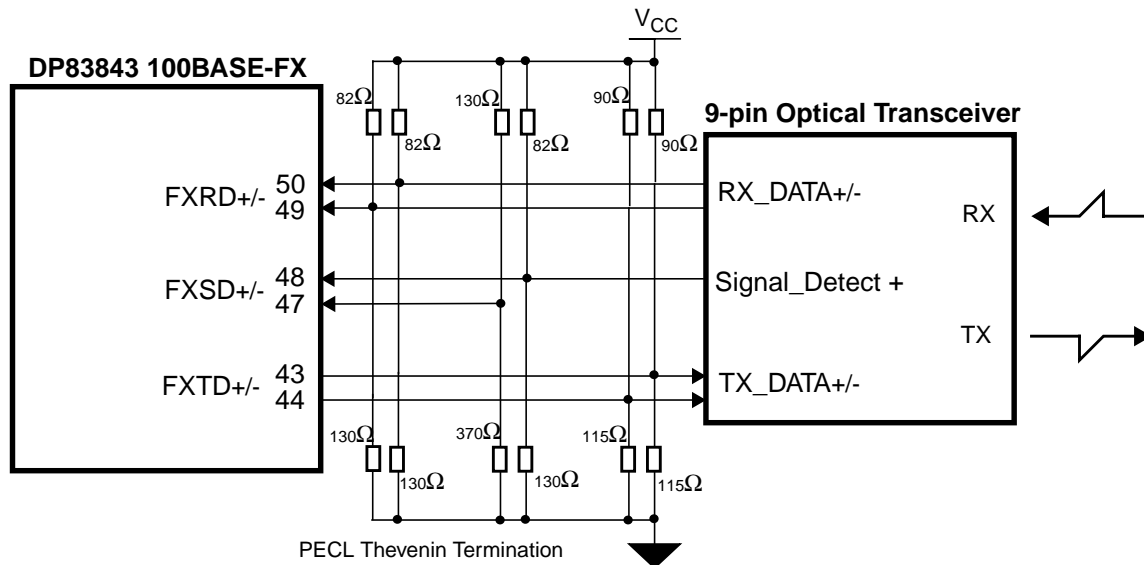

Figure 1. Typical DP83843 to Optical Transceiver Interfaces

2.5.3 Software Enable

The FX functions can also be set via software. The FX-interface is set by bit 5 of the PHYCTRL register (address 19h). The FEFL_EN function is set by bit 14 of register 16h. The bypass scrambler and de-scrambler function is set by bit 11 of the loopback and bypass register (address 17h).

2.5.4 FX Interface Considerations

The termination and signal routing for the high-speed PECL signals are critical. The following diagram shows a typical thevenin termination circuit.

Chapter 26 of the 802.3u 100BASE-X document includes references to the three most common types of 125 Mb/s optical transceiver connectors available. The DP83843 may be used with any of these three connectors.

It is important to note that the typical 9-pin low cost fiber transceiver utilizes a single-ended PECL output for Signal Detect indication. Since the DP83843 incorporates standard differential PECL inputs for Signal Detect, the FXSD-input (pin 47) can be externally biased as depicted in Figure 12 to ensure proper operation.

Optionally, the proper bias potential for FXSD- can be generated by the DP83843 internally. This is accomplished by setting bit 15 of register 16 (PCSR). This option eliminates the requirement for additional external passive components which would otherwise be required for the proper biasing of FXSD- in an application where only a single-ended SD signal is available.

2.6 AUI

The DP83843 is capable of operating in 10BASE-2 and 10BASE-5 applications. This is done by utilizing the AUI (Attachment Unit Interface) pins of the DP83843. The AUI interface is completely IEEE 802.3 compliant. See Figure 14 for an example of a typical AUI connector setup.

AUI mode is selected by bit 5 (AUI_SEL) of the 10BASE-T Control and Status register (10BTSCR). It can also be activated by the Autoswitch feature explained below. Autoswitch overrides the AUI_SEL bit. The Status of the port, either AUI or TP mode, is displayed in bit 12 (AUI_TPI) of the 10BTSCR register.

2.6.1 AUI Block Diagram

The pins at the AUI interface are AUIRD+/-, AUITD+/-, and AUCID+/- . They provide the Read, Transmit and Collision Detect functions respectively. See Figure 13 for a block diagram of the AUI interface. The AUI interface includes the

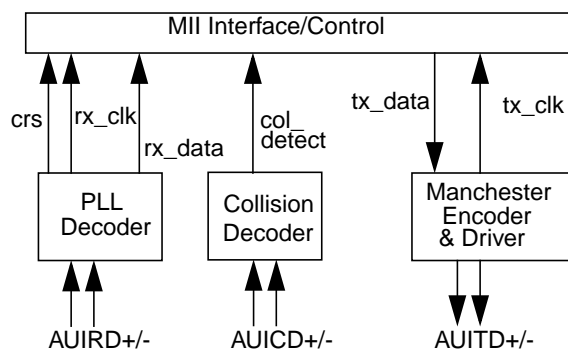

Figure 1. AUI Block Diagram

PLL Decoder, Collision Decoder and Manchester Encoder and Driver.

The PLL Decoder receives Manchester data from the transceiver, converts it to NRZ data and clock pulses and sends it to the controller.

The collision decoder indicates to the MII the presence of a valid 10 MHz collision signal to the PLL.

2.0 Functional Description (Continued)

The Manchester encoder accepts NRZ data from the MII, encodes the data to Manchester and sends it to the driver. The driver transmits the data differentially to the transceiver.

2.6.2 AUI/TP Autoswitch

The DP83843 has an autoswitching feature that allows switching between the AUI and TP operation. The AUI/TPI autoswitch feature (AUTOSW_EN) is enabled by bit 9 of the 10BASE-T Control and Status Register (10BTSCR). If AUTOSW_EN is asserted (default is de-asserted) and the DP83843 is in 10 Mb/s mode it automatically activates the TPI interface (10 Mb/s data is transmitted and received at the TPTD+/- and TPRD+/- pins respectively). If there is an absence of link pulses, the transceiver will switch to AUI mode. Similarly, when the transceiver starts detecting link pulses it will switch to TP mode. The switching from one mode to the next is only done after the current packet has been transmitted or received. If the twisted pair output is jabbering and gets into link fail state, then the switch to AUI mode is only done after the jabbering is done, including the time it takes to unjab (unjab time).

2.6.3 Ethernet Cable Configuration / THIN Output

The DP83843 offers the choice of Thick Ethernet (10BASE5) and Thin Ethernet (10BASE-2). The type of cabling used is controlled through bit 3 of the 10BTSCR register (address 18h). The DP83843 also provides a THIN output signal which can be used to disable/enable an external DC-DC converter which is required for 10BASE-2 applications to provide electrical isolation. This enables a 10BASE-2 and 10BASE-5 common interface application.

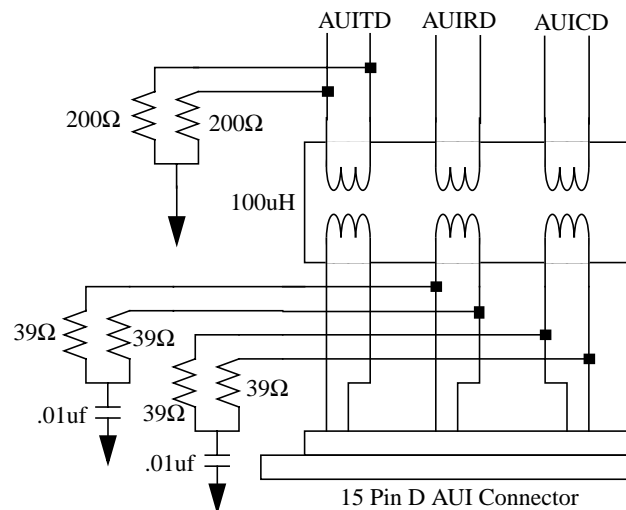

Figure 1. AUI Typical Setup

3.0 Configuration

This section includes information on the various configuration options available with the DP83843. The configuration options described herein include:

- Auto-Negotiation
- PHY Address and LEDs
- Half Duplex vs Full Duplex
- 100M Symbol mode
- 100BASE-FX mode
- 10M serial MII mode
- 10M AUI Mode
- Repeater vs. Node
- Isolate mode
- Loopback mode

3.1 Auto-Negotiation

The Auto-Negotiation function provides a mechanism for exchanging configuration information between two ends of a link segment and automatically selecting the highest performance mode of operation supported by both devices. Fast Link Pulse (FLP) Bursts provide the signaling used to communicate Auto-Negotiation abilities between two devices at each end of a link segment. For further detail regarding Auto-Negotiation, refer to clause 28 of the IEEE 802.3u specification. The DP83843 supports four different Ethernet protocols (10 Mb/s Half Duplex, 10 Mb/s Full Duplex, 100 Mb/s Half Duplex, and 100 Mb/s Full Duplex), so the inclusion of Auto-Negotiation ensures that the highest performance protocol will be selected based on the ability of the Link Partner. The Auto-Negotiation function within the DP83843 can be controlled either by internal register access or by use of the AN1 and AN0 (pins 3 & 4).

3.1.1 Auto-Negotiation Pin Control

The state of AN0 and AN1 determines whether the DP83843 is forced into a specific mode or Auto-Negotiation will advertise a specific ability (or set of abilities) as given in Table 3. Pins AN0 and AN1 are implemented as three-level control pins which are configured by connecting them to V_{CC} , GND, or by leaving them unconnected (refer to

Figure 15). These pins allow configuration options to be selected without requiring internal register access.

It should be noted that due to the internal resistor networks depicted in Figure 15, the AN0 or AN1 should be connected directly to either V_{CC} or GND, depending on the requirements. These pins should never be resistively tied to V_{CC} or GND as this will interfere with the internal pull-up and pull-down resistors resulting in improper Auto-Negotiation behavior.

The state of AN0 and AN1, upon power-up/reset, determines the state of bit 9 in the PHYSTS register (address 10h) as well as bits [8:5] of the ANAR register (address 04h).

Upon power-up/reset the DP83843 uses default register values, which enables Auto-Negotiation and advertises the full set of abilities (10 Mb/s Half Duplex, 10 Mb/s Full Duplex, 100 Mb/s Half Duplex, and 100 Mb/s Full Duplex) unless subsequent software accesses modify the mode.

The status of Auto-Negotiation as a function of hardware configuration via the AN0 and AN1 pins is reflected in bit 9 of the PHYSTS register (address 10h).

The Auto-Negotiation function selected at power-up or reset can be changed at any time by writing to the Basic Mode Control Register (BMCR) at address 00h.

3.1.2 Auto-Negotiation Register Control

When Auto-Negotiation is enabled, the DP83843 transmits the abilities programmed into the Auto-Negotiation Advertisement register (ANAR) at address 04h via FLP Bursts. Any combination of 10 Mb/s, 100 Mb/s, Half-Duplex, and Full Duplex modes may be selected. The default setting of bits [8:5] in the ANAR and bit 9 in the PHYSTS register (address 10h) are determined at power-up or hard reset by the state of the AN0 and AN1 pins.

The BMCR provides software with a mechanism to control the operation of the DP83843. However, the AN0 and AN1 pins do not affect the contents of the BMCR and cannot be used by software to obtain status of the mode selected. Bits 1 & 2 of the PHYSTS register (address 10h) are only valid if Auto-Negotiation is disabled or after Auto-Negotiation is complete.

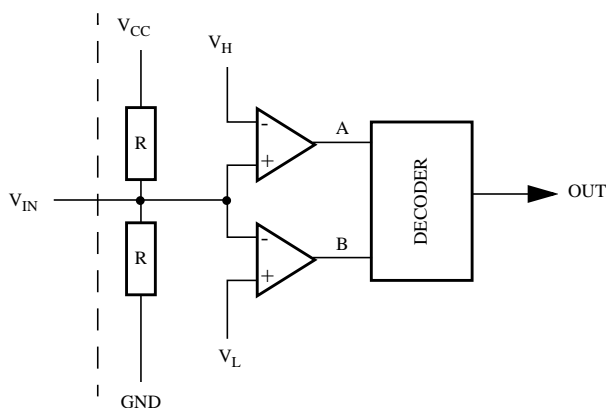

Figure 15. 3 Level Hardware Configuration Pin Control

V_{IN}	A	B	OUT
0V	L	L	L
$V_{CC}/2$	L	H	M
V_{CC}	H	H	H

The contents of the ANLPAR register are used to automatically configure to the highest performance protocol between the local and far-end ports. Software can determine which mode has been configured by Auto-Negotiation

by comparing the contents of the ANAR and ANLPAR registers and then selecting the technology whose bit is set in both the ANAR and ANLPAR of highest priority relative to the following list.

3.0 Configuration (Continued)

Table 3. Auto-Negotiation Mode Select

AN1 (Pin 3)	AN0 (Pin 4)	Action	Mode
FORCED MODES			
0	M	PHYSTS (10h) Bit 9 = 0, Bit 1 = 1, Bit 2 = 0 ANAR (04h) [8:0] = 021h	10BASE-T, Half-Duplex without Auto-Negotiation
1	M	PHYSTS (10h) Bit 9 = 0, Bit 1 = 1, Bit 2 = 1 ANAR (04h) [8:0] = 041h	10BASE-T, Full Duplex without Auto-Negotiation
M	0	PHYSTS (10h) Bit 9 = 0, Bit 1 = 0, Bit 2 = 0 ANAR (04h) [8:0] = 081h	100BASE-X, Half-Duplex without Auto-Negotiation
M	1	PHYSTS (10h) Bit 9 = 0, Bit1 = 0, Bit 2 = 1 ANAR (04h) [8:0] = 101h	100BASE-X, Full Duplex without Auto-Negotiation
ADVERTISED MODES			
M	M	PHYSTS (10h) Bit 9 = 1 ANAR (04h) [8:0] = 1E1h	All capable (i.e. Half-Duplex & Full Duplex for 10BASE-T and 100BASE-TX) advertised via Auto-Negotiation
0	0	PHYSTS (10h) Bit 9 = 1 ANAR (04h) [8:0] = 061h	10BASE-T, Half-Duplex & Full Duplex advertised via Auto-Negotiation
0	1	PHYSTS (10h) Bit 9 = 1 ANAR (04h) [8:0] = 181h	100BASE-TX, Half-Duplex & Full Duplex advertised via Auto-Negotiation
1	0	PHYSTS (10h) Bit 9 = 1 ANAR (04h) [8:0] = 0A1h	10BASE-T & 100BASE-TX, Half-Duplex advertised via Auto-Negotiation
1	1	PHYSTS (10h) Bit 9 = 1 ANAR (04h) [8:0] = 021h	10 BASE-T, Half-Duplex advertised via Auto-Negotiation.

Note: "M" indicates logic mid level ($V_{CC}/2$), "1" indicates logic high level, "0" indicates logic low level.

Auto-Negotiation Priority Resolution:

- (1) 100BASE-TX Full Duplex (Highest Priority)
- (2) 100BASE-TX Half Duplex
- (3) 10BASE-T Full Duplex
- (4) 10BASE-T Half Duplex (Lowest Priority)

The Basic Mode Control Register (BMCR) at address 00h provides control of enabling, disabling, and restarting of the Auto-Negotiation function. When Auto-Negotiation is disabled the Speed Selection bit in the BMCR (bit 13, register address 00h) controls switching between 10 Mb/s or 100 Mb/s operation, while the Duplex Mode bit (bit 8, register address 00h) controls switching between full duplex operation and half duplex operation. The Speed Selection and Duplex Mode bits have no effect on the mode of operation when the Auto-Negotiation Enable bit (bit 12, register address 00h) is set.

The Basic Mode Status Register (BMSR) at address 01h indicates the set of available abilities for technology types (bits 15 to 11, register address 01h), Auto-Negotiation ability (bit 3, register address 01h), and Extended Register Capability (bit 0, register address 01h). These bits are permanently set to indicate the full functionality of the DP83843 (only the 100BASE-T4 bit is not set since the DP83843 does not support that function, while it does support all the other functions).

The BMSR also provides status on:

- Whether Auto-Negotiation is complete (bit 5, register address 01h)

- Whether the Link Partner is advertising that a remote fault has occurred (bit 4, register address 01h)
- Whether a valid link has been established (bit 2, register address 01h)
- Support for Management Frame Preamble suppression (bit 6, register address 01h)

The Auto-Negotiation Advertisement Register (ANAR) at address 04h indicates the Auto-Negotiation abilities to be advertised by the DP83843. All available abilities are transmitted by default, but any ability can be suppressed by writing to the ANAR. Updating the ANAR to suppress an ability is one way for a management agent to change (force) the technology that is used.

The Auto-Negotiation Link Partner Ability Register (ANLPAR) at address 05h is used to receive the base link code word as well as all next page code words during the negotiation. Furthermore, the ANLPAR will be updated to either 0081h or 0021h for parallel detection to either 100 Mb/s or 10 Mb/s respectively.

If Next Page is NOT being used, then the ANLPAR will store the base link code word (link partner's abilities) and retain this information from the time the page is received, as indicated by a 1 in bit 1 of the Auto-Negotiation Expansion Register (ANER, register address 06h), through the end of the negotiation and beyond.

When using the next page operation, the DP83843 cannot wait for Auto-Negotiation to complete in order to read the ANLPAR because the register is used to store both the

3.0 Configuration (Continued)

base and next pages. Software must be available to perform several functions. The ANER (register 6) must have a page received (bit 1), once the DP83843 receives the first page, software must store it in memory if it wants to keep the information. Auto-Negotiation keeps a copy of the base page information but it is no longer accessible by software. After reading the base page information, software needs to write to ANNPTR (register 7) to load the next page information to be sent. Continue to poll the page received bit in the ANER and when active read the ANLPAR. The contents of the ANLPAR will tell if the partner has further pages to be sent. As long as the partner has more pages to send, software must write to the next page transmit register and load another page.

The Auto-Negotiation Expansion Register (ANER) at address 06h indicates additional Auto-Negotiation status. The ANER provides status on:

- Whether a Parallel Detect Fault has occurred (bit 4, register address 06h)
- Whether the Link Partner supports the Next Page function (bit 3, register address 06h)
- Whether the DP83843 supports the Next Page function (bit 2, register address 06h). The DP83843 does support the Next Page function.
- Whether the current page being exchanged by Auto-Negotiation has been received (bit1, register address 06h)
- Whether the Link Partner supports Auto-Negotiation (bit 0, register address 06h)

The Auto-Negotiation Next Page Transmit Register (ANNPTR) at address 07h contains the next page code word to be sent. See Table 13 for a bit description of this register.

3.1.3 Auto-Negotiation Parallel Detection

The DP83843 supports the Parallel Detection function as defined in the IEEE 802.3u specification. Parallel Detection requires both the 10 Mb/s and 100 Mb/s receivers to monitor the receive signal and report link status to the Auto-Negotiation function. Auto-Negotiation uses this information to configure the correct technology in the event that the Link Partner does not support Auto-Negotiation yet is transmitting link signals that the 100BASE-X or 10BASE-T PMAs recognize as valid link signals.

The Auto-Negotiation function will only accept a valid link signal for the purpose of Parallel Detection from PMAs which have a corresponding bit set in the Auto-Negotiation Advertisement register, (ANAR register bits 5 and 7, address 04h.) This allows the DP83843 to be configured for 100 Mb/s only, 10 Mb/s only, or 10 Mb/s & 100 Mb/s CSMA/CD operation depending on the advertised abilities. The state of these bits may be modified via the AN0 and AN1 pins or by writing to the ANAR. For example, if bit 5 is zero, and bit 7 is one in the ANAR (i.e. 100 Mb/s CSMA/CD only), and the Link Partner is 10BASE-T without Auto-Negotiation, then Auto-Negotiation will not complete since the advertised abilities and the detected abilities have no common mode. This operation allows the DP83843 to be used in single mode (i.e. repeater) applications as well as dual mode applications (i.e. 10/100 nodes or switches).

If the DP83843 completes Auto-Negotiation as a result of Parallel Detection, without Next Page operation, bits 5 and 7 within the ANLPAR register (register address 05h) will be set to reflect the mode of operation present in the Link Part-

ner. Note that bits 4:0 of the ANLPAR will also be set to 00001 based on a successful parallel detection to indicate a valid 802.3 selector field. Software may determine that negotiation completed via Parallel Detection by reading a zero in the Link Partner Auto-Negotiation Able bit (bit 0, register address 06h) once the Auto-Negotiation Complete bit (bit 5, register address 01h) is set. If configured for parallel detect mode and any condition other than a single good link occurs then the parallel detect fault bit will set (bit 4, register 06h).

3.1.4 Auto-Negotiation Restart

Once Auto-Negotiation has completed, it may be restarted at any time by setting bit 9 of the BMCR to one. If the mode configured by a successful Auto-Negotiation loses a valid link, then the Auto-Negotiation process will resume and attempt to determine the configuration for the link. This function ensures that a valid configuration is maintained if the cable becomes disconnected.

A renegotiation request from any entity, such as a management agent, will cause the DP83843 to halt any transmit data and link pulse activity until the break_link_timer expires (~1500ms). Consequently, the Link Partner will go into link fail and normal Auto-Negotiation resumes. The DP83843 will resume Auto-Negotiation after the break_link_timer has expired by issuing FLP (Fast Link Pulse) bursts.

3.1.5 Enabling Auto-Negotiation via Software

It is important to note that if the DP83843 has been initialized upon power-up as a non-auto-negotiating device (forced technology), and it is then required that Auto-Negotiation or re-Auto-Negotiation be initiated via software, bit 12 of the Basic Mode Control Register (address 00h) must first be cleared and then set for any Auto-Negotiation function to take effect.

3.1.6 Auto-Negotiation Complete Time

Parallel detection and Auto-Negotiation take approximately 2-3 seconds to complete. In addition, Auto-Negotiation with next page should take approximately 2-3 seconds to complete, depending on the number of next pages sent.

Refer to chapter 28 of the IEEE 802.3u standard for a full description of the individual timers related to Auto-Negotiation.

Auto-Negotiation Next Page Support

The DP83843 supports the optional Auto-Negotiation Next Page protocol. The ANNPTR register (address 07h) allows for the configuration and transmission of Next Page. Refer to clause 28 of the IEEE 802.3u standard for detailed information regarding the Auto-Negotiation Next Page function.

3.2 PHY Address and LEDs

The DP83843 maps the 5 PHY address input pins onto the 5 LED output pins as:

```
LED_COL <=> PHYAD[0]
LED_TX <=> PHYAD[1]
LED_RX <=> PHYAD[2]
LED_LINK <=> PHYAD[3]
LED_FDPOL <=> PHYAD[4]
```

The DP83843 can be set to respond to any of 32 possible PHY addresses. Each DP83843 connected to a common serial MII must have a unique address. It should be noted

3.0 Configuration (Continued)

that while an address selection of all zeros <00000> will result in PHY Isolate mode, this will not effect serial management access.

The state of each of the PHYAD inputs are latched into the PHYCTRL register bits [4:0] (address 19h) at system power-up/reset depending on whether a pull-up or pull-down resistor has been installed for each pin. For further detail relating to the latch-in timing requirements of the PHY Address pins, as well as the other hardware configuration pins, refer to the Reset summary in Section 5.

Since the PHYAD strap options share the LED output pins, the external components required for strapping and LED usage must be considered in order to avoid contention. Additionally, the sensing and auto polarity feature of the LED must be taken into account.

Specifically, these LED outputs can be used to drive LEDs directly, or can be used to provide status information to a network management device. The active state of each LED output driver is dependent on the logic level sampled by the corresponding PHYAD input upon power-up / reset. For example, if a given PHYAD input is resistively pulled low (nominal 10 kΩ resistor recommended) then the corresponding LED output will be configured as an active high driver. Conversely, if a given PHYAD input is resistively pulled high, then the corresponding LED output will be configured as an active low driver. Refer to Figure 16 for an example of LED & PHYAD connection to external components where, in this example, the PHYAD strapping results in address 00011 or hex 03h or decimal 3.

The adaptive nature of the LED outputs helps to simplify potential implementation issues of these dual purpose pins.

Refer to the PHYCTRL register (address 19h) bits [8:6] for further information regarding LED operations and configuration.

3.3 Half Duplex vs. Full Duplex

The DP83843 supports both half and full duplex operation at both 10 Mb/s and 100 Mb/s speeds.

Half-duplex is the standard, traditional mode of operation which relies on the CSMA/CD protocol to handle collisions and network access. In Half-Duplex mode, CRS responds to both transmit and receive activity in order to maintain compliant to the IEEE 802.3 specification.

Since the DP83843 is architected to support simultaneous transmit and receive activity it is capable of supporting full-duplex switched applications with an aggregate throughput of up to 200 Mb/s when operating in 100BASE-X mode. Because the CSMA/CD protocol does not apply to full-duplex operation, the DP83843 simply disables its own internal collision sensing and reporting functions and modifies the behavior of Carrier Sense (CRS) such that it indicates only receive activity to allow the full-duplex capable MAC to operate properly.

All modes of operation (100BASE-TX, 100BASE-FX, 10BASE-T (both nibble and serial)) can run full-duplex although it should be noted that full-duplex operation does not apply to typical repeater implementations or AUI applications. Additionally, other than CRS and Collision reporting, all remaining MII signaling remains the same regardless of the selected duplex mode.

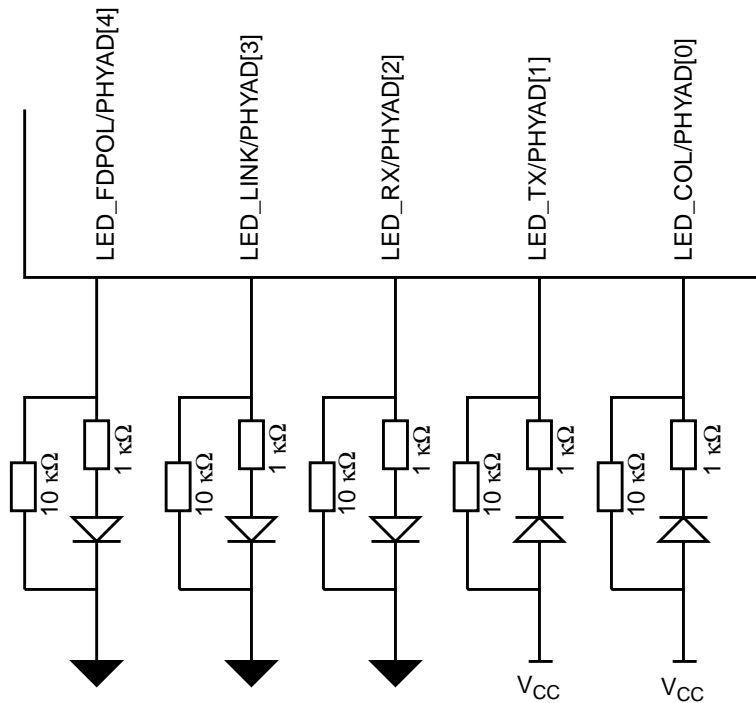

Figure 16. PHYAD Strapping and LED Loading Example

3.0 Configuration (Continued)

It is important to understand that while full Auto-Negotiation with the use of Fast Link Pulse code words can interpret and configure to support full-duplex, parallel detection can not recognize the difference between full and half-duplex from a fixed 10 Mb/s or 100 Mb/s link partner over twisted pair. Therefore, as specified in 802.3u, if a far-end link partner is transmitting forced full duplex 100BASE-TX for example, the parallel detection state machine in the receiving station would be unable to detect the full duplex capability of the far-end link partner and would negotiate to a half duplex 100BASE-TX configuration (same scenario for 10 Mb/s).

3.4 100 Mb/s Symbol Mode

In Symbol mode, all of the conditioning blocks in the transmit and receive sections of the 100BASE-X section are bypassed. The 100BASE-X serial data received at the RD+/- inputs of the DP83843 are recovered by the integrated PMD receiver, shifted into 5-bit parallel words and presented to the MII receive outputs RXD[3:0] and RX_ER/RXD[4]. All data, including Idles, passes through the DP83843 unaltered other than for serial/parallel conversions.

Similarly, the TX_ER input pin is configured as the new MSB (TXD[4]) to support the unaligned 5 bit transmit data.

All data, including Idles, passes through the DP83843 unaltered other than for serial/parallel conversions.

While in Symbol mode RX_DV and COL are held low and TX_ER is used as the fifth bit and no longer functions as TX_ER. Additionally, the CRS output reports the state of signal detect as generated internally for 100BASE-TX and externally for 100BASE-FX.

Symbol mode can be used for those applications where the system design requires only the integrated PMD, clock recovery, and clock generation functions of the DP83843. This is accomplished either by configuring the CRS/SYMBOL pin (pin 22) of the DP83843 to a logic low level prior to power-up/reset or by setting bits 10 and 11 (BP_TX and BP_RX respectively) of the LBR register (address 17h) through the serial MII port. Symbol mode only applies to 100BASE-X operation.

3.5 100BASE-FX Mode

The DP83843 will allow 100BASE-FX functionality by bypassing the scrambler and descrambler and routing the PECL serial transmit and receive data through the separate FXTD/AUITD outputs and FXRD/AUIRD inputs respectively. Additionally, the signal detect indication from the optical transceiver is handled by the FXSD inputs. Placing the DP83843 in 100BASE-FX mode disables the TPTD and TPRD transmit and receive pin pairs.

Configuring the DP83843 for 100BASE-FX mode can be accomplished either through hardware configuration or via software.

The hardware configuration is set simply by tying the COL/FXEN pin (21) to a logic low level prior to power-on/reset. The software setting is accomplished by setting the BP_SCR bit (bit 12) of the LBR register (address 17h) via MII serial management.

The DP83843 can support either half-duplex or full-duplex operation while in 100BASE-FX mode. Additionally, all MII signaling remains identical to that of 100BASE-TX operation.

Please refer to Section 2.2 for more information regarding 100BASE-FX operation.

3.6 10 Mb/s Serial Mode

The DP83843 allows for serial MII operation. In this mode, the transmit and receive MII data transactions occur serially at a 10 MHz clock rate on the least significant bits (RXD[0] and TXD[0]) of the MII data pins. This mode is intended for use with a MAC based on a 10 Mb/s serial interface.

While the MII control signals (CRS, RX_DV, TX_DV, and TX_EN) as well as RX_EN and Collision are still used during 10 Mb/s Serial mode, some of the timing parameters are different. Refer to Section 8 for AC timing details.

Both 10BASE-T and AUI can be configured for Serial mode. Serial mode is not supported for 100 Mb/s operation.

Serial mode can be selected via hardware by forcing the SERIAL10 pin (pin 69) to a logic low level prior to power-up/reset. The state of the SERIAL10 pin is latched into bits 11 and 12 of the 10BTSCR register (address 18h) as a result of power-up/reset. These bits can be written through software to control serial mode operation.

While in 10 Mb/s serial mode, RXD[3:1] will be placed in TRI-STATE mode and RX_DV asserts coincident with CRS.

3.7 10 Mb/s AUI Mode

Placing the DP83843 in AUI mode enables the FXTD/AUITD, FXRD/AUIRD, and FXSD/CD pin pairs to allow for any AUI compliant external transceivers to be connected to the AUI interface. Placing the DP83843 in 10 Mb/s AUI mode disables the TPTD and TPRD transmit and receive pin pairs.

The DP83843 also incorporates a THIN output control pin for use with traditional AUI based CTI transceivers. This output follows the state of bit 3 in the 10BTSCR register accessible through the serial MII.

The AUI/TP autoswitching allows transceiver autoswitching between the AUI and TP outputs. At power up, the autoswitch function is deselected in the 10BTSCR register (bit 9 = 0) and the current mode, AUI or TP, is reported by the bit 13 of the 10BTSCR register (low for TPI and high for AUI).

When the auto-switch function is enabled (bit 9 = 1), it allows the transceiver to automatically switch between TPI and AUI I/O's. If there is an absence of link pulses, the transceiver switches to AUI mode. Similarly, when the transceiver starts detecting link pulses, it switches to TP mode. Switching from one mode to the other is done only after the current packet has been transmitted or received. If the twisted pair output is jabbering and it gets into link fail state, then the switch to AUI mode is done only after the jabbering has stopped, including the time it takes to unjab (unjab time). Also, if TPI mode is selected, transmit packet data are driven only by the TPI outputs and the AUI transmit outputs remain idle. Similar behavior applies when AUI mode is selected. The only difference in AUI mode is that the TP drivers continue to send link pulses; however, no packet data is transmitted. The TPI receive circuitry and the Link Integrity state machine are always active to enable this algorithm to function as described above.

3.0 Configuration (Continued)

3.8 Repeater vs. Node

The DP83843 Carrier Sense (CRS) operation depends on the value of the Repeater bit in the PHYCTRL register (bit 9, address 19h). When set high, the CRS output (pin 22) is asserted for receive activity only. When set low, the CRS output is asserted for either receive or transmit activity. The default value for this bit is set by the THIN/REPEATER pin (pin 63) at power-up/reset.

There is an internal pullup resistor for this pin which is active during the power-up/reset period. If this pin is left floating externally, then the device will configure to Repeater mode as a result of power-up/reset. This pin must be externally pulled low (typically 10 k Ω) in order to configure the DP83843 for node operation.

When the repeater mode of operation is selected during 100 Mb/s operation, there are two parameters that are directly effected.

First, CRS will only respond to receive activity.

Second, in compliance with the 802.3 standard, the Carrier Integrity Monitor (CIM) function is automatically enabled for detection and reporting of bad start of stream delimiters (whereas in node mode the CIM is disabled).

The Dp83843 does not support 10Mb/s repeater applications.

3.9 Isolate Mode

An IEEE 802.3u compliant PHY connected to the mechanical MII interface is required to have a default value of one in bit 10 of the Basic Mode Control Register (BMCR, address 00h.) The DP83843 will set this bit to one if the PHY Address is set to 00000 upon power-up/hardware reset. Otherwise, the DP83843 will set this bit to zero upon power-up/hardware reset. Refer to Section 2.4.2 for information relating to the requirements for selecting a given PHYAD.

With bit 10 in the BMCR set to one the DP83843 does not respond to packet data present at TXD[3:0], TX_EN, and TX_ER inputs and presents a high impedance on the TX_CLK, RX_CLK, RX_DV, RX_ER, RXD[3:0], COL, and CRS outputs. The DP83843 will continue to respond to all management transactions.

While in Isolate mode, the TD+/- outputs will not transmit packet data but will continue to source 100BASE-TX scrambled idles or 10BASE-T normal link pulses.

3.10 Loopback

The DP83843 includes a Loopback Test mode for easy board diagnostics. The Loopback mode is selected through bit 14 ('Loopback') of the Basic Mode Control Register (BMCR). The status of this mode may be checked in bit 3 of the PHY Status Register. Writing 1 to this bit enables MII transmit data to be routed to the MII receive outputs. In Loopback mode the data will not be transmitted on to the media. This occurs for either 10 Mb/s or 100 Mb/s data.

Normal 10BASE-T, 10BASE-2, or 10BASE-5 operation, in order to be standard compliant, also loops back the MII transmit data to the MII receive data. However the data is also allowed to be transmitted out the AUI or TP ports (depending on the mode).

In 100 Mb/s Loopback mode the data is routed through the PCS and PMA layers into the PMD sublayer before it is looped back. Therefore, in addition to serving as a board

diagnostic, this mode serves as quick functional verification of the device.

In addition to Loopback mode, there are many other test modes that serve similar loopback functions. These modes are mutually exclusive with Loopback mode, enabling Loopback mode disables the following test modes:

- CP_Loop (bits 9:7) of the Loopback and Bypass Register (LBR). These bits control the 100 Mb/s loopback functions in more depth. A write of either a 0 or 1 to 'Loopback' causes these bits to be set to <000> which is normal operation. At reset if FXEN is true then this will default to, <011> which is Normal Fiber operation, otherwise it will default to <000>. The other modes are explained in the LBR definition table.
- Dig_Loop (bit 6) of the LBR. Digital loopback is used to place the digital portions of the DP83843 into loopback prior to the signals entering the analog sections. A write of either a 0 or 1 to 'Loopback' causes this bits to be set to 0 which is digital loopback disabled.

Bit 5 and Bit 4 of the LBR are automatically enabled in Loopback mode. They are TWISTER (100 Mb/s) loopback and TREX (10 Mb/s) loopback modes respectively.

4.0 Clock Architecture

The DP83843 incorporates a sophisticated Clock Generation Module (CGM) design which allows full operation supporting all modes with a single 25 MHz (± 50 ppm) CMOS level reference clock. As depicted in Figure 17, the single 25 MHz reference serves both the 100 Mb/s and 10 Mb/s mode clocking requirements.

The DP83843 also incorporates Clock Recovery circuitry (CRM) which extracts the 125 MHz clock from the 125 Mb/s receive datastream present during 100BASE-TX and 100BASE-FX applications (Figure 17).

The 10 Mb/s receive clock requirements are handled by a PLL which is tuned to extract a clock from either 10BASE-T or AU1 receive Manchester encoded data streams (Figure 17).

4.1 Clock Generation Module (CGM)

For 100 Mb/s operation, the external 25 MHz reference is routed to a 250 MHz voltage controlled oscillator. The high frequency output from the oscillator is divided by two and

serves to clock out the 125Mb/s serial bit stream for 100BASE-TX and 100BASE-FX applications. The 125 MHz clock is also routed to a counter where it is divided by 5 to produce the 25 MHz TX_CLK signal for the transmit MII. Additionally, a set of phase related 250 MHz clock signals are routed to the Clock Recovery Module (CRM) which act as a frequency reference to ensure proper operation.

For 10 Mb/s operation, the external 25 MHz reference is routed to a 100 MHz voltage controlled oscillator. The high frequency output from the oscillator is divided by five and serves to clock out the 10BASE-T or AU1 serial bit stream for 10 Mb/s applications. The 100 MHz clock is also routed to a counter where it is divided by either eight or two to produce the 2.5 MHz or 10 MHz TX_CLK signal for the transmit MII. Additionally, a set of phase related 100 MHz clock signals are routed to the Clock Recovery Module (CRM) which act as a frequency reference to ensure proper operation.

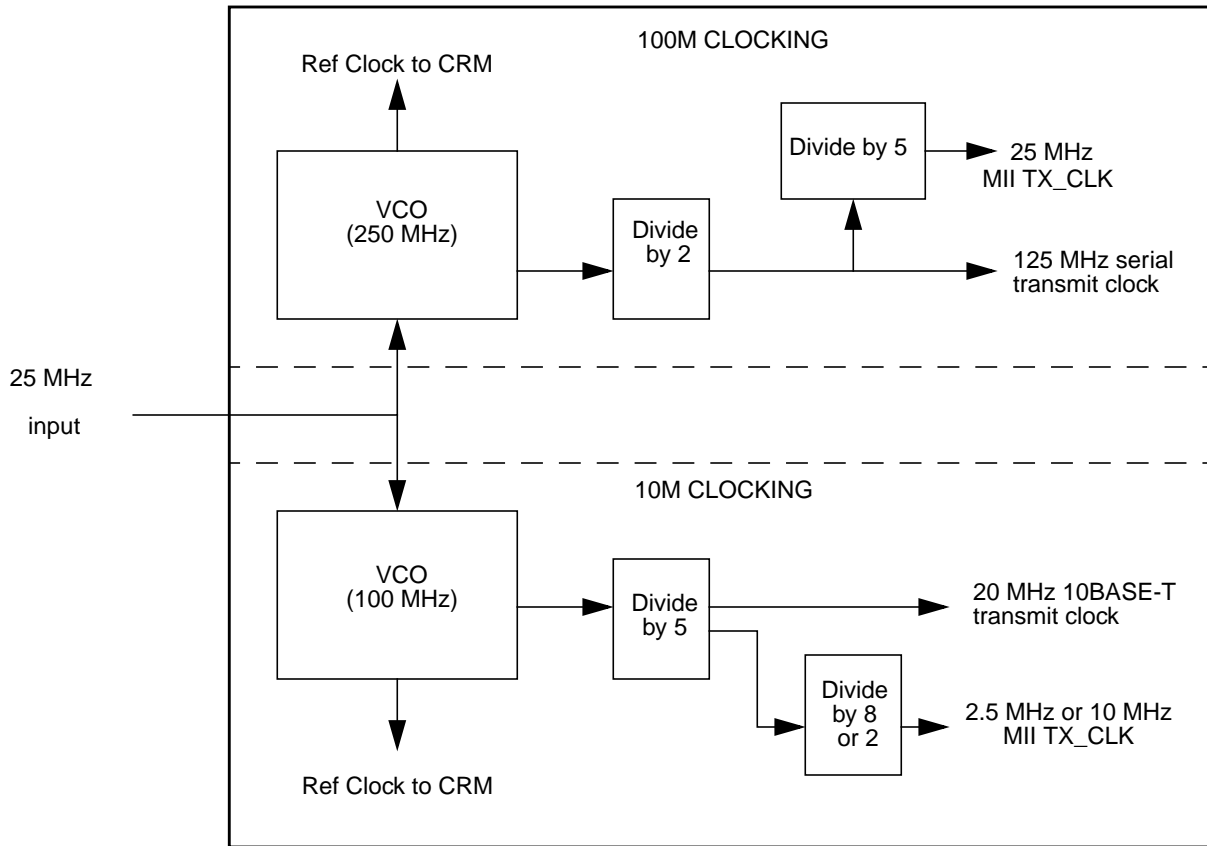

Figure 17. Clock Generation Module BLOCK DIAGRAM

4.0 Clock Architecture (Continued)

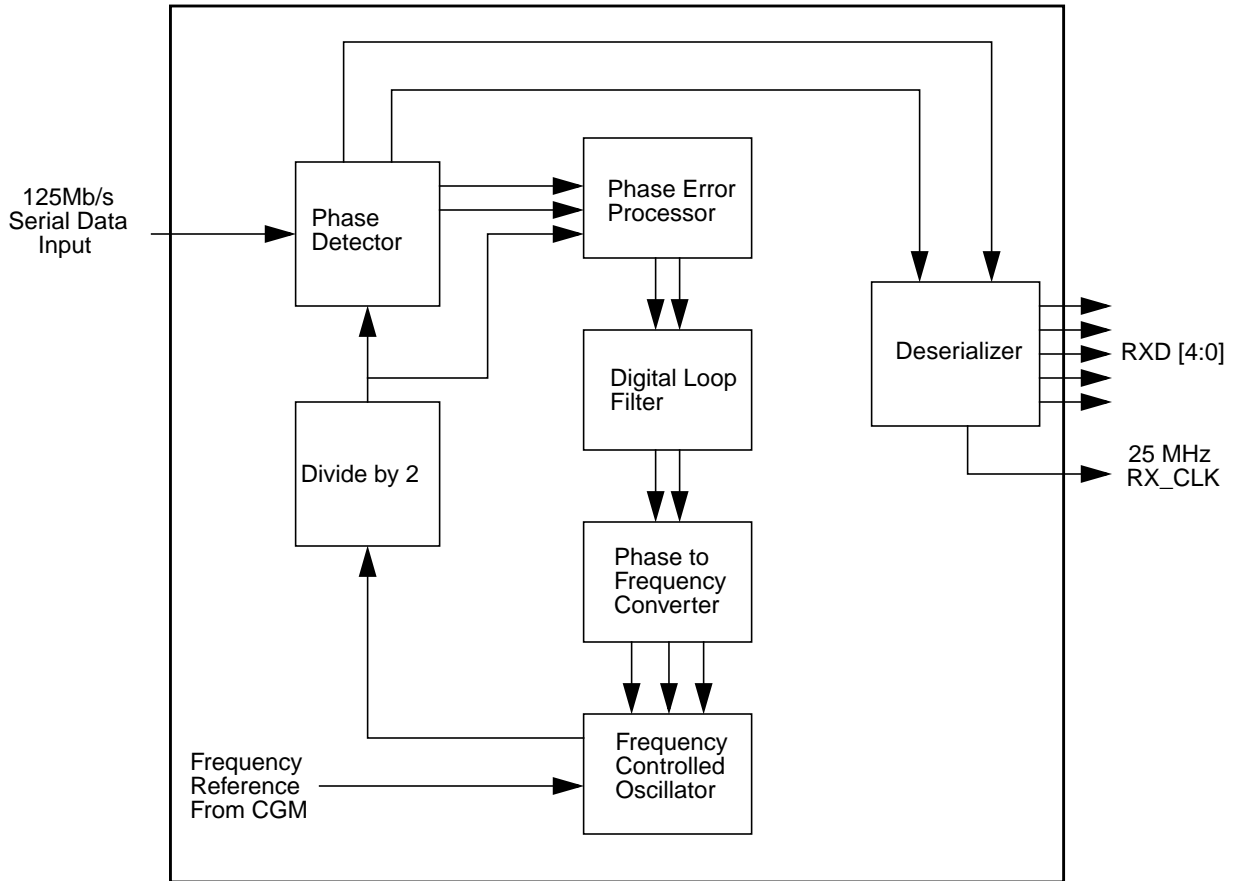

Figure 18. 100BASE-X Clock Recovery Module block diagram

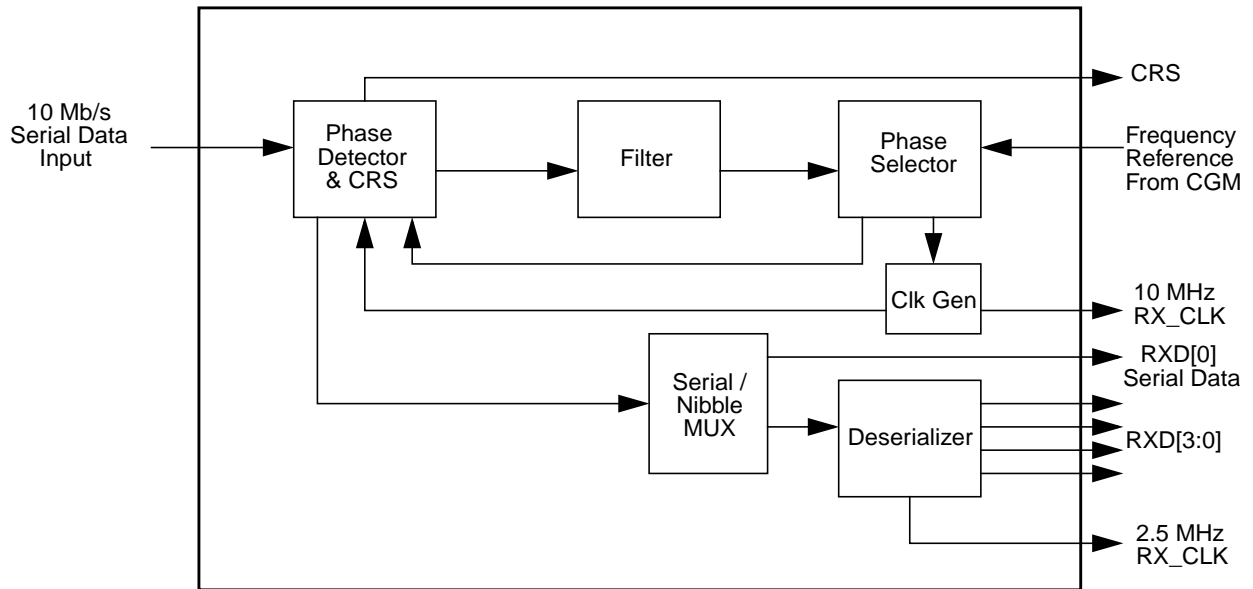

Figure 19. 10M Manchester Clock Recovery Module block diagram

4.0 Clock Architecture (Continued)

4.2 100BASE-X Clock Recovery Module

The diagram in Figure 18 illustrates a high level block architecture of the 100BASE-X Clock Recovery circuit. The 125Mb/s serial binary receive data stream that has been recovered by the integrated TP-PMD receiver is routed to the input of the phase detector. A loop consisting of the phase detector, phase error processor, digital loop filter, phase to frequency converter, and the frequency controlled oscillator then works to synthesize a 125 MHz clock based on the receive data stream. This clock is used to latch the serial data into the deserializer where the data is then converted to 5-bit code groups for processing by descrambler, code-group alignment, and code-group decoder functional blocks.

4.3 10 Mb/s Clock Recovery Module

The diagram in Figure 19 illustrates a high level block architecture of the 10 Mb/s Clock Recovery circuit. The 10 Mb/s serial Manchester receive data stream, from either the

10BASE-T or AUI inputs, is routed to the input of the phase detector. A loop consisting of the phase detector, digital loop filter, phase selector, and the frequency generator then works to synthesize a 20 MHz clock based on the receive data stream. This clock is used to latch the serial data into the deserializer where the data is then optionally converted to 4-bit code groups for presentation to the MII as nibble wide data clocked out at 2.5 MHz. Optionally, the deserializer can be bypassed and the 10 Mb/s data is clocked out serially at 10 MHz.

As a function of the Phase Detector, upon recognizing an incoming 10 Mb/s datstream, Carrier Sense (CRS) is generated for use by the MAC.

4.4 Reference Clock Connection Options

The two basic options for connecting the DP83843 to an external reference clock consist of the use of either an oscillator or a crystal. Figure 20 and 21 illustrate the recommended connection for the two typical options.

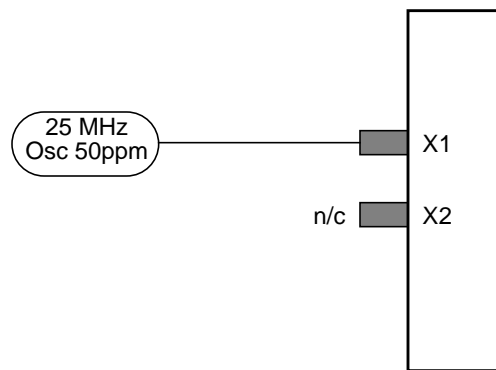

Figure 20. Oscillator Reference Clock Connection Diagram

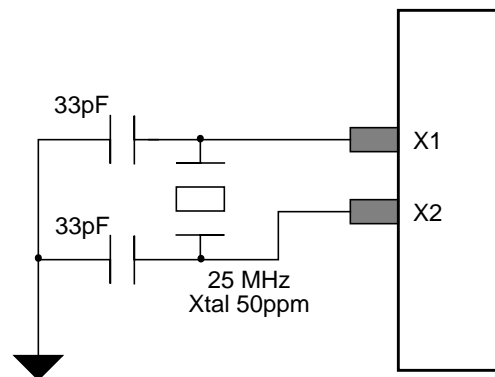

Figure 21. Xtal Reference Clock Connection Diagram

5.0 Reset Operation

The DP83843 can be reset either by hardware or software. A hardware reset may be accomplished either by asserting the RESET pin during normal operation, or upon powering up the device. A software reset is accomplished by setting the reset bit in the Basic Mode Control Register.

While either the hardware or software reset can be implemented at any time after device initialization, **providing a hardware reset, as described in Section 6.2 must be implemented upon device power-up/initialization. Omitting the hardware reset operation during the device power-up/initialization sequence can result in improper device operation.**

Depending on the crystal starting up time, it is recommended to wait 20 ms after the supply has reached its proper value before initiating a hardware reset.

5.1 Power-up / Reset

When V_{CC} is first applied to the DP83843 it takes some amount of time for power to actually reach the nominal 5V potential. This initial power-up time can be referred to as a V_{CC} ramp when V_{CC} is “ramping” from 0V to 5V. When the initial V_{CC} ramp reaches approximately 4V, the DP83843 begins an internal reset operation which must be allowed sufficient time, relative to the assertion and deassertion of the RESET pin, to reset the device. There are two methods for guaranteeing successful reset upon device power-up.

The first method accounts for those designs that utilize a special power up circuit which, through hardware, will assert the RESET pin upon power-up. In this case, the deassertion (falling edge) of the RESET pin must not occur until at least 500 μ s after the time at which the V_{CC} ramp initially reached the 4V point.

The second method accounts for those applications which produce a reset pulse sometime after the initial power-up of the device. In this case, it is recommended that a positive pulse, with a duration of at least 1 μ s, be applied to the RESET pin no sooner than 500 μ s after the point in time where the initial V_{CC} ramp reached 4V.

In both methods described above, it is important to note that the logic levels present at each of the hardware configuration pins of the DP83843 (see list below) are also latched into the device as a function of the reset operation (either hardware or software). These hardware configuration values are guaranteed to be latched into the DP83843 2 μ s after the deassertion of the RESET pin.

The hardware configuration values latched into the DP83843 during the reset operation are dependent on the logic levels present at the device pins shown in Table 4 upon power-up.

During the power-up/ reset operation the $\overline{LED1}$ through $\overline{LED5}$ pins are undefined, the SPEED10 will be asserted. The 25 MHz clock reference must be applied for reset to take effect.

5.2 Hardware Reset

A hardware reset is accomplished by applying a positive pulse (TTL level), with a duration of at least 1 μ s, to the RESET pin of the DP83843 during normal operation. This will reset the device such that all registers will be reset to default values and the hardware configuration values will be re-latched into the device (similar to the power-up/reset operation).

Table 4. Latched pins at Reset

Pin #	Primary Function	Latched in at Reset
21	COL	FXEN
22	CRS	SYMBOL
38	LED_FDPOL	PHYAD4
39	LED_LINK	PHYAD3
40	LED_RX	PHYAD2
41	LED_TX	PHYAD1
42	LED_COL	PHYAD0
63	THIN	REPEATER
69	SERIAL10	SERIAL10

5.3 Software Reset

A software reset is accomplished by setting the reset bit (bit 15) of the Basic Mode Control register (address 00h). This bit is self clearing and, when set, will return a value of “1” until the software reset operation has completed. The period from the point in time when the reset bit is set to the point in time when software reset has concluded is approximately 5 μ s.

The software reset will reset the device such that all registers will be reset to default values and the hardware configuration values will be re-latched into the device (similar to the power-up/reset operation). Driver code should wait 500 μ s following a software reset before allowing further serial MII operations with the DP83843.

6.0 DP83843 Application

6.1 Typical Node Application

Figure 22 illustrates a typical implementation of a 10/100 Mb/s node application. This is given only to indicate the major circuit elements of such a design. It is not intended to be a full circuit diagram. For detailed system level application information please contact your local National sales representative.

6.2 Power And Ground Filtering

Sufficient filtering between the DP83843 power and ground pins placed as near to these pins as possible is recommended. Figure 23 suggests one option for device noise filtering including special consideration for the sensitive analog power pins.

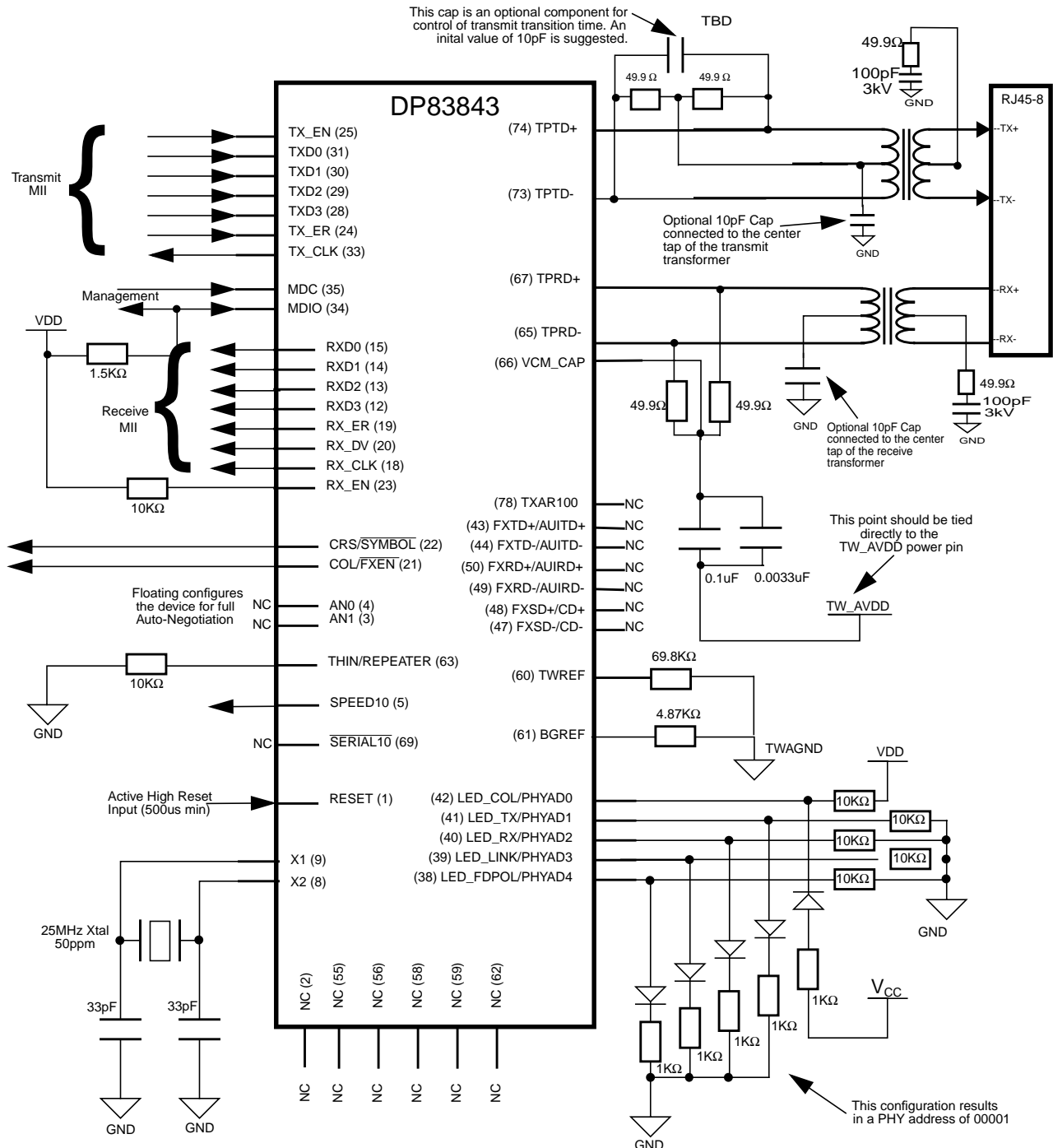

Figure 22. Typical Implementation of 10/100 Mb/s Node Application

6.3 Power Plane Considerations

The recommendations for power plane considerations pro-

vided herein represent a more simplified approach when compared to earlier recommendations. By reducing the number of instances of plane partitioning within a given

6.0 DP83843 Application (Continued)

system design, empirical data has shown a resultant improvement (reduction) in radiated emissions testing. Additionally, by eliminating power plane partitioning within the system V_{CC} and system ground domains, specific impedance controlled signal routing can remain uninterrupted.

By placing chassis ground on the top and bottom layers, additional EMI shielding is created around the 125Mb/s signal traces that must be routed between the magnetics and the RJ45-8 media connector. The example in Figure 24 assumes the use of Micro-Strip impedance control techniques for trace routing.

Figure 24 illustrates a way of creating isolated power sources using beads on surface traces. No power or ground plane partitioning is implied or required.

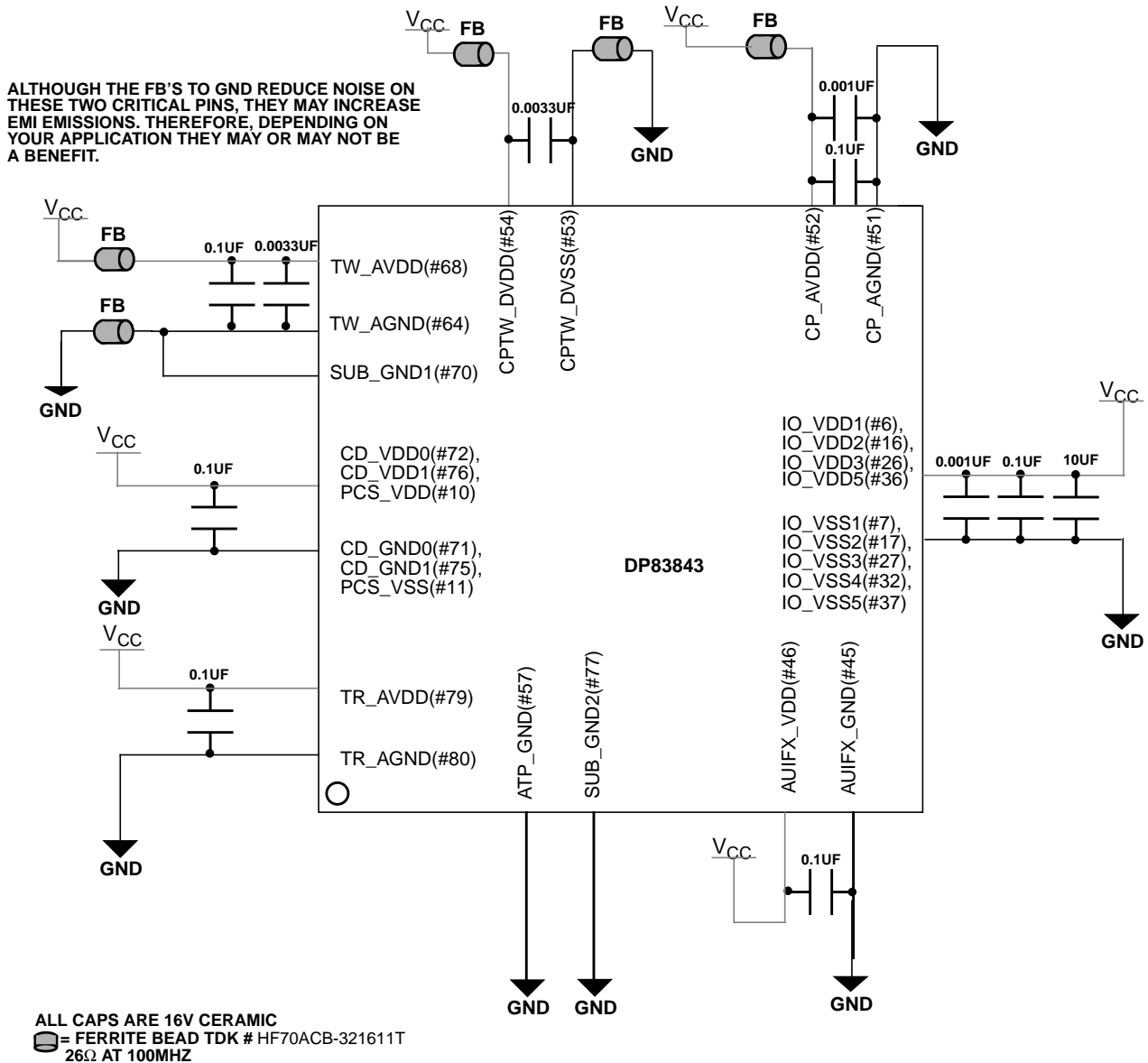

Figure 23. Power and Ground Filtering for the DP83843

6.0 DP83843 Application (Continued)

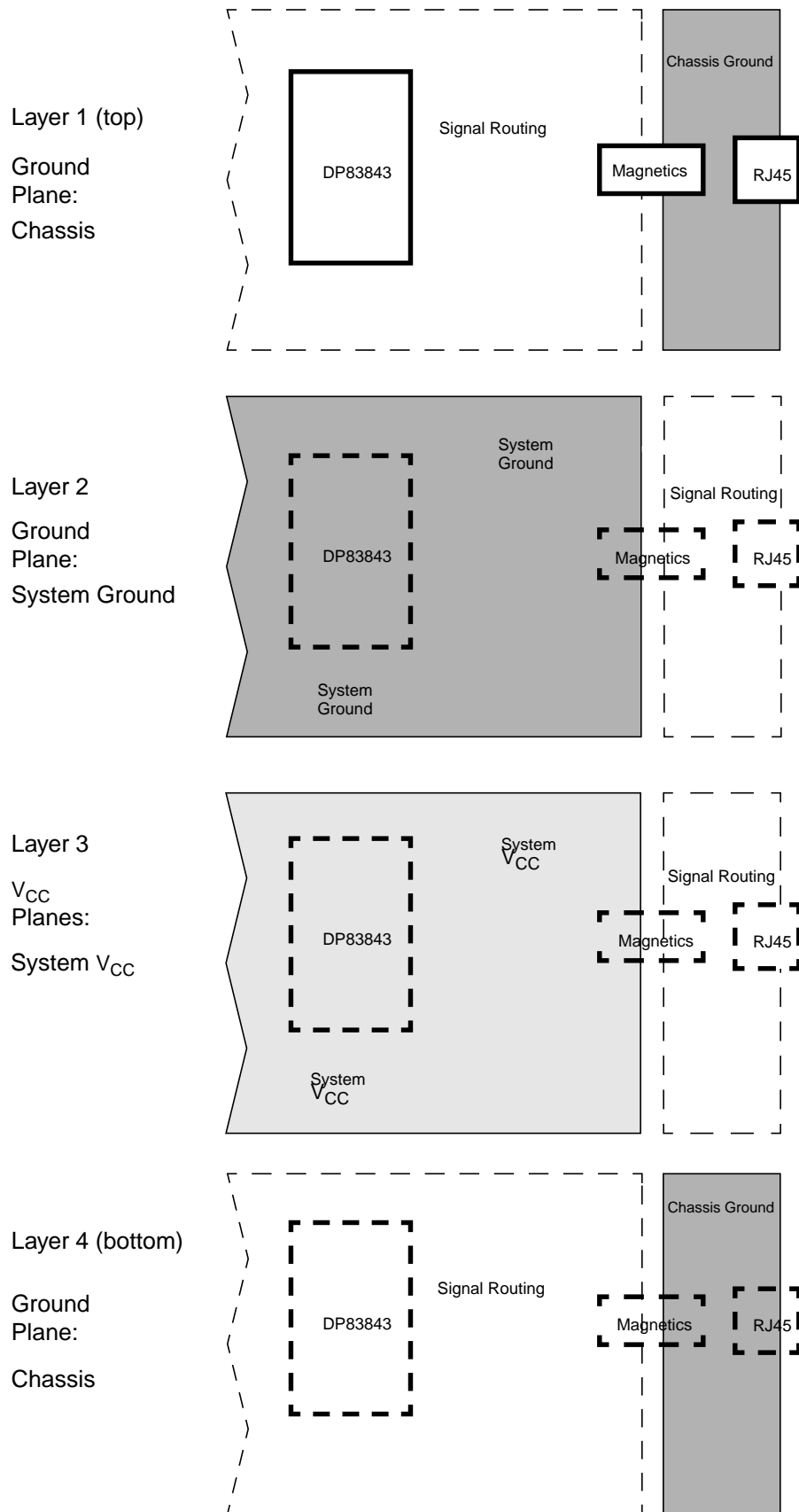

Figure 24. Typical plane layout recommendation for DP83843

6.0 DP83843 Application (Continued)

6.3.1 ESD Protection

Typically, ESD precautions are predominantly in effect when handling the devices or board before being installed in a system. In those cases, strict handling procedures can be implemented during the manufacturing process to greatly reduce the occurrences of catastrophic ESD events. After the system is assembled, internal components are usually relatively immune from ESD events.

In the case of an installed Ethernet system however, the network interface pins are still susceptible to external ESD events. For example, a category 5 cable being dragged across a carpet has the potential of developing a charge well above the typical 2kV ESD rating of a semiconductor device.

For applications where high reliability is required, it is recommended that additional ESD protection diodes be added as shown below. There are numerous dual series connected diode pairs that are available specifically for ESD protection. The level of protection will vary dependent upon the diode ratings. The primary parameter that affects the level of ESD protection is peak forward surge current. Typical specifications for diodes intended for ESD protection range from 500mA (Motorola BAV99LT1 single pair diodes) to 12A (STM DA108S1 Quad pair array).

Since performance is dependent upon components used, board impedance characteristics, and layout, the circuit should be completely tested to ensure performance to the required levels.

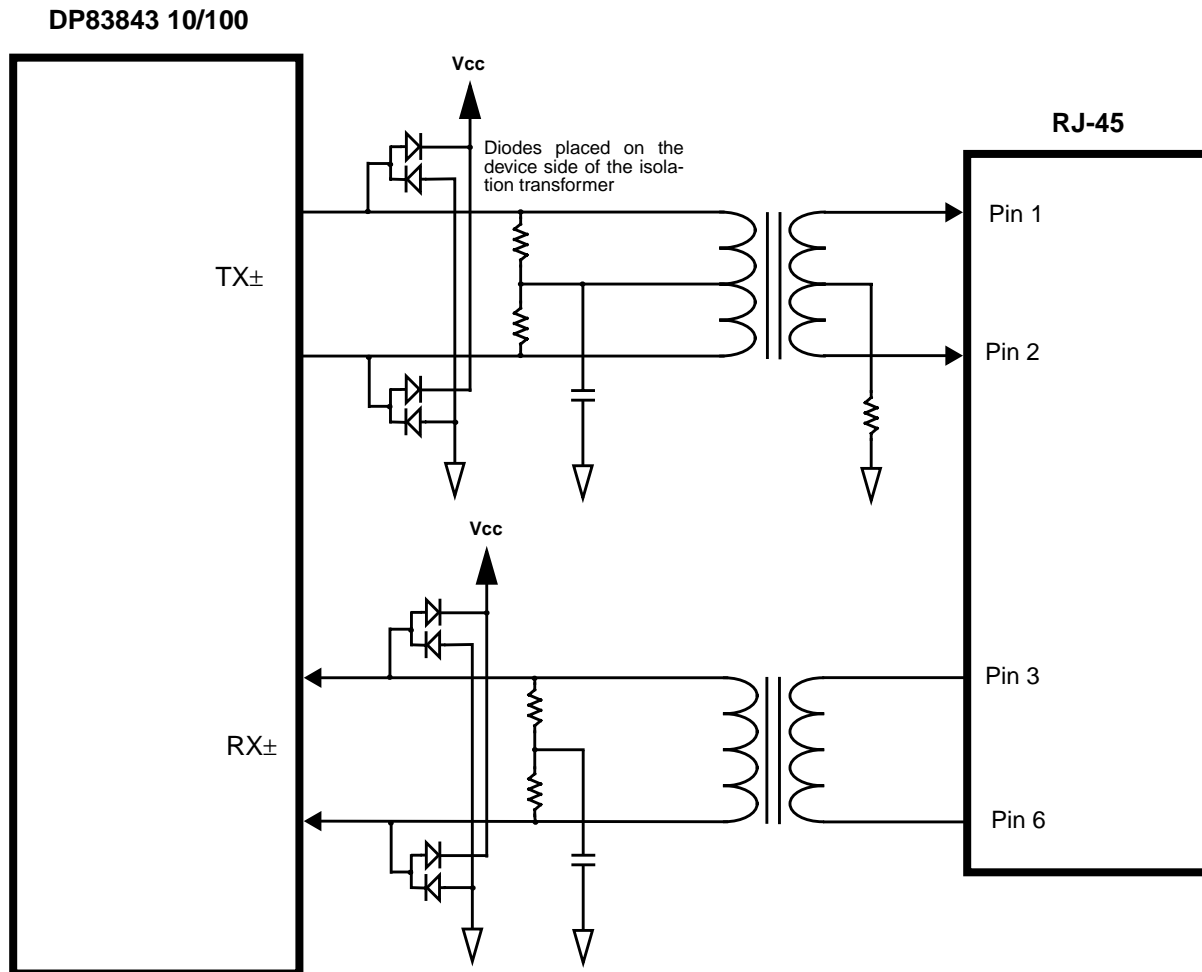

Figure 25. Typical DP83843 Network Interface with additional ESD protection

7.0 User Information

7.1 Link LED While in Force 100Mb/s Good Link

Type:

Information Hardware

Problem:

The Good Link LED (LED_LINK pin 39) will not assert when the DP83843BVJE is programmed to force good link in 100Mb/s mode. However, as long as the DP83843BVJE is configured for forced 100BASE-X operation and good link is forced for 100M operation, it will still be able to transmit data even though the good link LED is not lit.

Description:

When the DP83843BVJE is configured for forced good link in 100Mb/s mode, by setting bit 6 of the PCS register (address 16h), the LINK_LED pin will not assert unless an internal state machine term, referred to as Cipher_In_Sync (aka CIS), is asserted. The assertion of CIS is based on the receive descrambler either being bypassed or becoming synchronized with the receive scrambled data stream.

As long as the DP83843BVJE is configured for forced 100BASE-X operation however, setting bit 6 of the PCS register (address 16h) will allow for transmission of data.

Solution / Workaround:

In order to assert the Link LED while in Forced Good Link 100Mb/s mode, the user may select one of two options:

1: After setting bit 6 of the PCS register (address 16h), the user may connect the DP83843BVJE to a known good far-end link partner that is transmitting valid scrambled IDLEs. This will assert the internal CIS term and, in turn, assert the Link LED.

2: After setting bit 6 of the PCS register (address 16h), the user may then assert bit 12 of the LBR register (address 17h) to bypass the scrambler/descrambler. This will assert the internal CIS term and, in turn, assert the Link LED. The user should then clear bit 12 of the LBR register (address 17h) to re-engage the scrambler/descrambler to allow for normal scrambled operation while in forced good link 100Mb/s mode.

7.2 False Link Indication When in Forced 10Mb/s

Type:

Informational Hardware

Problem:

The DP83843BVJE will indicate valid link status when forced to 10Mb/s (without Auto-Negotiation) while receiving 100BASE-TX scrambled Idles.

Description:

The DP83843BVJE can incorrectly identify 100BASE-TX scrambled Idles being received as valid 10BASE-T energy and consequently indicate a valid link by the assertion of the Link LED as well as by setting the Link Status bit (bit 2) in the BMSR (reg 01h).

Solution / Workaround:

Do not force 10Mb/s operation. Instead, use Auto-Negotiation to advertise 10BASE-T full and/or half duplex (as desired) via the ANAR register (reg 04h)

By using Auto-Negotiation and only specifying 10BASE-T (either half or full duplex), the DP83843BVJE will recognize the scrambled idles as a valid 100Mb/s stream, but it will

not complete the negotiation since it is not advertising 100Mb/s capability. In an application in which the user only desires 10Mb/s operation and is being sent 100Mb/s signals, then the correct operation is to never complete the negotiation.

7.3 10Mb/s Repeater Mode

Type:

Urgent Hardware

Problem:

The DP83843BVJE is not designed to support the use of certain AUI attachments in repeater applications nor will it directly support 10Mb/s repeater applications while in 10Mb/s serial or nibble mode.

Description:

When implementing repeater applications which include a Coaxial Transceiver Interface (CTI) connected to the DP83843 AUI interface, CRS will be asserted due to transmit data because the transmit data is looped back to the receive channel at the CTI transceiver. The assertion of CRS during transmit will result in undue collisions at the repeater controller.

Additionally, because there is no way to guarantee phase alignment of the 10MHz TX_CLK between multiple PHYTERs in a serial 10M repeater application (same is true for 2.5MHz TX_CLK in 10Mb/s nibble mode), assuming each PHYTER is referenced to a single 25MHz X1 clock signal, it is impossible to meet the input set and hold requirements across all ports during a transmit operation.

Solution:

It is not recommended that the DP83843BVJE be used for AUI repeater applications where the transmit data is looped back to the receive channel at the transceiver. (i.e. CTI). Additionally, 10M serial and nibble repeater applications are not currently directly supported.

7.4 Resistor Value Modifications

Type:

Urgent Hardware

Problem:

To ensure optimal performance, the DP83843BVJE bandgap reference and receive equalization reference resistor values require updating.

Description:

The internal bandgap reference of the DP83843BVJE is slightly offset which results in an offset in various IEEE conformance parameters such as VOD.

The internal adaptive equalization reference bias is also slightly offset which can result in slightly reduced maximum cable length performance.

Solution / Workaround:

In order to set the proper internal bandgap reference, it is recommended that the value of the resistor connected to the BGREF pin (pin 61) be set to 4.87K Ω (1/10th Watt resistor with a 1% tolerance is recommended). This resistor should be connected between the BGREF pin and TW_AGND.

In order to ensure maximum cable length performance for 100BASE-TX operation, it is recommended that a 70K Ω

resistor be placed between the TWREF pin (pin 60) and TW_AGND. (1/10th Watt resistor with a 1% tolerance is recommended)

7.5 Magnetics

Type:

Informational Hardware

Problem:

N/A

Description:

The DP83843BVJE has been extensively tested with the following single package magnetics:

Valor PT4171 and ST6118

Bel Fuse S558-5999-39

Pulse H1086

Solution / Workaround:

Please note that one of the most important parameters that is directly affected by the magnetics is 100BASE-TX Output Transition Timing. Even with the Valor PT4171S magnetics, it is possible, depending on the system design, layout, and associated parasitics, the output transition times may need to be further controlled.

In order to help control the output transition time of the 100BASE-TX transmit signal, the user may wish to place a capacitive load across the TPTD+/- pins as close to these pins as possible. However, because every system is different, it is suggested that the system designer experiment with the capacitive value in order to obtain the desired results.

Note that the board layout, the magnetics, and the output signal of the DP83843BVJE each contribute to the final rise and fall times as measured across the RJ45-8 transmit pins. It should be noted that excessive capacitive loading across the TPTD+/- pins may result in improper transmit return loss performance at high frequencies (up to 80MHz). Finally, when performing 100Mb/s transmit return loss measurements, it is recommended that the DP83843BVJE be placed in True Quiet mode as described here:

In order to configure the PHYTER for "True Quiet" operation, the following software calls should occur via the serial MII management port following normal initialization of the device:

- Write 01h to register 1Fh (this enables the extended register set)
- Write 02h to register 05h (this disables the NRZI encoder, required for True Quiet)
- write 00h to register 1Fh (this exits the extended register set)
- Set bit 9 of register 16h (this enables TX_QUIET which stops transmitting 100M IDLEs))

7.6 Next Page Toggle Bit Initialization

Type:

Urgent Software

Problem:

The DP83843BVJE's Next Page Toggle bit initializes to 0 independent of the value programmed in bit 11 of the Advertised Abilities Register (ANAR), Reg 4h

Description:

The Next Page Toggle bit is used only in Next Page operations, and is used to distinguish one page from another. The AutoNegotiation specification indicates that the toggle bit should take on an initial value equal to that of bit 11 in the ANAR, Reg 4h.

The DP83843BVJE incorrectly initializes this bit to 0, independent of the setting of bit 11 in the ANAR. Note that this bit is a RESERVED bit in the 802.3 specification, and defaults to 0 for all combinations of strap options.

If the user were to program both the Next Page bit, bit 15, and the RESERVED bit, bit 11, to a logic 1 to perform a next page type negotiation, and the partner node also supported next page operation, then the negotiation would not complete due to the initial wrong polarity of the toggle bit.

Solution / Workaround:

Do not set RESERVED bit 11 (reg 04h) to a logic 1 if you plan to perform next page operations.

7.7 Base Page to Next Page Initial FLP Burst Spacing

Type:

Informational Hardware

Problem:

In performing Next Page Negotiation, the FLP burst spacing on the initial burst when changing from the Base Page to the Next Page can be as long as 28ms. The 802.3u specification, Clause 28 sets a maximum of 22.3ms. Thus, there is a potential violation of 5.7ms.

Description:

This anomaly is due to the handshake between the arbitration and transmit state machines within the device. All other FLP burst to burst spacings, either base page or next page, will be in the range of 13ms to 15ms.

Note that the violating burst causes NO functional problems for either base page or next page exchange. This is due to the fact that the nlp_test_max_timer in the receive state machine has a minimum specification of 50ms, and the nlp_test_min_timer has a minimum specification of 5ms. Thus, even if the transmitter waits 28ms vs. 22.3ms between FLP bursts, the nlp_test_max_timer will not have come close to expiring. $(50 + 5 - 28) = 27\text{ms}$ slack time.

Solution.

NOT APPLICABLE, Not a functional problem

7.8 100Mb/s FLP Exchange Followed by Quiet

Type:

Informational Hardware

Problem:

The scenario is when the DP83843BVJE and another station are BOTH using AutoNegotiation AND advertising 100mb full or half. If both units complete the FLP exchange properly, but the partner does NOT send any idles (a FAULT condition), then the DP83843BVJE will get into a state in which it constantly sends 100mb idles and looks for 100mb idles from the partner.

Description:

The symptoms of this problem include:

Register 1: Will show negotiation NOT complete (bit 5 = 0)

Register 6: Will show a page received, then page receive will be cleared on read of this register (bit 1 = 1, then bit 1 = 0 if read twice)

Register 1a: Will have the data 00a3

Solution / Workaround:

The workarounds include (these are mutually exclusive):

1. Provide a 100mb data stream to the DP83843BVJE (fix the problem)
2. Force 10mb mode by writing 0000h (half10) or 0100 (full10) to Register 0. This is a logical progression since the 100mb side of the partner logic is down.
3. If you want to run AutoNegotiation again, with reduced capabilities or all capabilities:

Turn off AutoNegotiation by writing a 0000h to Register 0. (Need to do this to clear the DP83843 from sending idles.)

Change the capabilities to the desired configuration by writing to Register 4 (0061 for full10/half10, or 0021 for half10 only, etc.)

Enable AutoNegotiation by writing a 1200 to Register 0. (This restarts AutoNegotiation as well)

7.9 Common Mode Capacitor for EMI improvement**Type:**

Informational Hardware

Problem:

As with any high-speed design it is always practical to take precautions regarding the design and layout of a system to attempt to ensure acceptable EMI performance.

Description:

In an attempt to improve the EMI performance of a DP83843BVJE based PCI Node Card, a 10pF capacitor was installed from the center-tap of the primary winding of the transmit transformer to gnd. This common mode capacitive filtering improved (reduced) the EMI emissions by several dB at critical frequencies when tested in an FCC certified open field test site.

Solution / Workaround:

It is recommended that the footprint for a typical ceramic chip cap be included on all new DP83843BVJE based designs to allow for the experimentation of EMI improvement. Again, a component footprint for the 10pF capacitor should be installed from the center-tap of the primary winding of the transmit transformer to system gnd. The inclusion of this capacitor should have no deleterious effect on the differential signalling of the transmitted signal. In fact, because of the unique current source transmitter of the DP83843BVJE, this center-tap cap has been shown to actually improve some of the signal characteristics such as rise/fall times and transmit return loss.

When including this component in a given design, it is recommended that it be connected from the transmit transformer primary center-tap directly to ground with an absolute minimum of routing (preferably just an immediate via to the ground plane).

7.10 BAD_SSD Event Lockup**Type:**

Urgent Hardware

Problem:

When the PHYTER receives a particular invalid data sequence, it can get stuck in the RX_DATA state with an invalid alignment. It will not recover until the link is broken or software intervenes. The required data sequence looks like a bad_ssd event (I,J, followed by symbol with MSB=0), followed eventually by a good IJK pattern before seeing 10 consecutive idle bits. The data pattern also has to show up on a specific alignment.

Description:

Root cause is that the transition from BAD_SSD state to the CARRIER_DET state, which can only occur if there is a single IDLE between packets, does not cause a re-loading of the data alignment. If the Bad SSD event which preceded this met certain conditions defined above, then the alignment logic is in an invalid state and the state machine will not be able to detect an end of frame condition.

Solution:

There is no workaround available. Since the data pattern should never occur on a normally operating network, it has been decided that no corrective action is required for the current product.

8.0 Register Block

8.1 Register Definitions

Register maps and address definitions are given in the following tables:

Table 5. Register Block - Phyter Register Map

Offset	Access	Tag	Description
00h	RW	BMCR	Basic Mode Control Register
01h	RO	BMSR	Basic Mode Status Register
02h	RO	PHYIDR1	PHY Identifier Register #1
03h	RO	PHYIDR2	PHY Identifier Register #2
04h	RW	ANAR	Auto-Negotiation Advertisement Register
05h	RW	ANLPAR	Auto-Negotiation Link Partner Ability Register
06h	RW	ANER	Auto-Negotiation Expansion Register
07h	RW	ANNPTR	Auto-Negotiation Next Page TX
08h-0Fh		Reserved	Reserved
10h	RO	PHYSTS	PHY Status Register
11h	RW	MIPSCR	MII Interrupt PHY Specific Control Register
12h	RO	MIPGSR	MII Interrupt PHY Generic Status Register
13h	RW	DCR	Disconnect Counter Register
14h	RW	FCSCR	False Carrier Sense Counter Register
15h	RW	RECR	Receive Error Counter Register
16h	RW	PCSR	PCS Sub-Layer Configuration and Status Register
17h	RW	LBR	Loopback and Bypass Register
18h	RW	10BTSCR	10BASE-T Status & Control Register
19h	RW	PHYCTRL	PHY Control Register
1Ah-1Fh		Reserved	Reserved

In the register definitions under the 'Default' heading, the following definitions hold true:

- RW = Read/Write; Register bit is able to be read and written to by software
- RO = Read Only; Register bit is able to be read but not written to by software
- L(H) = Latch/Hold; Register bit is latched and held until read by software based upon the occurrence of the corresponding event
- SC = Self Clear; Register bit will clear itself after the event has occurred without software intervention
- P = Permanent; Register bit is permanently set to the default value and no action will cause the bit to change

8.0 Register Block (Continued)

Table 6. Basic Mode Control Register (BMCR) Address 00h

Bit	Bit Name	Default	Description
15	Reset	0, RW/SC	<p>Reset: 1 = Initiate software Reset / Reset in Process 0 = Normal operation</p> <p>This bit sets the status and control registers of the PHY to their default states. This self-clearing bit returns a value of one until the reset process is complete (approximately 1.2 ms for reset duration). Reset is finished once the Auto-Negotiation process has begun or the device has entered its forced mode.</p>
14	Loopback	0, RW	<p>Loopback: 1 = Loopback enabled 0 = Normal operation</p> <p>The loopback function enables MII transmit data to be routed to the MII receive data path.</p> <p>Setting this bit may cause the descrambler to lose synchronization and produce a 500 μs "dead time" before any valid data will appear at the MII receive outputs.</p>
13	Speed Selection	Strap, RW	<p>Speed Select: 1 = 100 Mb/s 0 = 10 Mb/s</p> <p>Link speed is selected by this bit or by Auto-Negotiation if bit 12 of this register is set (in which case, the value of this bit is ignored)</p> <p>At reset, this bit is set according to the strap configuration of the AN0 and AN1 pins. After reset, this bit may be written to by software.</p>
12	Auto-Negotiation Enable	Strap, RW	<p>Auto-Negotiation Enable: 1 = Auto-Negotiation Enabled - bits 8 and 13 of this register are ignored when this bit is set. 0 = Auto-Negotiation Disabled - bits 8 and 13 determine the link speed and mode.</p> <p>At reset, this bit is set according to the strap configuration of the AN0 and AN1 pins. After reset, this bit may be written to by software.</p>
11	Power Down	0, RW	<p>Power Down: 1 = Power Down 0 = Normal Operation</p> <p>Setting this bit configures the PHYTER for minimum power requirements. While in Power Down mode, the PHYTER is not capable of transmitting or receiving data on an active network. Additionally, the PHYTER is not capable of "Wake-on-LAN" and will not react to receive data while in Power Down mode. Power Down mode is useful for scenarios where minimum system power is desired (ie. Green PCs) but can only be used in systems that have control over the PHYTER via Serial MII management.</p>

8.0 Register Block (Continued)

Table 6. Basic Mode Control Register (BMCR) Address 00h (Continued)

Bit	Bit Name	Default	Description
10	Isolate	Strap, RW	<p>Isolate:</p> <p>1 = Isolates the DP83843 from the MII with the exception of the serial management. When this bit is asserted, the DP83843 does not respond to TXD[3:0], TX_EN, and TX_ER inputs, and it presents a high impedance on its TX_CLK, RX_CLK, RX_DV, RX_ER, RXD[3:0], COL and CRS outputs.</p> <p>0 = Normal operation</p> <p>If the PHY address is set to "00000" at power-up/reset the isolate bit will be set to one, otherwise it defaults to 0. After reset this bit may be written to by software.</p>
9	Restart Auto-Negotiation	0, RW/SC	<p>Restart Auto-Negotiation:</p> <p>1 = Restart Auto-Negotiation. Re-initiates the Auto-Negotiation process. If Auto-Negotiation is disabled (bit 12 of this register cleared), this bit has no function and should be cleared. This bit is self-clearing and will return a value of 1 until Auto-Negotiation is initiated by the Device, whereupon it will self-clear. Operation of the Auto-Negotiation process is not affected by the management entity clearing this bit.</p> <p>0 = Normal operation</p>
8	Duplex Mode	Strap, RW	<p>Duplex Mode:</p> <p>1 = Full Duplex operation. Duplex selection is allowed when Auto-Negotiation is disabled (bit 12 of this register is cleared).</p> <p>0 = Half Duplex operation</p> <p>At reset this bit is set by either AN0 or AN1. After reset this bit may be written to by software.</p>
7	Collision Test	0, RW	<p>Collision Test:</p> <p>1 = Collision test enabled</p> <p>0 = Normal operation</p> <p>When set, this bit will cause the COL signal to be asserted in response to the assertion of TX_EN within 512BT. The COL signal will be de-asserted within 4BT in response to the de-assertion of TX_EN.</p>
6:0	Reserved	0, RO	Reserved: Write ignored, read as zero

Table 7. Basic Mode Status Register (BMSR) Address 01h

Bit	Bit Name	Default	Description
15	100BASE-T4	0, RO/P	<p>100BASE-T4 Capable:</p> <p>1 = Device able to perform in 100BASE-T4 mode</p> <p>0 = Device not able to perform in 100BASE-T4 mode</p> <p>The PHYTER is NOT capable of supporting 100BASE-T4 and this bit is permanently set to 0.</p>
14	100BASE-TX Full Duplex	1, RO/P	<p>100BASE-TX Full Duplex Capable:</p> <p>1 = Device able to perform 100BASE-TX in full duplex mode</p> <p>0 = Device not able to perform 100BASE-TX in full duplex mode</p>
13	100BASE-TX Half Duplex	1, RO/P	<p>100BASE-TX Half Duplex Capable:</p> <p>1 = Device able to perform 100BASE-TX in half duplex mode</p> <p>0 = Device not able to perform 100BASE-TX in half duplex mode</p>

8.0 Register Block (Continued)

Table 7. Basic Mode Status Register (BMSR) Address 01h (Continued)

Bit	Bit Name	Default	Description
12	10BASE-T Full Duplex	1, RO/P	10BASE-T Full Duplex Capable: 1 = Device able to perform 10BASE-T in full duplex mode 0 = Device not able to perform 10BASE-T in full duplex mode
11	10BASE-T Half Duplex	1, RO/P	10BASE-T Half Duplex Capable: 1 = Device able to perform 10BASE-T in half duplex mode 0 = Device not able to perform 10BASE-T in half duplex mode
10:7	Reserved	0, RO	Reserved: Write as 0, read as 0
6	Preamble Suppression	1, RO/P	Preamble suppression Capable: 1 = Device able to perform management transaction with preamble suppressed* 0 = Device not able to perform management transaction with preamble suppressed * Need minimum of 32 bits of preamble after reset.
5	Auto-Negotiation Complete	0, RO	Auto-Negotiation Complete: 1 = Auto-Negotiation process complete 0 = Auto-Negotiation process not complete
4	Remote Fault	0, RO/LH	Remote Fault: 1 = Remote Fault condition detected (cleared on read or by a chip reset). Fault criteria is Far End Fault Isolation or notification from Link Partner of Remote Fault. 0 = No remote fault condition detected
3	Auto-Negotiation Ability	1, RO/P	Auto Configuration Ability: 1 = Device is able to perform Auto-Negotiation 0 = Device is not able to perform Auto-Negotiation
2	Link Status	0, RO/L	Link Status: 1 = Valid link established (for either 10 or 100 Mb/s operation) 0 = Link not established The criteria for link validity is implementation specific. The link status bit is implemented with a latching function, so that the occurrence of a link failure condition causes the Link Status bit to become cleared and remain cleared until it is read via the management interface.
1	Jabber Detect	0, RO/L	Jabber Detect: 1 = Jabber condition detected 0 = No Jabber This bit is implemented with a latching function so that the occurrence of a jabber condition causes it to become set until it is cleared by a read to this register by the management interface or by a Device Reset. This bit only has meaning in 10 Mb/s mode.
0	Extended Capability	1, RO/P	Extended Capability: 1 = Extended register capable 0 = Basic register capable only

8.0 Register Block (Continued)

The PHY Identifier Registers #1 and #2 together form a unique identifier for the DP83843. The Identifier consists of a concatenation of the Organizationally Unique Identifier (OUI), the vendor's model number and the model revision number. A PHY may return a value of zero in each of the 32 bits of the PHY Identifier if desired. The PHY Identifier is intended to support network management. National's IEEE assigned OUI is 080017h.

Table 8. PHY Identifier Register #1 (PHYIDR1) Address 02h

Bit	Bit Name	Default	Description
15:0	OUI_MSB	<00 1000 0000 0000 00>, RO/P	OUI Most Significant Bits: This register stores bits 3 to 18 of the OUI (080017h) to bits 15 to 0 of this register respectively. The most significant two bits of the OUI are ignored (the IEEE standard refers to these as bits 1 and 2).

Table 9. PHY Identifier Register #2 (PHYIDR2) Address 03h

Bit	Bit Name	Default	Description
15:10	OUI_LSB	<01 0111>, RO/P	OUI Least Significant Bits: Bits 19 to 24 of the OUI (080017h) are mapped to bits 15 to 10 of this register respectively.
9:4	VNDR_MDL	<00 0001>, RO/P	Vendor Model Number: Six bits of vendor model number mapped to bits 9 to 4 (most significant bit to bit 9).
3:0	MDL_REV	<0000>, RO/P	Model Revision Number: Four bits of vendor model revision number mapped to bits 3 to 0 (most significant bit to bit 3). This field will be incremented for all major device changes.

This register contains the advertised abilities of this device as they will be transmitted to its Link Partner during Auto-Negotiation.

Table 10. Auto-Negotiation Advertisement Register (ANAR) Address 04h

Bit	Bit Name	Default	Description
15	NP	0, RW	Next Page Indication: 0 = Next Page Transfer not desired 1 = Next Page Transfer desired
14	Reserved	0, RO/P	Reserved by IEEE: Writes ignored, Read as 0
13	RF	0, RW	Remote Fault: 1 = Advertises that this device has detected a Remote Fault 0 = No Remote Fault detected
12:11	Reserved	0, RW	Reserved for Future IEEE use: Write as 0, Read as 0
10	FDFC	0, RW	Full Duplex Flow Control: 1 = Advertise that the DTE(MAC) has implemented both the optional MAC control sublayer and the pause function as specified in clause 31 and annex 31B of 802.3u 0 = No MAC based full duplex flow control
9	T4	0, RO/P	100BASE-T4 Support: 1 = 100BASE-T4 is supported by the local device 0 = 100BASE-T4 not supported
8	TX_FD	Strap, RW	100BASE-TX Full Duplex Support: 1 = 100BASE-TX Full Duplex is supported by the local device 0 = 100BASE-TX Full Duplex not supported At reset, this bit is set by AN0/AN1. After reset, this bit may be written to by software.

8.0 Register Block (Continued)

Table 10. Auto-Negotiation Advertisement Register (ANAR) Address 04h (Continued)

Bit	Bit Name	Default	Description
7	TX	Strap, RW	100BASE-TX Support: 1 = 100BASE-TX is supported by the local device 0 = 100BASE-TX not supported At reset, this bit is set by AN0/AN1. After reset, this bit may be written to by software.
6	10_FD	Strap, RW	10BASE-T Full Duplex Support: 1 = 10BASE-T Full Duplex is supported by the local device 0 = 10BASE-T Full Duplex not supported At reset, this bit is set by AN0/AN1. After reset, this bit may be written to by software.
5	10	Strap, RW	10BASE-T Support: 1 = 10BASE-T is supported by the local device 0 = 10BASE-T not supported At reset, this bit is set by AN0/AN1. After reset, this bit may be written to by software.
4:0	Selector	<00001>, RW	Protocol Selection Bits: These bits contain the binary encoded protocol selector supported by this node. <00001> indicates that this device supports IEEE 802.3 CSMA/CD.

Advertised abilities of the Link Partner as received during Auto-Negotiation.

Table 11. Auto-Negotiation Link Partner Ability Register (ANLPAR) Address 05h

Bit	Bit Name	Default	Description
15	NP	0, RO	Next Page Indication: 0 = Link Partner does not desire Next Page Transfer 1 = Link Partner desires Next Page Transfer
14	ACK	0, RO	Acknowledge: 1 = Link Partner acknowledges reception of the ability data word 0 = Not acknowledged The Device's Auto-Negotiation state machine will automatically control the use of this bit from the incoming FLP bursts. Software should not attempt to write to this bit.
13	RF	0, RO	Remote Fault: 1 = Remote Fault indicated by Link Partner 0 = No Remote Fault indicated by Link Partner
12:10	Reserved	0, RO	Reserved for Future IEEE use: Write as 0, read as 0
9	T4	0, RO	100BASE-T4 Support: 1 = 100BASE-T4 is supported by the Link Partner 0 = 100BASE-T4 not supported by the Link Partner
8	TX_FD	0, RO	100BASE-TX Full Duplex Support: 1 = 100BASE-TX Full Duplex is supported by the Link Partner 0 = 100BASE-TX Full Duplex not supported by the Link Partner
7	TX	0, RO	100BASE-TX Support: 1 = 100BASE-TX is supported by the Link Partner 0 = 100BASE-TX not supported by the Link Partner

8.0 Register Block (Continued)

Table 11. Auto-Negotiation Link Partner Ability Register (ANLPAR) Address 05h

Bit	Bit Name	Default	Description
6	10_FD	0, RO	10BASE-T Full Duplex Support: 1 = 10BASE-T Full Duplex is supported by the Link Partner 0 = 10BASE-T Full Duplex not supported by the Link Partner
5	10	0, RO	10BASE-T Support: 1 = 10BASE-T is supported by the Link Partner 0 = 10BASE-T not supported by the Link Partner
4:0	Selector	<00000>, RO	Protocol Selection Bits: Link Partners's binary encoded protocol selector.

8.0 Register Block (Continued)

Table 11. Auto-Negotiation Link Partner Ability Register (ANLPAR) Address 05h

Bit	Bit Name	Default	Description
This register also contains the Link Partner Next Page contents.			
15	NP	X RO	Next Page Indication: 0 = Link Partner does not desire another Next Page Transfer 1 = Link Partner desires another Next Page Transfer
14	ACK	X, RO	Acknowledge: 1 = Link Partner acknowledges reception of the ability data word 0 = Not acknowledged The Device's Auto-Negotiation state machine will automatically control the use of this bit from the incoming FLP bursts. Software should not attempt to write to this bit.
13	MP	X, RO	Message Page: 1 = Message Page 0 = Unformatted Page
12	ACK2	X, RO	Acknowledge 2: 0 = Link Partner does not have the ability to comply to next page message 1 = Link Partner has the ability to comply to next page message
11	TOGGLE	X, RO	Toggle: 0 = Previous value of the transmitted Link Code word equalled logic one 1 = Previous value of the transmitted Link Code word equalled logic zero
10:0	CODE	XXX, RW	This field represents the code field of the next page transmission. If the MP bit is set (bit 13 of this register), then the code shall be interpreted as a "Message Page," as defined in annex 28C of Clause 28. Otherwise, the code shall be interpreted as an "Unformatted Page," and the interpretation is application specific.

Table 12. Auto-Negotiation Expansion Register (ANER) Address 06h

Bit	Bit Name	Default	Description
15:5	Reserved	0, RO	Reserved: Writes ignored, Read as 0.
4	PDF	0, RO	Parallel Detection Fault: 1 = A fault has been detected via the Parallel Detection function 0 = A fault has not been detected via the Parallel Detection function
3	LP_NP_ABLE	0, RO	Link Partner Next Page Able: Status indicating if the Link Partner supports Next Page negotiation. A one indicates that the Link Partner does support Next Page.
2	NP_ABLE	1, RO/P	Next Page Able: Indicates if this node is able to send additional "Next Pages."
1	PAGE_RX	0, RO/L	Link Code Word Page Received: This bit is set when a new Link Code Word Page has been received. Cleared on read of this register.
0	LP_AN_ABLE	0, RO	Link Partner Auto-Negotiation Able: A one in this bit indicates that the Link Partner supports Auto-Negotiation.

8.0 Register Block (Continued)

This register contains the next page information sent by this device to its Link Partner during Auto-Negotiation.

Table 13. Auto-Negotiation Next Page Transmit Register (ANNPTR) Address 07h

Bit	Bit Name	Default	Description
15	NP	0, RW	Next Page Indication: 0 = No other Next Page Transfer desired 1 = Another Next Page desired
14	Reserved	0, RO	Reserved: Writes ignored, read as 0
13	MP	1, RW	Message Page: 1 = Message Page 0 = Unformatted Page
12	ACK2	0, RW	Acknowledge2: 1 = Will comply with message 0 = Cannot comply with message Acknowledge2 is used by the next page function to indicate that a device has the ability to comply with the message received.
11	TOG_TX	1, RO	Toggle: 1 = Previous value of transmitted Link Code Word equalled logic 0 0 = Previous value of transmitted Link Code Word equalled logic 1 Toggle is used by the Arbitration function within Auto-Negotiation to ensure synchronization with the Link Partner during Next Page exchange. This bit shall always take the opposite value of the Toggle bit in the previously exchanged Link Code Word. The initial value is the inverse of bit 11 in the base Link Code Word (ANAR), which makes the default value of TOG_TX = 1.
10:0	CODE	001, RW	This field represents the code field of the next page transmission. If the MP bit is set (bit 13 of this register), then the code shall be interpreted as a "Message Page," as defined in annex 28C of Clause 28. Otherwise, the code shall be interpreted as an "Unformatted Page," and the interpretation is application specific. The default value of the CODE represents a Null Page as defined in annex 28C of Clause 28.

8.0 Register Block (Continued)

This register provides a single location within the register set for quick access to commonly accessed information.

Table 14. PHY Status Register (PHYSTS) Address 10h

Bit	Bit Name	Default	Description
15	Receive Error Latch	0, RO/L	Receive Error Latch: 1 = Receive error event has occurred since last read of RXERCNT 0 = No receive error event has occurred
14	CIM Latch	0, RO/L	Carrier Integrity Monitor Latch: 1 = Carrier Integrity Monitor has found an isolate event since last read of DCR 0 = No Carrier Integrity Monitor isolate event has occurred
13	False Carrier Sense Latch	0, RO/L	False Carrier Sense Latch: 1 = False Carrier event has occurred since last read of FCSCR 0 = No False Carrier event has occurred
12	Reserved	0, RO	Reserved: Write ignored, read as 0.
11	Device Ready	0, RO	Device Ready: This bit signifies that the device is now ready to transmit data. 1 = Device Ready 0 = Device not Ready
10	Page Received	0, RO/L	Link Code Word Page Received: This bit is set when a new Link Code Word Page has been received. Cleared on read of the ANER register.
9	Auto-Negotiation Enabled	Strap, RO	Auto-Negotiation Enabled: 1 = Auto-Negotiation Enabled. 0 = Auto-Negotiation Disabled.
8	MII Interrupt	0, RO/L	MII Interrupt Pending: Indicates that an internal interrupt is pending and is cleared by the current read. A read of this bit will clear the bit in the MIPGSR (12h) also.
7	Remote Fault	0, RO/L	Remote Fault: 1 = Remote Fault condition detected (cleared on read of BMSR register or by a chip reset). Fault criteria is Far end Fault Isolation or notification from Link Partner of Remote Fault. 0 = No remote fault condition detected
6	Jabber Detect	0, RO/L	Jabber Detect: 1 = Jabber condition detected 0 = No Jabber This bit is implemented with a latching function so that the occurrence of a jabber condition causes it to become set until it is cleared by a read to the BMSR register by the management interface or by a Device reset. This bit only has meaning in 10 Mb/s mode.
5	NWAY Complete	0, RO	Auto-Negotiation Complete: 1 = Auto-Negotiation complete 0 = Auto-Negotiation not complete
4	Reset Status	0, RO	Reset Status: 0 = Normal operation 1 = Reset in progress

8.0 Register Block (Continued)

Table 14. PHY Status Register (PHYSTS) Address 10h (Continued)

Bit	Bit Name	Default	Description
3	Loopback Status	0, RO	Loopback: 1 = Loopback enabled 0 = Normal operation
2	Duplex Status	RO	Duplex: This bit indicates duplex status and is determined from Auto-Negotiation or Forced Modes. 1 = Running in Full duplex mode 0 = Running in Half duplex mode Note: This bit is only valid if Auto-Negotiation is enabled and complete and there is a valid link or if Auto-Negotiation is disabled and there is a valid link.
1	Speed Status	RO	Speed10: This bit indicates the status of the speed and is determined from Auto-Negotiation or Forced Modes. 1 = Running in 10Mb/s mode 0 = Running in 100 Mb/s mode Note: This bit is only valid if Auto-Negotiation is enabled and complete and there is a valid link or if Auto-Negotiation is disabled and there is a valid link.
0	Link Status	0, RO	Link Status: 1 = Valid link established (for either 10 or 100 Mb/s operation) 0 = Link not established The criteria for link validity is implementation specific.

This register implements the MII Interrupt PHY Specific Control register. Sources for interrupt generation include: Link State Change, Jabber Event, Remote Fault, Auto-Negotiation Complete or any of the counters becoming half-full. Note that the TINT bit operates independently of the INTEN bit. In other words, INTEN does not need to be active to generate the test interrupt.

Table 15. MII Interrupt PHY Specific Control Register (MIPSCR) Address 11h

Bit	Bit Name	Default	Description
15:2	Reserved	0, RO	Reserved: Writes ignored, Read as 0
1	INTEN	0, RW	Interrupt Enable: 1 = Enable event based interrupts 0 = Disable event based interrupts
0	TINT	0, RW	Test Interrupt: Forces the PHY to always generate an interrupt to allow testing of the interrupt. 1 = Generate an interrupt at the end of each access 0 = Do not generate interrupt

This register implements the MII Interrupt PHY Generic Status Register.

Table 16. MII Interrupt PHY Generic Status Register (MIPGSR) Address 12h

Bit	Bit Name	Default	Description
15	MINT	0, RO/COR	MII Interrupt Pending: Indicates that an interrupt is pending and is cleared by the current read. A read of this will also clear the MII Interrupt bit (8) of the PHYSTS (10h) register.
14:0	Reserved	0, RO	Reserved: Writes ignored, Read as 0

8.0 Register Block (Continued)

This counter provides information required to implement the isolates attribute within the Repeater Port managed object class of Clause 30 of the IEEE 802.3 specification.

Table 17. Disconnect Counter Register (DCR) Address 13h

Bit	Bit Name	Default	Description
15:0	DCNT[15:0]	<0000h>, RW / COR	Disconnect Counter: This 16 bit counter increments for each isolate event. Each time the CIM detects a transition from the False Carrier state to the Link Unstable state of the Carrier Integrity State Machine, the counter increments. This counter rolls over when it reaches its max count (FFFFh).

This counter provides information required to implement the FalseCarriers attribute within the MAU managed object class of Clause 30 of the IEEE 802.3 specification.

Table 18. False Carrier Sense Counter Register (FCSCR) Address 14h

Bit	Bit Name	Default	Description
15:0	FCSCNT[15:0]	<0000h>, RW / COR	False Carrier Event Counter: This 16 bit counter increments for each false carrier event. A false carrier event occurs when carrier sense is asserted without J/K symbol detection. This counter rolls over when it reaches its max count (FFFFh).

This counter provides information required to implement the aSymbolErrorDuringCarrier attribute within the PHY managed object class of Clause 30 of the IEEE 802.3 specification.

Table 19. Receive Error Counter Register (RECR) Address 15h

Bit	Bit Name	Default	Description
15:0	RXERCNT[15:0]	<0000h>, RW / COR	RX_ER Counter: This 16 bit counter is incremented for each receive error detected. The counter is incremented when valid carrier is present and there is at least one occurrence of an invalid data symbol. This event can increment only once per valid carrier event. If a collision is present, this attribute will not increment. This counter rolls over when it reaches its max count (FFFFh).

Table 20. 100 Mb/s PCS Configuration and Status Register (PCSR) Address 16h

Bit	Bit Name	Default	Description
15	Single_SD	0, RW	Single Ended Signal Detect Enable: 1=Single Ended SD mode enabled 0=Single Ended SD mode disabled
14	FEFI_EN	Strap, RW	Far End Fault Indication Mode: 1 = FEFI mode enabled 0 = FEFI mode disabled Note: If Auto-Negotiation is enabled, bit 12 of BMCR, this bit is RO and forced to zero. Additionally, if FX_EN is set to a one then this bit is RO and forced to a one.
13	DESCR_TO_RST	0, RW	Reset Descrambler Time-Out Counter: 1 = Reset Time-Out Counter 0 = Normal operation

8.0 Register Block (Continued)

Table 20. 100 Mb/s PCS Configuration and Status Register (PCSR) Address 16h (Continued)

Bit	Bit Name	Default	Description
12	DESCR_TO_SEL	0, RW	<p>Descrambler Time-out Select: 1 = Descrambler Timer set to 2 ms 0 = Descrambler Timer set to 722 μs</p> <p>The Descrambler Timer selects the interval over which a minimum number of IDLES are required to be received to maintain descrambler synchronization. The default time of 722 μs supports 100BASE-X compliant applications.</p> <p>A timer time-out indicates a loss of descrambler synchronization which cause the descrambler to restart its operation by immediately looking for IDLES.</p> <p>The 2 ms option allows applications with Maximum Transmission Units (packet sizes) larger than IEEE 802.3 to maintain descrambler synchronization (i.e., Token Ring/Fast-Ethernet switch/router applications).</p>
11	DESCR_TO_DIS	0, RW	<p>Descrambler Time-out Disable: 1 = Time-out Counter in the descrambler section of the receiver disabled 0 = Time-out Counter enabled</p>
10	LD_SCR_SD	0, RW	<p>Load Scrambler Seed: 1 = Load Scrambler Seed continuously 0 = Normal operation</p>
9	TX_QUIET	0, RW	<p>100 Mps Transmit True Quiet Mode: 1 = Transmit True Quiet mode 0 = Normal mode</p>
8:7	TX_PATTERN[1:0]	<00>, RW	<p>100 Mps Transmit Test Pattern: <00> = Normal operation <01> = Send FEFI pattern <10> = Send 1.28 μs period pattern (640 ns high/low time) <11> = Send 160 ns period pattern (80 ns high/low time)</p>
6	F_LINK_100	0, RW	<p>Force Good Link in 100 Mb/s: 1 = Force 100 Mb/s Good Link status 0 = Normal 100 Mb/s operation</p> <p>This bit is useful for diagnostic purposes.</p>
5	CIM_DIS	Strap, RW	<p>Carrier Integrity Monitor Disable: 1 = Carrier Integrity Monitor function disabled (Node/Switch operation) 0 = Carrier Integrity Monitor function enabled (Repeater operation)</p> <p>The THIN/REPEATER determines the default state of this bit to automatically enable or disable the CIM function as required for IEEE 802.3 compliant applications. The value latched into this bit at power-on/reset is the compliment of the value forced on the THIN/REPEATER input. After power-on/reset, software may enable or disable this function independent of repeater or node/switch mode.</p>

8.0 Register Block (Continued)

Table 20. 100 Mb/s PCS Configuration and Status Register (PCSR) Address 16h (Continued)

Bit	Bit Name	Default	Description
4	CIM_STATUS	0, RO	<p>Carrier Integrity Monitor Status:</p> <p>This bit indicates the status of the Carrier Integrity Monitor function. This status is optionally muxed out through the TX_LED pin when the LED_TXRX_MODE bits (8:7) of the PHYCTRL register (address 19h) are set to either <10> or <01>.</p> <p>1 = Unstable link condition detected 0 = Unstable link condition not detected</p>
3	CODE_ERR	0, RW	<p>Code Errors:</p> <p>1 = Forces code errors to be reported with the value 5h on RXD[3:0] and with RX_ER set to 1. 0 = Forces code errors to be reported with the value of 6h on RXD[3:0] and with RX_ER set to 1.</p>
2	PME_ERR	0, RW	<p>Premature End Errors:</p> <p>1 = Forces premature end errors to be reported with the value 4h on RXD[3:0] and with RX_ER set to 1. 0 = Forces premature end errors to be reported with the value 6h on RXD[3:0] and with RX_ER set to 1. Premature end errors are caused by the detection of two IDLE symbols in the receive data stream prior to the T/R symbol pair denoting end of stream delimiter.</p>
1	LINK_ERR	0, RW	<p>Link Errors:</p> <p>1 = Forces link errors to be reported with the value 3h on RXD[3:0] and with RX_ER set to 1. 0 = Data is passed to RXD[3:0] unchanged and with RX_ER set to 0.</p>
0	PKT_ERR	0, RW	<p>Packet Errors:</p> <p>1 = Forces packet errors (722 s time-out) to be reported with the value 2h on RXD[3:0] and with RX_ER set to 1. 0 = Data is passed to RXD[3:0] unchanged and with RX_ER set to 0.</p>

Table 21. Loopback & Bypass Register (LBR) Address 17h

Bit	Bit Name	Default	Description
15	Reserved	0, RO	Reserved: Writes ignored, read as 0.
14	BP_STRETCH	0, RW	<p>Bypass LED Stretching:</p> <p>This will bypass the LED stretching and the LEDs will reflect the internal value.</p> <p>1 = Bypass LED stretching 0 = Normal operation</p>
13	BP_4B5B	Strap, RW	<p>Bypass 4B5B Encoding and 5B4B Decoding:</p> <p>This bit is set according to the strap configuration of the SYMBOL pin at power-up/reset. After reset this bit may be written to by software.</p> <p>1 = 4B5B encoder and 5B4B decoder functions bypassed 0 = Normal 4B5B and 5B4B operation</p>

8.0 Register Block (Continued)

Table 21. Loopback & Bypass Register (LBR) Address 17h (Continued)

Bit	Bit Name	Default	Description
12	BP_SCR	Strap, RW	<p>Bypass Scrambler/Descrambler Function:</p> <p>This bit is set according to the strap configuration of the SYMBOL pin or the FXEN pin at power-up/reset. After reset this bit may be written to by software.</p> <p>1 = Scrambler and descrambler functions bypassed 0 = Normal scrambler and descrambler operation</p>
11	BP_RX	Strap, RW	<p>Bypass Receive Function:</p> <p>This bit is set according to the strap configuration of the SYMBOL pin at power-up/reset. After reset this bit may be written to by software.</p> <p>1 = Receive functions (descrambler and symbol decoding functions) bypassed. 0 = Normal operation.</p>
10	BP_TX	Strap, RW	<p>Bypass Transmit Function:</p> <p>This bit is set according to the strap configuration of the SYMBOL pin at power-up/reset. After reset this bit may be written by software.</p> <p>1 = Transmit functions (symbol encoder and scrambler) bypassed 0 = Normal operation</p>
9:7	100_DP_CTL	Strap, RW	<p>100Mps Data Path Control Bits:</p> <p>At reset, if $\overline{\text{FXEN}}$ is true then this will default to <011>, else it will default to <000>. These bits control the 100Mps loopback function in CorePhy as follows:</p> <p><000> Normal Mode <001> CorePhy Loopback <010> Reserved <011> Normal Fiber <100> Reserved <101> Reserved <110> Reserved <111> Reserved</p> <p>Note: A write to the Loopback bit (14) of the BMCR (00h) will override the value set in this register.</p>
6	RESERVED	0, RO	Reserved: Writes as 0, read as 0
5	TW_LBEN	0, RW	<p>TWISTER Loopback Enable:</p> <p>1 = TWISTER loopback 0 = Normal mode</p> <p>Note: A write to the Loopback bit (14) of the BMCR (00h) will override the value set in this register.</p>
4	10Mb_ENDEC_LB	0, RW	<p>10 Mb/s ENDEC Loopback:</p> <p>1 = 10Mb/s ENDEC loopback 0 = Normal TREX operation</p> <p>Note: A write to the Loopback bit (14) of the BMCR (00h) will override the value set in this register.</p>
3	RESERVED	0, RO	Reserved: Writes as 0, read as 0
2	RESERVED	0, RO	Reserved: Writes as 0, read as 0

8.0 Register Block (Continued)

Table 21. Loopback & Bypass Register (LBR) Address 17h (Continued)

Bit	Bit Name	Default	Description
1	RESERVED	0, RO	Reserved: Writes as 0, read as 0
0	RESERVED	0, RO	Reserved: Writes as 0, read as 0

Table 22. 10BASE-T Control & Status Register (10BTSCR) Address 18h

Bit	Bit Name	Default	Description
15:14	RESERVED	0, RO	Reserved: Writes ignored, read as 0
13	AUI_TPI	0, RO	TREX Operating Mode: This bit shows the current operating mode of TREX as chosen by the Auto-Switch function. 1 = AUI mode 0 = TPI mode
12	RX_SERIAL	Strap, RW	10BASE-T RX Serial Mode: This bit is set according to the strap configuration of the SERIAL10 pin at power-up/reset. After reset this bit may be written to by software. 1 = 10BASE-T rx Serial mode selected 0 = 10BASE-T rx Nibble mode selected Serial mode is not supported for 100 Mb/s operation.
11	TX_SERIAL	Strap, RW	10BASE-T TX Serial Mode: This bit is set according to the strap configuration of the SERIAL_10 pin at power-up/reset. After reset this bit may be written to by software. 1 = 10BASE-T tx Serial mode selected 0 = 10BASE-T tx Nibble mode selected Serial mode is not supported for 100 Mb/s operation.
10	POL_DS	0, RW	Polarity Detection & Correction Disable: 1 = Polarity Sense & Correction disabled 0 = Polarity Sense & Correction enabled
9	AUTOSW_EN	0, RW	AUI/TPI Autoswitch: 1 = Enable autoswitch 0 = Disable autoswitch function The use of autoswitch should be strictly limited to applications that do not support Auto-Negotiation. Do not enable Auto-Negotiation when enabling autoswitch as this may result in improper operation.
8	LP_DS	0, RW	Link Pulse Disable: 1 = Reception of link pulses ignored, good link condition forced 0 = Good link not forced, link pulses observed for good link
7	HB_DS	0, RW	Heartbeat Disable: 1 = Heartbeat function disabled 0 = Heartbeat function enabled When the device is configured for full duplex operation, this bit will be ignored (the collision/heartbeat function has no meaning in Full Duplex mode). HB_DS will read back as 1 if in Full Duplex mode or Repeater mode.

8.0 Register Block (Continued)

Table 22. 10BASE-T Control & Status Register (10BTSCR) Address 18h (Continued)

Bit	Bit Name	Default	Description
6	LS_SEL	0, RW	Low Squelch Select: Selects between standard 10BASE-T receiver squelch threshold and a reduced squelch threshold that is useful for longer cable applications. 1 = Low Squelch Threshold selected 0 = Normal 10BASE-T Squelch Threshold selected
5	AUI_SEL	0, RW	AUI Select: 1 = Select AUI interface 0 = Select TPI interface
4	JAB_DS	0, RW	Jabber Disable: Enables or disables the Jabber function when the device is in 10BASE-T Full Duplex or 10BASE-T TREX Loopback mode (TRES_LBEN bit 4 in the LBR, address 17h). 1 = Jabber function disabled 0 = Jabber function enabled
3	THIN_SEL	0, RW	Thin Ethernet Select: 1 = Asserts THIN pin (pin 63) 0 = Deasserts THIN pin (pin 63) This pin may be used as a general purpose select pin.
2	RX_FILT_DS	0, RW	TPI Receive Filter Disable: 1 = Disable TPI receive filter 0 = Enable TPI receive filter
1	RESERVED	0, RO	Reserved: Writes ignored, read as 0
0	RESERVED	0, RO	Reserved: Writes as 0, read as 0

Table 23. PHY Control Register (PHYCTRL) Address 19h

Bit	Bit Name	Default	Description
15	RESERVED	0, RO	Reserved: Writes ignored, read as 0
14	RESERVED	0, RO	Reserved: Writes ignored, read as 0
13:12	TW_EQSEL[1:0]	<00>, RW	TWISTER Equalization Select: Used in combination to select the 4 equalization modes. Modes 3, 2, 1 should be accessible to external device pin for debug purposes. <11> = Equalization off <10> = Equalization on <01> = Adaptive Equalization <00> = Full Adaptive Equalization
11	TW_BLW_DS	0, RW	TWISTER Base Line Wander Disable: 1 = BLW Feedback loop disabled 0 = BLW Feedback loop enabled
10	RESERVED	0, RO	Reserved: Writes ignored, read as 0

8.0 Register Block (Continued)

Table 23. PHY Control Register (PHYCTRL) Address 19h (Continued)

Bit	Bit Name	Default	Description
9	REPEATER	Strap, RW	<p>Repeater/Node Mode:</p> <p>1 = Repeater mode 0 = Node mode</p> <p>In repeater mode the Carrier Sense (CRS) output from the device is asserted due to receive activity only. In Node mode, and not configured for full duplex operation, CRS is asserted due to either receive or transmit activity. In 100 Mb/s operation the CIM monitor is disabled. In Repeater mode HB_DS is enabled (bit 7 register 10BTSCR(18h))</p> <p>This bit is set according to the strap configuration of the REPEATER pin at power-up/reset.</p>
8:7	LED_TXRX_MODE	<00>, RW	<p>LED_TX/RX Mode Select:</p> <p><11> = LED_RX indicates both RX and TX activity and LED_TX indicates interrupt. Interrupt signal is active high. <10> = LED_RX indicates both RX and TX activity and LED_TX indicates Carrier Integrity Monitor status. Interrupt signal is active high. <01> = LED_RX indicates RX activity only and LED_TX indicates Carrier Integrity Monitor status. <00> = Normal LED_TX and LED_RX operation.</p> <p>Note: Using LED_TX to indicate Carrier Integrity Monitor status is useful for network management purposes in 100BASE-TX mode. This mode only works if the PHY_Address_2 is strapped low because the PHYTER does not properly implement the Activity LED function if LED_RX/PHYAD[2] is strapped high.</p>
6	LED_DUP_MODE	0, RW	<p>LED_DUP Mode Select:</p> <p>1 = LED_FDPOLE configured to indicate polarity reversal in 10BASE-T mode, and full duplex in 100BASE-TX mode 0 = LED_FDPOLE configured to indicate full duplex in all operating modes.</p>
5	FX_EN	Strap, RW	<p>Fiber Mode Enable:</p> <p>This bit is set by the $\overline{\text{FX_EN}}$ at power-on/reset or by software after reset. If this bit is set then the signals FEFI_EN and BP_SCR are driven internally. When this bit is set, fiber mode enabled, Auto-Negotiation must be disabled.</p> <p>1 = Fiber Mode enabled 0 = Fiber Mode disabled</p>
4:0	PHYADDR[4:0]	(STRAP), RW	<p>PHY Address:</p> <p>The values of the PHYAD[4:0] pins are latched to this register at power-up/reset. The first PHY address bit transmitted or received is the MSB of the address (bit 4). A station management entity connected to multiple PHY entities must know the appropriate address of each PHY. A PHY address of <00000> that is latched in to the part at power up/reset will cause the Isolate bit of the BMCR (bit 10, register address 00h) to be set.</p> <p>After power up/reset the only way to enable or disable isolate mode is to set or clear the Isolate bit (bit 10) of BMCR (address 00). After power up/reset writing <00000> to bits [4:0] of this register will not cause the part to enter isolate mode.</p>

9.0 Electrical Specifications

Absolute Maximum Ratings

Supply Voltage (V_{CC})	-0.5 V to 7.0 V
Input Voltage (DC_{IN})	-0.5 V to $V_{CC} + 0.5$ V
Output Voltage (DC_{OUT})	-0.5 V to $V_{CC} + 0.5$ V
Storage Temperature	-65°C to 150°C
ECL Signal Output Current	-50mA
ESD Protection	2000 V

Recommended Operating Conditions

	Min	Typ	Max	Units
Supply voltage (V_{DD})	4.75	5.0	5.25	V
Ambient Temperature (T_A)	0		70	°C
X1 Input Frequency Stability (over temperature)	-50		+50	PPM
X1 Input Duty Cycle	35		65	%
Center Frequency (X_{FC})		25		MHz

All preliminary electrical specifications are based on IEEE 802.3u requirements and internal design considerations. These specifications will not become final until complete verification of the DP83843.

Thermal Characteristics*

	Max	Units
Maximum Case Temperature	96	°C
Maximum Die Temperature	104.7	°C
Theta Junction to Case (T_{jC})	1.1	°C / W
Theta Junction to Ambient (T_{jA}) degrees Celsius/Watt - No Airflow @ 1.0W	42.7	°C / W
Theta Junction to Ambient (T_{jA}) degrees Celsius/Watt - 225 LFPM Airflow @ 1.0W	35.3	°C / W
Theta Junction to Ambient (T_{jA}) degrees Celsius/Watt - 500 LFPM Airflow @ 1.0W	30.4	°C / W
Theta Junction to Ambient (T_{jA}) degrees Celsius/Watt - 900 LFPM Airflow @ 1.0W	26.9	°C / W

*Valid for Phytors with data code 9812 or later, for earlier data codes please contact your National Sales Representative for data.

9.0 Electrical Specifications (Continued)

9.1 DC Electrical Specification

Symbol	Pin Types	Parameter	Conditions	Min	Typ	Max	Units
V _{IH}	I I/O I/O, Z	Input High Voltage		2.0			V
	AN0 and AN1			V _{CC} - 1.0		V	
	X1			V _{CC} - 1.0		V	
V _{IL}	I I/O I/O, Z	Input Low Voltage				0.8	V
	AN0 and AN1					1.0	V
	X1					1.0	V
V _{IM}	AN0 and AN1	Input Mid Level Voltage	Pin Unconnected	(V _{CC} /2) -0.5	(V _{CC} /2)	(V _{CC} /2) +0.5	V
I _{IH}	I I/O I/O, Z	Input High Current	V _{IN} = V _{CC}			10	μA
	X1		X2 = N.C.			-100	μA
I _{IL}	I I/O I/O, Z	Input Low Current	V _{IN} = GND			10	μA
	X1		X2 = N.C.			100	μA
V _{OL}	O, Z I/O I/O, Z	Output Low Voltage	I _{OL} = 4 mA			0.4	V
V _{OH}	O, Z I/O I/O, Z	Output High Voltage	I _{OL} = -4 mA	V _{CC} - 0.5			V
V _{OL}	LED SPEED10	Output Low Voltage	I _{OL} = 2.5 mA			0.4	V
V _{OH}	LED SPEED10	Output High Voltage	I _{OL} = -2.5 mA	V _{CC} - 0.5			V
I _{OZ1}	I/O, Z O, Z	TRI-STATE Leakage	V _{OUT} = V _{CC}			10	μA
I _{OZ2}	I/O, Z O, Z	TRI-STATE Leakage	V _{OUT} = GND			-10	μA
R _{INdiff}	TPRD+/-	Differential Input Resistance	see Test Conditions section	5	6		kΩ
V _{TPTD_100}	TPTD+/-	100M Transmit Voltage	see Test Conditions section	.95	1	1.05	V
V _{TPTDsym}	TPTD+/-	100M Transmit Voltage Symmetry	see Test Conditions section	-2		+2	%
V _{TPTD_10}	TPTD+/-	10M Transmit Voltage	see Test Conditions section	2.2	2.5	2.8	V
C _{IN1}	I	CMOS Input Capacitance			8		pF
C _{IN2}	I	PECL Input Capacitance			10		pF

9.0 Electrical Specifications (Continued)

Symbol	Pin Types	Parameter	Conditions	Min	Typ	Max	Units
C _{OUT1}	O Z	CMOS Output Capacitance			8		pF
C _{OUT2}	O Z	PECL Output Capacitance			10		pF
SD _{THon}	TPRD+/-	100BASE-TX Signal detect turn-on thresh				1000	mV diff pk-pk
SD _{THoff}	TPRD+/-	100BASE-TX Signal detect turn-off thresh		200			mV diff pk-pk
V _{TH1}	TPRD+/-	10BASE-T Receive Threshold		300		585	mV
V _{TH2}	TPRD+/-	10BASE-T Receive Low Squelch Threshold		150		300	mV
V _{DIFF}	FXSD+/-, FXRD+/-	PECL Input Voltage Differential	see Test Conditions section	300			mV
V _{CM}	FXSD+/-, FXRD+/-	PECL Common Mode Voltage	see Test Conditions section	V _{CC} - 2.0		V _{CC} - 0.5	mV
I _{INECL}	FXSD+/-, FXRD+/-	PECL Input Current	V _{IN} = V _{OLmax} or V _{OHmax}	-300		300	μA
V _{OHECL}	FXTD+/-	PECL Output High Voltage	V _{IN} = V _{IHmax}	V _{CC} - 1.125		V _{CC} - 0.78	V
V _{OLECL}	FXTD+/-	PECL Output Low Voltage	V _{IN} = V _{ILmax}	V _{CC} - 1.86		V _{CC} - 1.515	V
V _{ODaui}	AUITD+/-	Differential Output Voltage	see Test Conditions section	± 550		± 1200	mV
V _{OBaui}	AUITD+/-	Differential Idle Output Voltage Imbalance	see Test Conditions section		40		mV
V _{DSaui}	AUIRD+/-, AUICD+/-	Differential Squelch Threshold	see Test Conditions section		± 160	± 300	mV
I _{dd100}	Supply	100BASE-TX (Full Duplex)	see Test Conditions section		135	150	mA
I _{dd10}	Supply	10BASE-TX (Full Duplex)	see Test Conditions section		100	110	mA
I _{ddFX}	Supply	100BASE-FX (Full Duplex)	see Test Conditions section		100	115	mA
I _{ddAN}	Supply	Auto-Negotiation	see Test Conditions section		100	120	mA
I _{ddPD}	Supply	Power Down	see Test Conditions section		25	30	mA

9.0 Electrical Specifications (Continued)

9.2 CGM Clock Timing

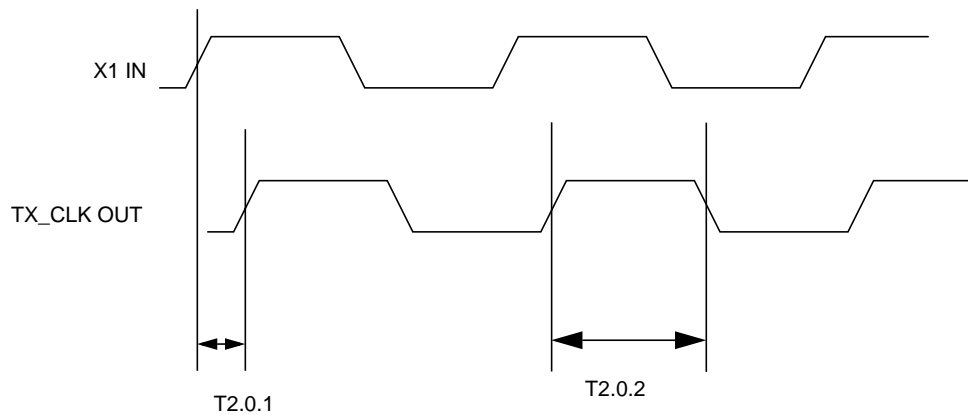

Parameter	Description	Notes	Min	Typ	Max	Units
T2.0.1	X1 to TX_CLK Delay		-3		+3	ns
T2.0.2	TX_CLK Duty Cycle		35		65	%

9.3 MII Serial Management AC Timing

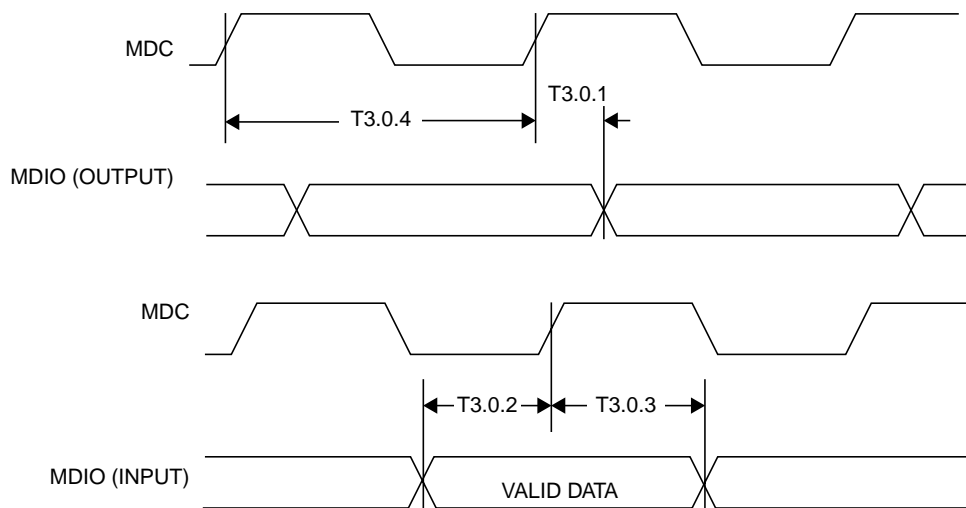

Parameter	Description	Notes	Min	Typ	Max	Units
T3.0.1	MDC to MDIO (Output) Delay Time		0		300	ns
T3.0.2	MDIO (Input) to MDC Setup Time		10			ns
T3.0.3	MDIO (Input) to MDC Hold Time		10			ns
T3.0.4	MDC Frequency				2.5	MHz

9.0 Electrical Specifications (Continued)

9.4 100 Mb/s AC Timing

9.4.1 100 Mb/s MII Transmit Timing

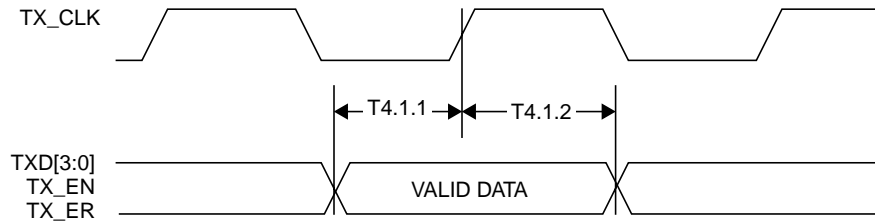

Parameter	Description	Notes	Min	Typ	Max	Units
T4.1.1	TXD[3:0], TX_EN, TX_ER Data Setup to TX_CLK	100 Mb/s Normal mode	14			ns
	TXD[4:0] Data Setup to TX_CLK	100 Mb/s Symbol mode	10			ns
T4.1.2	TXD[3:0], TX_EN, TX_ER Data Hold from TX_CLK	100 Mb/s Normal mode	-1			ns
	TXD[4:0] Data Hold from TX_CLK	100 Mb/s Symbol mode	-1			ns

9.4.2 100 Mb/s MII Receive Timing

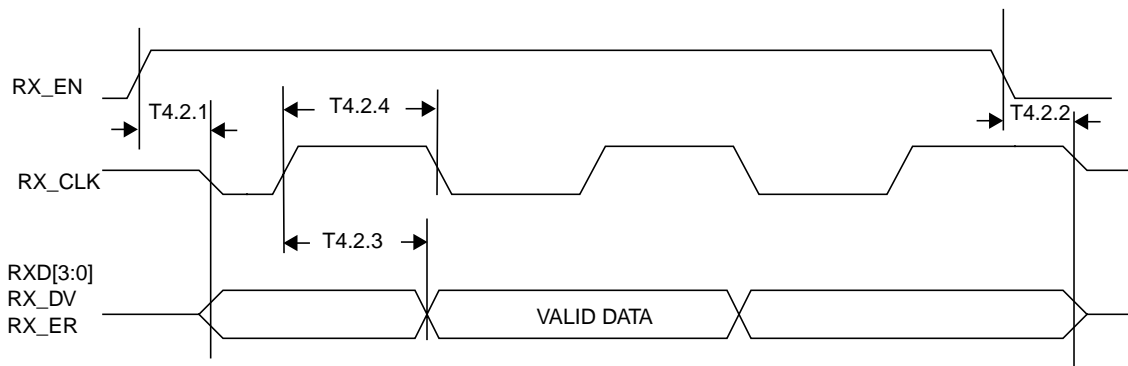

Parameter	Description	Notes	Min	Typ	Max	Units
T4.2.1	RX_EN to RX_CLK, RXD[3:0], RX_ER, RX_DV Active	All 100 Mb/s modes			15	ns
T4.2.2	RX_EN to RX_CLK, RXD[3:0], RX_ER, RX_DV TRI-STATE	All 100 Mb/s modes			25	ns
T4.2.3	RX_CLK to RXD[3:0], RX_DV, RX_ER Delay	100 Mb/s Normal mode	10		30	ns
	RX_CLK to RXD[4:0], Delay	100 Mb/s Symbol mode	10		30	ns
T4.2.4	RX_CLK Duty Cycle	All 100 Mb/s modes	35		65	%

9.0 Electrical Specifications (Continued)

9.4.3 100BASE-TX Transmit Packet Latency Timing

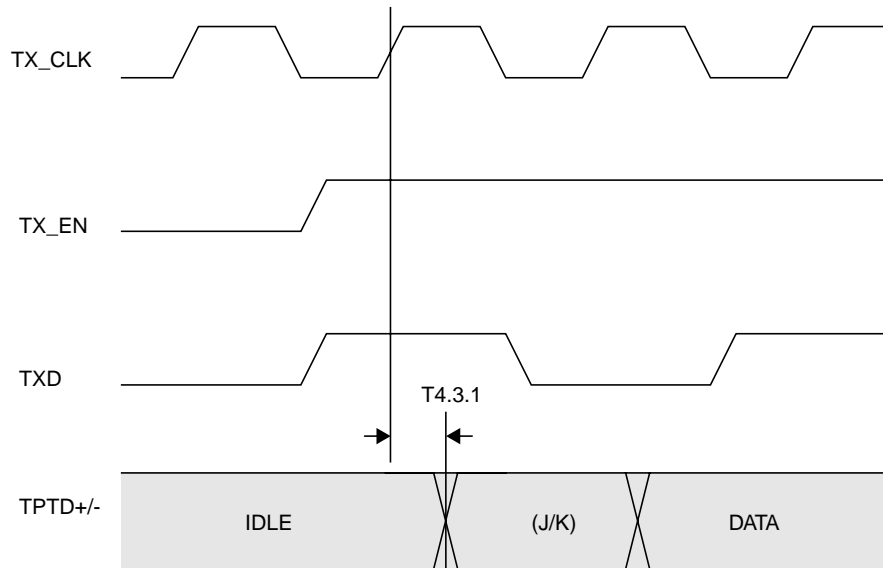

Parameter	Description	Notes	Min	Typ	Max	Units
T4.3.1	TX_CLK to TPTD+/- Latency	100 Mb/s Normal mode			6.0	bits
		100 Mb/s Symbol mode			6.0	bits

Note: For Normal mode, latency is determined by measuring the time from the first rising edge of TX_CLK occurring after the assertion of TX_EN to the first bit of the “j” code group as output from the TPTD± pins. 1 bit time = 10ns in 100 Mb/s mode. For Symbol mode, because TX_EN has no meaning, latency is measured from the first rising edge of TX_CLK occurring after the assertion of a data nibble on the Transmit MII to the first bit (MSB) of that nibble as output from the TPTD± pins. 1 bit time = 10 ns in 100 Mb/s mode.

9.0 Electrical Specifications (Continued)

9.4.4 100BASE-TX Transmit Packet Deassertion Timing

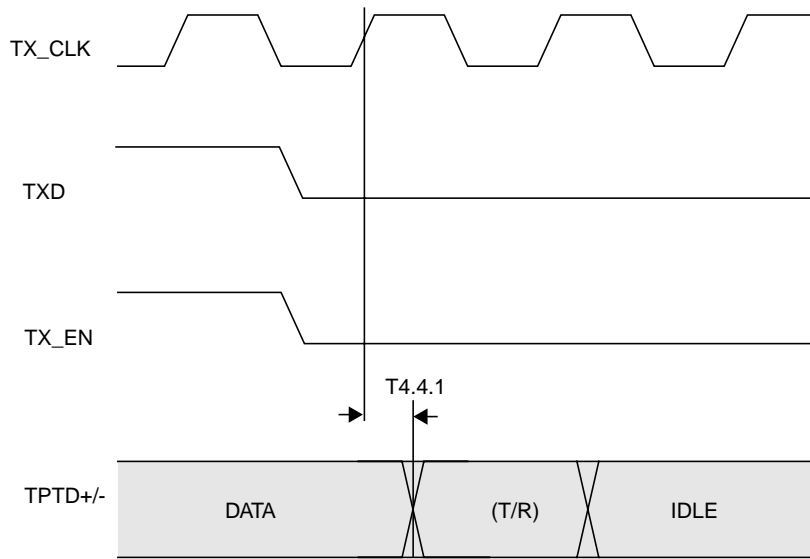

Parameter	Description	Notes	Min	Typ	Max	Units
T4.4.1	TX_CLK to TPTD+/- Deassertion	100 Mb/s Normal mode			6.0	bits
		100 Mb/s Symbol mode			6.0	bits

Note: Deassertion is determined by measuring the time from the first rising edge of TX_CLK occurring after the deassertion of TX_EN to the first bit of the "T" code group as output from the TPTD± pins. For Symbol mode, because TX_EN has no meaning, Deassertion is measured from the first rising edge of TX_CLK occurring after the deassertion of a data nibble on the Transmit MII to the last bit (LSB) of that nibble when it deasserts on the wire. 1 bit time = 10 ns in 100 Mb/s mode.

9.0 Electrical Specifications (Continued)

9.4.5 100BASE-TX Transmit Timing

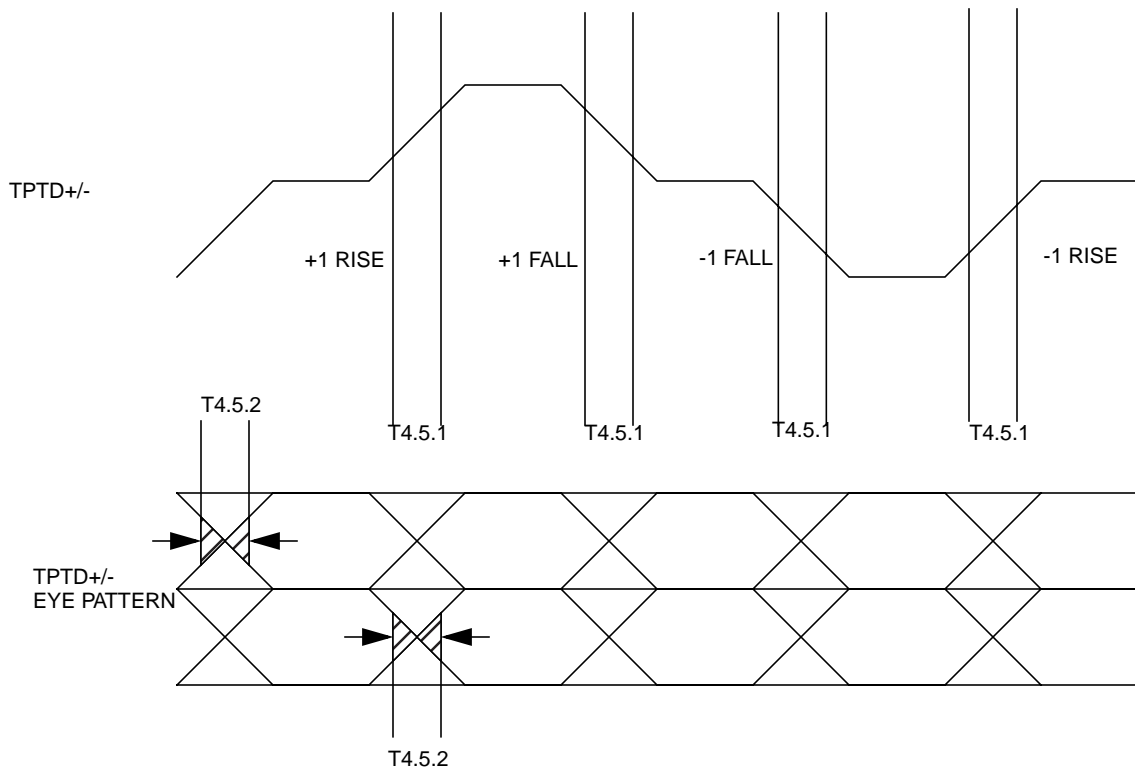

Parameter	Description	Notes	Min	Typ	Max	Units
T4.5.1	100 Mb/s TPTD+/- Rise and Fall Times	see Test Conditions section	3	4	5	ns
	100 Mb/s Rise/Fall Mismatch				500	ps
T4.5.2	100 Mb/s TPTD+/- Transmit Jitter				1.4	ns

Note: Normal Mismatch is the difference between the maximum and minimum of all rise and fall times.

Note: Rise and fall times taken at 10% and 90% of the +1 or -1 amplitude.

9.0 Electrical Specifications (Continued)

9.4.6 100BASE-TX Receive Packet Latency Timing

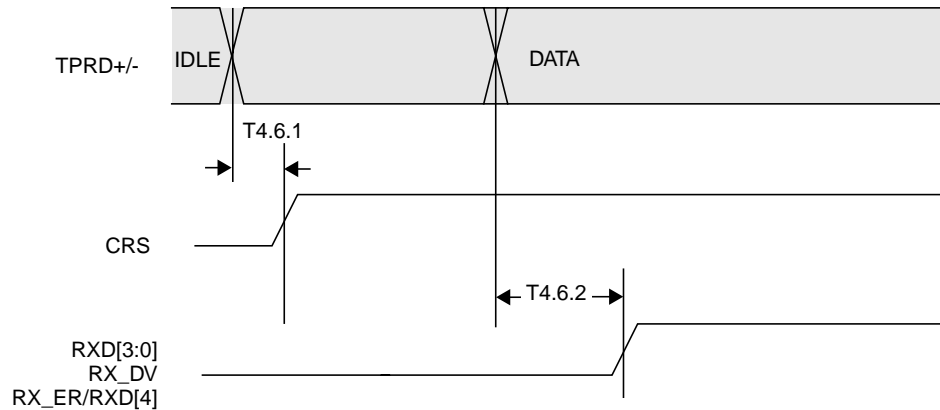

Parameter	Description	Notes	Min	Typ	Max	Units
T4.6.1	Carrier Sense on Delay	100 Mb/s Normal mode			17.5	bits
T4.6.2	Receive Data Latency	100 Mb/s Normal mode			21	bits
		100 Mb/s Symbol mode			12	bits

Note: Carrier Sense On Delay is determined by measuring the time from the first bit of the "J" code group to the assertion of Carrier Sense.

Note: 1 bit time = 10 ns in 100 Mb/s mode.

Note: TPRD± voltage amplitude is greater than the Signal Detect Turn-On Threshold Value.

9.4.7 100BASE-TX Receive Packet Deassertion Timing

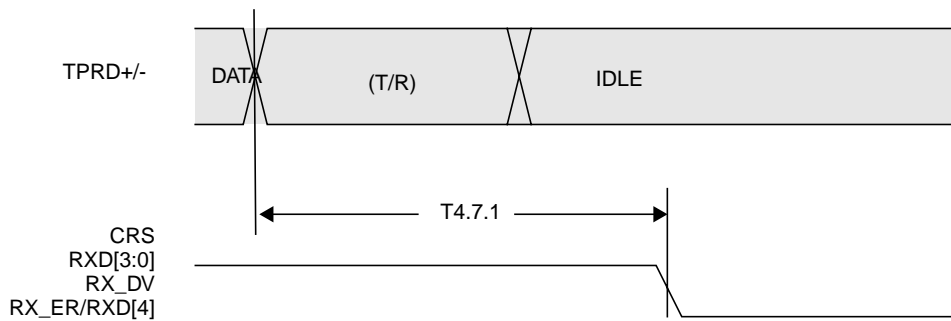

Parameter	Description	Notes	Min	Typ	Max	Units
T4.7.1	Carrier Sense Off Delay	100 Mb/s Normal mode			21.5	bits

Note: Carrier Sense Off Delay is determined by measuring the time from the first bit of the "T" code group to the deassertion of Carrier Sense.

Note: 1 bit time = 10 ns in 100 Mb/s mode.

9.0 Electrical Specifications (Continued)

9.4.8 100BASE-FX Transmit Packet Latency Timing

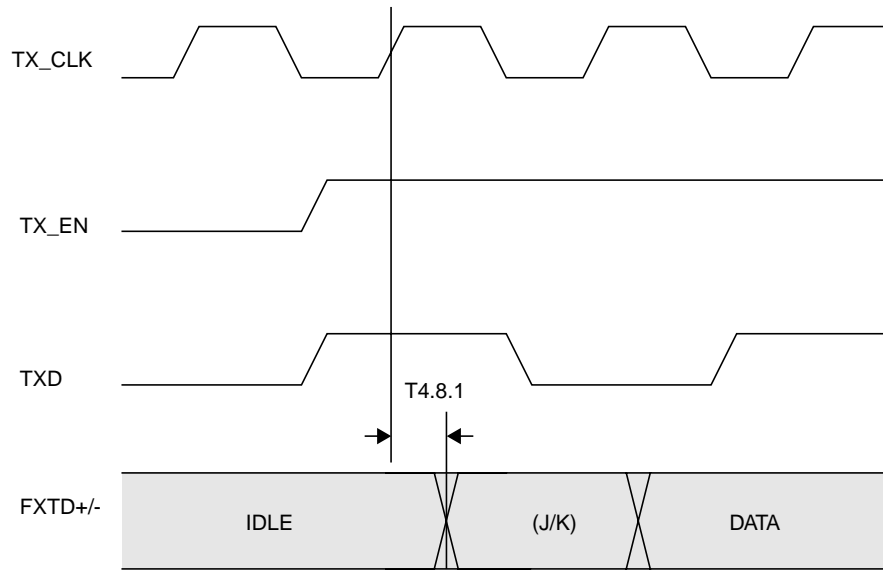

Parameter	Description	Notes	Min	Typ	Max	Units
T4.8.1	TX_CLK to FXTD+/- Latency	100 Mb/s Normal mode			4.0	bits
		100 Mb/s Symbol mode			4.0	bits

Note: For Normal mode, Latency is determined by measuring the time from the first rising edge of TX_CLK occurring after the assertion of TX_EN to the first bit of the "j" code group as output from the FXTD± pins. For Symbol mode, because TX_EN has no meaning, Latency is measured from the first rising edge of TX_CLK occurring after the assertion of a data nibble on the Transmit MII to the first bit (MSB) of that nibble when it first appears at the FXTD± outputs.

9.0 Electrical Specifications (Continued)

9.4.9 100BASE-FX Transmit Packet Deassertion Timing

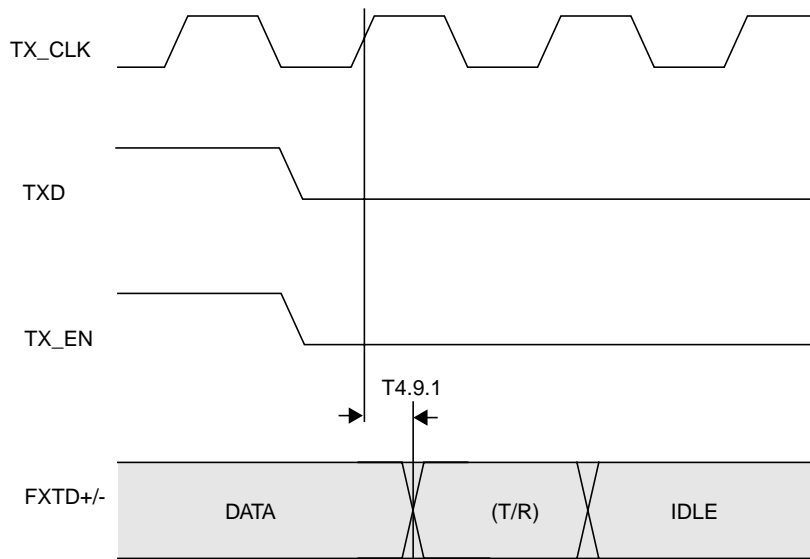

Parameter	Description	Notes	Min	Typ	Max	Units
T4.9.1	TX_CLK to FXTD+/- Deassertion	100 Mb/s Normal mode			4.0	bits
		100 Mb/s Symbol mode			4.0	bits

Note: Deassertion is determined by measuring the time from the first rising edge of TX_CLK occurring after the deassertion of TX_EN to the first bit of the "T" code group as output from the FXTD± pins. For Symbol mode, because TX_EN has no meaning, Deassertion is measured from the first rising edge of TX_CLK occurring after the deassertion of a data nibble on the Transmit MII to the last bit (LSB) of that nibble when it deasserts as output from the FXTD± pins. 1 bit time = 10 ns in 100 Mb/s mode.

9.4.10 100BASE-FX Receive Packet Latency Timing

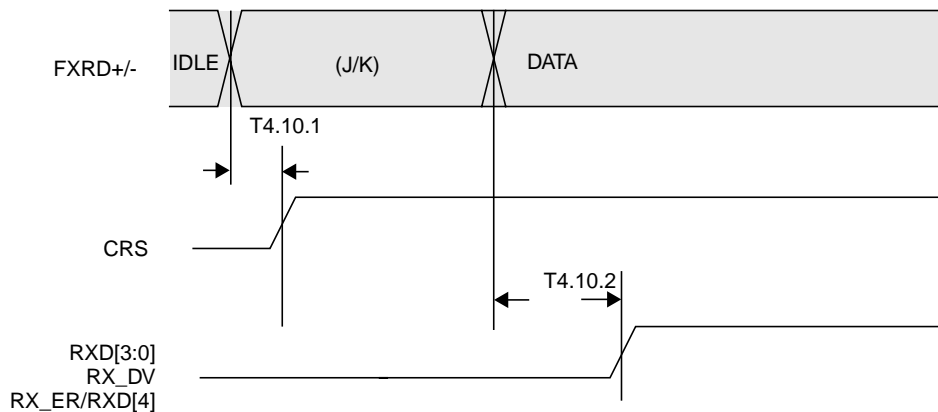

Parameter	Description	Notes	Min	Typ	Max	Units
T4.10.1	Carrier Sense On Delay	100 Mb/s Normal mode			17.5	bits
T4.10.2	Receive Data Latency	100 Mb/s Normal mode			19	bits
		100 Mb/s Symbol mode			19	bits

Note: Carrier Sense On Delay is determined by measuring the time from the first bit of the "J" code group to the assertion of Carrier Sense.

Note: 1 bit time = 10 ns in 100 Mb/s mode.

9.0 Electrical Specifications (Continued)

9.4.11 100BASE-FX Receive Packet Deassertion Timing

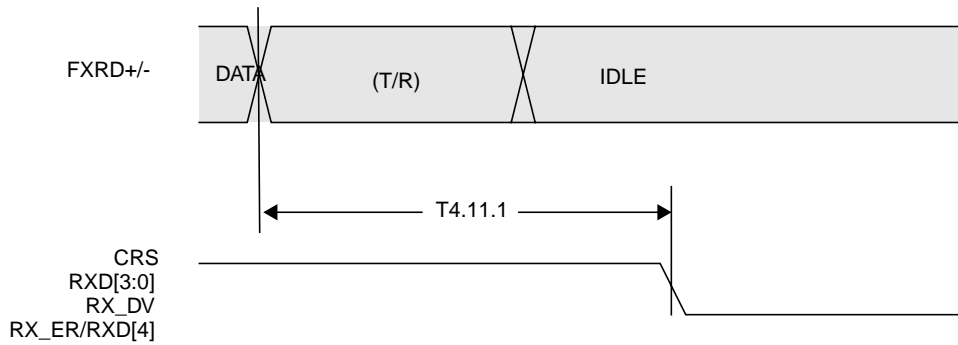

Parameter	Description	Notes	Min	Typ	Max	Units
T4.11.1	Carrier Sense Off Delay	100 Mb/s Normal mode			21.5	bits

Note: Carrier Sense Off Delay is determined by measuring the time from the first bit of the "T" code group to the deassertion of Carrier Sense.

Note: 1 bit time = 10 ns in 100 Mb/s mode.

9.5 10 Mb/s AC Timing

9.5.12 10 Mb/s MII Transmit Timing

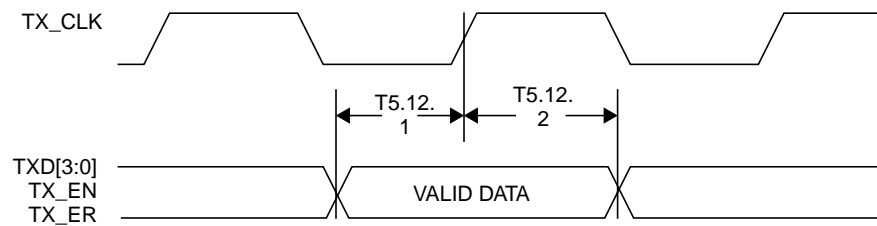

Parameter	Description	Notes	Min	Typ	Max	Units
T5.12.1	TXD[3:0], TX_EN Data Setup to TX_CLK	10 Mb/s Nibble mode	25			ns
	TXD0 Data Setup to TX_CLK	10 Mb/s Serial mode	25			ns
T5.12.2	TXD[3:0], TX_EN Data Hold from TX_CLK	10 Mb/s Nibble mode	-1			ns
	TXD0 Data Hold from TX_CLK	10 Mb/s Serial mode	-1			ns

9.0 Electrical Specifications (Continued)

9.5.13 10 Mb/s MII Receive Timing

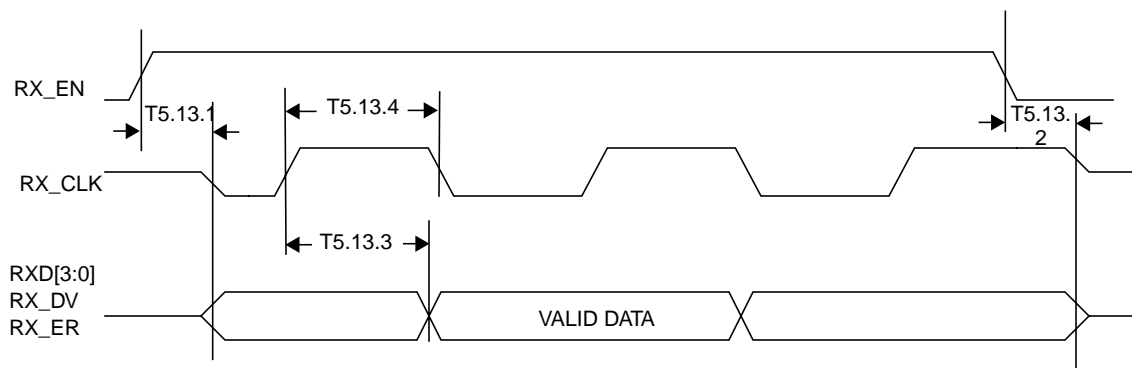

Parameter	Description	Notes	Min	Typ	Max	Units
T5.13.1	RX_EN to RX_CLK, RXD[3:0], RX_DV Active	All 10 Mb/s modes			10	ns
T5.13.2	RX_EN to RX_CLK, RXD[3:0], RX_DV TRI-STATE	All 10 Mb/s modes			25	ns
T5.13.3	RX_CLK to RXD[3:0], RX_DV, RX_ER Delay	10 Mb/s Nibble mode	190		210	ns
	RX_CLK to RXD[3:0], RX_DV, RX_ER Delay	10 Mb/s Serial mode	40		60	ns
T5.13.4	RX_CLK Duty Cycle	All 10 Mb/s modes	35		65	%

9.5.14 10BASE-T Transmit Timing (Start of Packet)

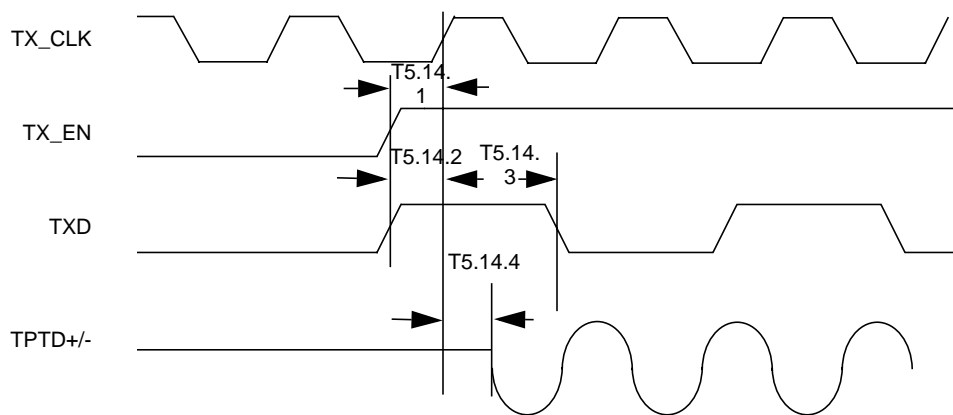

Parameter	Description	Notes	Min	Typ	Max	Units
T5.14.1	Transmit Enable Setup Time from the Rising Edge of TX_CLK	10 Mb/s Nibble mode	25			ns
		10 Mb/s Serial mode	25			ns
T5.14.2	Transmit Data Setup Time from the Rising Edge of TX_CLK	10 Mb/s Nibble mode	25			ns
		10 Mb/s Serial mode	25			ns
T5.14.3	Transmit Data Hold Time from the Rising Edge of TX_CLK	10 Mb/s Nibble mode	-1			ns
		10 Mb/s Serial mode	-1			ns
T5.14.4	Transmit Output Delay from the Rising Edge of TX_CLK	10 Mb/s Nibble mode			6.8	bits
		10 Mb/s Serial mode			2.5	bits

Note: 1 bit time = 100 ns in 10 Mb/s mode for both nibble and serial operation.

9.0 Electrical Specifications (Continued)

9.5.15 10BASE-T Transmit Timing (End of Packet)

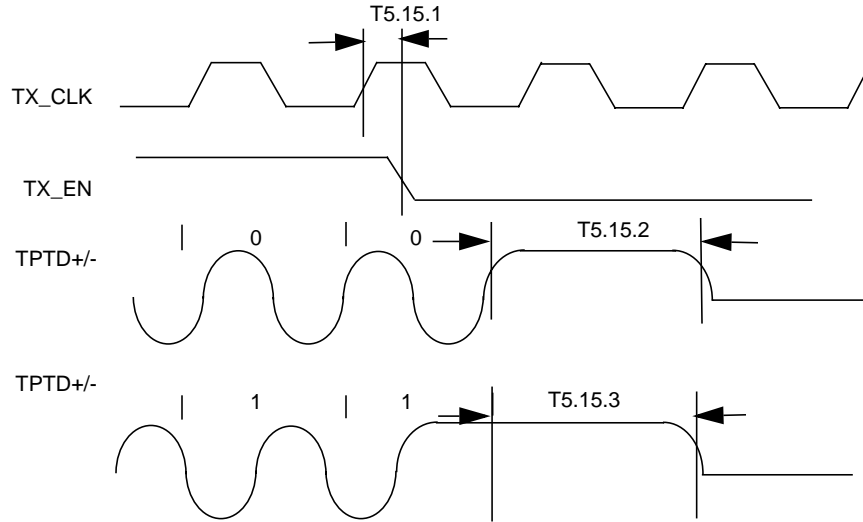

Parameter	Description	Notes	Min	Typ	Max	Units
T5.15.1	Transmit Enable Hold Time from the Rising Edge of TX_CLK	10 Mb/s Nibble mode	-1			ns
		10 Mb/s Serial mode	-1			ns
T5.15.2	End of Packet High Time (with '0' ending bit)	10 Mb/s Nibble mode	250			ns
		10 Mb/s Serial mode	250			ns
T5.15.3	End of Packet High Time (with '1' ending bit)	10 Mb/s Nibble mode	250			ns
		10 Mb/s Serial mode	250			ns

9.0 Electrical Specifications (Continued)

9.5.16 10BASE-T Receive Timing (Start of Packet)

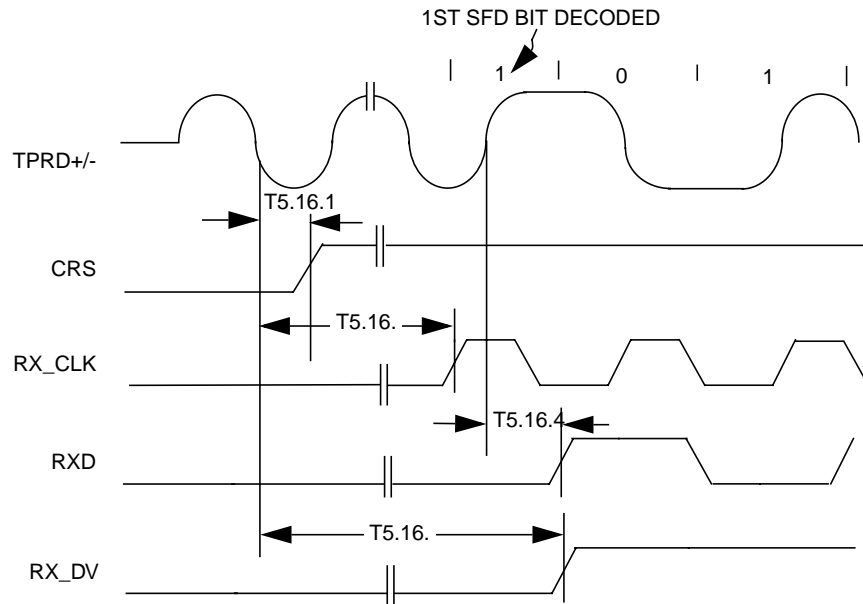

Parameter	Description	Notes	Min	Typ	Max	Units
T5.16.1	Carrier Sense Turn On Delay (TPRD+/- to CRS)	10 Mb/s Nibble mode			1	μ s
		10 Mb/s Serial mode			1	μ s
T5.16.2	Decoder Acquisition Time	10 Mb/s Nibble mode			3.6	μ s
		10 Mb/s Serial mode			3.2	μ s
T5.16.3	Receive Data Latency	10 Mb/s Nibble mode			17.3	bits
		10 Mb/s Serial mode			10	bits
T5.16.4	SFD Propagation Delay	10 Mb/s Nibble mode			10	bits
		10 Mb/s Serial mode			4.5	bits

Note: 10BASE-T receive Data Latency is measured from first bit of preamble on the wire to the assertion of RX_DV.

Note: 1 bit time = 100 ns in 10 Mb/s mode for both nibble and serial operation.

9.5.17 10BASE-T Receive Timing (End of Packet)

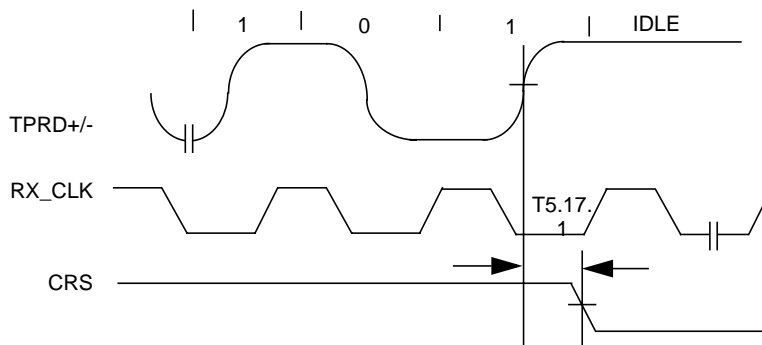

Parameter	Description	Notes	Min	Typ	Max	Units
T5.17.1	Carrier Sense Turn Off Delay	10 Mb/s Nibble mode			1.1	us
		10 Mb/s Serial mode			450	ns

9.0 Electrical Specifications (Continued)

9.5.18 10 Mb/s AUI Timing

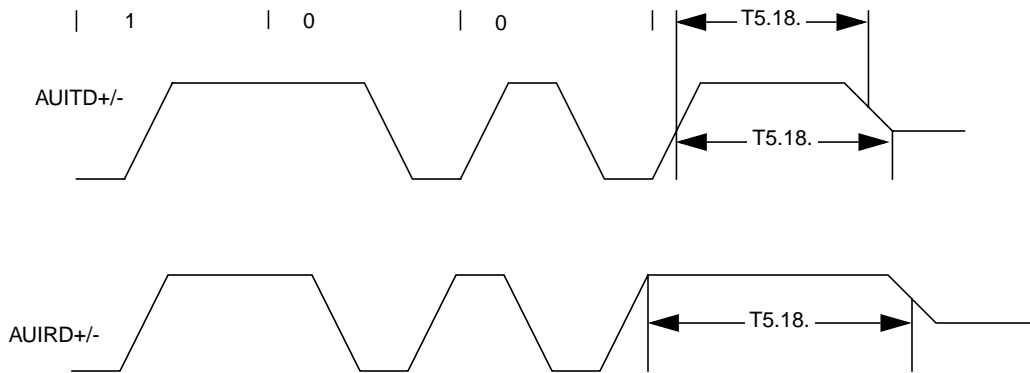

Parameter	Description	Notes	Min	Typ	Max	Units
T5.18.1	AUI Transmit Output High Before Idle		200			ns
T5.18.2	AUI Transmit Output Idle Time				8000	ns
T5.18.3	AUI Receive End of Packet Hold Time		225			ns

Note: The worst case for T5.18.1 is data ending in a '0'.

9.5.19 10 Mb/s Heartbeat Timing

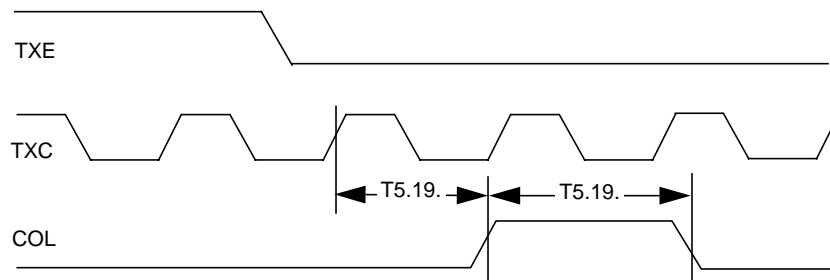

Parameter	Description	Notes	Min	Typ	Max	Units
T5.19.1	CD Heartbeat Delay	10 Mb/s Nibble mode		700		ns
		10 Mb/s Serial mode		700		ns
T5.19.2	CD Heartbeat Duration	10 Mb/s Nibble mode		700		ns
		10 Mb/s Serial mode		700		ns

9.0 Electrical Specifications (Continued)

9.5.20 10 Mb/s Jabber Timing

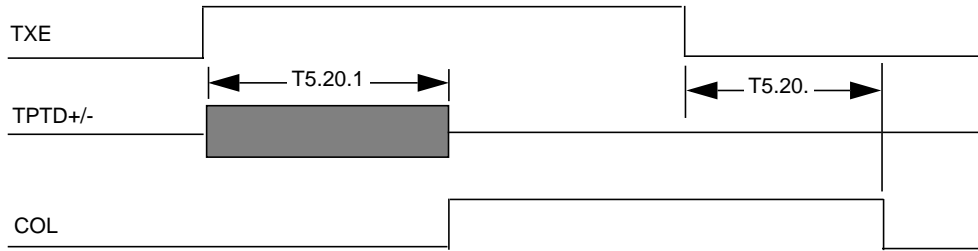

Parameter	Description	Notes	Min	Typ	Max	Units
T5.20.1	Jabber Activation Time	10 Mb/s Nibble mode		26		ms
		10 Mb/s Serial mode		26		ms
T5.20.2	Jabber Deactivation Time	10 Mb/s Nibble mode		500		ms
		10 Mb/s Serial mode		500		ms

9.5.21 10BASE-T Normal Link Pulse Timing

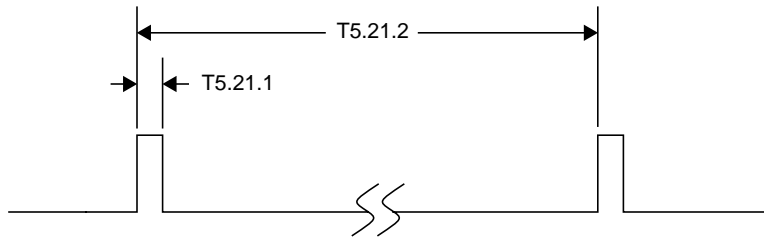

Parameter	Description	Notes	Min	Typ	Max	Units
T5.21.1	Pulse Width			100		ns
T5.21.2	Pulse Period		8	16	24	ms

Note: These specifications represent both transmit and receive timings.

9.0 Electrical Specifications (Continued)

9.6 Auto-Negotiation Fast Link Pulse (FLP) Timing

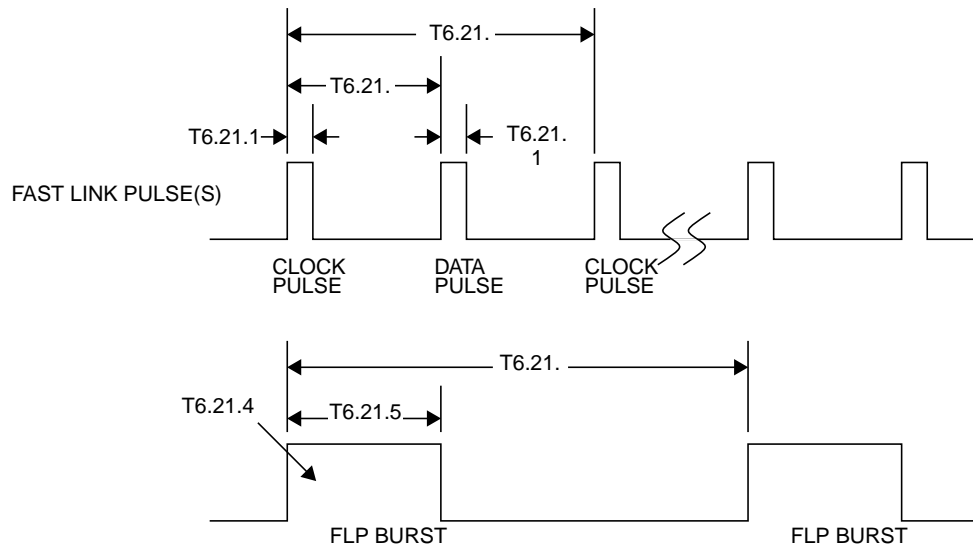

Parameter	Description	Notes	Min	Typ	Max	Units
T6.21.1	Clock, Data Pulse Width			100		ns
T6.21.2	Clock Pulse to Clock Pulse Period		111	125	139	μ s
T6.21.3	Clock Pulse to Data Pulse Period	Data = 1	55.5		69.5	μ s
T6.21.4	Number of Pulses in a Burst		17		33	#
T6.21.5	Burst Width			2		ms
T6.21.6	FLP Burst to FLP Burst Period		8		24	ms

Note: These specifications represent both transmit and receive timings.

9.7 100BASE-X Clock Recovery Module (CRM) Timing

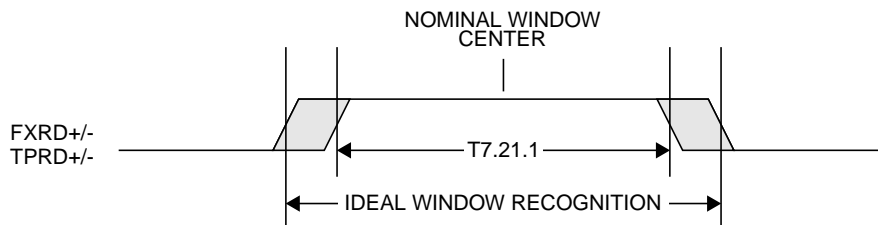

Parameter	Description	Notes	Min	Typ	Max	Units
T7.21.1	CRM Window Recognition Region		-2.7		2.7	ns

Note: The Ideal window recognition region is ± 4 ns.

9.0 Electrical Specifications (Continued)

9.7.22 100BASE-X CRM Acquisition Time

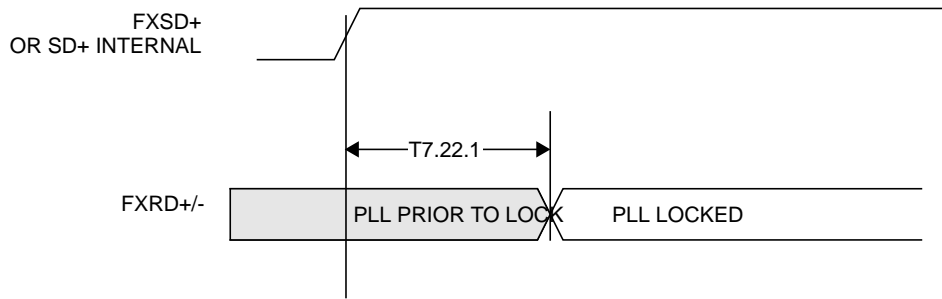

Parameter	Description	Notes	Min	Typ	Max	Units
T7.22.1	CRM Acquisition	100 Mb/s			250	μ s

Note: The Clock Generation Module (CGM) must be stable for at least 100 μ s before the Clock Recovery Module (CRM) can lock to receive data.

Note: SD+ internal comes from the internal Signal Detect function block when in 100BASE-TX mode.

9.7.23 100BASE-TX Signal Detect Timing

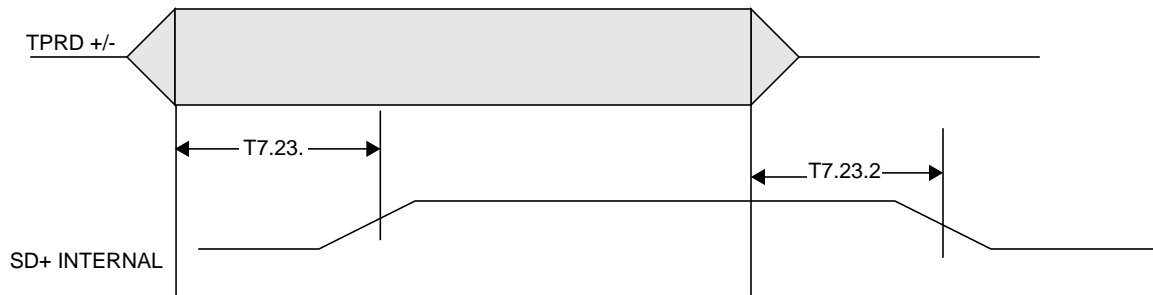

Parameter	Description	Notes	Min	Typ	Max	Units
T7.23.1	SD Internal Turn-on Time				1	ms
T7.23.2	SD Internal Turn-off Time				300	μ s

Note: The SD internal signal is available as an external signal in Symbol mode.

Note: The signal amplitude at TPRD +/- is TP-PMD compliant.

9.0 Electrical Specifications (Continued)

9.8 Reset Timing

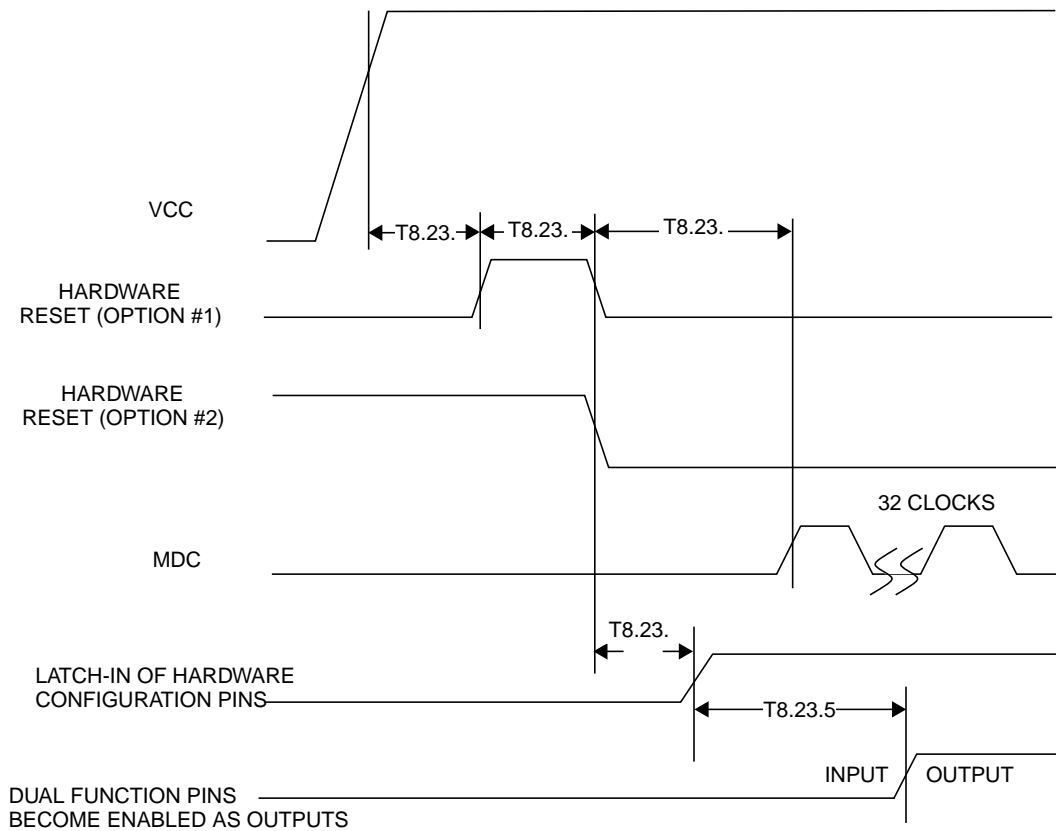

Parameter	Description	Notes	Min	Typ	Max	Units
T8.23.1	Internal Reset Time		500			μs
T8.23.2	Hardware RESET Pulse Width		1			μs
T8.23.3	Post Reset Stabilization time prior to MDC preamble for register accesses	MDIO is pulled high for 32 bit serial management initialization	500			μs
T8.23.4	Hardware Configuration Latch-in Time from the Deassertion of Reset (either soft or hard)	Hardware Configuration Pins are described in the Pin Description section		800		ns
T8.23.5	Hardware Configuration pins transition to output drivers	It is important to choose pull-up and/or pull-down resistors for each of the hardware configuration pins that provide fast RC time constants in order to latch-in the proper value prior to the pin transitioning to an output driver		800		ns

Note: Software Reset should be initiated no sooner than 500 μs after power-up or the deassertion of hardware reset.

Note: It is important to choose pull-up and/or pull-down resistors for each of the hardware configuration pins that provide fast RC time constants in order to latch-in the proper value prior to the pin transitioning to an output driver.

Note: The timing for Hardware Reset Option 2 is equal to parameter T1 plus parameter T2 (501 μs total).

9.0 Electrical Specifications (Continued)

9.9 Loopback Timing

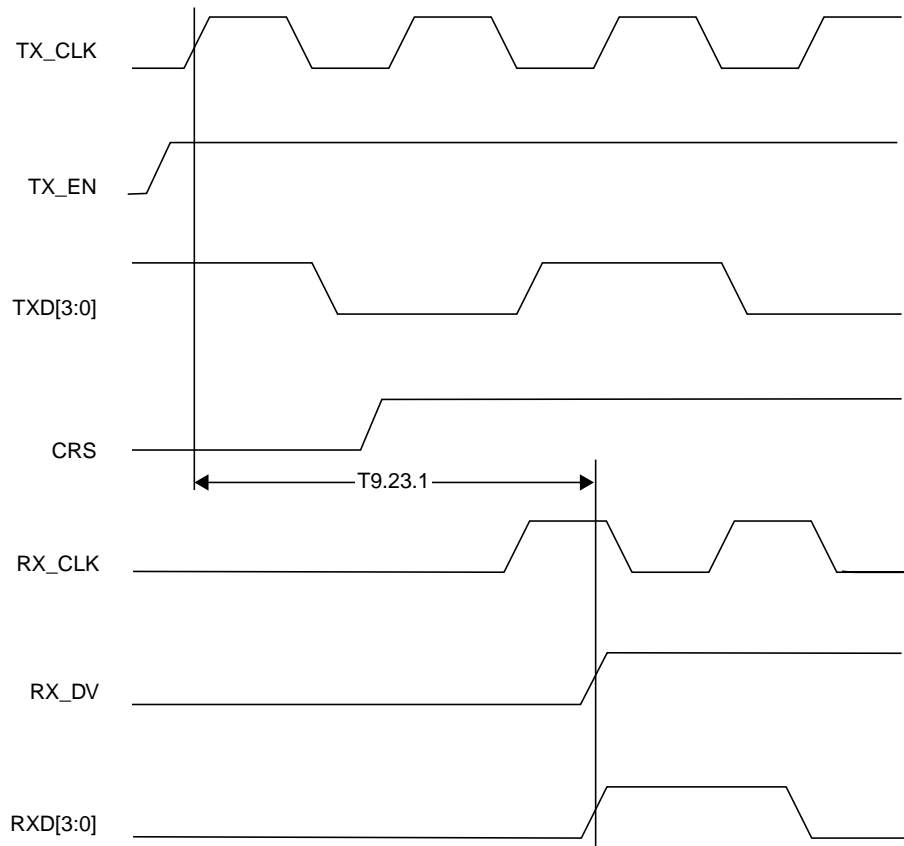

Parameter	Description	Notes	Min	Typ	Max	Units
T9.23.1	TX_EN to RX_DV Loopback	100 Mb/s			240	ns
		10 Mb/s Serial mode			650	ns
		10 Mb/s Nibble mode			2	μs

Note: Due to the nature of the descrambler function, all 100BASE-X Loopback modes will cause an initial "dead-time" of up to 550 μs during which time no data will be present at the receive MII outputs. The 100BASE-X timing specified is based on device delays after the initial 550μs "dead-time".

Note: During loopback (all modes) both the TPTD± or FXTD/AUITD± outputs remain inactive by default.

9.0 Electrical Specifications (Continued)

9.10 Isolation Timing

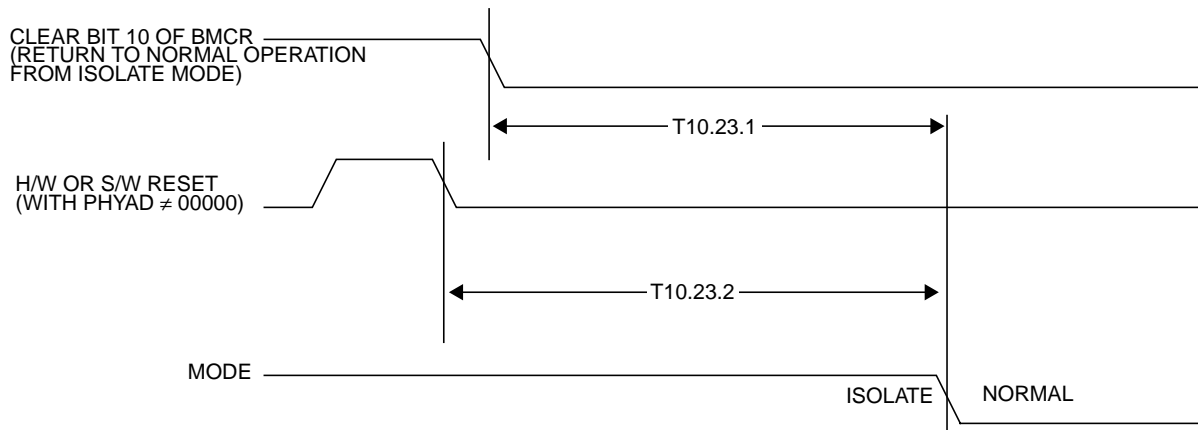

Parameter	Description	Notes	Min	Typ	Max	Units
T10.23.1	From software clear of bit 10 in the BMCR register to the transition from Isolate to Normal Mode				100	μs
T10.23.2	From Deassertion of S/W or H/W Reset to transition from Isolate to Normal mode				500	μs

10.0 Test Conditions

This section contains information relating to the specific test environments, including stimulus and loading parameters, for the DP83843. These test conditions are categorized in the following subsections by each type of pin/interface including:

- FXTD/AUITD+/- Outputs sourcing AUI
- FXTD/AUITD+/- Outputs sourcing 100BASE-FX
- CMOS Outputs i.e. MII and LEDs
- TPTD+/- Outputs sourcing 100BASE-TX
- TPTD+/- Outputs sourcing 10BASE-T

Additionally, testing conditions for I_{dd} measurements are included.

10.1 FXTD/AUITD+/- Outputs (sourcing AUI levels)

When configured for AUI operation, these differential outputs source Manchester encoded 10 Mb/s data at AUI logic levels. These outputs are loaded as illustrated in Figure 26.

10.2 FXTD/AUITD+/- Outputs (sourcing PECL)

When configured for 100BASE-FX operation, these differential outputs source unscrambled 125 Mb/s data at PECL logic levels. These outputs are loaded as illustrated in Figure 27.

10.3 CMOS Outputs (MII and LED)

Each of the MII and LED outputs are loaded with a controlled current source to either ground or V_{CC} for testing V_{oh} , V_{ol} , and AC parametrics. The associated capacitance

of this load is 50 pF. The diagram in Figure 28 illustrates the test configuration.

It should be noted that the current source and sink limits are set to 4.0 mA when testing/loading the MII output pins. The current source and sink limits are set to 2.5 mA when testing/loading the LED output pins.

10.4 TPTD+/- Outputs (sourcing 10BASE-T)

When configured for 10BASE-T operation, these differential outputs source Manchester encoded binary data at 10BASE-T logic levels. These outputs are loaded as illustrated in Figure 29. Note that the transmit amplitude measurements are made across the secondary of the transmit transformer as specified by the IEEE 802.3 specification.

10.5 TPTD+/- Outputs (sourcing 100BASE-TX)

When configured for 100BASE-TX operation, these differential outputs source scrambled 125Mb/s data at MLT-3 logic levels. These outputs are loaded as illustrated in Figure 29. Note that the transmit amplitude and rise/fall time measurements are made across the secondary of the transmit transformer as specified by the IEEE 802.3u specification.

10.6 I_{dd} Measurement Conditions

The DP83843 PHYTER is currently tested for total device I_{dd} under four operational modes:

- 100BASE-TX Full Duplex (max packet length / min IPG)
- 10BASE-TX Half Duplex (max packet length / min IPG)
- 100BASE-FX Full Duplex (max packet length / min IPG)

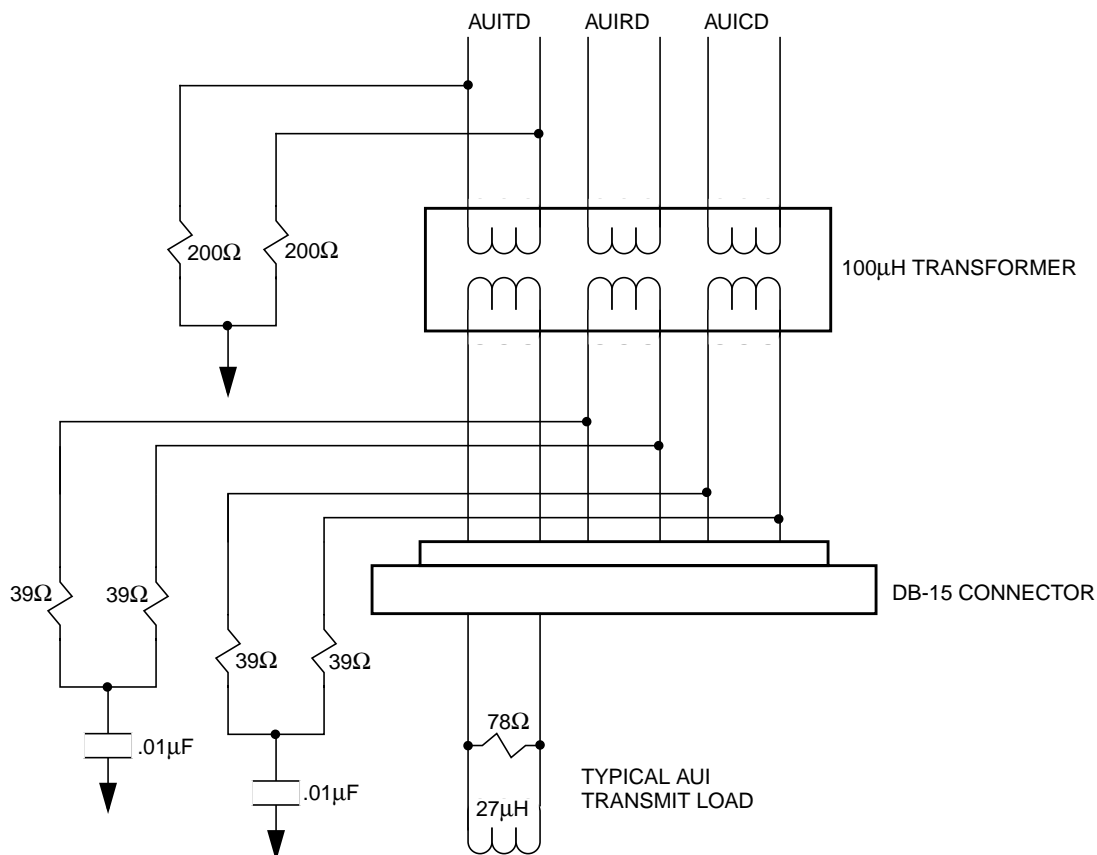

Figure 26. AUI Test Load

10.0 Test Conditions (Continued)

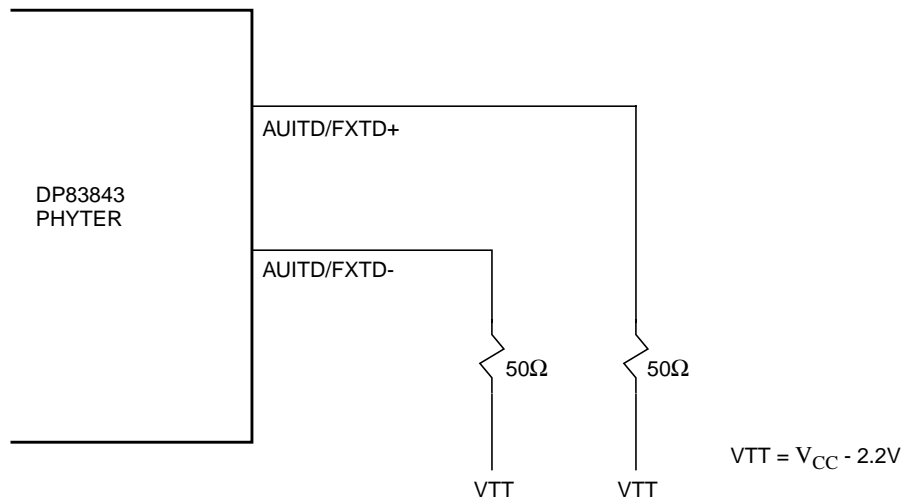

Figure 27. 100BASE-FX Test Load

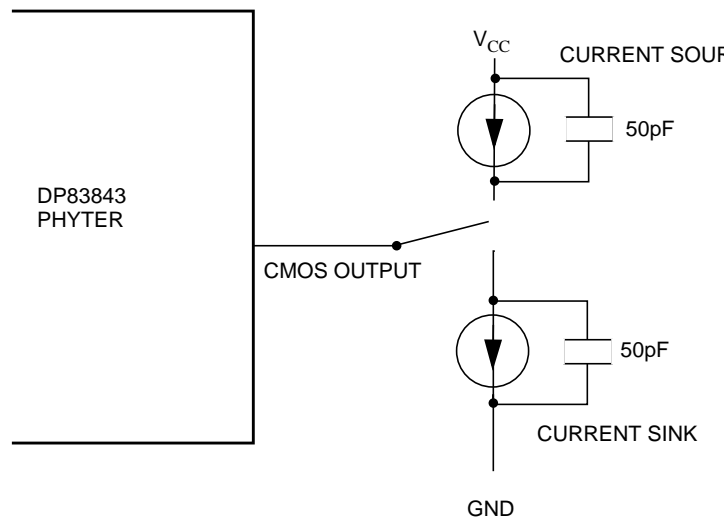

Figure 28. CMOS Output Test Load

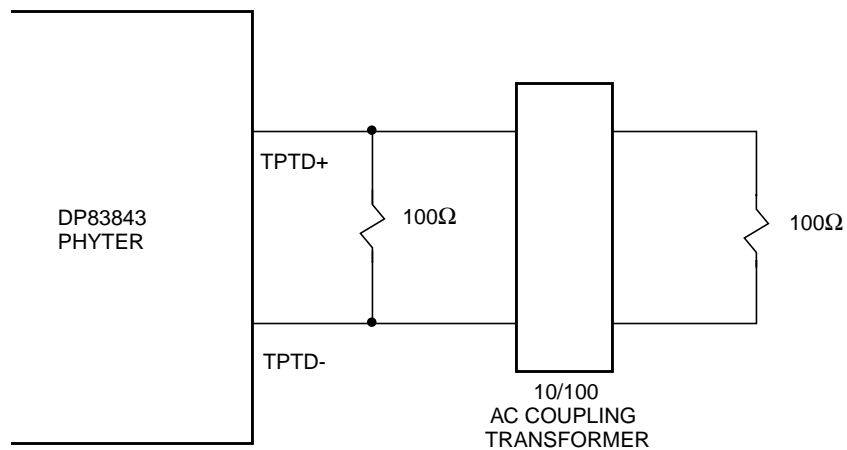

Figure 29. 10/100 Twisted Pair Load (zero meters)

IMPORTANT NOTICE

Texas Instruments Incorporated and its subsidiaries (TI) reserve the right to make corrections, enhancements, improvements and other changes to its semiconductor products and services per JESD46, latest issue, and to discontinue any product or service per JESD48, latest issue. Buyers should obtain the latest relevant information before placing orders and should verify that such information is current and complete. All semiconductor products (also referred to herein as "components") are sold subject to TI's terms and conditions of sale supplied at the time of order acknowledgment.

TI warrants performance of its components to the specifications applicable at the time of sale, in accordance with the warranty in TI's terms and conditions of sale of semiconductor products. Testing and other quality control techniques are used to the extent TI deems necessary to support this warranty. Except where mandated by applicable law, testing of all parameters of each component is not necessarily performed.

TI assumes no liability for applications assistance or the design of Buyers' products. Buyers are responsible for their products and applications using TI components. To minimize the risks associated with Buyers' products and applications, Buyers should provide adequate design and operating safeguards.

TI does not warrant or represent that any license, either express or implied, is granted under any patent right, copyright, mask work right, or other intellectual property right relating to any combination, machine, or process in which TI components or services are used. Information published by TI regarding third-party products or services does not constitute a license to use such products or services or a warranty or endorsement thereof. Use of such information may require a license from a third party under the patents or other intellectual property of the third party, or a license from TI under the patents or other intellectual property of TI.

Reproduction of significant portions of TI information in TI data books or data sheets is permissible only if reproduction is without alteration and is accompanied by all associated warranties, conditions, limitations, and notices. TI is not responsible or liable for such altered documentation. Information of third parties may be subject to additional restrictions.

Resale of TI components or services with statements different from or beyond the parameters stated by TI for that component or service voids all express and any implied warranties for the associated TI component or service and is an unfair and deceptive business practice. TI is not responsible or liable for any such statements.

Buyer acknowledges and agrees that it is solely responsible for compliance with all legal, regulatory and safety-related requirements concerning its products, and any use of TI components in its applications, notwithstanding any applications-related information or support that may be provided by TI. Buyer represents and agrees that it has all the necessary expertise to create and implement safeguards which anticipate dangerous consequences of failures, monitor failures and their consequences, lessen the likelihood of failures that might cause harm and take appropriate remedial actions. Buyer will fully indemnify TI and its representatives against any damages arising out of the use of any TI components in safety-critical applications.

In some cases, TI components may be promoted specifically to facilitate safety-related applications. With such components, TI's goal is to help enable customers to design and create their own end-product solutions that meet applicable functional safety standards and requirements. Nonetheless, such components are subject to these terms.

No TI components are authorized for use in FDA Class III (or similar life-critical medical equipment) unless authorized officers of the parties have executed a special agreement specifically governing such use.

Only those TI components which TI has specifically designated as military grade or "enhanced plastic" are designed and intended for use in military/aerospace applications or environments. Buyer acknowledges and agrees that any military or aerospace use of TI components which have **not** been so designated is solely at the Buyer's risk, and that Buyer is solely responsible for compliance with all legal and regulatory requirements in connection with such use.

TI has specifically designated certain components as meeting ISO/TS16949 requirements, mainly for automotive use. In any case of use of non-designated products, TI will not be responsible for any failure to meet ISO/TS16949.

Products

Audio	www.ti.com/audio
Amplifiers	amplifier.ti.com
Data Converters	dataconverter.ti.com
DLP® Products	www.dlp.com
DSP	dsp.ti.com
Clocks and Timers	www.ti.com/clocks
Interface	interface.ti.com
Logic	logic.ti.com
Power Mgmt	power.ti.com
Microcontrollers	microcontroller.ti.com
RFID	www.ti-rfid.com
OMAP Applications Processors	www.ti.com/omap
Wireless Connectivity	www.ti.com/wirelessconnectivity

Applications

Automotive and Transportation	www.ti.com/automotive
Communications and Telecom	www.ti.com/communications
Computers and Peripherals	www.ti.com/computers
Consumer Electronics	www.ti.com/consumer-apps
Energy and Lighting	www.ti.com/energy
Industrial	www.ti.com/industrial
Medical	www.ti.com/medical
Security	www.ti.com/security
Space, Avionics and Defense	www.ti.com/space-avionics-defense
Video and Imaging	www.ti.com/video

TI E2E Community

e2e.ti.com