

■ GENERAL DESCRIPTION

MYRGC075060W31RA and MYRGC075060B31RA

are small (3.0mm×3.0mm, h=1.7mm) 36V, 600mA step-down DC/DC converter with an integrated control IC and coil. Integrating the coil makes for easier circuit board layout and minimizes malfunction and noise from the component and wiring layout.

The input voltage range is 3.0 to 36V, the switching frequency is 1.2MHz, and a synchronous rectification circuit is used to achieve a stable power supply at high efficiency.

MYRGC075060W31RA fixes the operation frequency using PWM control to suppress output ripple voltage.

MYRGC075060B31RA automatically switches between PWM and PFM control to reduce loss by lowering the operation frequency during low loads to achieve high efficiency across the entire range from low to high loads.

A 0.75V standard voltage supply is built in, and the output voltage can be set to 1.0V to 5.0V using an external resistance.

The soft start time is internally set to 2.0ms, and a time that is longer than the internal soft-start can be freely set depending on the resistance and capacity connected to the EN/SS pin.

An overcurrent protection function and thermal shutdown function are built in as protective functions to ensure safe use in the event of a short circuit.

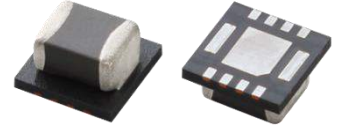

■ APPLICATIONS

- Electricity Meters
- Gas Detectors
- Various Sensors
- Industrial Equipment
- Home Appliances

■ FEATURES

Input Voltage Range	:	3.0V ~ 36V (Absolute Max 40V)
Output Voltage Range	:	1.0V ~ 5.0V
FB Voltage	:	0.75V ± 1.5%
Output Current	:	600mA
Oscillation Frequency	:	1.2MHz
Efficiency	:	86%(V _{IN} =12V, V _{OUT} =5V, I _{OUT} =300mA)
Control Methods	:	PWM control (MYRGC075060W31RA) : PWM/PFM Auto (MYRGC075060B31RA)
Function	:	Soft-start External settings Power good
Protection Circuits	:	Over Current Protection (Automatic recovery) Thermal Shutdown
Output Capacitor	:	Ceramic Capacitor
Operating Ambient Temperature	:	-40°C ~ +105°C
Environmentally Friendly	:	EU RoHS Compliant, Pb Free Halogen Free

■ TYPICAL APPLICATION CIRCUIT

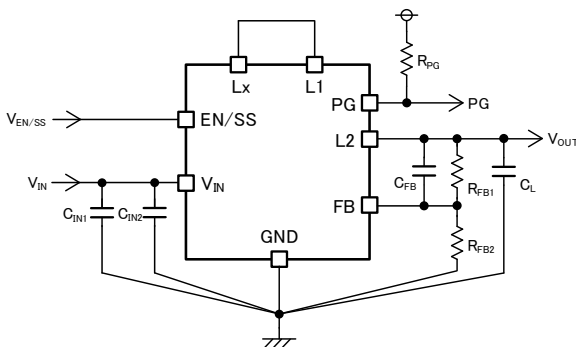

■ TYPICAL PERFORMANCE CHARACTERISTICS

MYRGC075060W31RA / MYRGC075060B31RA

V_{IN}=V_{EN/SS}=12V, V_{OUT}=5.0V

C_{IN1}=4.7μF, C_{IN2}=0.1μF, C_L=22μF

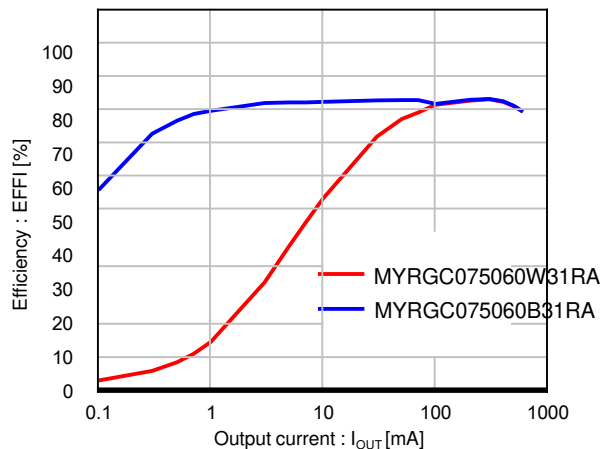

■ BLOCK DIAGRAM

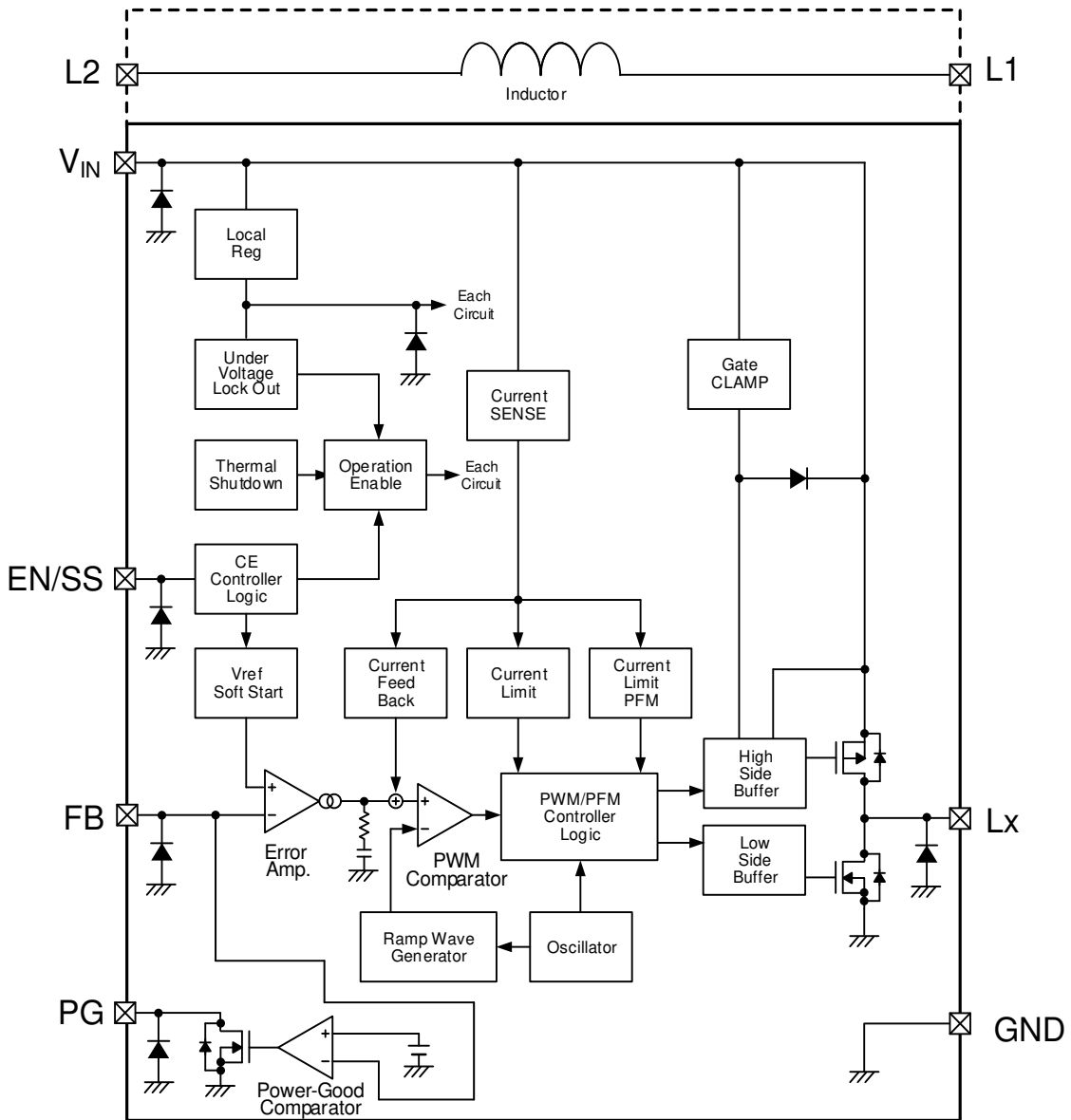

* "PWM/PFM Controller Logic" in the MYRGC075060W31RA is fixed to PWM control.
 "PWM/PFM Controller Logic" in the MYRGC075060B31RA is fixed to PWM/PFM automatic switching control.
 Diodes inside the circuit are an ESD protection diode and a parasitic diode.

■ PIN CONFIGURATION

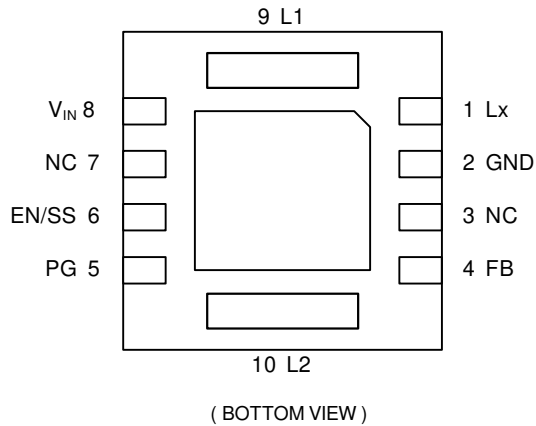

* The dissipation pad for the package should be solder plated in recommended mount pattern and metal masking so as to enhance mounting strength and heat release. If the pad needs to be connected to other pins, it should be connected to the GND (No.2) pin.

■ PIN ASSIGNMENT

PIN NUMBER	PIN NAME	FUNCTION
1	LX	Switching Output
2	GND	Ground
3	NC	No Connection
4	FB	Output Voltage Sense
5	PG	Power good Output
6	EN/SS	Enable Soft-start
7	NC	No Connection
8	V _{IN}	Power Input
9	L1	Inductor Electrodes
10	L2	Inductor Electrodes

* The NC terminals (pin numbers 3 & 7) are not connected to the IC chip.

PIN NAME	SIGNAL	STATUS
EN/SS	H	Active
	L	Stand-by
	OPEN	Undefined State ^(*)

^(*) Please do not leave the EN/SS pin open. Each should have a certain voltage

PIN NAME	CONDITION	SIGNAL
PG	$V_{FB} > V_{PGDET}$	H (High impedance)
	$V_{FB} \leq V_{PGDET}$	L (Low impedance)
	Thermal Shutdown	L (Low impedance)
	UVLO ($V_{IN} < V_{UVLOD}$)	Undefined State
	EN/SS = L	Stand-by

■ ABSOLUTE MAXIMUM RATINGS

PARAMETER	SYMBOL	RATINGS	UNITS
V_{IN} Pin Voltage	V_{IN}	-0.3 ~ +40	V
EN/SS Pin Voltage	$V_{EN/SS}$	-0.3 ~ +40	V
FB Pin Voltage	V_{FB}	-0.3 ~ +6.2	V
PG Pin Voltage	V_{PG}	-0.3 ~ +6.2	V
PG Pin Current	I_{PG}	8	mA
Lx Pin Voltage	V_{Lx}	-0.3 ~ $V_{IN}+0.3$ or +40 ^(*)	V
Power Dissipation ($T_a=25^\circ\text{C}$)	P_d	1950 (JESD51-7 board) ^(*)	mW
Operating Ambient Temperature	T_{opr}	-40 ~ +105	$^\circ\text{C}$
Storage Temperature	T_{stg}	-55 ~ +125	$^\circ\text{C}$

All voltages are described based on the GND pin.

^(*) The maximum value should be either $V_{IN}+0.3\text{V}$, or 40V, whichever is the lowest.

^(*) The power dissipation figure shown is PCB mounted and is for reference only.

■ ELECTRICAL CHARACTERISTICS

MYRGC075060W31RA / MYRGC075060B31RA

Ta=25°C

PARAMETER	SYMBOL	CONDITIONS	MIN.	TYP.	MAX.	UNIT	CIRCUIT	
FB Voltage	V _{FBE}	V _{FB} =0.739V→0.761V, FB Voltage when Lx pin voltage changes from "H" level to "L" level	0.739	0.750	0.761	V	②	
Output Voltage Setting Range (*1)	V _{OUTSET}	-	1.0	-	5.0	V	-	
Input Voltage Operating Range (*1)	V _{IN}	-	3.0	-	36.0	V	-	
UVLO Detect Voltage	V _{UVLOD}	V _{ENSS} =12V, V _{IN} =2.8V → 2.6V, V _{FB} =0V V _{IN} Voltage which Lx pin voltage holding "H" level	Ta=25°C	2.6	2.7	2.8	V	②
			Ta=-40~105°C(*2)	2.53	-	2.87		
UVLO Release Voltage	V _{UVLOR}	V _{ENSS} =12V, V _{IN} =2.7V → 2.9V, V _{FB} =0V V _{IN} Voltage which Lx pin voltage holding "L" level	Ta=25°C	2.7	2.8	2.9	V	②
			Ta=-40~105°C(*2)	2.63	-	2.97		
Quiescent Current (MYRGC075060W31RA)	I _q	V _{FB} =0.825V	-	180	350	μA	④	
Quiescent Current (MYRGC075060B31RA)	I _q	V _{FB} =0.825V	-	12.5	21.0	μA	④	
Stand-by Current	I _{STBY}	V _{IN} =12V, V _{ENSS} =V _{FB} =0V	-	1.65	2.50	μA	④	
Oscillation Frequency	f _{OSC}	Connected to external components, I _{OUT} =150mA	1.098	1.200	1.302	MHz	①	
Minimum On Time	t _{ONMIN}	Connected to external components	-	85 (*1)	-	ns	①	
Minimum Duty Cycle	D _{MIN}	V _{FB} =0.825V	-	-	0	%	②	
Maximum Duty Cycle	D _{MAX}	V _{FB} =0.675V	100	-	-	%	②	
Lx SW "H" On Resistance	R _{LxH}	V _{FB} =0.675V, I _{Lx} =200mA	-	1.20	1.38	Ω	⑤	
Lx SW "L" On Resistance	R _{LxL}		-	0.60(*1)	-	Ω	-	
High side Current Limit (*2)	I _{LIMH}	V _{FB} =V _{FBE} ×0.98	1.0	1.3	-	A	⑤	
Internal Soft-Start Time	t _{SS1}	V _{FB} =0.675V	1.6	2.0	2.4	ms	②	
External Soft-Start Time	t _{SS2}	V _{FB} =0.675V R _{SS} =430kΩ, C _{SS} =0.47μF	21	26	33	ms	③	
PFM Switch Current (MYRGC075060B31RA)	I _{PFM}	Connected to external components, V _{IN} =V _{ENSS} =12V, I _{OUT} =1mA	-	450	-	mA	①	
Efficiency	EFFI	Connected to external components, V _{IN} =12V, V _{OUT} =5V, I _{OUT} =300mA	-	86	-	%	①	
FB Voltage Temperature Characteristics	ΔV _{FB} / (ΔT _{opr} ·V _{FBE})	-40°C ≤ T _{opr} ≤ 105°C	-	±100	-	ppm/°C	②	

Test Condition: Unless otherwise stated, V_{IN}=12V, V_{ENSS}=12V, PG=OPEN

Peripheral parts connection conditions (V_{OUT}=5.0V): R_{FB1}=680kΩ, R_{FB2}=120kΩ, C_{FB}=15pF, C_L=22μF, C_{IN}=4.7μF

(*1) Design reference value. This parameter is provided only for reference.

(*2) Current limit denotes the level of detection at peak of coil current.

MYRGC075060W31RA / MYRGC075060B31RA

Ta=25°C

PARAMETER	SYMBOL	CONDITIONS	MIN.	TYP.	MAX.	UNIT	CIRCUIT	
PG Detect Voltage	V _{PGDET}	V _{FB} =0.712V→0.638V, R _{PG} :100kΩ pull-up to 5V FB Voltage when PG pin voltage changes from "H" level to "L" level	0.638	0.675	0.712	V	⑤	
PG Output Voltage	V _{PG}	V _{FB} =0.6V, I _{PG} =1mA	-	-	0.3	V	②	
FB "H" Current	I _{FBH}	V _{IN} =V _{EN/SS} =36V, V _{FB} =3.0V	-0.1	0.0	0.1	μA	④	
FB "L" Current	I _{FBL}	V _{IN} =V _{EN/SS} =36V, V _{FB} =0V	-0.1	0.0	0.1	μA	④	
EN/SS "H" Voltage	V _{EN/SSH}	V _{EN/SS} =0.3V→2.5V, V _{FB} =0.71V EN/SS Voltage when Lx pin voltage changes from "L" level to "H" level	Ta=25°C	2.5	-	36.0	V	②
			Ta=-40~105°C ^(*)					
EN/SS "L" Voltage	V _{EN/SSL}	V _{EN/SS} =2.5V→0.3V, V _{FB} =0.71V EN/SS Voltage when Lx pin voltage changes from "H" level to "L" level	Ta=25°C	GND	-	0.3	V	②
			Ta=-40~105°C ^(*)					
EN/SS "H" Current	I _{EN/SSH}	V _{IN} =V _{EN/SS} =36V, V _{FB} =0.825V	-	0.1	0.3	μA	④	
EN/SS "L" Current	I _{EN/SSL}	V _{IN} =36V, V _{EN/SS} =0V, V _{FB} =0.825V	-0.1	0.0	0.1	μA	④	
Thermal Shutdown Temperature	T _{TSD}	Junction Temperature	-	150	-	°C	-	
Thermal Shutdown Hysteresis Width	T _{HYS}	Junction Temperature	-	25	-	°C	-	
Inductance	L	Test Freq.=1MHz	-	4.7	-	μH	-	
Inductor Rated Current	I _{DC}	ΔT=+40°C	-	1.8	-	A	-	

 Test Condition: Unless otherwise stated, V_{IN}=12V, V_{EN/SS}=12V, PG=OPEN

(*) Design reference value. This parameter is provided only for reference.

■ TEST CIRCUITS

Circuit No.①

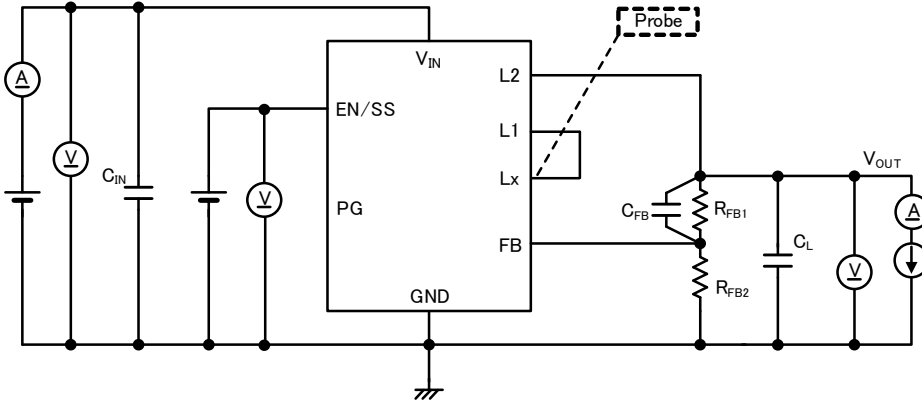

Circuit No.②

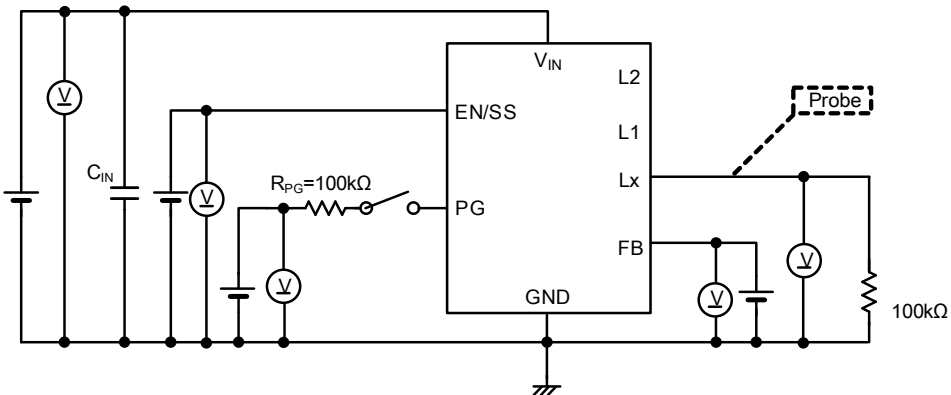

Circuit No.③

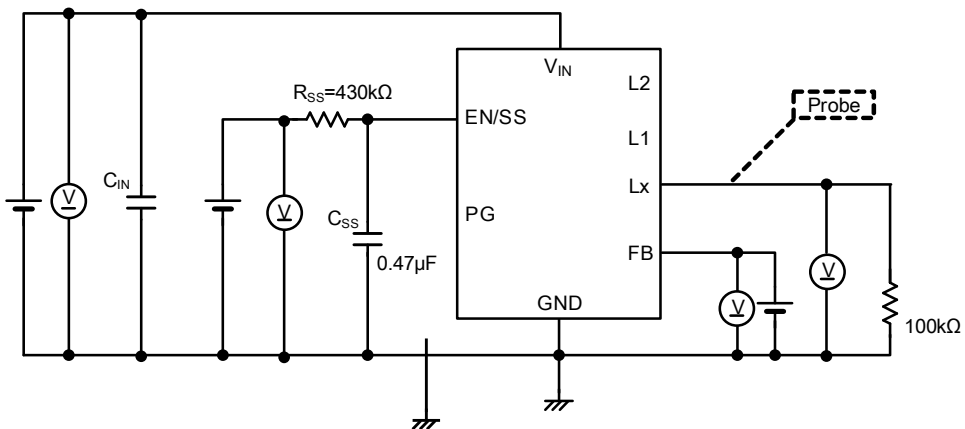

Circuit No.④

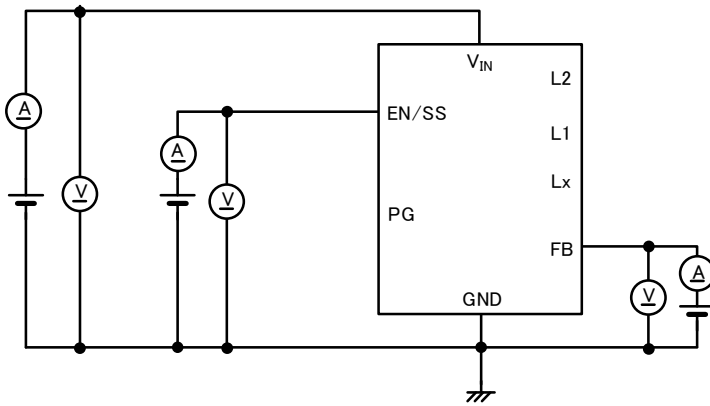

Circuit No.⑤

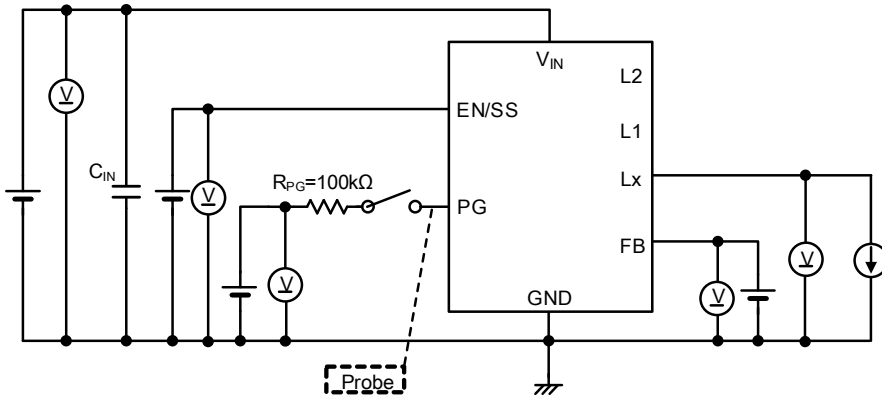

■ TYPICAL APPLICATION CIRCUIT / Parts Selection Method

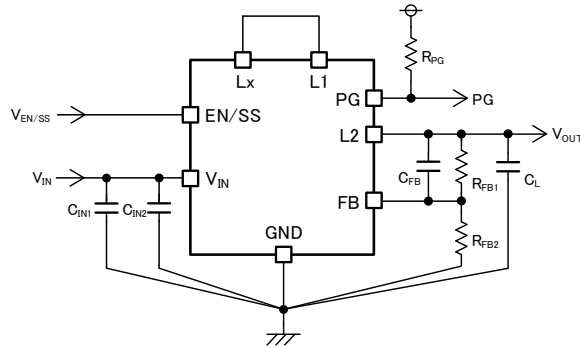

* The inductor is dedicated to this product. Please do not use it for purposes other than this product.

【Typical Example】

	VALUE
C _{IN1} (^{*1})	50V/4.7μF
C _{IN2}	50V/0.1μF
C _L (^{*2})	10V/10μF
	35V/10μF
	25V/22μF

Select parts considering the DC bias characteristics and rated voltage of ceramic capacitors.

(^{*1}) For C_{IN1}, use a capacitor with the same or higher effective capacity value as the recommended components.

(^{*2}) For C_L, use a capacitor with the same or higher effective capacity value as the recommended components.
If a capacitor with a low effective capacity value is used, the output voltage may become unstable.
However, if large capacity capacitors, such as electrolytic capacitors, are connected in parallel, the inrush current during startup could increase or the output could become unstable.

■ TYPICAL APPLICATION CIRCUIT / Parts Selection Method (Continued)

< Output Voltage Setting Value V_{OUTSET} Setting >

The output voltage can be set by adding an external dividing resistor.

The output voltage is determined by the equation below based on the values of R_{FB1} and R_{FB2} .

$$V_{OUTSET} = 0.75V \times (R_{FB1} + R_{FB2}) / R_{FB2}$$

With $R_{FB2} \leq 200k\Omega$ and $R_{FB1} + R_{FB2} \leq 1M\Omega$

< C_{FB} Setting >

Adjust the value of the phase compensation speed-up capacitor C_{FB} using the equation below.

$$C_{FB} = \frac{1}{2\pi \times f_{zfb} \times R_{FB1}}$$

$$f_{zfb} = \frac{1}{2\pi \sqrt{C_L \times L}}$$

【Setting Example】

When the output voltage setting is 5V with $f_{osc}=1.2MHz$, $C_L=22\mu F$, $L=4.7\mu H$,

$V_{OUTSET} = 0.75V \times (680k\Omega + 120k\Omega) / 120k\Omega = 5.0V$,

From the above formula, $f_{zfb} = 15.66kHz$ is targeted,

$C_{FB} = 1 / (2 \times \pi \times 15.66kHz \times 680k\Omega) = 14.95pF$, which is 15pF for the E24 series.

V_{OUTSET}	R_{FB1}	R_{FB2}	C_{FB}	Target f_{zfb}
1.2V	120k Ω	200k Ω	82pF	15.66kHz
3.3V	510k Ω	150k Ω	22pF	15.66kHz
5.0V	680k Ω	120k Ω	15pF	15.66kHz

OPERATIONAL EXPLANATION

The MYRGC075060W31RA / MYRGC075060B31RA consist internally of a reference voltage supply with soft-start function, a ramp wave circuit, an error amp, a PWM comparator, a High side driver FET, a Low side driver FET, a High side buffer circuit, a Low side buffer circuit, a current sense circuit, a phase compensation (Current feedback) circuit, a current limiting circuit, an under voltage lockout (UVLO) circuit, an internal power supply (Local Reg) circuit, a gate clamp (CLAMP) circuit and other elements. The control method is the current mode control method for handling low ESR ceramic capacitors.

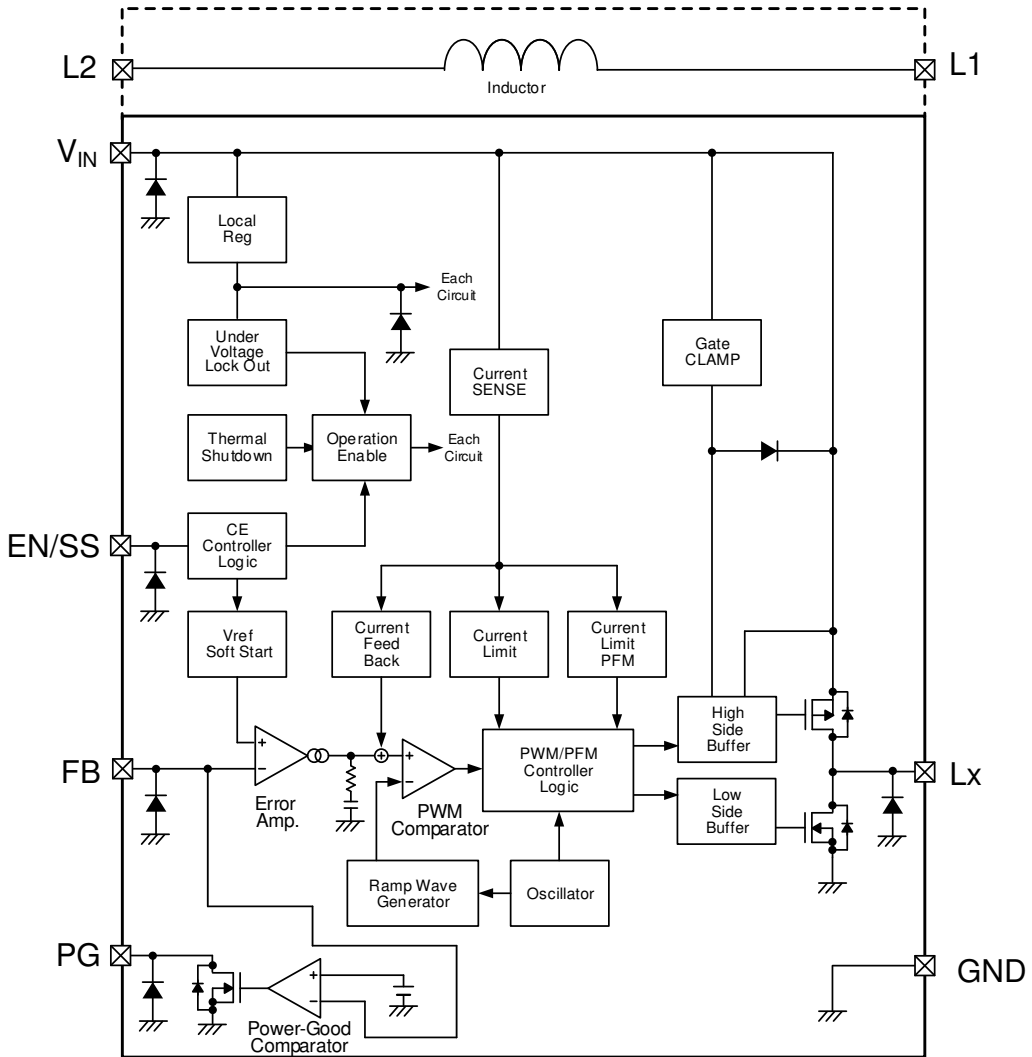

■ OPERATIONAL EXPLANATION (Continued)

< Normal Operation >

The standard voltage V_{ref} and FB pin voltage are compared using an error amplifier and then the control signal to which phase compensation has been added to the error amplifier output is input to the PWM comparator. The PWM comparator compares the above control signal and lamp wave to control the duty width during PWM control. Continuously conducting these controls stabilizes the output voltage.

In addition, the current detecting circuit monitors the driver FET current for each switching and modulates the error amplifier output signal into a multiple feedback signal (current feedback circuit). This achieves stable feedback control even when low ESR capacitors, such as ceramic capacitors, are used to stabilize the output voltage.

MYRGC075060W31RA

The MYRGC075060W31RA (PWM control) performs switching at a set switching frequency f_{osc} regardless of the output current. At light loads the on time is short and the circuit operates in discontinuous mode, and as the output current increases, the on time becomes longer and the circuit operates in continuous mode.

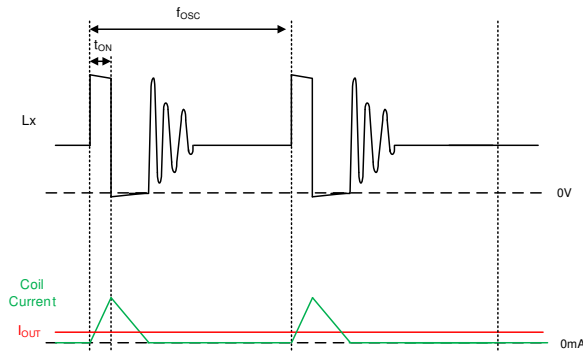

MYRGC075060W31RA: Example of light load operation

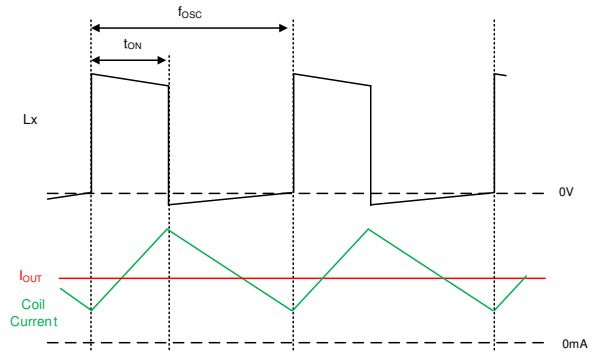

MYRGC075060W31RA: Example of heavy load operation

MYRGC075060B31RA

The MYRGC075060B31RA (PWM/PFM automatic switching control) lowers the switching frequency during light loads by turning on the High side driver FET when the coil current reaches the PFM current (I_{PFM}). This operation reduces the loss during light loads and achieves high efficiency from light to heavy loads. As the output current increases, the switching frequency increases proportional to the output current, and when the switching frequency increases f_{osc} , the circuit switches from PFM control to PWM control and the switching frequency becomes fixed.

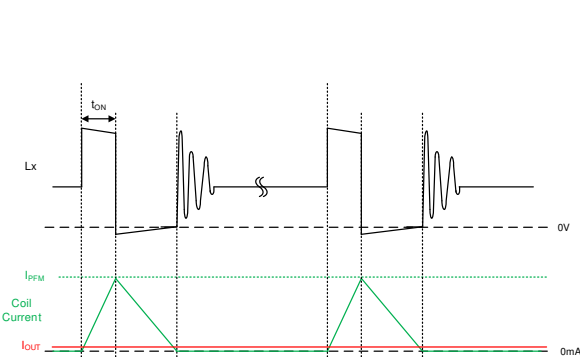

MYRGC075060B31RA: Example of light load operation

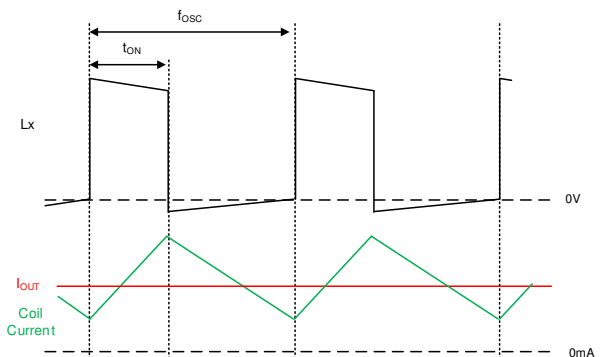

MYRGC075060B31RA: Example of heavy load operation

< 100% Duty Cycle Mode >

When the dropout voltage is low or there is a transient response, the circuit might change to the 100% Duty cycle mode where the High side driver FET is continuously on.

The 100% Duty cycle mode operation makes it possible to maintain the output current even when the dropout voltage is low such as when the input voltage declines due to cranking, etc.

OPERATIONAL EXPLANATION (Continued)

< CE Function >

When an “H” voltage ($V_{EN/SSH}$) is input to the EN/SS pin, normal operation is performed after the output voltage is started up by the soft start function, normal operation is performed. When the “L” voltage ($V_{EN/SSL}$) is input to the EN/SS pin, the circuit enters the standby state, the supply current is suppressed to the standby current I_{STB} (TYP.165 μ A), and the High side driver FET and Low side driver FET are turned off.

< Soft Start Function >

This function gradually starts up the output voltage to suppress the inrush current.

The soft start time is the time until the output voltage from $V_{EN/SSH}$ reaches 90% of the output voltage set value, and when the output voltage increases further, the soft start function is cancelled to switch to normal operation.

Internal Soft Start Time

The internal soft start time (t_{SS1}) is configured so that after the “H” voltage ($V_{EN/SSH}$) is input to the EN/SS pin, the standard voltage connected to the error amplifier increases linearly during the soft-start period. This causes the output voltage to increase proportionally to the standard voltage increase. This operation suppresses the inrush current and smoothly increases the output voltage.

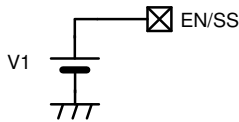

< Internal soft start EN/SS circuit >

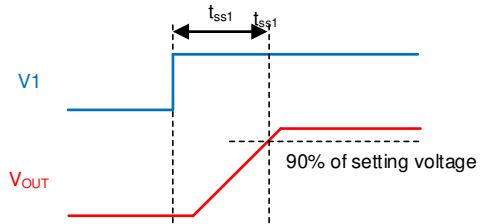

< Overview of internal soft start >

External Setting Soft Start Time

The external setting soft start time (t_{SS2}) can adjust the increase speed of the standard voltage in the IC by adjusting the EN/SS pin voltage inclination during startup using externally connected component R_{SS} and C_{SS} . This makes it possible to externally adjust the soft start time.

Soft start time (t_{SS2}) is approximated by the equation below according to values of $V1$, R_{SS} , and C_{SS} .
When t_{SS2} is shorter than t_{SS1} , the output voltage rises at the internal soft start time.

$$t_{SS2} = C_{SS} \times R_{SS} \times \ln \left(\frac{V1}{V1 - 1.45V} \right)$$

【Setting Example】

$C_{SS} = 0.47\mu\text{F}$, $R_{SS} = 430\text{k}\Omega$, $V1 = 12\text{V}$

$t_{SS2} = 0.47\mu\text{F} \times 430\text{k}\Omega \times \left(\ln \left(\frac{12\text{V}}{12\text{V} - 1.45\text{V}} \right) \right) = 26\text{ms}$

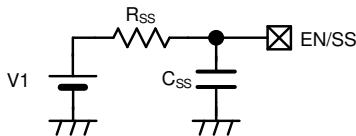

< External soft start EN/SS circuit >

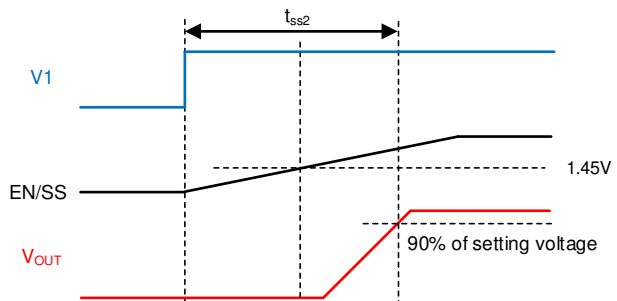

< Overview of external soft start >

■ OPERATIONAL EXPLANATION (Continued)

< Power Good >

The output state can be monitored using the power good function. The PG pin is an Nch open drain output, therefore a pull-up resistor (approx. 100kΩ) must be connected to the PG pin.

The pull-up voltage should be 5.5V or less. When not using the power good function, connect the PG terminal to GND or leave it open.

CONDITION		SIGNAL
EN/SS = H	$V_{FB} > V_{PGDET}$	H (High impedance)
	$V_{FB} \leq V_{PGDET}$	L (Low impedance)
	Thermal Shutdown	L (Low impedance)
	UVLO ($V_{IN} < V_{UVLO}$)	Undefined State
EN/SS = L	Stand-by	L (Low impedance)

< UVLO Function >

When the V_{IN} pin voltage falls below V_{UVLO} (TYP. 2.7V), the high side driver FET and low side driver FET are forcibly turned off to prevent false pulse output due to instable operation of the internal circuits. When the V_{IN} pin voltage rises above V_{UVLOR} (TYP. 2.8V), the UVLO function is released, the soft start function activates, and output start operation begins. Stopping by UVLO is not shutdown; only pulse output is stopped and the internal circuits continue to operate.

< Thermal Shutdown Function >

A thermal shutdown (TSD) function is built in for protection from overheating. When the junction temperature reaches the thermal shutdown detection temperature T_{TSD} , the High side driver FET and Low side driver FET are compulsorily turned off.

If the driver FET continues in the off state, the junction temperature declines, and when the junction temperature falls to the thermal shutdown cancel temperature, the thermal shutdown function is cancelled and the soft-start function operates to start up the output voltage.

■ OPERATIONAL EXPLANATION (Continued)

< Current Limit Function >

The current limiting circuit of the MYRGC075060W31RA / MYRGC075060B31RA monitors the current that flows through the High side driver FET and Low side driver FET, and when over current is detected, the current limiting function activates.

① High side driver FET current limiting

The current in the High side driver FET is detected to equivalently monitor the peak value of the coil current. The High side driver FET current limiting function forcibly turns off the High side driver FET when the peak value of the coil current reaches the High side driver current limit value I_{LIMH} .

High side driver FET current limit value $I_{LIMH}=1.3A(TYP.)$

② Low side driver FET current limiting

The current in the Low side driver FET is detected to equivalently monitor the bottom value of the coil current. The Low side driver FET current limiting function operates when the High side driver FET current limiting value reaches I_{LIMH} . The Low side driver FET current limiting function prohibits the High side driver FET from turning on in an over current state where the bottom value of the coil current is higher than the Low side driver FET current limit value I_{LIML} .

Low side driver FET current limit value $I_{LIML}=0.9A(TYP.)$

When the output current increases and reaches the current limit value, the current foldback circuit operates and lowers the output voltage and FB voltage. The I_{LIMH} and I_{LIML} decline accompanying the FB voltage decrease to restrict the output current.

When the overcurrent state is removed, the foldback circuit operation increases the I_{LIMH} and I_{LIML} together with output voltage to return the output to the output voltage set value.

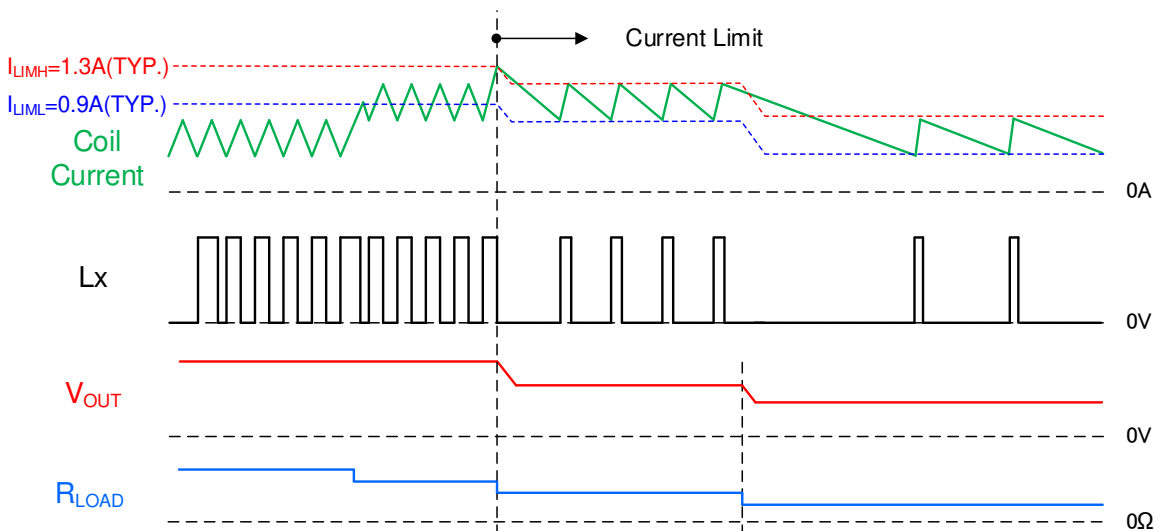

■ **NOTES ON USE**

- 1) In the case of a temporary and transient voltage drop or voltage rise.
If the absolute maximum ratings are exceeded, the IC may deteriorate or be destroyed.

If a voltage exceeding the absolute maximum voltage is applied to the IC due to chattering caused by a mechanical switch or an external surge voltage, please use a protection element such as a TVS and a protection circuit as a countermeasure.

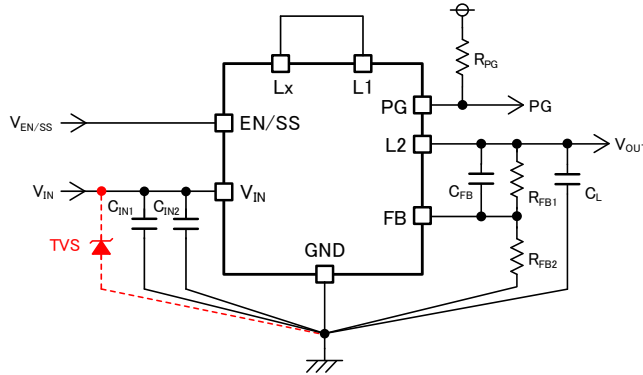

When the input voltage decreases below the output voltage, there is a possibility that an overcurrent will flow in the IC's internal parasitic diode and Lx pin. If the current is pulled into the input side by the low impedance between V_IN-GND, then countermeasures, such as adding an SBD between V_OUT-V_IN, should be taken.

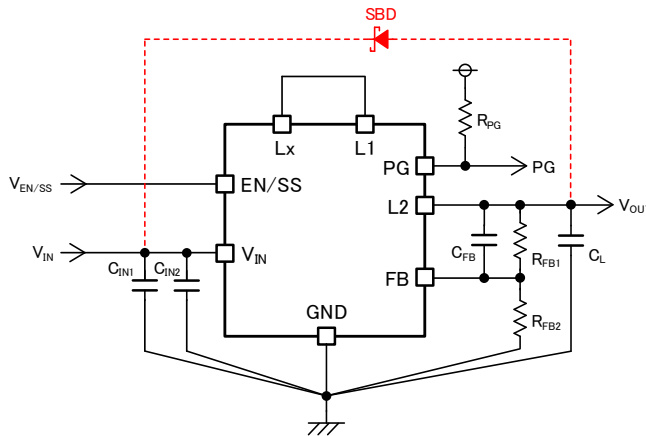

When a negative voltage is applied to the input voltage by a reverse connection or chattering, an overcurrent could flow in the IC's parasitic diode and damage the IC. Take countermeasures, such as adding a reverse touching protection diode.

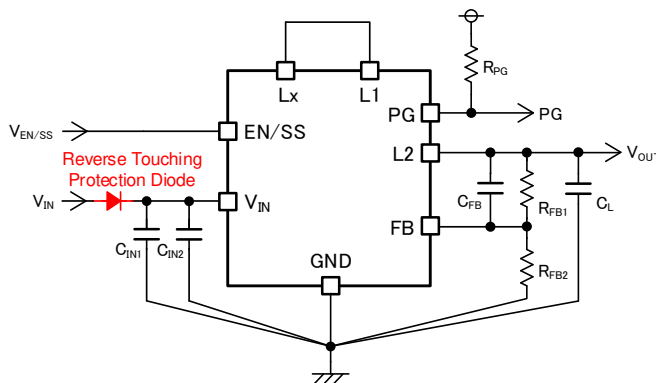

■ NOTES ON USE (Continued)

- 2) Make sure that the absolute maximum ratings of the external components and of this IC are not exceeded.
- 3) The DC/DC converter characteristics depend greatly on the externally connected components as well as on the characteristics of this IC, so refer to the specifications and standard circuit examples of each component when carefully considering which components to select.
Be especially careful of the capacitor characteristics and use X7R or X5R (EIA standard) ceramic capacitors.
The capacitance decrease caused by the bias voltage may become large depending on the external size of the capacitor.
- 4) The current limit value is the coil current peak value when switching is not conducted.
The coil current peak value when the actual current limit function begins to operate may exceed the current limit of the electrical characteristics due to the effect of the propagation delay inside the circuit.
- 5) When the On time is less than the Min On Time (t_{ONMIN}) and the dropout voltage is large or the load is low, the PWM control operates intermittently and the ripple voltage may become large or the output voltage may become unstable.
- 6) The ripple voltage could be increased when switching from discontinuous conduction mode to continuous conduction mode and when switching to 100% Duty cycle.
- 7) The PWM/PFM auto series may cause superimposed ripple voltage by continuous pulses if used in high temperature and no load conditions. It is necessary to set an idle current of higher than $100\mu\text{A}$ from V_{OUT} if used at no load.
It can have the same effect as when R_{FB2} is lower than $7.5\text{k}\Omega$. Please refer to the
< Output Voltage Setting Value V_{OUTSET} Setting > section under TYPICAL APPLICATION CIRCUIT.
- 8) If the voltage at the EN/SS Pin does not start from 0V but is at the midpoint potential when the power is switched on, the soft start function may not work properly and it may cause larger inrush current and bigger ripple voltages.
- 9) Murata places an importance on improving our products and their reliability. We request that users incorporate fail safe designs and post aging protection treatment when using Murata products in their systems.

■ NOTES ON USE (Continued)

10) Pattern Layout Instructions

- (1) The operation may become unstable due to noise and/or phase lag from the output current when the wire impedance is high. Please place the input capacitor (C_{IN1} , C_{IN2}) and the output capacitor (C_L) as close to the IC as possible.
- (2) In order to stabilize the V_{IN} voltage level, we recommend that a bypass capacitor (C_{IN1} , C_{IN2}) be connected as close as possible to the V_{IN} and GND pins.
- (3) Please mount each external component as close to the IC as possible.
- (4) Wire external components as close to the IC as possible and use thick, short connecting traces to reduce the circuit impedance.
- (5) Make sure that the GND traces are as thick as possible, as variations in ground potential caused by high ground currents at the time of switching may result in instability of the IC.
- (6) This product has a built in driver FET, which causes heat generation from the on resistance, so take measures to dissipate the heat when necessary.

< Reference Pattern Layout >

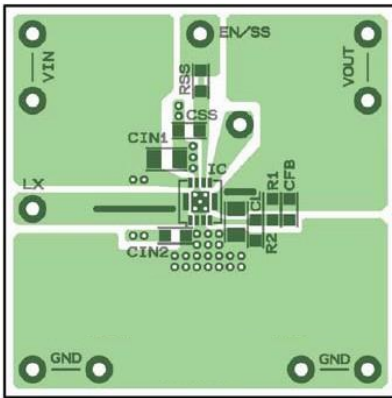

< Layer1 >

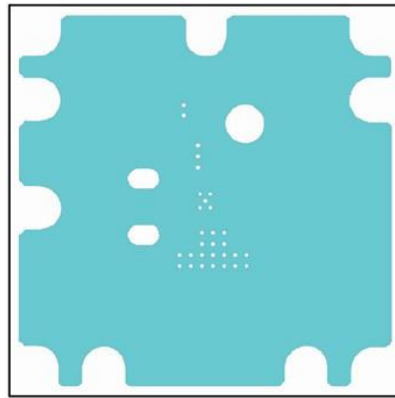

< Layer2 >

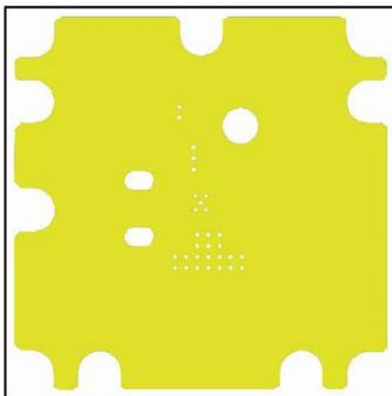

< Layer3 >

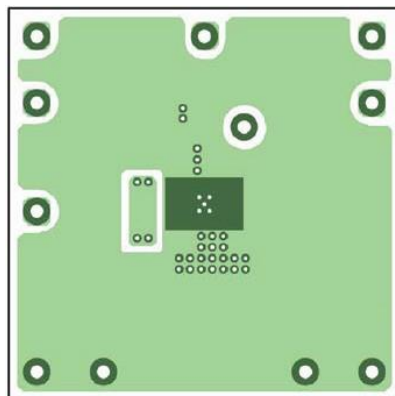

< Layer4 >

■ HANDLING OF THIS PRODUCT

- (1) The coil complies with the general surface-mounted type chip coil (inductor) specifications and could have scratches, be dirty with flux, etc.
- (2) Please do not use this product in the following environments:
Areas where it could come in to contact with water or salt water. Areas where it could be affected by condensation.
Areas where it could come in contact with toxic gases (Hydrogen Sulfide, Sulfurous Acid, Chlorine, Ammonia, etc.)
- (3) This product should not be washed in a solvent.

■ ABOUT IMPLEMENTATION

- (1) This product is only suitable for reflow soldering (it is not suitable for flow soldering).
- (2) This product uses solder to mount the coil on top of the package. This is no problem for regular circuit board mounted reflow, but if excessive impact is applied during reflow, the mounted coil could be moved out of position or the coil could fall off. Be careful not to strike the circuit board during circuit board mounting reflow.

■ TYPICAL PERFORMANCE CHARACTERISTICS

(1) Efficiency vs. Output Current

MYRGC075060W31RA
($V_{IN}=12V, V_{OUT}=3.3V$)
 $C_{IN1}=4.7\mu F, C_{IN2}=0.1\mu F, C_L=22\mu F$

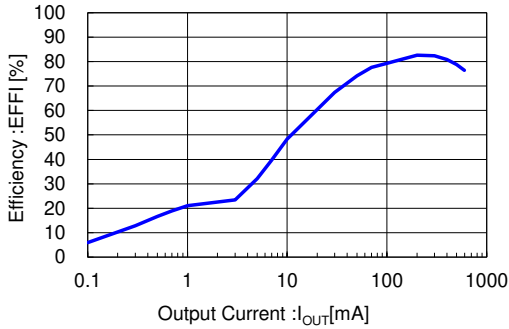

MYRGC075060W31RA
($V_{IN}=12V, V_{OUT}=5V$)
 $C_{IN1}=4.7\mu F, C_{IN2}=0.1\mu F, C_L=22\mu F$

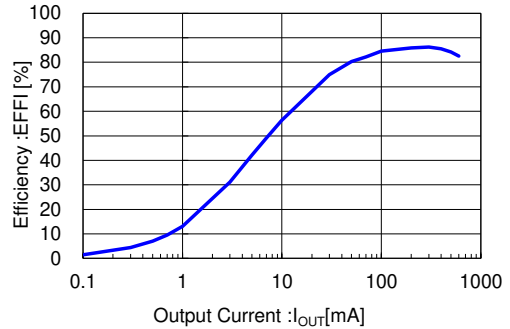

MYRGC075060B31RA
($V_{IN}=12V, V_{OUT}=3.3V$)
 $C_{IN1}=4.7\mu F, C_{IN2}=0.1\mu F, C_L=22\mu F$

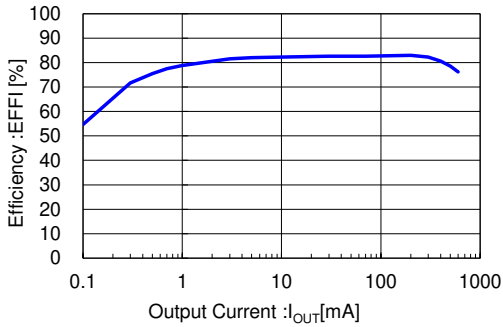

MYRGC075060B31RA
($V_{IN}=12V, V_{OUT}=5V$)
 $C_{IN1}=4.7\mu F, C_{IN2}=0.1\mu F, C_L=22\mu F$

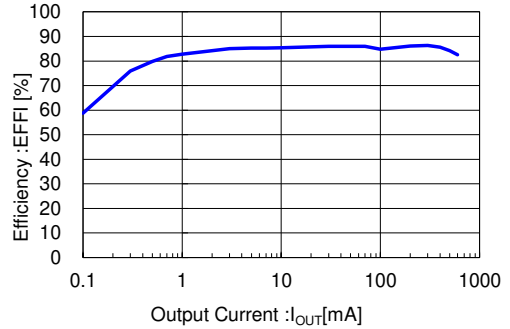

■ TYPICAL PERFORMANCE CHARACTERISTICS (Continued)

(2) Output Voltage vs. Output Current

MYRGC075060W31RA
($V_{IN}=12V, V_{OUT}=3.3V$)
 $C_{IN1}=4.7\mu F, C_{IN2}=0.1\mu F, C_L=22\mu F$

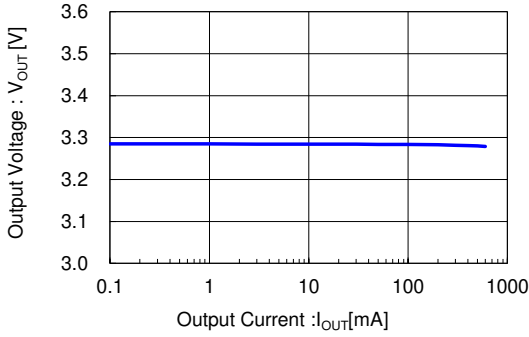

MYRGC075060W31RA
($V_{IN}=12V, V_{OUT}=5V$)
 $C_{IN1}=4.7\mu F, C_{IN2}=0.1\mu F, C_L=22\mu F$

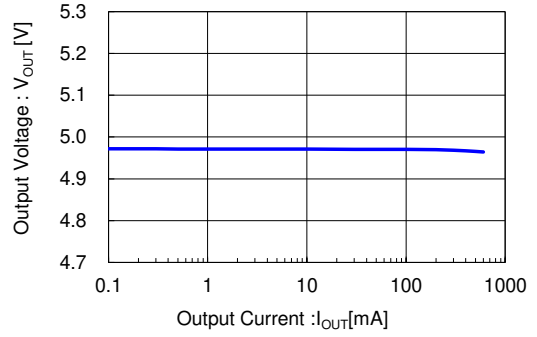

MYRGC075060B31RA
($V_{IN}=12V, V_{OUT}=3.3V$)
 $C_{IN1}=4.7\mu F, C_{IN2}=0.1\mu F, C_L=22\mu F$

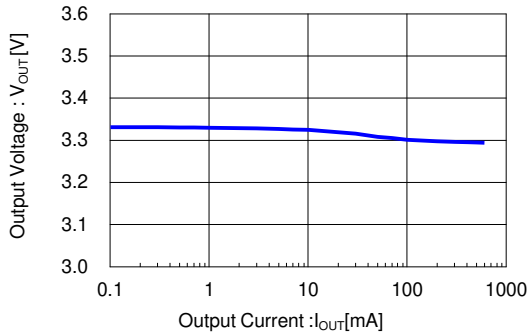

MYRGC075060B31RA
($V_{IN}=12V, V_{OUT}=5V$)
 $C_{IN1}=4.7\mu F, C_{IN2}=0.1\mu F, C_L=22\mu F$

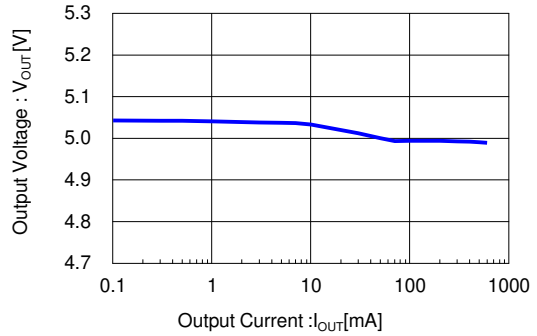

■ **TYPICAL PERFORMANCE CHARACTERISTICS (Continued)**

(3) Ripple Voltage vs. Output Current

MYRGC075060W31RA
($V_{IN}=12V, V_{OUT}=3.3V$)
 $C_{IN1}=4.7\mu F, C_{IN2}=0.1\mu F, C_L=22\mu F$

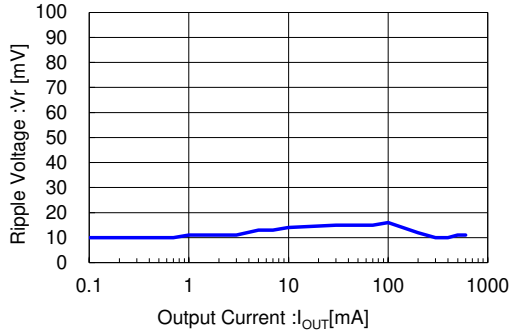

MYRGC075060W31R
($V_{IN}=12V, V_{OUT}=5V$)
 $C_{IN1}=4.7\mu F, C_{IN2}=0.1\mu F, C_L=22\mu F$

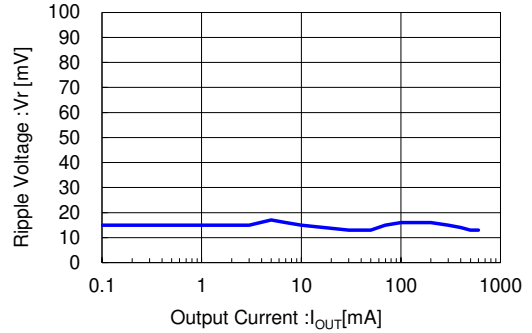

MYRGC075060B31RA
($V_{IN}=12V, V_{OUT}=3.3V$)
 $C_{IN1}=4.7\mu F, C_{IN2}=0.1\mu F, C_L=22\mu F$

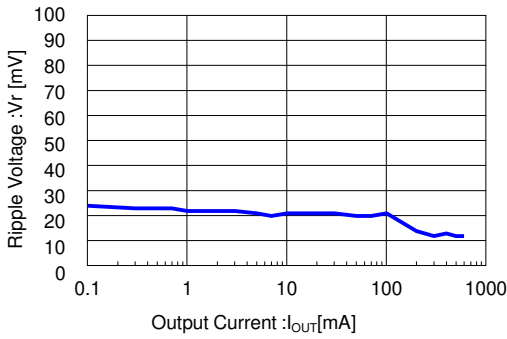

MYRGC075060B31R
($V_{IN}=12V, V_{OUT}=5V$)
 $C_{IN1}=4.7\mu F, C_{IN2}=0.1\mu F, C_L=22\mu F$

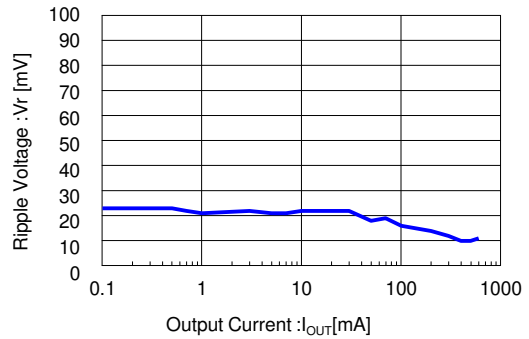

■ TYPICAL PERFORMANCE CHARACTERISTICS (Continued)

(4) FB Voltage vs. Ambient Temperature

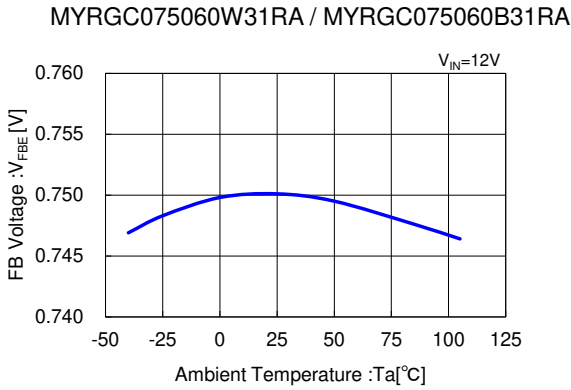

(5) UVLO Voltage vs. Ambient Temperature

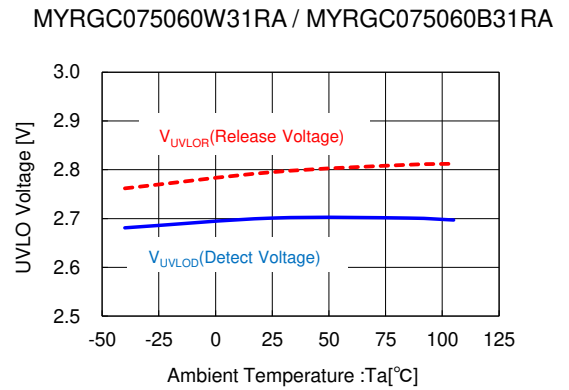

(6) Oscillation Frequency vs. Ambient Temperature

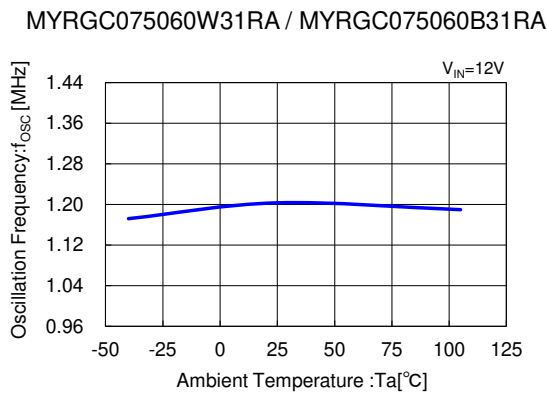

(7) Lx SW On Resistance vs. Ambient Temperature

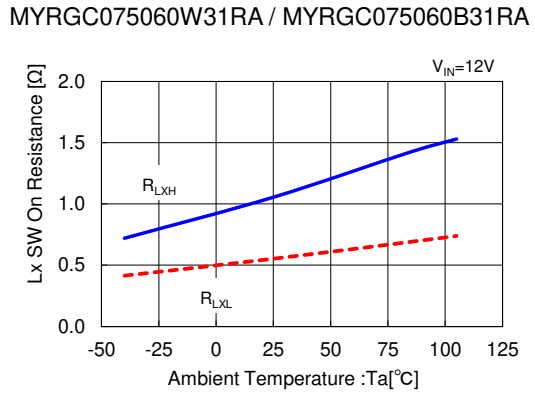

(8) Quiescent Current vs. Ambient Temperature

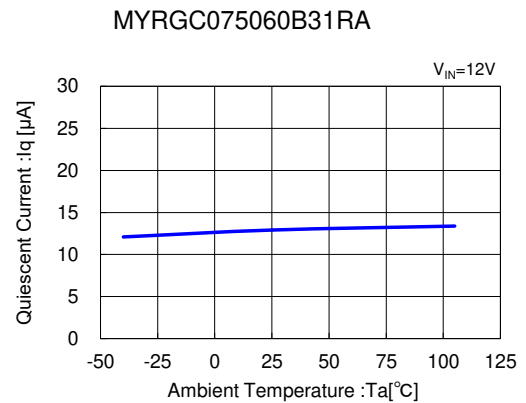
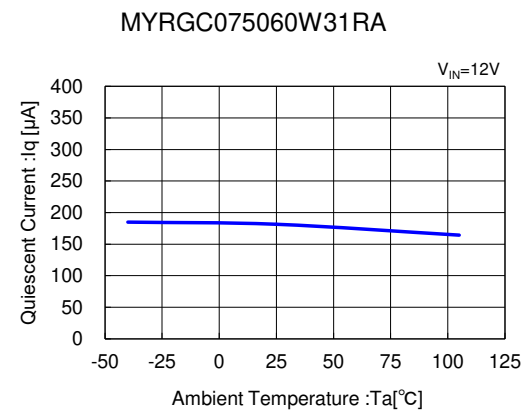

■ TYPICAL PERFORMANCE CHARACTERISTICS (Continued)

(9) Stand-by Current vs. Ambient Temperature

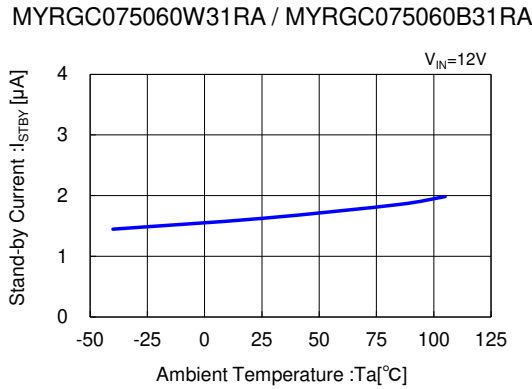

(10) EN/SS Voltage vs. Ambient Temperature

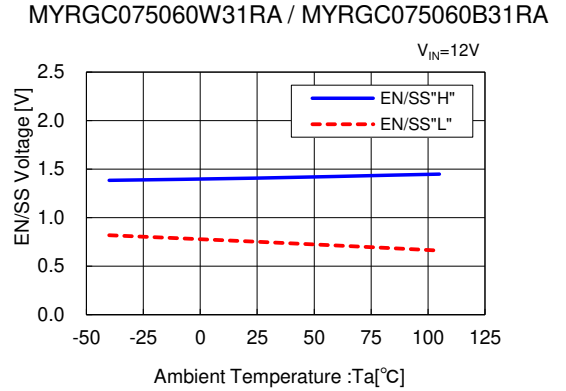

(11) Internal Soft-Start Time vs. Ambient Temperature

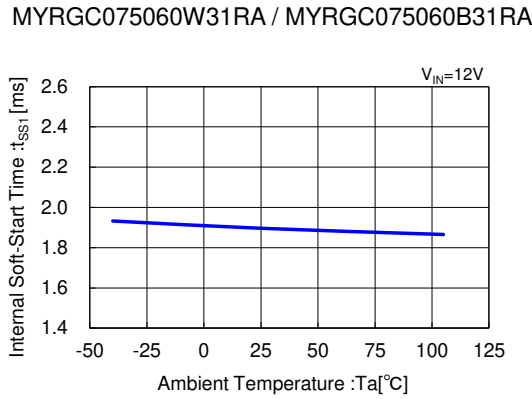

(12) External Soft-Start Time vs. Ambient Temperature

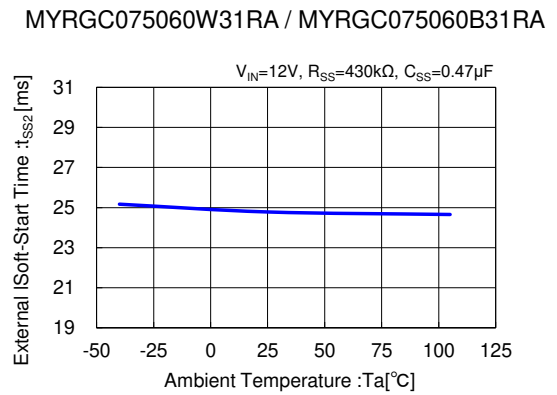

(13) PG Detect Voltage vs. Ambient Temperature

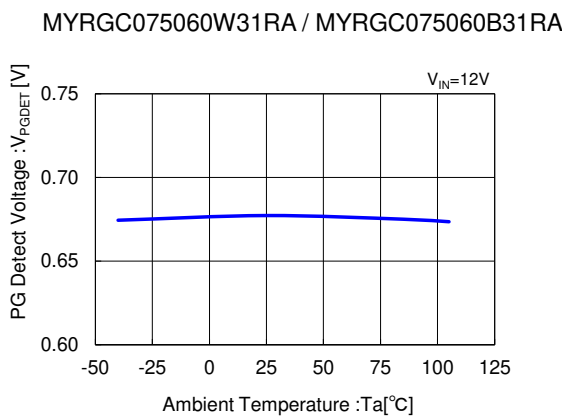

(14) PG Output Voltage vs. Ambient Temperature

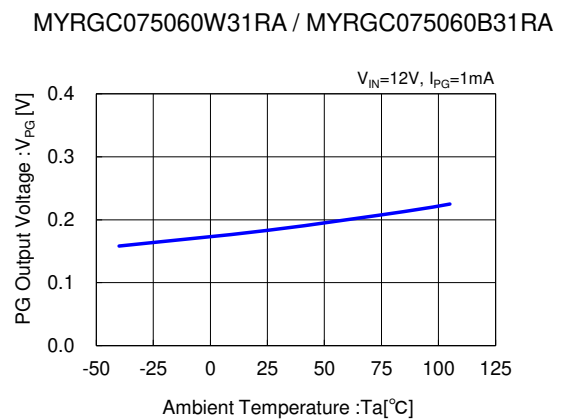

■ **TYPICAL PERFORMANCE CHARACTERISTICS (Continued)**

(15) V_{IN} - V_{OUT} Operation Area

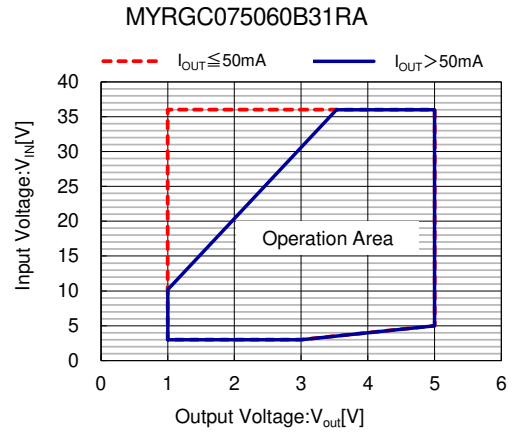
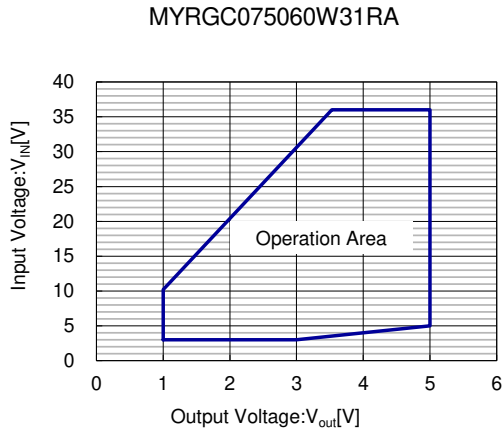

(16) Output Current Operation Area

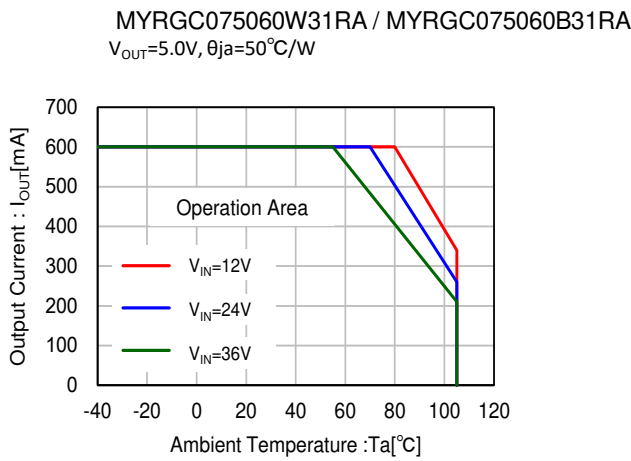

■ TYPICAL PERFORMANCE CHARACTERISTICS (Continued)

(17) Load Transient Response (MYRGC075060W31RA)

MYRGC075060W31RA

$V_{IN}=12V$, $V_{OUT}=3.3V$, $I_{OUT}=10mA \leftrightarrow 300mA$ ($t_r, t_f=5\mu s$)
 $C_{IN1}=4.7\mu F$, $C_{IN2}=0.1\mu F$, $C_L=22\mu F$

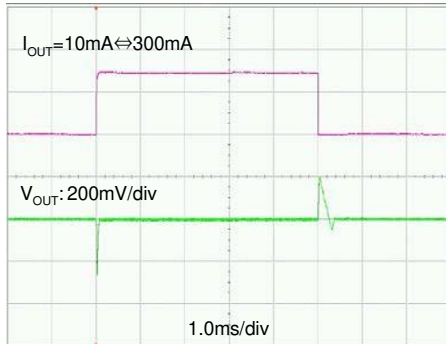

MYRGC075060W31RA

$V_{IN}=24V$, $V_{OUT}=3.3V$, $I_{OUT}=10mA \leftrightarrow 300mA$ ($t_r, t_f=5\mu s$)
 $C_{IN1}=4.7\mu F$, $C_{IN2}=0.1\mu F$, $C_L=22\mu F$

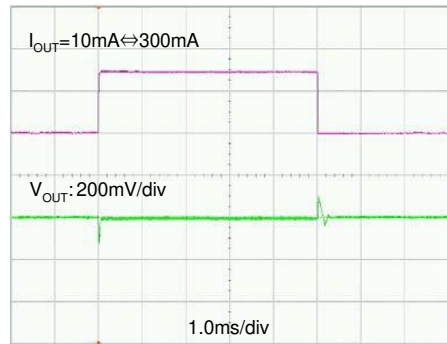

MYRGC075060W31RA

$V_{IN}=12V$, $V_{OUT}=5.0V$, $I_{OUT}=10mA \leftrightarrow 300mA$ ($t_r, t_f=5\mu s$)
 $C_{IN1}=4.7\mu F$, $C_{IN2}=0.1\mu F$, $C_L=22\mu F$

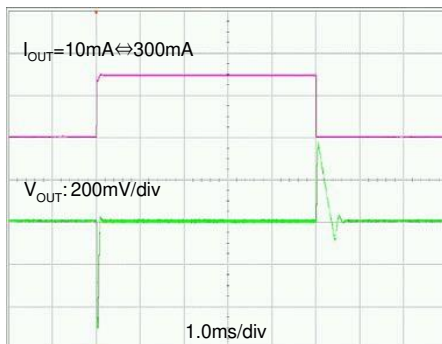

MYRGC075060W31RA

$V_{IN}=24V$, $V_{OUT}=5.0V$, $I_{OUT}=10mA \leftrightarrow 300mA$ ($t_r, t_f=5\mu s$)
 $C_{IN1}=4.7\mu F$, $C_{IN2}=0.1\mu F$, $C_L=22\mu F$

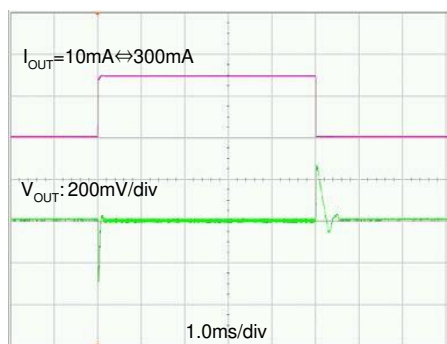

■ TYPICAL PERFORMANCE CHARACTERISTICS (Continued)

(17) Load Transient Response (MYRGC075060B31RA)

MYRGC075060B31RA
 $V_{IN}=12V$, $V_{OUT}=3.3V$, $I_{OUT}=10mA \leftrightarrow 300mA$ ($t_r, t_f=5\mu s$)
 $C_{IN1}=4.7\mu F$, $C_{IN2}=0.1\mu F$, $C_L=22\mu F$

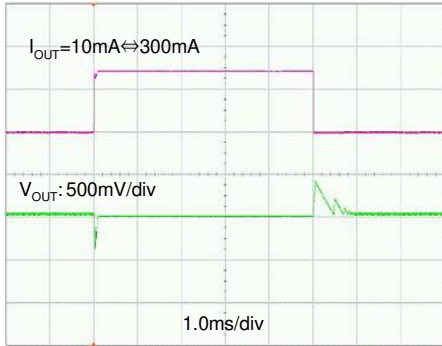

MYRGC075060B31RA
 $V_{IN}=24V$, $V_{OUT}=3.3V$, $I_{OUT}=10mA \leftrightarrow 300mA$ ($t_r, t_f=5\mu s$)
 $C_{IN1}=4.7\mu F$, $C_{IN2}=0.1\mu F$, $C_L=22\mu F$

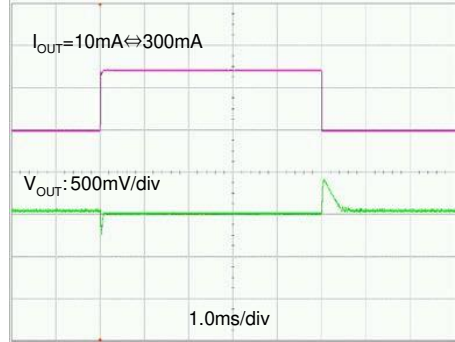

MYRGC075060B31RA
 $V_{IN}=12V$, $V_{OUT}=5.0V$, $I_{OUT}=10mA \leftrightarrow 300mA$ ($t_r, t_f=5\mu s$)
 $C_{IN1}=4.7\mu F$, $C_{IN2}=0.1\mu F$, $C_L=22\mu F$

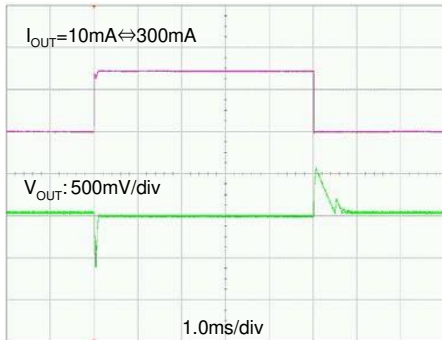

MYRGC075060B31RA
 $V_{IN}=24V$, $V_{OUT}=5.0V$, $I_{OUT}=10mA \leftrightarrow 300mA$ ($t_r, t_f=5\mu s$)
 $C_{IN1}=4.7\mu F$, $C_{IN2}=0.1\mu F$, $C_L=22\mu F$

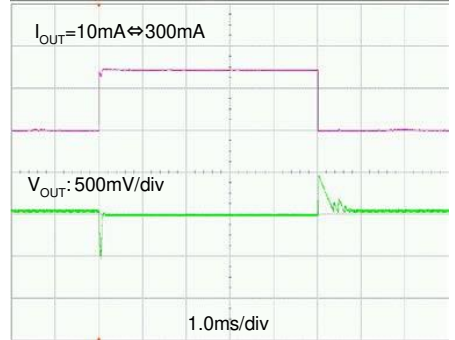

■ TYPICAL PERFORMANCE CHARACTERISTICS (Continued)

(18) Input Transient Response (MYRGC075060W31RA)

MYRGC075060W31RA
 $V_{IN}=8V \leftrightarrow 16V$ ($t_r, t_f=50\mu s$), $V_{OUT}=3.3V$, $I_{OUT}=300mA$
 $C_{IN1}=4.7\mu F$, $C_{IN2}=0.1\mu F$, $C_L=22\mu F$

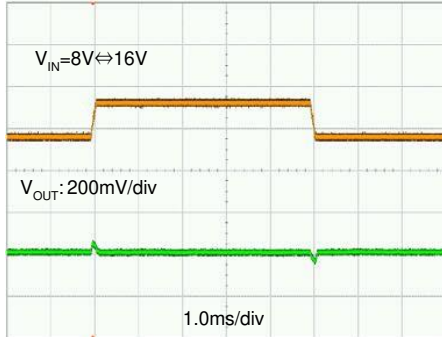

MYRGC075060W31RA
 $V_{IN}=16V \leftrightarrow 32V$ ($t_r, t_f=50\mu s$), $V_{OUT}=3.3V$, $I_{OUT}=300mA$
 $C_{IN1}=4.7\mu F$, $C_{IN2}=0.1\mu F$, $C_L=22\mu F$, $V_{IN}=16V \leftrightarrow 32V$

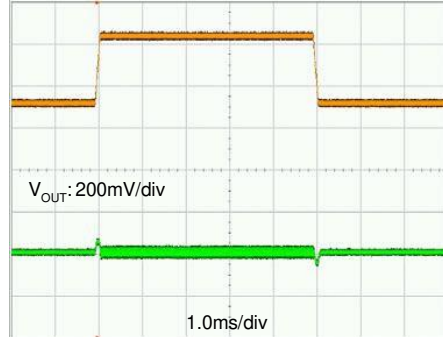

MYRGC075060W31RA
 $V_{IN}=8V \leftrightarrow 16V$ ($t_r, t_f=50\mu s$), $V_{OUT}=5.0V$, $I_{OUT}=300mA$
 $C_{IN1}=4.7\mu F$, $C_{IN2}=0.1\mu F$, $C_L=22\mu F$

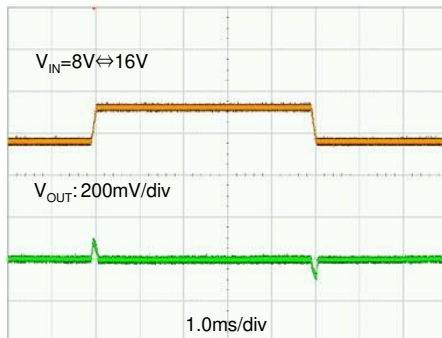

MYRGC075060W31RA
 $V_{IN}=16V \leftrightarrow 32V$ ($t_r, t_f=50\mu s$), $V_{OUT}=5.0V$, $I_{OUT}=300mA$
 $C_{IN1}=4.7\mu F$, $C_{IN2}=0.1\mu F$, $C_L=22\mu F$, $V_{IN}=16V \leftrightarrow 32V$

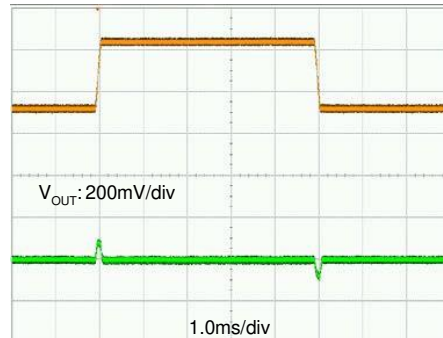

■ TYPICAL PERFORMANCE CHARACTERISTICS (Continued)

(18) Input Transient Response (MYRGC075060B31RA)

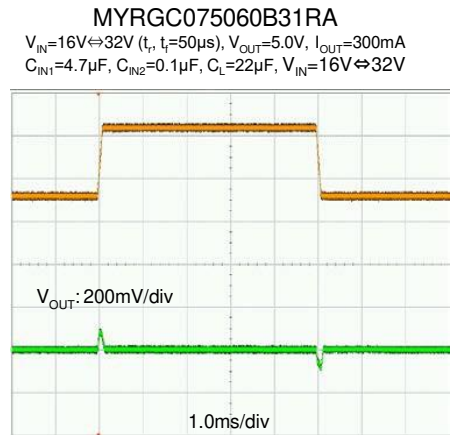
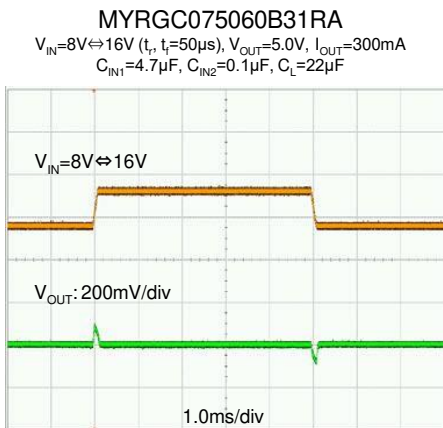
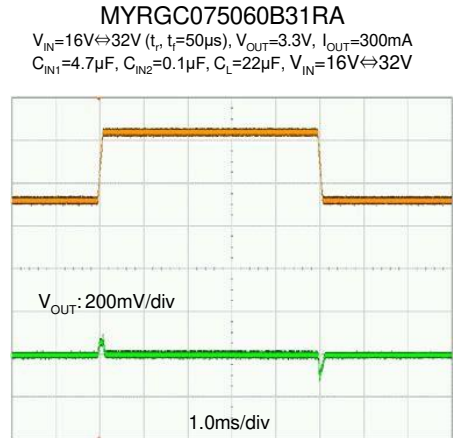
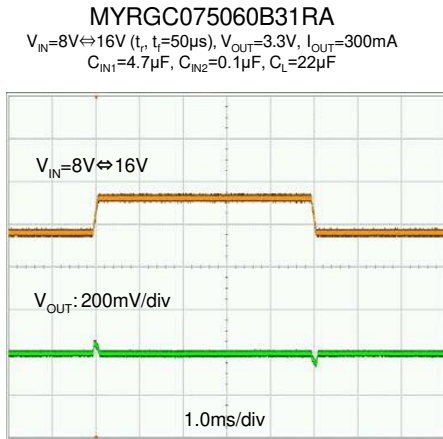

■ TYPICAL PERFORMANCE CHARACTERISTICS (Continued)

(19) EN/SS Rising Response (MYRGC075060W31RA)

MYRGC075060W31RA
 $V_{IN}=12V$, $V_{EN/SS}=0V \rightarrow 12V$ ($t_r=50\mu s$), $V_{OUT}=3.3V$, $I_{OUT}=300mA$
 $C_{IN1}=4.7\mu F$, $C_{IN2}=0.1\mu F$, $C_L=22\mu F$

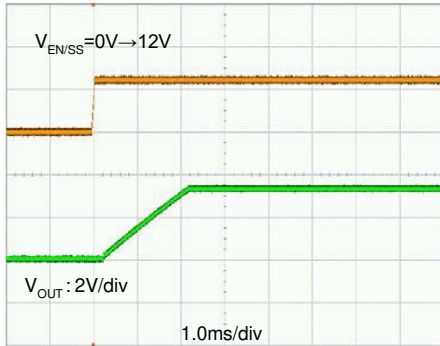

MYRGC075060W31RA
 $V_{IN}=24V$, $V_{EN/SS}=0V \rightarrow 24V$ ($t_r=50\mu s$), $V_{OUT}=3.3V$, $I_{OUT}=300mA$
 $C_{IN1}=4.7\mu F$, $C_{IN2}=0.1\mu F$, $C_L=22\mu F$

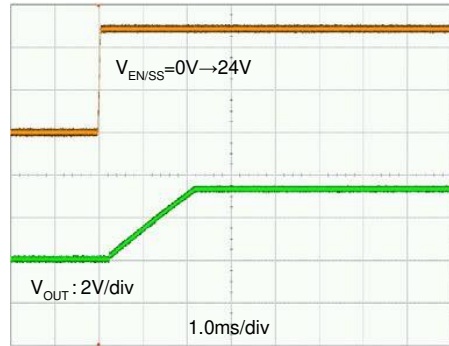

MYRGC075060W31RA
 $V_{IN}=12V$, $V_{EN/SS}=0V \rightarrow 12V$ ($t_r=50\mu s$), $V_{OUT}=5.0V$, $I_{OUT}=300mA$
 $C_{IN1}=4.7\mu F$, $C_{IN2}=0.1\mu F$, $C_L=22\mu F$

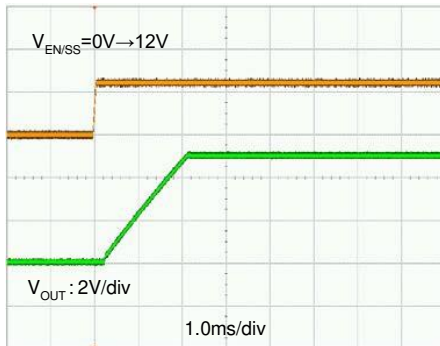

MYRGC075060W31RA
 $V_{IN}=24V$, $V_{EN/SS}=0V \rightarrow 24V$ ($t_r=50\mu s$), $V_{OUT}=5.0V$, $I_{OUT}=300mA$
 $C_{IN1}=4.7\mu F$, $C_{IN2}=0.1\mu F$, $C_L=22\mu F$

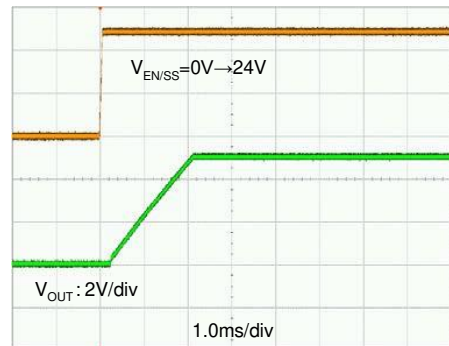

■ TYPICAL PERFORMANCE CHARACTERISTICS (Continued)

(19) EN/SS Rising Response (MYRGC075060B31RA)

MYRGC075060B31RA
 $V_{IN}=12V$, $V_{EN/SS}=0V \rightarrow 12V$ ($t_r=50\mu s$), $V_{OUT}=3.3V$, $I_{OUT}=300mA$
 $C_{IN1}=4.7\mu F$, $C_{IN2}=0.1\mu F$, $C_L=22\mu F$

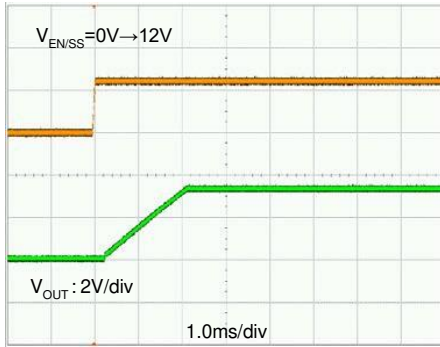

MYRGC075060B31RA
 $V_{IN}=24V$, $V_{EN/SS}=0V \rightarrow 24V$ ($t_r=50\mu s$), $V_{OUT}=3.3V$, $I_{OUT}=300mA$
 $C_{IN1}=4.7\mu F$, $C_{IN2}=0.1\mu F$, $C_L=22\mu F$

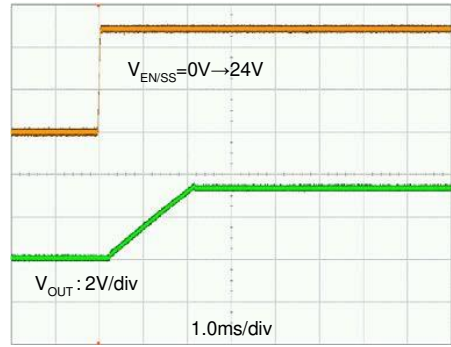

MYRGC075060B31RA
 $V_{IN}=12V$, $V_{EN/SS}=0V \rightarrow 12V$ ($t_r=50\mu s$), $V_{OUT}=5.0V$, $I_{OUT}=300mA$
 $C_{IN1}=4.7\mu F$, $C_{IN2}=0.1\mu F$, $C_L=22\mu F$

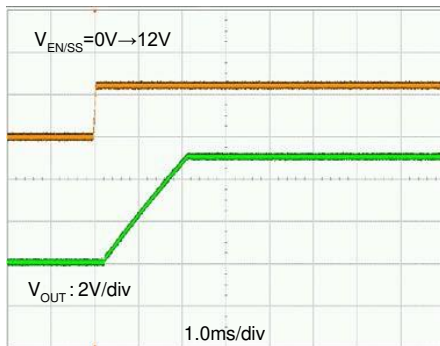

MYRGC075060B31RA
 $V_{IN}=24V$, $V_{EN/SS}=0V \rightarrow 24V$ ($t_r=50\mu s$), $V_{OUT}=5.0V$, $I_{OUT}=300mA$
 $C_{IN1}=4.7\mu F$, $C_{IN2}=0.1\mu F$, $C_L=22\mu F$

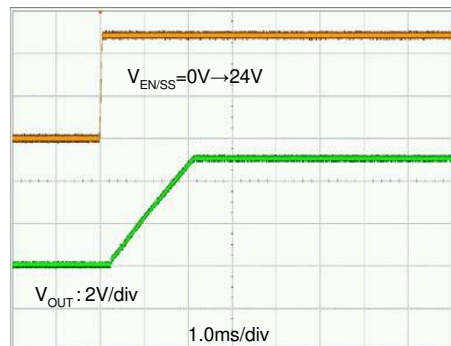

■ TYPICAL PERFORMANCE CHARACTERISTICS (Continued)

(20) V_{IN} Rising Response (MYRGC075060W31RA)

MYRGC075060W31RA
 $V_{IN}=0V \rightarrow 12V$ ($tr=50\mu s$), $V_{EN/SS}=V_{IN}$, $V_{OUT}=3.3V$, $I_{OUT}=300mA$
 $C_{IN1}=4.7\mu F$, $C_{IN2}=0.1\mu F$, $C_L=22\mu F$

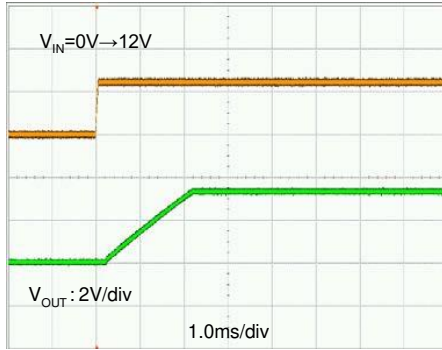

MYRGC075060W31RA
 $V_{IN}=0V \rightarrow 24V$ ($tr=50\mu s$), $V_{EN/SS}=V_{IN}$, $V_{OUT}=3.3V$, $I_{OUT}=300mA$
 $C_{IN1}=4.7\mu F$, $C_{IN2}=0.1\mu F$, $C_L=22\mu F$

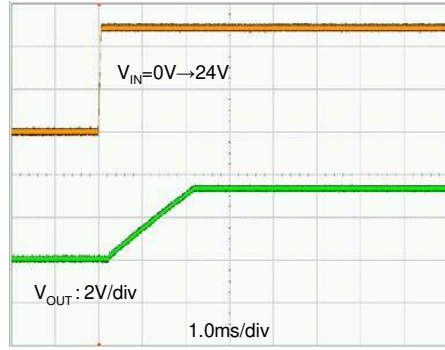

MYRGC075060W31RA
 $V_{IN}=0 \rightarrow 12V$ ($tr=50\mu s$), $V_{EN/SS}=V_{IN}$, $V_{OUT}=5.0V$, $I_{OUT}=300mA$
 $C_{IN1}=4.7\mu F$, $C_{IN2}=0.1\mu F$, $C_L=22\mu F$

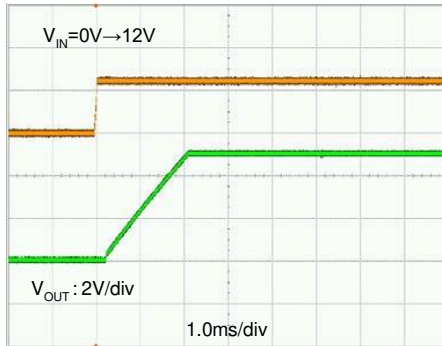

MYRGC075060W31RA
 $V_{IN}=0 \rightarrow 24V$ ($tr=50\mu s$), $V_{EN/SS}=V_{IN}$, $V_{OUT}=5.0V$, $I_{OUT}=300mA$
 $C_{IN1}=4.7\mu F$, $C_{IN2}=0.1\mu F$, $C_L=22\mu F$

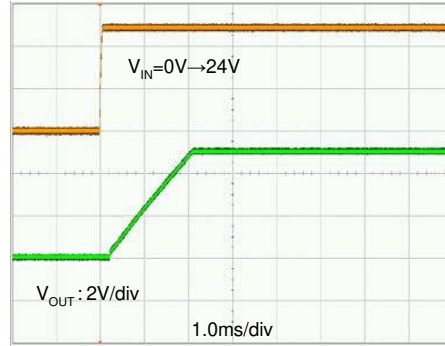

■ **TYPICAL PERFORMANCE CHARACTERISTICS (Continued)**

(20) V_{IN} Rising Response (MYRGC075060B31RA)

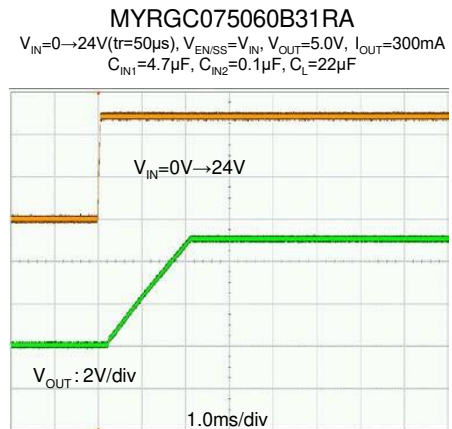
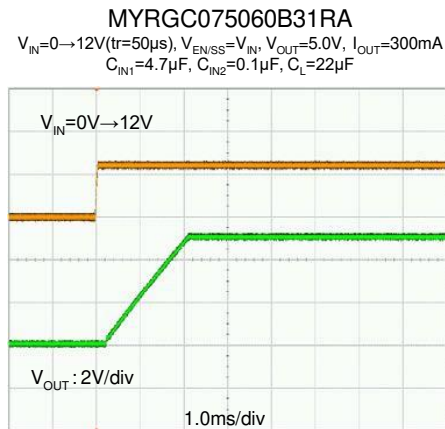
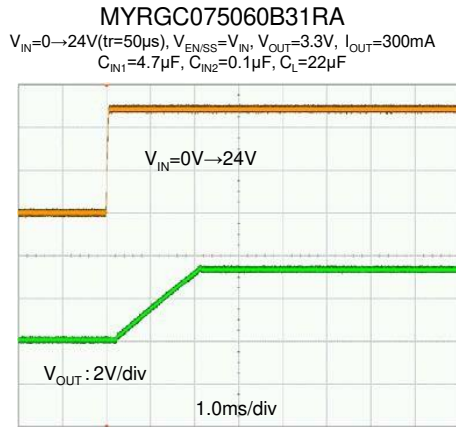
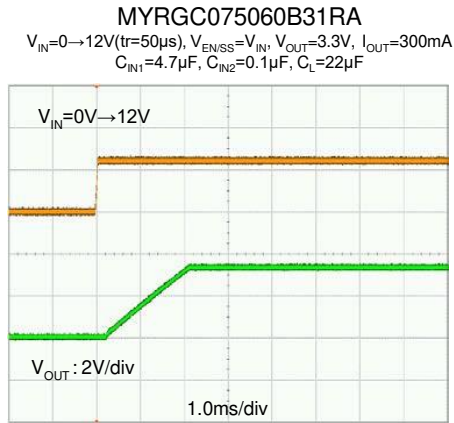

■ PACKAGING INFORMATION

1. Power Dissipation

Power dissipation data for this packaging is shown in this page.
The value of power dissipation varies with the mount board conditions.
Please use this data as one of reference data taken in the described condition.

1. Measurement Condition (Reference data)

- Condition : Mount on a board
- Ambient : Natural convection
- Soldering : Lead (Pb) free
- Board : The board using 4 copper layer.
(76.2mm x 114.3mm ··· Area: about 8700mm²)
- 1st layer : No copper foil (Signal layer)
- 2nd layer : 70mm x 70mm_Conected to heat-sink.
- 3rd layer : 70mm x 70mm_Conected to heat-sink.
- 4th layer : No copper foil (Signal layer)
- Material : Glass Epoxy(FR-4)
- Thickness : 1.6mm
- Through-hole : 0.2mm x 60pcs

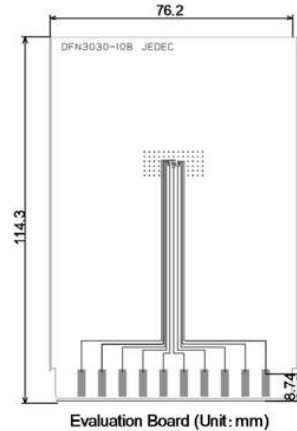

2. Power Dissipation vs. Ambient Temperature

Board Mount (Tj max = 125°C)

Ambient Temperature (°C)	Power Dissipation Pd (mW)	Thermal Resistance (°C/W)
25	1950	51.28
105	390	

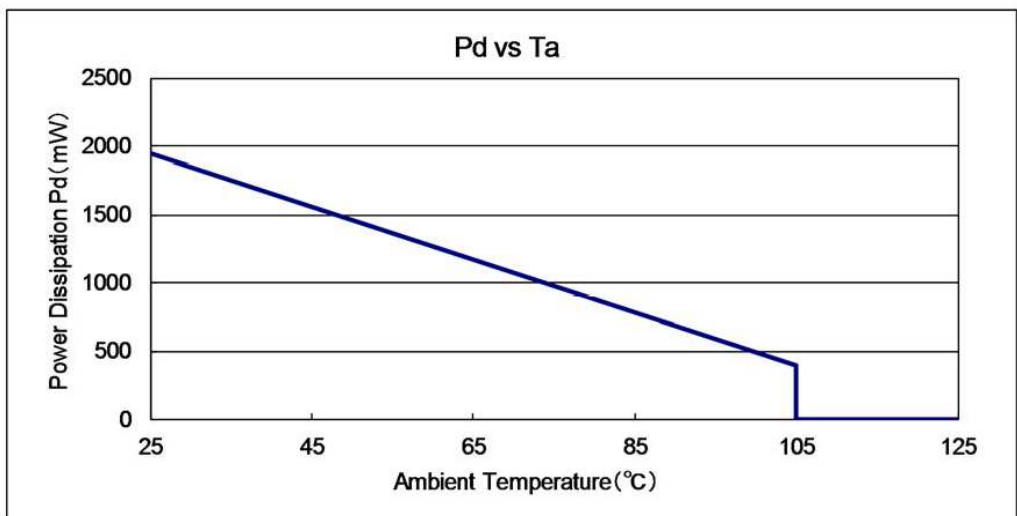

■ MARKING RULE

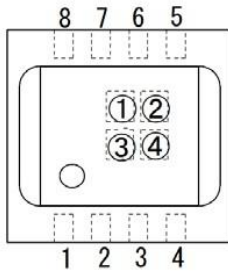

Mark ①,②, represents product series, products-type.

SYMBOL		Series Name	Part Number
①	②		
T	N	MYRGC-W	MYRGC075060W31RA
T	T	MYRGC-B	MYRGC075060B31RA

Mark ③,④, represents production lot number. 01~09,
0A~0Z, 11~9Z, A1~A9, AA~B1~ZZ, repeated.
(G, I, J, O, Q, W excluded) No character inversion used.

1. The product and product specifications contained herein are subject to change without notice to improve performance characteristics. Consult us, or our representatives before use, to confirm that the information in this datasheet is up to date.
2. The information in this datasheet is intended to illustrate the operation and characteristics of our products. We neither make warranties or representations with respect to the accuracy or completeness of the information contained in this datasheet nor grant any license to any intellectual property rights of ours or any third party concerning with the information in this datasheet.
3. Applicable export control laws and regulations should be complied and the procedures required by such laws and regulations should also be followed, when the product or any information contained in this datasheet is exported.
4. The product is neither intended nor warranted for use in equipment of systems which require extremely high levels of quality and/or reliability and/or a malfunction or failure which may cause loss of human life, bodily injury, serious property damage including but not limited to devices or equipment used in 1) nuclear facilities, 2) aerospace industry, 3) medical facilities, 4) automobile industry and other transportation industry and 5) safety devices and safety equipment to control combustions and explosions. Do not use the product for the above use unless agreed by us in writing in advance.
5. Although we make continuous efforts to improve the quality and reliability of our products; nevertheless Semiconductors are likely to fail with a certain probability. So in order to prevent personal injury and/or property damage resulting from such failure, customers are required to incorporate adequate safety measures in their designs, such as system fail safes, redundancy and fire prevention features.
6. Our products are not designed to be Radiation-resistant.
7. Please use the product listed in this datasheet within the specified ranges.
8. We assume no responsibility for damage or loss due to abnormal use.

Murata Manufacturing Co., Ltd