

# APPROVAL SHEET

## MULTILAYER CERAMIC CAPACITORS

Soft Termination Series

(SH\_6.3V to 3000V)

NP0, X7R & X5R Dielectrics

0402 to 2225 Sizes

Halogen Free & RoHS Compliance

\*Contents in this sheet are subject to change without prior notice.

## 1. INTRODUCTION

WTC soft termination series MLCC is designed and with a polymer layer within end terminations of product, which can absorb mechanical stress caused by PCB handling in SMT line and reduce the mechanical impact for product. It will offer more robust and reliable performance in applications.

## 2. FEATURES

- a. MLCC's termination are with a soft & flexible polymer layer to withstand high bending stress in SMT line.
- b. Available for any item in standard series range.

## 3. APPLICATIONS

- a. Power supply and related industries.
- b. Lighting industry.
- c. The other mechanical stress concerned products.

## 4. HOW TO ORDER

<u>SH</u>	<u>31</u>	<u>B</u>	<u>104</u>	<u>K</u>	<u>500</u>	<u>C</u>	<u>I</u>
<u>Series</u>	<u>Size</u>	<u>Dielectric</u>	<u>Capacitance</u>	<u>Tolerance</u>	<u>Rated voltage</u>	<u>Termination</u>	<u>Packaging</u>
SH=Soft termination	15=0402 (1005) 18=0603 (1608) 21=0805 (2012) 31=1206 (3216) 32=1210 (3225) 42=1808 (4520) 43=1812 (4532) 46=1825 (4563) 55=2220 (5750) 56=2225 (5763)	N=NP0 (COG) B=X7R X=X5R	Two significant digits followed by no. of zeros. And R is in place of decimal point. Eg. 104=10x10 <sup>4</sup> =100nF	B=±0.1pF C=±0.25pF D=±0.5pF F=±1% G=±2% J=±5% K=±10% M=±20%	Two significant digits followed by no. of zeros. And R is in place of decimal point.  6R3=6.3 VDC 100=10 VDC 160=16 VDC 250=25 VDC 500=50 VDC 101=100 VDC 201=200 VDC 251=250 VDC 401=400 VDC 451=450 VDC 501=500 VDC 631=630 VDC 102=1000 VDC 152=1500 VDC 202=2000 VDC 252= 2500 VDC 302=3000 VDC	C=Ag Polymer /Ni/Sn	T=7" reeled G=13" reeled

Multilayer Ceramic Capacitors

5. EXTERNAL DIMENSIONS & CONSTRUCTIONS

Size Inch (mm)	L (mm)	W (mm)	T (mm)/Symbol	Remark	M <sub>B</sub> (mm)
0402 (1005)	1.00±0.20	0.50±0.20	0.50±0.20 E	#	0.25 +0.05/-0.10
0603 (1608)	1.60±0.20	0.80±0.10	0.80±0.07 S		0.40±0.15
	1.60±0.30	0.80±0.30	0.80±0.30 X		
0805 (2012)	2.00±0.20	1.25±0.10	0.60±0.10 A		0.50±0.20
			0.80±0.10 B		
			1.25±0.10 D	#	
			1.25±0.30 I	#	
1206 (3216)	3.20+0.4/-0.1	1.60±0.15	0.80±0.10 B		0.60±0.20 (0.50±0.25)*
			0.95±0.10 C	#	
			1.15±0.15 J	#	
			1.25±0.10 D	#	
	3.20+0.4/-0.1	1.60±0.20	1.60±0.20 G	#	
	3.20±0.50	1.60±0.50	1.60±0.50 P	#	
1210 (3225)	3.20±0.40	2.50±0.20	0.95±0.10 C	#	0.75±0.25
			1.25±0.10 D	#	
	3.20±0.60	2.50±0.50	1.60±0.20 G	#	
			2.00±0.20 K	#	
			2.50±0.50 M	#	
1808 (4520)	4.50+0.6/-0.4	2.03±0.25	1.25±0.10 D	#	0.50±0.25
			2.00±0.20 K	#	
1812 (4532)	4.50+0.6/-0.4	3.20±0.30	1.25±0.10 D	#	0.75±0.25 (0.50±0.25)*
			1.60±0.20 G	#	
		3.20±0.40	2.50±0.50 M	#	
1825 (4563)	4.50+0.6/-0.4	6.30±0.40	2.00±0.20 (K)	#	0.75±0.35
2220 (5750)	5.70±0.50	5.00±0.40	2.50±0.30 (M)	#	0.85±0.35
2225 (5763)	5.70±0.50	6.30±0.40	2.80±0.30 (U)	#	0.85±0.35

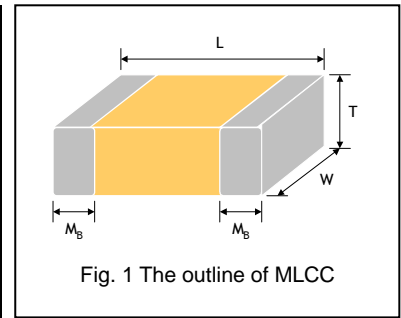

# Reflow soldering only is recommended.

\* For 1206 ≥ 1000V, 1812\_200V~4000V products.

6. GENERAL ELECTRICAL DATA

Dielectric	NP0	X7R	X5R
Size	0402, 0603, 0805, 1206, 1210, 1808, 1812, 1825, 2220, 2225		
Capacitance range*	0.1pF to 0.1μF	100pF to 47μF	0.033μF to 10μF
Capacitance tolerance**	Cap ≤ 5pF: B (±0.1pF), C (±0.25pF) 5pF < Cap < 10pF: C (±0.25pF), D (±0.5pF) Cap ≥ 10pF: F (±1%), G (±2%), J (±5%), K (±10%)		
Rated voltage (WVDC)	6.3V to 3000V		
Operating temperature	-55 to +125°C	-55 to +125°C	-55 to +85°C
Capacitance characteristic	±30ppm	±15%	±15%
Termination	Ni/Sn (lead-free termination)		

\* Measured at the condition of 30~70% related humidity.

NP0: Apply 1.0±0.2Vrms, 1.0MHz±10% for Cap≤1000pF and 1.0±0.2Vrms, 1.0kHz±10% for Cap>1000pF, 25°C at ambient temperature

X7R, X5R: Apply 1.0±0.2Vrms, 1.0kHz±10%, at 25°C ambient temperature.

\*\* Preconditioning for Class II MLCC: Perform a heat treatment at 150±10°C for 1 hour, then leave in a ambient condition for 24±2 hours before measurement.

Multilayer Ceramic Capacitors

**7. CAPACITANCE RANGE (NP0 Dielectric)**

**NP0 Dielectric 0402, 0603 Sizes**

DIELECTRIC		NP0											
SIZE		0402					0603						
RATED VOLTAGE (VDC)		10	16	25	50	100	10	16	25	50	100	200	250
Capacitance	0.1pF (0R1)	E	E	E	E								
	0.2pF (0R2)	E	E	E	E								
	0.3pF (0R3)	E	E	E	E		S	S	S	S			
	0.4pF (0R4)	E	E	E	E		S	S	S	S			
	0.5pF (0R5)	E	E	E	E	E	S	S	S	S	S	S	S
	0.6pF (0R6)	E	E	E	E	E	S	S	S	S	S	S	S
	0.7pF (0R7)	E	E	E	E	E	S	S	S	S	S	S	S
	0.8pF (0R8)	E	E	E	E	E	S	S	S	S	S	S	S
	0.9pF (0R9)	E	E	E	E	E	S	S	S	S	S	S	S
	1.0pF (1R0)	E	E	E	E	E	S	S	S	S	S	S	S
	1.2pF (1R2)	E	E	E	E	E	S	S	S	S	S	S	S
	1.5pF (1R5)	E	E	E	E	E	S	S	S	S	S	S	S
	1.8pF (1R8)	E	E	E	E	E	S	S	S	S	S	S	S
	2.2pF (2R2)	E	E	E	E	E	S	S	S	S	S	S	S
	2.7pF (2R7)	E	E	E	E	E	S	S	S	S	S	S	S
	3.3pF (3R3)	E	E	E	E	E	S	S	S	S	S	S	S
	3.9pF (3R9)	E	E	E	E	E	S	S	S	S	S	S	S
	4.7pF (4R7)	E	E	E	E	E	S	S	S	S	S	S	S
	5.6pF (5R6)	E	E	E	E	E	S	S	S	S	S	S	S
	6.8pF (6R8)	E	E	E	E	E	S	S	S	S	S	S	S
	8.2pF (8R2)	E	E	E	E	E	S	S	S	S	S	S	S
	10pF (100)	E	E	E	E	E	S	S	S	S	S	S	S
	12pF (120)	E	E	E	E	E	S	S	S	S	S	S	S
	15pF (150)	E	E	E	E	E	S	S	S	S	S	S	S
	18pF (180)	E	E	E	E	E	S	S	S	S	S	S	S
	22pF (220)	E	E	E	E	E	S	S	S	S	S	S	S
	27pF (270)	E	E	E	E	E	S	S	S	S	S	S	S
	33pF (330)	E	E	E	E	E	S	S	S	S	S	S	S
	39pF (390)	E	E	E	E	E	S	S	S	S	S	S	S
	47pF (470)	E	E	E	E	E	S	S	S	S	S	S	S
	56pF (560)	E	E	E	E	E	S	S	S	S	S	S	S
	68pF (680)	E	E	E	E	E	S	S	S	S	S	S	S
	82pF (820)	E	E	E	E	E	S	S	S	S	S	S	S
	100pF (101)	E	E	E	E	E	S	S	S	S	S	S	S
	120pF (121)	E	E	E	E	E	S	S	S	S	S	S	S
	150pF (151)	E	E	E	E	E	S	S	S	S	S	S	S
	180pF (181)	E	E	E	E	E	S	S	S	S	S	S	S
	220pF (221)	E	E	E	E	E	S	S	S	S	S	S	S
	270pF (271)	E	E	E	E	E	S	S	S	S	S	X	X
	330pF (331)	E	E	E	E	E	S	S	S	S	S	X	X
390pF (391)	E	E	E	E	E	S	S	S	S	S	X	X	
470pF (471)	E	E	E	E	E	S	S	S	S	S	X	X	
560pF (561)	E	E	E	E	E	S	S	S	S	S			
680pF (681)	E	E	E	E	E	S	S	S	S	S			
820pF (821)	E	E	E	E	E	S	S	S	S	S			
1,000pF (102)	E	E	E	E	E	S	S	S	S	S			
1,200pF (122)						X	X	X	X				
1,500pF (152)						X	X	X	X				
1,800pF (182)						X	X	X	X				
2,200pF (222)						X	X	X	X				
2,700pF (272)						X	X	X	X				
3,300pF (332)						X	X	X	X				
3,900pF (392)													
4,700pF (472)													
5,600pF (562)													
6,800pF (682)													
8,200pF (822)													
0.010uF (103)													
0.012uF (123)													

1. The letter in cell is expressed the symbol of product thickness.
2. For more information about products with special capacitance or other data, please contact WTC local representative.

Multilayer Ceramic Capacitors

Approval Sheet

NP0 Dielectric 0805 Size

DIELECTRIC		NP0									
SIZE		0805									
RATED VOLTAGE (VDC)		10	16	25	50	100	200	250	500	630	1000
Capacitance	0.5pF (0R5)	A	A	A	A	A	A	A	A	A	D
	0.6pF (0R6)	A	A	A	A	A	A	A	A	A	D
	0.7pF (0R7)	A	A	A	A	A	A	A	A	A	D
	0.8pF (0R8)	A	A	A	A	A	A	A	A	A	D
	0.9pF (0R9)	A	A	A	A	A	A	A	A	A	D
	1.0pF (1R0)	A	A	A	A	A	A	A	A	A	D
	1.2pF (1R2)	A	A	A	A	A	A	A	A	A	D
	1.5pF (1R5)	A	A	A	A	A	A	A	A	A	D
	1.8pF (1R8)	A	A	A	A	A	A	A	A	A	D
	2.2pF (2R2)	A	A	A	A	A	A	A	A	A	D
	2.7pF (2R7)	A	A	A	A	A	A	A	A	A	D
	3.3pF (3R3)	A	A	A	A	A	A	A	A	A	D
	3.9pF (3R9)	A	A	A	A	A	A	A	A	A	D
	4.7pF (4R7)	A	A	A	A	A	A	A	A	A	D
	5.6pF (5R6)	A	A	A	A	A	A	A	A	A	D
	6.8pF (6R8)	A	A	A	A	A	A	A	A	A	D
	8.2pF (8R2)	A	A	A	A	A	A	A	A	A	D
	10pF (100)	A	A	A	A	A	A	A	A	A	D
	12pF (120)	A	A	A	A	A	A	A	A	A	D
	15pF (150)	A	A	A	A	A	A	A	A	A	D
	18pF (180)	A	A	A	A	A	A	A	A	A	D
	22pF (220)	A	A	A	A	A	A	A	A	A	D
	27pF (270)	A	A	A	A	A	A	A	A	A	D
	33pF (330)	A	A	A	A	A	A	A	A	A	D
	39pF (390)	A	A	A	A	A	A	A	A	A	D
	47pF (470)	A	A	A	A	A	A	A	A	A	D
	56pF (560)	A	A	A	A	A	A	A	A	A	D
	68pF (680)	A	A	A	A	A	A	A	A	A	D
	82pF (820)	A	A	A	A	A	A	A	B	B	D
	100pF (101)	A	A	A	A	A	A	A	B	B	D
	120pF (121)	A	A	A	A	A	A	A	B	D	D
	150pF (151)	A	A	A	A	A	A	B	D	D	D
	180pF (181)	A	A	A	A	A	A	B	D	D	D
	220pF (221)	A	A	A	A	A	A	D	D	D	D
	270pF (271)	A	A	A	A	A	A	D	D	D	D
	330pF (331)	A	A	A	A	A	A	D	D	D	D
	390pF (391)	B	B	B	B	B	B	D	D	D	D
	470pF (471)	B	B	B	B	B	B	D	D	I	I
	560pF (561)	B	B	B	B	B	B	D	D	I	I
	680pF (681)	B	B	B	B	B	B	D	D	I	I
820pF (821)	B	B	B	B	B	B	D	D	I	I	
1,000pF (102)	B	B	B	B	B	B	D	D	I	I	
1,200pF (122)	B	B	B	B	B	B	D	D			
1,500pF (152)	B	B	B	B	B	B	D	D			
1,800pF (182)	B	B	B	B	B	B	D	D			
2,200pF (222)	B	B	B	B	B	B	D	D			
2,700pF (272)	D	D	D	D	D	D					
3,300pF (332)	D	D	D	D	D	D					
3,900pF (392)	D	D	D	D	D	D					
4,700pF (472)	D	D	D	D	D	D					
5,600pF (562)	D	D	D	D	D	D					
6,800pF (682)	D	D	D	D	D	D					
8,200pF (822)	D	D	D	D	D	D					
0.010μF (103)	D	D	D	D	D	D					

1. The letter in cell is expressed the symbol of product thickness.
2. For more information about products with special capacitance or other data, please contact WTC local representative.

Multilayer Ceramic Capacitors

**NP0 Dielectric 1206 Size**

DIELECTRIC		NP0											
SIZE		1206											
RATED VOLTAGE (VDC)		10	16	25	50	100	200	250	500	630	1000	1500	2000
Capacitance	1.0pF (1R0)												
	1.2pF (1R2)	B	B	B	B	B							
	1.5pF (1R5)	B	B	B	B	B	B	B	B	B	B	B	B
	1.8pF (1R8)	B	B	B	B	B	B	B	B	B	B	B	B
	2.2pF (2R2)	B	B	B	B	B	B	B	B	B	B	B	B
	2.7pF (2R7)	B	B	B	B	B	B	B	B	B	B	B	B
	3.3pF (3R3)	B	B	B	B	B	B	B	B	B	B	B	B
	3.9pF (3R9)	B	B	B	B	B	B	B	B	B	B	B	B
	4.7pF (4R7)	B	B	B	B	B	B	B	B	B	B	B	B
	5.6pF (5R6)	B	B	B	B	B	B	B	B	B	B	B	B
	6.8pF (6R8)	B	B	B	B	B	B	B	B	B	B	B	B
	8.2pF (8R2)	B	B	B	B	B	B	B	B	B	B	B	B
	10pF (100)	B	B	B	B	B	B	B	B	B	B	B	B
	12pF (120)	B	B	B	B	B	B	B	B	B	B	B	B
	15pF (150)	B	B	B	B	B	B	B	B	B	B	B	B
	18pF (180)	B	B	B	B	B	B	B	B	B	B	B	B
	22pF (220)	B	B	B	B	B	B	B	B	B	B	B	B
	27pF (270)	B	B	B	B	B	B	B	B	B	B	B	B
	33pF (330)	B	B	B	B	B	B	B	B	B	B	C	C
	39pF (390)	B	B	B	B	B	B	B	B	B	B	C	C
	47pF (470)	B	B	B	B	B	B	B	B	B	C	C	C
	56pF (560)	B	B	B	B	B	B	B	B	B	C	D	D
	68pF (680)	B	B	B	B	B	B	B	B	B	C	D	D
	82pF (820)	B	B	B	B	B	B	B	B	B	D	D	D
	100pF (101)	B	B	B	B	B	B	B	B	B	D	D	D
	120pF (121)	B	B	B	B	B	B	B	B	B	D	G	G
	150pF (151)	B	B	B	B	B	B	B	B	B	D	G	G
	180pF (181)	B	B	B	B	B	B	B	B	B	G	G	G
	220pF (221)	B	B	B	B	B	B	B	B	B	G	G	G
	270pF (271)	B	B	B	B	B	B	C	C	C	G	P	P
	330pF (331)	B	B	B	B	B	B	C	C	C	G	P	P
	390pF (391)	B	B	B	B	B	B	C	C	C	G	P	P
	470pF (471)	B	B	B	B	B	C	C	C	C	G		
	560pF (561)	B	B	B	B	B	C	D	D	D	G		
	680pF (681)	B	B	B	B	B	C	D	D	D	G		
	820pF (821)	B	B	B	B	B	C	G	G	G	G		
	1,000pF (102)	B	B	B	B	B	C	G	G	G	G		
	1,200pF (122)	B	B	B	B	B	C	G	G	G			
	1,500pF (152)	B	B	B	B	B	D	G	G	G			
	1,800pF (182)	B	B	B	B	B	D	G	G	G			
2,200pF (222)	B	B	B	B	B	D	G	G	G				
2,700pF (272)	B	B	B	B	B	D	G	G	G				
3,300pF (332)	B	B	B	B	B	D	G	G	G				
3,900pF (392)	B	B	B	B	B	D	G	G	G				
4,700pF (472)	B	B	B	B	B	D	G	G	G				
5,600pF (562)	B	B	B	B	B			G	G				
6,800pF (682)	C	C	C	C	C			G	G				
8,200pF (822)	D	D	D	D	D			G	G				
0.010μF (103)	D	D	D	D	D			G	G				
0.012μF (123)	P	P	P	P	P								
0.015μF (153)	P	P	P	P	P								
0.018μF (183)	P	P	P	P	P								
0.022μF (223)	P	P	P	P	P								
0.027μF (273)	P	P	P	P	P								
0.033μF (333)	P	P	P	P	P								
0.039μF (393)	P	P	P	P	P								

1. The letter in cell is expressed the symbol of product thickness.
2. For more information about products with special capacitance or other data, please contact WTC local representative.

Multilayer Ceramic Capacitors

Approval Sheet

NPO Dielectric 1210 Size

DIELECTRIC		NPO											
SIZE		1210											
RATED VOLTAGE (VDC)		10	16	25	50	100	200	250	500	630	1000	1500	2000
Capacitance	10pF (100)	C	C	C	C	C	C	C	C	C	C	C	C
	12pF (120)	C	C	C	C	C	C	C	C	C	C	C	C
	15pF (150)	C	C	C	C	C	C	C	C	C	C	C	C
	18pF (180)	C	C	C	C	C	C	C	C	C	C	C	C
	22pF (220)	C	C	C	C	C	C	C	C	C	C	C	C
	27pF (270)	C	C	C	C	C	C	C	C	C	C	C	C
	33pF (330)	C	C	C	C	C	C	C	C	C	C	C	C
	39pF (390)	C	C	C	C	C	C	C	C	C	C	C	C
	47pF (470)	C	C	C	C	C	C	C	C	C	C	C	C
	56pF (560)	C	C	C	C	C	C	C	C	C	C	D	D
	68pF (680)	C	C	C	C	C	C	C	C	C	C	D	D
	82pF (820)	C	C	C	C	C	C	C	C	C	C	D	D
	100pF (101)	C	C	C	C	C	C	C	C	C	D	D	D
	120pF (121)	C	C	C	C	C	C	C	C	C	D	D	D
	150pF (151)	C	C	C	C	C	C	C	C	C	D	G	G
	180pF (181)	C	C	C	C	C	C	C	C	C	D	G	G
	220pF (221)	C	C	C	C	C	C	C	C	C	G	G	G
	270pF (271)	C	C	C	C	C	C	C	C	C	G	K	K
	330pF (331)	C	C	C	C	C	C	C	C	C	G	K	K
	390pF (391)	C	C	C	C	C	C	C	C	C	G	M	M
	470pF (471)	C	C	C	C	C	C	C	C	C	G	M	M
	560pF (561)	C	C	C	C	C	C	C	C	C	G		
	680pF (681)	C	C	C	C	C	C	C	C	C	G		
	820pF (821)	C	C	C	C	C	C	C	C	C	G		
	1,000pF (102)	C	C	C	C	C	D	D	D	D	G		
	1,200pF (122)	C	C	C	C	C	D	D	D	D	G		
	1,500pF (152)	C	C	C	C	C	D	D	D	D	K		
	1,800pF (182)	C	C	C	C	C	D	D	D	D	M		
	2,200pF (222)	C	C	C	C	C	D	D	D	D	M		
	2,700pF (272)	C	C	C	C	C	D	D	D	D	M		
	3,300pF (332)	C	C	C	C	C	D	D	D	D	M		
	3,900pF (392)	C	C	C	C	C	D	D	D	D	M		
	4,700pF (472)	C	C	C	C	C	G	G	G	G	M		
	5,600pF (562)	C	C	C	C	C	G	G	G	G	M		
	6,800pF (682)	C	C	C	C	C	G	G	G	G	M		
	8,200pF (822)	C	C	C	C	C	G	G	G	G	M		
	0.010μF (103)	C	C	C	C	C	G	G	K	K	M		
	0.012μF (123)	D	D	D	D	D	K	K	K	K	M		
	0.015μF (153)	D	D	D	D	D	K	K	K	K	M		
	0.018μF (183)	K	K	K	K	K	K	K	K	K	M		
0.022μF (223)	K	K	K	K	K	K	K	K	K	M			
0.027μF (273)	K	K	K	K	K	K	K	M	M				
0.033μF (333)	K	K	K	K	K	K	K	M	M				
0.039μF (393)	K	K	K	K	K	K	K						
0.047μF (473)	K	K	K	K	K	K	K						

1. The letter in cell is expressed the symbol of product thickness.
2. For more information about products with special capacitance or other data, please contact WTC local representative.

Multilayer Ceramic Capacitors

**NP0 Dielectric 1808 Size**

DIELECTRIC		NP0					
SIZE		1808					
RATED VOLTAGE (VDC)		500	630	1000	1500	2000	3000
Capacitance	2.0pF (2R0)						
	2.2pF (2R2)	D	D	D	D	D	D
	2.7pF (2R7)	D	D	D	D	D	D
	3.3pF (3R3)	D	D	D	D	D	D
	3.9pF (3R9)	D	D	D	D	D	D
	4.7pF (4R7)	D	D	D	D	D	D
	5.6pF (5R6)	D	D	D	D	D	D
	6.8pF (6R8)	D	D	D	D	D	D
	8.2pF (8R2)	D	D	D	D	D	D
	10pF (100)	D	D	D	D	D	D
	12pF (120)	D	D	D	D	D	D
	15pF (150)	D	D	D	D	D	D
	18pF (180)	D	D	D	D	D	D
	22pF (220)	D	D	D	D	D	D
	27pF (270)	D	D	D	D	D	D
	33pF (330)	D	D	D	D	D	D
	39pF (390)	D	D	D	D	D	D
	47pF (470)	D	D	D	D	D	D
	56pF (560)	D	D	D	D	D	D
	68pF (680)	D	D	D	D	D	D
	82pF (820)	D	D	D	D	D	D
	100pF (101)	D	D	D	D	D	K
	120pF (121)	D	D	D	D	D	K
	150pF (151)	D	D	D	K	K	K
	180pF (181)	D	D	D	K	K	K
	220pF (221)	D	D	D	K	K	K
	270pF (271)	K	K	K	K	K	K
	330pF (331)	K	K	K	K	K	K
	390pF (391)	K	K	K	K	K	K
	470pF (471)	K	K	K	K	K	
	560pF (561)	K	K	K	K	K	
	680pF (681)	K	K	K	K	K	
	820pF (821)	K	K	K	D	D	
1,000pF (102)	K	K	K	G	G		
1,200pF (122)	K	K	G				
1,500pF (152)	K	K	G				
1,800pF (182)	K	K	K				
2,200pF (222)	K	K	K				
2,700pF (272)	K	K					
3,300pF (332)	K	K					
3,900pF (392)							

1. The letter in cell is expressed the symbol of product thickness.
2. For more information about products with special capacitance or other data, please contact WTC local representative.



Multilayer Ceramic Capacitors

**NP0 Dielectric 1812 Size**

DIELECTRIC		NP0												
SIZE		1812												
RATED VOLTAGE (VDC)		10	16	25	50	100	200	250	500	630	1000	1500	2000	3000
Capacitance	10pF (100)	D	D	D	D	D	D	D	D	D	D	D	D	D
	12pF (120)	D	D	D	D	D	D	D	D	D	D	D	D	D
	15pF (150)	D	D	D	D	D	D	D	D	D	D	D	D	D
	18pF (180)	D	D	D	D	D	D	D	D	D	D	D	D	D
	22pF (220)	D	D	D	D	D	D	D	D	D	D	D	D	D
	27pF (270)	D	D	D	D	D	D	D	D	D	D	D	D	D
	33pF (330)	D	D	D	D	D	D	D	D	D	D	D	D	D
	39pF (390)	D	D	D	D	D	D	D	D	D	D	D	D	D
	47pF (470)	D	D	D	D	D	D	D	D	D	D	D	D	D
	56pF (560)	D	D	D	D	D	D	D	D	D	D	D	D	D
	68pF (680)	D	D	D	D	D	D	D	D	D	D	D	D	D
	82pF (820)	D	D	D	D	D	D	D	D	D	D	D	D	D
	100pF (101)	D	D	D	D	D	D	D	D	D	D	D	D	D
	120pF (121)	D	D	D	D	D	D	D	D	D	D	D	D	D
	150pF (151)	D	D	D	D	D	D	D	D	D	D	D	D	D
	180pF (181)	D	D	D	D	D	D	D	D	D	D	D	D	K
	220pF (221)	D	D	D	D	D	D	D	D	D	D	D	D	K
	270pF (271)	D	D	D	D	D	D	D	D	D	D	K	K	K
	330pF (331)	D	D	D	D	D	D	D	D	D	D	K	K	K
	390pF (391)	D	D	D	D	D	D	D	D	D	D	K	K	K
	470pF (471)	D	D	D	D	D	D	D	D	D	K	K	K	K
	560pF (561)	D	D	D	D	D	D	D	D	D	K	K	K	
	680pF (681)	D	D	D	D	D	D	D	D	D	K	K	K	
	820pF (821)	D	D	D	D	D	D	D	D	D	K	K	K	
	1,000pF (102)	D	D	D	D	D	D	D	D	D	K	K	K	
	1,200pF (122)	D	D	D	D	D	D	D	D	D	K			
	1,500pF (152)	D	D	D	D	D	D	D	D	D	K			
	1,800pF (182)	D	D	D	D	D	D	D	D	D	K			
	2,200pF (222)	D	D	D	D	D	D	D	D	D	K			
	2,700pF (272)	D	D	D	D	D	D	D	D	D	K			
	3,300pF (332)	D	D	D	D	D	D	D	D	D	K			
	3,900pF (392)	D	D	D	D	D	D	D	D	D	M			
	4,700pF (472)	D	D	D	D	D	D	D	D	D	M			
	5,600pF (562)	D	D	D	D	D	D	D	D	D	M			
	6,800pF (682)	D	D	D	D	D	D	D	D	D				
	8,200pF (822)	D	D	D	D	D	D	D	D	D				
	0.010μF (103)	D	D	D	D	D	D	D	D	D				
	0.012μF (123)	D	D	D	D	D	D	D	G	G				
	0.015μF (153)	D	D	D	D	D	D	D	G	G				
	0.018μF (183)	D	D	D	D	D	D	D	K	K				
0.022μF (223)	D	D	D	D	D	D	D	K	K					
0.027μF (273)	D	D	D	D	D	D	D							
0.033μF (333)	D	D	D	D	D	D	D							
0.039μF (393)														
0.047μF (473)														

1. The letter in cell is expressed the symbol of product thickness.
2. For more information about products with special capacitance or other data, please contact WTC local representative.

Multilayer Ceramic Capacitors

**NP0 Dielectric 1825 to 2225 Sizes**

DIELECTRIC	NP0																					
	SIZE	1825						2220						2225								
	RATED VOLTAGE (VDC)	100	200 250	500 630	1000	2000	3000	100	200 250	500	630	1000	2000	3000	100	200 250	500	630	1000	2000	3000	
Capacitance	10pF (100)	K	K	K	K	K	K	K	K	K	K	K	K	K	K	K	K	K	K	K	K	
	12pF (120)	K	K	K	K	K	K	K	K	K	K	K	K	K	K	K	K	K	K	K	K	K
	15pF (150)	K	K	K	K	K	K	K	K	K	K	K	K	K	K	K	K	K	K	K	K	K
	18pF (180)	K	K	K	K	K	K	K	K	K	K	K	K	K	K	K	K	K	K	K	K	K
	22pF (220)	K	K	K	K	K	K	K	K	K	K	K	K	K	K	K	K	K	K	K	K	K
	27pF (270)	K	K	K	K	K	K	K	K	K	K	K	K	K	K	K	K	K	K	K	K	K
	33pF (330)	K	K	K	K	K	K	K	K	K	K	K	K	K	K	K	K	K	K	K	K	K
	39pF (390)	K	K	K	K	K	K	K	K	K	K	K	K	K	K	K	K	K	K	K	K	K
	47pF (470)	K	K	K	K	K	K	K	K	K	K	K	K	K	K	K	K	K	K	K	K	K
	56pF (560)	K	K	K	K	K	K	K	K	K	K	K	K	K	K	K	K	K	K	K	K	K
	68pF (680)	K	K	K	K	K	K	K	K	K	K	K	K	K	K	K	K	K	K	K	K	K
	82pF (820)	K	K	K	K	K	K	K	K	K	K	K	K	K	K	K	K	K	K	K	K	K
	100pF (101)	K	K	K	K	K	K	K	K	K	K	K	K	K	K	K	K	K	K	K	K	K
	120pF (121)	K	K	K	K	K	K	K	K	K	K	K	K	K	K	K	K	K	K	K	K	K
	150pF (151)	K	K	K	K	K	K	K	K	K	K	K	K	K	K	K	K	K	K	K	K	K
	180pF (181)	K	K	K	K	K	K	K	K	K	K	K	K	K	K	K	K	K	K	K	K	K
	220pF (221)	K	K	K	K	K	K	K	K	K	K	K	K	K	K	K	K	K	K	K	K	K
	270pF (271)	K	K	K	K	K	K	K	K	K	K	K	K	K	K	K	K	K	K	K	K	K
	330pF (331)	K	K	K	K	K	K	K	K	K	K	K	K	K	M	K	K	K	K	K	K	K
	390pF (391)	K	K	K	K	K	K	K	K	K	K	K	K	M	K	K	K	K	K	K	K	K
	470pF (471)	K	K	K	K	K	K	K	K	K	K	K	M	K	K	K	K	K	K	K	K	K
	560pF (561)	K	K	K	K	K	K	K	K	K	K	M	K	K	K	K	K	K	K	K	K	K
	680pF (681)	K	K	K	K	K	M	K	K	K	K	M	K	K	K	K	K	K	K	K	K	K
	820pF (821)	K	K	K	K	K	M	K	K	K	K	M	K	K	K	K	K	K	K	M	M	M
	1,000pF (102)	K	K	K	K	K	M	K	K	K	K	M	K	K	K	K	K	K	K	M	M	M
	1,200pF (122)	K	K	K	K	K		K	K	K	K	M	M	M	K	K	K	K	K	M		
	1,500pF (152)	K	K	K	K	M		K	K	K	K	M	M	M	K	K	K	K	K	M		
	1,800pF (182)	K	K	K	K	M		K	K	K	K	M	M		K	K	K	K	K	M		
	2,200pF (222)	K	K	K	K	M		K	K	K	K	M	M		K	K	K	K	K	M		
	2,700pF (272)	K	K	K	K	M		K	K	K	K	M	M		K	K	K	K	K	M		
	3,300pF (332)	K	K	K	K	M		K	K	K	K	M	M		K	K	K	K	K	M		
	3,900pF (392)	K	K	K	M	M		K	K	K	K	M	M		K	K	K	K	K	M		
	4,700pF (472)	K	K	K	M	M		K	K	K	K	M	M		K	K	K	K	K	M		
5,600pF (562)	K	K	K	M			K	K	K	K	M			K	K	K	K	M	M			
6,800pF (682)	K	K	K	M			K	K	K	K	M			K	K	K	K	M	M			
8,200pF (822)	K	K	K	M			K	K	K	K	M			K	K	K	K	M	M			
0.010uF (103)	K	K	K	M			K	K	K	K	M			K	K	K	K	M	M			
0.012uF (123)	K	K	K				K	K	K	K				K	K	K	K					
0.015uF (153)	K	K	K				K	K	K	K				K	K	K	K					
0.018uF (183)	K	K	K				K	K	K	K				K	K	K	K					
0.022uF (223)	K	K	K				K	K	K	K				K	K	K	K					
0.027uF (273)	K	K	K				K	K	K					K	K	K	K					
0.033uF (333)	K	K	K				K	K	K					K	K	K	K					
0.039uF (393)	K	K	M				K	K	M					K	K	K	K					
0.047uF (473)	K	K					K	M	M					K	K	K	K					
0.056uF (563)	K	M					K	M						K	M	M	M					
0.068uF (683)	K	M					K	M						K	M	M	M					
0.082uF (823)	M						M							K	M	M						
0.1uF (104)	M						M							M	M							
0.12uF (124)																						
0.15uF (154)																						
0.18uF (184)																						
0.22uF (224)																						
0.27uF (274)																						

1. The letter in cell is expressed the symbol of product thickness.
2. For more information about products with special capacitance or other data, please contact WTC local representative.

Multilayer Ceramic Capacitors

**7-1. CAPACITANCE RANGE (X7R Dielectric)**

**0402, 0603 Sizes**

DIELECTRIC		X7R											
SIZE		0402					0603						
RATED VOLTAGE (VDC)		10	16	25	50	100	10	16	25	50	100	200	250
Capacitance	100pF (101)	E	E	E	E	E	S	S	S	S	S	X	X
	120pF (121)	E	E	E	E	E	S	S	S	S	S	X	X
	150pF (151)	E	E	E	E	E	S	S	S	S	S	X	X
	180pF (181)	E	E	E	E	E	S	S	S	S	S	X	X
	220pF (221)	E	E	E	E	E	S	S	S	S	S	X	X
	270pF (271)	E	E	E	E	E	S	S	S	S	S	X	X
	330pF (331)	E	E	E	E	E	S	S	S	S	S	X	X
	390pF (391)	E	E	E	E	E	S	S	S	S	S	X	X
	470pF (471)	E	E	E	E	E	S	S	S	S	S	X	X
	560pF (561)	E	E	E	E	E	S	S	S	S	S	X	X
	680pF (681)	E	E	E	E	E	S	S	S	S	S	X	X
	820pF (821)	E	E	E	E	E	S	S	S	S	S	X	X
	1,000pF (102)	E	E	E	E	E	S	S	S	S	S	X	X
	1,200pF (122)	E	E	E	E	E	S	S	S	S	S	X	X
	1,500pF (152)	E	E	E	E	E	S	S	S	S	S	X	X
	1,800pF (182)	E	E	E	E	E	S	S	S	S	S	X	X
	2,200pF (222)	E	E	E	E	E	S	S	S	S	S	X	X
	2,700pF (272)	E	E	E	E	E	S	S	S	S	S	X	X
	3,300pF (332)	E	E	E	E	E	S	S	S	S	S	X	X
	3,900pF (392)	E	E	E	E	E	S	S	S	S	S	X	X
	4,700pF (472)	E	E	E	E	E	S	S	S	S	S	X	X
	5,600pF (562)	E	E	E	E	E	S	S	S	S	S	X	X
	6,800pF (682)	E	E	E	E	E	S	S	S	S	S	X	X
	8,200pF (822)	E	E	E	E	E	S	S	S	S	S	X	X
	0.010μF (103)	E	E	E	E	E	S	S	S	S	S	X	X
	0.012μF (123)	E	E	E	E	E	S	S	S	S	S	X	
	0.015μF (153)	E	E	E	E	E	S	S	S	S	S	X	
	0.018μF (183)	E	E	E	E	E	S	S	S	S	S	X	
	0.022μF (223)	E	E	E	E	E	S	S	S	S	S	X	
	0.027μF (273)	E	E	E	E	E	S	S	S	S	S	X	
	0.033μF (333)	E	E	E	E	E	S	S	S	X	X		
	0.039μF (393)	E	E	E	E	E	S	S	S	X	X		
	0.047μF (473)	E	E	E	E	E	S	S	S	X	X		
	0.056μF (563)	E	E	E	E	E	S	S	S	X	X		
	0.068μF (683)	E	E	E	E	E	S	S	S	X	X		
	0.082μF (823)	E	E	E	E	E	S	S	S	X	X		
	0.10μF (104)	E	E	E	E	E	S	S	S	X	X		
	0.12μF (124)						S	S	X				
	0.15μF (154)						S	S	X				
	0.18μF (184)						S	S	X				
	0.22μF (224)						S	S	X	X			
	0.27μF (274)						X	X	X				
	0.33μF (334)						X	X	X				
	0.39μF (394)						X	X	X				
	0.47μF (474)						X	X	X				
	0.56μF (564)						X	X					
	0.68μF (684)						X	X					
0.82μF (824)						X	X						
1.0μF (105)						X	X	X					
1.5μF (155)													
2.2μF (225)													
4.7μF (475)													

1. The letter in cell is expressed the symbol of product thickness.
2. For more information about products with special capacitance or other data, please contact WTC local representative.

X7R Dielectric 0805 Size

DIELECTRIC		X7R										
SIZE		0805										
RATED VOLTAGE (VDC)		10	16	25	50	100	200	250	500	630	1000	
Capacitance	100pF (101)	D	D	D	D	D	D	D	B	B	B	
	120pF (121)	D	D	D	D	D	D	D	B	B	B	
	150pF (151)	D	D	D	D	D	D	D	B	B	B	
	180pF (181)	D	D	D	D	D	D	D	B	B	B	
	220pF (221)	D	D	D	D	D	D	D	B	B	B	
	270pF (271)	D	D	D	D	D	D	D	B	B	B	
	330pF (331)	D	D	D	D	D	D	D	B	B	B	
	390pF (391)	D	D	D	D	D	D	D	B	B	B	
	470pF (471)	D	D	D	D	D	D	D	B	B	B	
	560pF (561)	D	D	D	D	D	D	D	B	B	B	
	680pF (681)	D	D	D	D	D	D	D	B	B	B	
	820pF (821)	D	D	D	D	D	D	D	B	B	B	
	1,000pF (102)	D	D	D	D	D	D	D	B	B	B	
	1,200pF (122)	D	D	D	D	D	D	D	D	B	B	B
	1,500pF (152)	D	D	D	D	D	D	D	D	B	B	D
	1,800pF (182)	D	D	D	D	D	D	D	D	B	B	D
	2,200pF (222)	D	D	D	D	D	D	D	D	B	B	D
	2,700pF (272)	D	D	D	D	D	D	D	D	B	B	
	3,300pF (332)	D	D	D	D	D	D	D	D	B	B	
	3,900pF (392)	D	D	D	D	D	D	D	D	B	B	
	4,700pF (472)	D	D	D	D	D	D	D	D	D	D	
	5,600pF (562)	D	D	D	D	D	D	D	D	D	D	
	6,800pF (682)	D	D	D	D	D	D	D	D	D	D	
	8,200pF (822)	D	D	D	D	D	D	D	D	D	D	
	0.010μF (103)	D	D	D	D	D	D	D	D	D	D	
	0.012μF (123)	D	D	D	D	D	D	D	D	D	D	
	0.015μF (153)	D	D	D	D	D	D	D	D	D	D	
	0.018μF (183)	D	D	D	D	D	D	D	D	D	D	
	0.022μF (223)	D	D	D	D	D	D	D	D	D	D	
	0.027μF (273)	D	D	D	D	D	D	D	D	D	D	
	0.033μF (333)	D	D	D	D	D	D	D	D	D		
	0.039μF (393)	D	D	D	D	D	D	D	D			
	0.047μF (473)	D	D	D	D	D	D	D	D			
	0.056μF (563)	D	D	D	D	D	D	D	D			
	0.068μF (683)	D	D	D	D	D	D	D	D			
	0.082μF (823)	D	D	D	D	D	D	D	D			
	0.10μF (104)	D	D	D	D	D	D	D				
	0.12μF (124)	D	D	D	D	D	I					
	0.15μF (154)	D	D	D	D	D	I					
	0.18μF (184)	D	D	D	D	D	I					
0.22μF (224)	D	D	D	D	D	I						
0.27μF (274)	I	I	I	I	I							
0.33μF (334)	I	I	I	I	I							
0.39μF (394)	I	I	I	I	I							
0.47μF (474)	I	I	I	I	I							
0.56μF (564)	I	I	I	I	I							
0.68μF (684)	I	I	I	I	I							
0.82μF (824)	I	I	I	I	I							
1.0μF (105)	I	I	I	I	I							
1.5μF (155)	I	I	I	I	I							
2.2μF (225)	I	I	I	I	I							
4.7μF (475)	I	I	I	I	I							
10μF (106)	I	I	I	I	I							

1. The letter in cell is expressed the symbol of product thickness.
2. For more information about products with special capacitance or other data, please contact WTC local representative.

X7R Dielectric 1206 Size

DIELECTRIC		X7R														
SIZE		1206														
RATED VOLTAGE (VDC)		10	16	25	35	50	100	200	250	400	450	500	630	1000	1500	2000
Capacitance	100pF (101)							D	D			D	D	D	D	D
	120pF (121)							D	D			D	D	D	D	D
	150pF (151)	D	D	D		D	D	D	D			D	D	D	D	D
	180pF (181)	D	D	D		D	D	D	D			D	D	D	D	D
	220pF (221)	D	D	D		D	D	D	D			D	D	D	D	D
	270pF (271)	D	D	D		D	D	D	D			D	D	D	D	D
	330pF (331)	D	D	D		D	D	D	D			D	D	D	D	D
	390pF (391)	D	D	D		D	D	D	D			D	D	D	D	D
	470pF (471)	D	D	D		D	D	D	D			D	D	D	D	D
	560pF (561)	D	D	D		D	D	D	D			D	D	D	D	D
	680pF (681)	D	D	D		D	D	D	D			D	D	D	D	D
	820pF (821)	D	D	D		D	D	D	D			D	D	D	D	D
	1,000pF (102)	D	D	D		D	D	D	D			D	D	D	D	D
	1,200pF (122)	D	D	D		D	D	D	D			D	D	D	G	G
	1,500pF (152)	D	D	D		D	D	D	D			D	D	D	G	G
	1,800pF (182)	D	D	D		D	D	D	D			D	D	D	G	G
	2,200pF (222)	D	D	D		D	D	D	D			D	D	D	G	G
	2,700pF (272)	D	D	D		D	D	D	D			D	D	D	G	G
	3,300pF (332)	D	D	D		D	D	D	D			D	D	D	G	G
	3,900pF (392)	D	D	D		D	D	D	D			D	D	D	G	
	4,700pF (472)	D	D	D		D	D	D	D			D	D	D	G	
	5,600pF (562)	D	D	D		D	D	D	D			D	D	D	G	
	6,800pF (682)	D	D	D		D	D	D	D			D	D	D	G	
	8,200pF (822)	D	D	D		D	D	D	D			D	D	D	G	
	0.010μF (103)	D	D	D		D	D	D	D			D	D	D	G	
	0.012μF (123)	D	D	D		D	D	D	D			D	D	G		
	0.015μF (153)	D	D	D		D	D	D	D			D	D	G		
	0.018μF (183)	D	D	D		D	D	D	D			D	D			
	0.022μF (223)	D	D	D		D	D	D	D			G	G			
	0.027μF (273)	D	D	D		D	D	D	D			G	G			
	0.033μF (333)	D	D	D		D	D	G	G			G	G			
	0.039μF (393)	D	D	D		D	D	G	G			G	G			
	0.047μF (473)	D	D	D		D	D	G	G			G	G			
	0.056μF (563)	D	D	D		D	D	G	G			G	G			
	0.068μF (683)	D	D	D		D	D	G	G	G	G					
	0.082μF (823)	D	D	D		D	D	G	G	G	G					
	0.10μF (104)	D	D	D		D	D	G	G	G	G					
	0.12μF (124)	D	D	D		D	D									
	0.15μF (154)	C	C	C		C	G									
	0.18μF (184)	C	C	C		C	G									
	0.22μF (224)	C	C	C		C	G	G	G							
	0.27μF (274)	C	C	C		D	G									
	0.33μF (334)	C	C	C		D	G									
	0.39μF (394)	C	C	J		P	G									
	0.47μF (474)	J	J	J		P	G									
	0.56μF (564)	J	J	J		P	P									
	0.68μF (684)	J	J	J		P	P									
0.82μF (824)	J	J	J		P	P										
1.0μF (105)	J	J	J		P	P										
1.5μF (155)	J	J	P		P	P										
2.2μF (225)	J	J	P		P	P										
3.3μF (335)	P	P	P		P											
4.7μF (475)	P	P	P		P											
10μF (106)	P	P	P	P												
22μF (226)	P															
47μF (476)																

1. The letter in cell is expressed the symbol of product thickness.  
2. For more information about products with special capacitance or other data, please contact WTC local representative.

Multilayer Ceramic Capacitors

X7R Dielectric 1210 Size

DIELECTRIC		X7R															
SIZE		1210															
RATED VOLTAGE (VDC)		6.3	10	16	25	50	100	200	250	400	450	500	630	1000	1500	2000	
Capacitance	100pF (101)											D	D	D	D	D	
	120pF (121)											D	D	D	D	D	
	150pF (151)											D	D	D	D	D	
	180pF (181)											D	D	D	D	D	
	220pF (221)											D	D	D	D	D	
	270pF (271)											D	D	D	D	D	
	330pF (331)											D	D	D	D	D	
	390pF (391)											D	D	D	D	D	
	470pF (471)											D	D	D	D	D	
	560pF (561)											D	D	D	D	D	
	680pF (681)											D	D	D	D	D	
	820pF (821)											D	D	D	D	D	
	1,000pF (102)			C	C	C	C	C	C	C			D	D	D	D	D
	1,200pF (122)			C	C	C	C	C	C	C			D	D	D	M	M
	1,500pF (152)			C	C	C	C	C	C	C			D	D	D	M	M
	1,800pF (182)			C	C	C	C	C	C	C			D	D	D	M	M
	2,200pF (222)			C	C	C	C	C	C	C			D	D	D	M	M
	2,700pF (272)			C	C	C	C	C	C	C			D	D	D	M	M
	3,300pF (332)			C	C	C	C	C	C	C			D	D	D	M	M
	3,900pF (392)			C	C	C	C	C	C	C			D	D	G	M	M
	4,700pF (472)			C	C	C	C	C	C	C			D	D	G	M	M
	5,600pF (562)			C	C	C	C	C	C	C			D	D	G	M	M
	6,800pF (682)			C	C	C	C	C	C	C			D	D	G	M	M
	8,200pF (822)			C	C	C	C	C	C	C			D	D	G	M	M
	0.010μF (103)			C	C	C	C	C	C	C			D	D	G	M	M
	0.012μF (123)			C	C	C	C	C	C	C			D	D	G		
	0.015μF (153)			C	C	C	C	C	C	C			D	D	G		
	0.018μF (183)			C	C	C	C	C	C	C			D	D	G		
	0.022μF (223)			C	C	C	C	C	C	C			D	D	G		
	0.027μF (273)			C	C	C	C	C	C	C			G	G	G		
	0.033μF (333)			C	C	C	C	C	C	C			G	G	G		
	0.039μF (393)			C	C	C	C	C	C	C			G	G	K		
	0.047μF (473)			C	C	C	C	C	D	D			G	G	M		
	0.056μF (563)			C	C	C	C	C	D	D			G	G			
	0.068μF (683)			C	C	C	C	C	G	G			K	K			
	0.082μF (823)			C	C	C	C	C	G	G			K	K			
	0.10μF (104)			C	C	C	C	C	G	G			K	K			
	0.12μF (124)			C	C	C	C	C	G	G	M	M	M	M			
	0.15μF (154)			C	C	C	C	D	M	M	M	M	M	M			
	0.18μF (184)			C	C	C	C	D	M	M	M	M					
	0.22μF (224)			C	C	C	C	D	M	M	M	M					
	0.27μF (274)			C	C	C	C	G	M	M	M	M					
	0.33μF (334)			C	C	C	D	G	M	M	M	M					
	0.39μF (394)			C	C	C	D	M	M	M							
	0.47μF (474)			C	C	C	D	M	M	M							
	0.56μF (564)			D	D	D	D	M	M	M							
	0.68μF (684)			D	D	D	D	K	M	M							
0.82μF (824)			D	D	D	D	K										
1.0μF (105)			D	D	D	D	K										
1.5μF (155)				K	G	M	M										
2.2μF (225)				K	G	M	M										
3.3μF (335)				K	G	M											
4.7μF (475)			K	K	K	M	M										
10μF (106)			K	K	M	M											
22μF (226)				M													
47μF (476)		M															

1. The letter in cell is expressed the symbol of product thickness.  
2. For more information about products with special capacitance or other data, please contact WTC local representative.

X7R Dielectric 1808, 1812 Sizes

DIELECTRIC		X7R																				
SIZE		1808						1812														
RATED VOLTAGE (VDC)		500	630	1000	1500	2000	3000	10	16	25	50	100	200	250	500	630	1000	1500	2000	3000		
Capacitance	100pF (101)																					
	120pF (121)																					
	150pF (151)	D	D	D	D	D	D															
	180pF (181)	D	D	D	D	D	D															
	220pF (221)	D	D	D	D	D	D															
	270pF (271)	D	D	D	D	D	D						D	D	D	D	D	D	D	D	K	
	330pF (331)	D	D	D	D	D	K						D	D	D	D	D	D	D	D	K	
	390pF (391)	D	D	D	D	D	K						D	D	D	D	D	D	D	D	K	
	470pF (471)	D	D	D	D	D	K						D	D	D	D	D	D	D	D	K	
	560pF (561)	D	D	D	D	D	K						D	D	D	D	D	D	D	D	K	
	680pF (681)	D	D	D	D	D	K						D	D	D	D	D	D	D	D	K	
	820pF (821)	D	D	D	D	D	K						D	D	D	D	D	D	D	D	K	
	1,000pF (102)	D	D	D	K	K	K	D	D	D	D	D	D	D	D	D	D	D	D	D	K	
	1,200pF (122)	D	D	D	K	K	K	D	D	D	D	D	D	D	D	D	D	D	D	D	K	
	1,500pF (152)	D	D	D	K	K	K	D	D	D	D	D	D	D	D	D	D	D	D	D	K	
	1,800pF (182)	D	D	D	K	K	K	D	D	D	D	D	D	D	D	D	D	D	D	G	G	M
	2,200pF (222)	D	D	D	K	K		D	D	D	D	D	D	D	D	D	D	D	D	G	G	M
	2,700pF (272)	D	D	D	K	K		D	D	D	D	D	D	D	D	D	D	D	D	G	G	M
	3,300pF (332)	D	D	D	K	K		D	D	D	D	D	D	D	D	D	D	D	D	K	K	M
	3,900pF (392)	D	D	D	K	K		D	D	D	D	D	D	D	D	D	D	D	D	K	K	M
	4,700pF (472)	D	D	D	K	K		D	D	D	D	D	D	D	D	D	D	D	D	K	K	M
	5,600pF (562)	K	K	K	K	K		D	D	D	D	D	D	D	D	D	D	D	D	M	M	M
	6,800pF (682)	K	K	K	K	K		D	D	D	D	D	D	D	D	D	D	D	D	M	M	M
	8,200pF (822)	K	K	K				D	D	D	D	D	D	D	D	D	D	D	D	M	M	
	0.010μF (103)	K	K	K				D	D	D	D	D	D	D	D	D	D	D	D	M	M	
	0.012μF (123)	K	K	K				D	D	D	D	D	D	D	D	D	D	D	D	K		
	0.015μF (153)	K	K	K				D	D	D	D	D	D	D	D	D	D	D	D	K		
	0.018μF (183)	K	K	K				D	D	D	D	D	D	D	D	D	D	D	D	M		
	0.022μF (223)	K	K	K				D	D	D	D	D	D	D	D	D	D	D	D	M		
	0.027μF (273)	K	K	K				D	D	D	D	D	D	D	D	D	D	D	D	M		
	0.033μF (333)	K	K	K				D	D	D	D	D	D	D	D	D	D	D	D	M		
	0.039μF (393)	K	K	K				D	D	D	D	D	D	D	D	D	D	D	D	M		
	0.047μF (473)	K	K	K				D	D	D	D	D	D	D	D	D	D	D	D	M		
	0.056μF (563)	K	K	K				D	D	D	D	D	D	D	D	D	K	K	M			
	0.068μF (683)	K	K					D	D	D	D	D	D	D	D	K	K	M				
	0.082μF (823)	K	K					D	D	D	D	D	D	D	D	K	K	M				
	0.10μF (104)							D	D	D	D	D	D	D	D	K	K	M				
	0.12μF (124)							D	D	D	D	D	D	D	D	M	M					
	0.15μF (154)							D	D	D	D	D	D	D	K	K	M	M				
	0.18μF (184)							D	D	D	D	D	D	D	K	K	M	M				
	0.22μF (224)							D	D	D	D	D	D	D	K	K	M	M				
	0.27μF (274)							D	D	D	D	D	D	D	K	K	M					
	0.33μF (334)							D	D	D	D	D	D	D	K	K	M					
	0.39μF (394)							D	D	D	D	D	D	D	K	K	M					
	0.47μF (474)							D	D	D	D	D	D	D	K	K	K	M				
	0.56μF (564)							D	D	D	D	D	D	D	K	M	M					
	0.68μF (684)							D	D	D	D	D	D	D	K	M	M					
0.82μF (824)							D	D	D	D	D	D	D	K	M	M						
1.0μF (105)							D	D	D	D	D	D	D	K	M	M						
1.5μF (155)														K								
2.2μF (225)														M	M							
3.3μF (335)																						
4.7μF (475)																						

1. The letter in cell is expressed the symbol of product thickness.  
2. For more information about products with special capacitance or other data, please contact WTC local representative.

Multilayer Ceramic Capacitors

X7R Dielectric 1825 to 2225 Sizes

DIELECTRIC	X7R																					
	1825						2220										2225					
	SIZE	250	500	630	1000	2000	3000	25	50	100	250	500	630	1000	1500	2000	3000	500	630	1000	1500	2000
RATED VOLTAGE (VDC)	250	500	630	1000	2000	3000	25	50	100	250	500	630	1000	1500	2000	3000	500	630	1000	1500	2000	3000
1,000pF (102)	K	K	K	K	K	K	K	K	K	K	K	K	K	K	K	K	K	K	K	K	K	K
1,200pF (122)	K	K	K	K	K	K	K	K	K	K	K	K	K	K	K	K	K	K	K	K	K	K
1,500pF (152)	K	K	K	K	K	K	K	K	K	K	K	K	K	K	K	K	K	K	K	K	K	K
1,800pF (182)	K	K	K	K	K	K	K	K	K	K	K	K	K	K	K	K	K	K	K	K	K	K
2,200pF (222)	K	K	K	K	K	K	K	K	K	K	K	K	K	K	K	K	K	K	K	K	K	K
2,700pF (272)	K	K	K	K	K	K	K	K	K	K	K	K	K	K	K	K	K	K	K	K	K	K
3,300pF (332)	K	K	K	K	K	K	K	K	K	K	K	K	K	K	K	K	K	K	K	K	K	K
3,900pF (392)	K	K	K	K	K	K	K	K	K	K	K	K	K	K	K	K	K	K	K	K	K	K
4,700pF (472)	K	K	K	K	K	K	K	K	K	K	K	K	K	K	K	K	K	K	K	K	K	K
5,600pF (562)	K	K	K	K	K	M	K	K	K	K	K	K	K	K	K	K	K	K	K	K	K	M
6,800pF (682)	K	K	K	K	K	M	K	K	K	K	K	K	K	K	K	M	K	K	K	K	K	M
8,200pF (822)	K	K	K	K	K	M	K	K	K	K	K	K	K	M	M	M	K	K	K	K	K	M
0.010µF (103)	K	K	K	K	K	M	K	K	K	K	K	K	K	M	M	M	K	K	K	K	K	M
0.012µF (123)	K	K	K	K	M	U	K	K	K	K	K	K	K	M	M	U	K	K	K	M	M	M
0.015µF (153)	K	K	K	K	M	U	K	K	K	K	K	K	K	M	M	U	K	K	K	M	M	M
0.018µF (183)	K	K	K	K	M	U	K	K	K	K	K	K	K	U	U	U	K	K	K	M	M	U
0.022µF (223)	K	K	K	K	M		K	K	K	K	K	K	K	U	U		K	K	K	M	M	
0.027µF (273)	K	K	K	K	U		K	K	K	K	K	K	K	U	U		K	K	K	M	M	
0.033µF (333)	K	K	K	K	U		K	K	K	K	K	K	K	U	U		K	K	K	M	M	
0.039µF (393)	K	K	K	K	U		K	K	K	K	K	K	K	U	U		K	K	K	M	U	
0.047µF (473)	K	K	K	K	U		K	K	K	K	K	K	K	U	U		K	K	K	M	U	
0.056µF (563)	K	K	K	K			K	K	K	K	K	K	K	U	U		K	K	K	M	U	
0.068µF (683)	K	K	K	K			K	K	K	K	K	K	K				K	K	K	M		
0.082µF (823)	K	K	K	M			K	K	K	K	K	K	K				K	K	K	M		
0.10µF (104)	K	K	K	M			K	K	K	K	K	K	K				K	K	K	M		
0.12µF (124)	K	K	K				K	K	K	K	K	K	M				K	K	U			
0.15µF (154)	K	K	K				K	K	K	K	K	K	U				K	K	U			
0.18µF (184)	K	K	K				K	K	K	K	K	K	U				K	K	U			
0.22µF (224)	K	K	K				K	K	K	K	K	K	U				K	K	U			
0.27µF (274)	K	K	K				K	K	K	K	K	K					K	K				
0.33µF (334)	K	K	K				K	K	K	K	K	K					K	K				
0.39µF (394)	K	K	K				K	K	K	K	K	K					K	K				
0.47µF (474)	K	K	K				K	K	K	K	K	K					K	K				
0.56µF (564)	K	M	M				K	K	K	K	M	M					K	K				
0.68µF (684)	K						K	K	K	K	M	M										
0.82µF (824)	K						K	K	K	K	U	U										
1.0µF (105)	K						K	K	K	K	U	U										
1.5µF (155)							K	K	K	M												
2.2µF (225)							K	K	K	M												
3.3µF (335)							K	K	K													
4.7µF (475)							K	K	M													
6.8µF (685)							M	M	M													
10µF (106)							M	M	M													
22µF (226)								U														

1. The letter in cell is expressed the symbol of product thickness.
2. For more information about products with special capacitance or other data, please contact WTC local representative.



Multilayer Ceramic Capacitors

**7-2. CAPACITANCE RANGE (X5R Dielectric)**

Dielectric		X5R																													
Size		0402				0603					0805					1206					1210										
Rated Voltage		6.3	10	16	25	6.3	10	16	25	50	6.3	10	16	25	50	6.3	10	16	25	50	6.3	10	16	25	50	6.3	10	16	25	50	
Capacitance	0.033μF (333)			E																											
	0.047μF (473)			E																											
	0.068μF (683)		E	E																											
	0.10μF (104)	E	E	E	E																										
	0.15μF (154)	E	E	E	E																										
	0.22μF (224)	E	E	E	E				X	X																					
	0.33μF (334)	E	E			X	X	X	X																						
	0.47μF (474)	E	E			X	X	X																							
	0.68μF (684)	E	E			X	X	X	X																						
	1.0μF (105)	E	E			X	X	X	X																						
	1.5μF (155)					X					I	I	I	I			J	J									K	K			
	2.2μF (225)					X	X	X			I	I	I	I			J	J	P								K	K			
	3.3μF (335)					X					I	I	I	I			P	P	P												
	4.7μF (475)					X											P	P	P	P							K	K	K		
	6.8μF (685)																P	P													
	10μF (106)																P	P	P	P							K	K	K		
22μF (226)																															

1. The letter in cell is expressed the symbol of product thickness.
2. For more information about products with special capacitance or other data, please contact WTC local representative.



**8. PACKAGING STYLE AND QUANTITY**

Size	Thickness (mm)/Symbol		Paper tape		Plastic tape	
			7" reel	13" reel	7" reel	13" reel
0402 (1005)	0.50±0.20	E	10k	-	-	-
0603 (1608)	0.80±0.07	S	4k	15k	-	-
	0.80±0.30	X	4k	15k	-	-
0805 (2012)	0.60±0.10	A	4k	15k	-	-
	0.80±0.10	B	4k	15k	-	-
	1.25±0.10	D	-	-	3k	10k
	1.25±0.30	I	-	-	3k	10k
1206 (3216)	0.80±0.10	B	4k	15k	-	-
	0.95±0.10	C	-	-	3k	10k
	1.15±0.15	J	-	-	3k	10k
	1.25±0.10	D	-	-	3k	10k
	1.60±0.20	G	-	-	2k	10k
	1.60±0.50	P	-	-	2k	9k
1210 (3225)	0.95±0.10	C	-	-	3k	10k
	1.25±0.10	D	-	-	3k	10k
	1.60±0.20	G	-	-	2k	8k
	2.00±0.20	K	-	-	1k	6k
	2.50±0.50	M	-	-	1k	6k
1808 (4520)	1.25±0.10	D	-	-	2k	10k
	1.60±0.20	G	-	-	2k	8k
	2.00±0.20	K	-	-	1k	6k
1812 (4532)	1.25±0.10	D	-	-	1k	5k
	1.60±0.20	G	-	-	1k	4k
	2.00±0.20	K	-	-	1k	3k
	2.50±0.50	M	-	-	0.5k	3k
1825 (4563)	2.00±0.20	K	-	-	1k	-
2220 (5750)	2.50±0.30	M	-	-	0.5k	-
2225 (5763)	2.80±0.30	U	-	-	0.5k	-

Unit: pieces

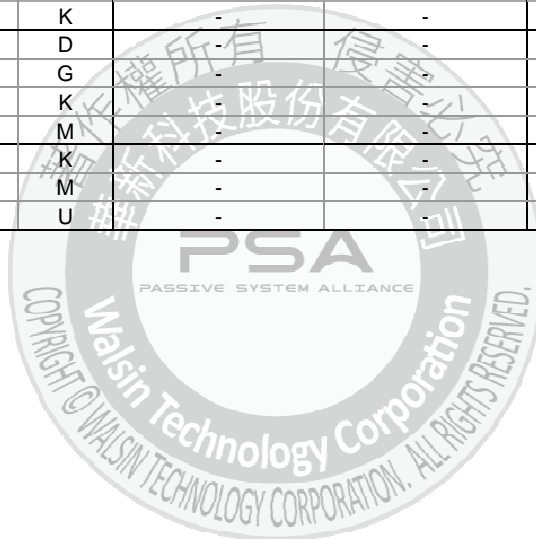

Multilayer Ceramic Capacitors

9. RELIABILITY TEST CONDITIONS AND REQUIREMENTS

No.	Item	Test Condition	Requirements																																								
1.	Visual and Mechanical	---	* No remarkable defect. * Dimensions to conform to individual specification sheet.																																								
2.	Capacitance	*Test temp.: Room Temperature. *Class I: (NP0) ≤ 1000pF, 1.0±0.2Vrms · 1MHz±10% > 1000pF, 1.0±0.2Vrms · 1KHz±10% Class II: (X7R, X7E, X6S, X5R, X7S) C ≤ 10μF, 1.0±0.2Vrms · 1KHz±10% ** C > 10μF, 0.5±0.2Vrms · 120Hz±20%	* Shall not exceed the limits given in the detailed spec. NP0: Cap≥30pF, Q≥1000; Cap<30pF, Q≥400+20C X7R, X5R, X6S, X7S:																																								
3.	Q/ D.F. (Dissipation Factor)	** Test condition: 0.5±0.2Vrms · 1KHz±10% X7R: 0603/475(6.3V) X5R: 0201 ≥ 224 (6.3V, 10V, 16V) #1, 0402 ≥ 475 (6.3V, 16V), 0402 ≥ 225(10V), 0603=106 (6.3V) TT18X ≥ 475(10V) , TT15X series X6S: 0201/474(4V), 0201 > 104 (6.3V, 10V), 0402 ≥ 225 (6.3V), 0402/475 (10V), 0603/106 (6.3V), X7S: 0402/225(6.3V)  #1 Excluding X5R/0201/105(6.3V); 225(10V) , 0402X475M6R3 (1.0±0.2Vrms · 1KHz±10%)  *Before initial measurement (Class II only): To apply de-aging at 150°C for 1hr then set for 24±2 hrs at room temp.	Rated vol.   D.F. ≤   Exception of D.F. ≤ <table border="1"> <thead> <tr> <th>Rated vol.</th> <th>D.F. ≤</th> <th>Exception of D.F. ≤</th> </tr> </thead> <tbody> <tr> <td rowspan="3">≥ 100V</td> <td rowspan="3">≤ 2.5%</td> <td>≤ 3%   1206 ≥ 0.47μF</td> </tr> <tr> <td>≤ 5%   0603 ≥ 0.068μF; 0805 &gt; 0.1μF; 1206 ≥ 1μF; 1210 ≥ 2.2μF; TT series</td> </tr> <tr> <td>≤ 10%   0805 &gt; 0.22μF; 1210 ≥ 3.3μF</td> </tr> <tr> <td rowspan="3">50V</td> <td rowspan="3">≤ 2.5%</td> <td>≤ 3%   0201(50V); 0603 ≥ 0.047μF; 0805 ≥ 0.18μF; 1206 ≥ 0.47μF</td> </tr> <tr> <td>≤ 5%   0201 ≥ 0.01μF; 1210 ≥ 3.3μF</td> </tr> <tr> <td>≤ 10%   0402 ≥ 0.012μF; 0603 &gt; 0.1μF; 0805 ≥ 1μF(0805/X7R &gt; 0.47μF); 1206 ≥ 2.2μF; 1210 ≥ 10μF; TT series</td> </tr> <tr> <td rowspan="3">35V</td> <td rowspan="3">≤ 3.5%</td> <td>≤ 10%   1206/X5R=10μF</td> </tr> <tr> <td>≤ 5%   0603 ≥ 1μF; 0805 ≥ 2.2μF; 1206 ≥ 2.2μF; 1210 ≥ 10μF</td> </tr> <tr> <td>≤ 7%   0201 ≥ 0.01μF(0201/X5R=0.01μF); 0805 ≥ 1μF; 1210 ≥ 10μF*</td> </tr> <tr> <td rowspan="3">25V</td> <td rowspan="3">≤ 3.5%</td> <td>≤ 5%   0603 ≥ 0.33μF</td> </tr> <tr> <td>≤ 10%   0201 ≥ 0.1μF(0201/X5R &gt; 0.01μF); 0603 ≥ 0.47μF; TT series; 0402 ≥ 0.10μF(0402/X7R ≥ 0.056μF); 0805 ≥ 2.2μF; 1206 ≥ 4.7μF; 1210 ≥ 22μF(1210/X5R ≥ 10μF)*</td> </tr> <tr> <td>≤ 12.5%   0402 ≥ 0.47μF; 0805/X5R/X6S=10μF</td> </tr> <tr> <td rowspan="3">16V</td> <td rowspan="3">≤ 3.5%</td> <td>≤ 5%   0201 ≥ 0.01μF(0201/X5R=0.01μF); 0402 ≥ 0.033μF; 0603 ≥ 0.15μF; 0805 ≥ 0.68μF; 1206 ≥ 2.2μF; 1210 ≥ 4.7μF</td> </tr> <tr> <td>≤ 10%   0201 ≥ 0.1μF(0201/X5R &gt; 0.01μF); 0201/X7R ≥ 0.022μF; 0402 ≥ 0.22μF; 0603 &gt; 0.47μF; 0805 ≥ 2.2μF; 1206 ≥ 4.7μF; 1210 ≥ 22μF; TT series</td> </tr> <tr> <td>≤ 12.5%   0402/X5R ≥ 1μF; 0402/X6S=1μF; 0805/X5R/X6S=10μF</td> </tr> <tr> <td rowspan="3">10V</td> <td rowspan="3">≤ 5%</td> <td>≤ 10%   0201 ≥ 0.012μF; 0402 ≥ 0.22μF; 0603 ≥ 0.33μF; TT series; 0805 ≥ 2.2μF; 1206 ≥ 2.2μF; 1210 ≥ 22μF; 01R5/X5R</td> </tr> <tr> <td>≤ 12.5%   0805/X5R/X6S=10μF</td> </tr> <tr> <td>≤ 15%   0201 ≥ 0.1μF(0201/X5R &gt; 0.1μF); 0402 ≥ 1μF; 0603/X5R ≥ 10μF</td> </tr> <tr> <td rowspan="2">6.3V</td> <td rowspan="2">≤ 10%</td> <td>≤ 15%   0201 ≥ 0.1μF(0201/X5R &gt; 0.1μF); 0402 ≥ 1μF(0402/X6S ≥ 0.47μF); 0603 ≥ 10μF; 0805 ≥ 4.7μF; 1206 ≥ 4.7μF; 1210 ≥ 100μF; TT series</td> </tr> <tr> <td>≤ 20%   0402 ≥ 2.2μF</td> </tr> <tr> <td>4V</td> <td>≤ 15%</td> <td>---</td> </tr> </tbody> </table>	Rated vol.	D.F. ≤	Exception of D.F. ≤	≥ 100V	≤ 2.5%	≤ 3%   1206 ≥ 0.47μF	≤ 5%   0603 ≥ 0.068μF; 0805 > 0.1μF; 1206 ≥ 1μF; 1210 ≥ 2.2μF; TT series	≤ 10%   0805 > 0.22μF; 1210 ≥ 3.3μF	50V	≤ 2.5%	≤ 3%   0201(50V); 0603 ≥ 0.047μF; 0805 ≥ 0.18μF; 1206 ≥ 0.47μF	≤ 5%   0201 ≥ 0.01μF; 1210 ≥ 3.3μF	≤ 10%   0402 ≥ 0.012μF; 0603 > 0.1μF; 0805 ≥ 1μF(0805/X7R > 0.47μF); 1206 ≥ 2.2μF; 1210 ≥ 10μF; TT series	35V	≤ 3.5%	≤ 10%   1206/X5R=10μF	≤ 5%   0603 ≥ 1μF; 0805 ≥ 2.2μF; 1206 ≥ 2.2μF; 1210 ≥ 10μF	≤ 7%   0201 ≥ 0.01μF(0201/X5R=0.01μF); 0805 ≥ 1μF; 1210 ≥ 10μF*	25V	≤ 3.5%	≤ 5%   0603 ≥ 0.33μF	≤ 10%   0201 ≥ 0.1μF(0201/X5R > 0.01μF); 0603 ≥ 0.47μF; TT series; 0402 ≥ 0.10μF(0402/X7R ≥ 0.056μF); 0805 ≥ 2.2μF; 1206 ≥ 4.7μF; 1210 ≥ 22μF(1210/X5R ≥ 10μF)*	≤ 12.5%   0402 ≥ 0.47μF; 0805/X5R/X6S=10μF	16V	≤ 3.5%	≤ 5%   0201 ≥ 0.01μF(0201/X5R=0.01μF); 0402 ≥ 0.033μF; 0603 ≥ 0.15μF; 0805 ≥ 0.68μF; 1206 ≥ 2.2μF; 1210 ≥ 4.7μF	≤ 10%   0201 ≥ 0.1μF(0201/X5R > 0.01μF); 0201/X7R ≥ 0.022μF; 0402 ≥ 0.22μF; 0603 > 0.47μF; 0805 ≥ 2.2μF; 1206 ≥ 4.7μF; 1210 ≥ 22μF; TT series	≤ 12.5%   0402/X5R ≥ 1μF; 0402/X6S=1μF; 0805/X5R/X6S=10μF	10V	≤ 5%	≤ 10%   0201 ≥ 0.012μF; 0402 ≥ 0.22μF; 0603 ≥ 0.33μF; TT series; 0805 ≥ 2.2μF; 1206 ≥ 2.2μF; 1210 ≥ 22μF; 01R5/X5R	≤ 12.5%   0805/X5R/X6S=10μF	≤ 15%   0201 ≥ 0.1μF(0201/X5R > 0.1μF); 0402 ≥ 1μF; 0603/X5R ≥ 10μF	6.3V	≤ 10%	≤ 15%   0201 ≥ 0.1μF(0201/X5R > 0.1μF); 0402 ≥ 1μF(0402/X6S ≥ 0.47μF); 0603 ≥ 10μF; 0805 ≥ 4.7μF; 1206 ≥ 4.7μF; 1210 ≥ 100μF; TT series	≤ 20%   0402 ≥ 2.2μF	4V	≤ 15%	---
Rated vol.	D.F. ≤	Exception of D.F. ≤																																									
≥ 100V	≤ 2.5%	≤ 3%   1206 ≥ 0.47μF																																									
		≤ 5%   0603 ≥ 0.068μF; 0805 > 0.1μF; 1206 ≥ 1μF; 1210 ≥ 2.2μF; TT series																																									
		≤ 10%   0805 > 0.22μF; 1210 ≥ 3.3μF																																									
50V	≤ 2.5%	≤ 3%   0201(50V); 0603 ≥ 0.047μF; 0805 ≥ 0.18μF; 1206 ≥ 0.47μF																																									
		≤ 5%   0201 ≥ 0.01μF; 1210 ≥ 3.3μF																																									
		≤ 10%   0402 ≥ 0.012μF; 0603 > 0.1μF; 0805 ≥ 1μF(0805/X7R > 0.47μF); 1206 ≥ 2.2μF; 1210 ≥ 10μF; TT series																																									
35V	≤ 3.5%	≤ 10%   1206/X5R=10μF																																									
		≤ 5%   0603 ≥ 1μF; 0805 ≥ 2.2μF; 1206 ≥ 2.2μF; 1210 ≥ 10μF																																									
		≤ 7%   0201 ≥ 0.01μF(0201/X5R=0.01μF); 0805 ≥ 1μF; 1210 ≥ 10μF*																																									
25V	≤ 3.5%	≤ 5%   0603 ≥ 0.33μF																																									
		≤ 10%   0201 ≥ 0.1μF(0201/X5R > 0.01μF); 0603 ≥ 0.47μF; TT series; 0402 ≥ 0.10μF(0402/X7R ≥ 0.056μF); 0805 ≥ 2.2μF; 1206 ≥ 4.7μF; 1210 ≥ 22μF(1210/X5R ≥ 10μF)*																																									
		≤ 12.5%   0402 ≥ 0.47μF; 0805/X5R/X6S=10μF																																									
16V	≤ 3.5%	≤ 5%   0201 ≥ 0.01μF(0201/X5R=0.01μF); 0402 ≥ 0.033μF; 0603 ≥ 0.15μF; 0805 ≥ 0.68μF; 1206 ≥ 2.2μF; 1210 ≥ 4.7μF																																									
		≤ 10%   0201 ≥ 0.1μF(0201/X5R > 0.01μF); 0201/X7R ≥ 0.022μF; 0402 ≥ 0.22μF; 0603 > 0.47μF; 0805 ≥ 2.2μF; 1206 ≥ 4.7μF; 1210 ≥ 22μF; TT series																																									
		≤ 12.5%   0402/X5R ≥ 1μF; 0402/X6S=1μF; 0805/X5R/X6S=10μF																																									
10V	≤ 5%	≤ 10%   0201 ≥ 0.012μF; 0402 ≥ 0.22μF; 0603 ≥ 0.33μF; TT series; 0805 ≥ 2.2μF; 1206 ≥ 2.2μF; 1210 ≥ 22μF; 01R5/X5R																																									
		≤ 12.5%   0805/X5R/X6S=10μF																																									
		≤ 15%   0201 ≥ 0.1μF(0201/X5R > 0.1μF); 0402 ≥ 1μF; 0603/X5R ≥ 10μF																																									
6.3V	≤ 10%	≤ 15%   0201 ≥ 0.1μF(0201/X5R > 0.1μF); 0402 ≥ 1μF(0402/X6S ≥ 0.47μF); 0603 ≥ 10μF; 0805 ≥ 4.7μF; 1206 ≥ 4.7μF; 1210 ≥ 100μF; TT series																																									
		≤ 20%   0402 ≥ 2.2μF																																									
4V	≤ 15%	---																																									
4.	Dielectric Strength	*To apply voltage: ≤ 100V: 250% of rated voltage. 200V ~ 300V: 200% of rated voltage. 400V ~ 450V: 120% of rated voltage. 500V ~ 999V: 150% of rated voltage. 1000V ~ 3000V: 120% of rated voltage. 4000V: 110% of rated voltage. *Duration: 1 to 5 sec. *Charge & discharge current less than 50mA.	* No evidence of damage or flash over during test.																																								

\* "Room condition" Temperature: 15 to 35°C, Relative humidity: 25 to 75%, Atmospheric pressure: 86 to 106kPa.

Multilayer Ceramic Capacitors

No.	Item	Test Condition	Requirements		
5.	Insulation Resistance	*Test temp.: Room Temperature.	10GΩ or RxC ≥ 500Ω-F whichever is smaller.		
		*To apply rated voltage for MAX. 120sec.	Class II (X7R, X7E, X5R, X6S, X7S)		
			Rated voltage	Insulation Resistance	
			100V: All X7R	10GΩ or RxC ≥ 100 Ω-F whichever is smaller.	
			50V: 0402 > 0.01μF; 0603 ≥ 1μF; 0805 ≥ 1μF; 1206 ≥ 4.7μF; 1210 ≥ 4.7μF		
			35V: 0805 ≥ 2.2μF; 1206 ≥ 2.2μF; 1210 ≥ 10μF		
			25V: 0402 ≥ 1μF; 0603 ≥ 2.2μF; 0805 ≥ 2.2μF; 1206 ≥ 10μF; 1210 ≥ 10μF		
			16V: 0201 ≥ 0.1μF; 0402 ≥ 0.22μF; 0603 ≥ 1μF; 0805 ≥ 2.2μF; 1206 ≥ 10μF; 1210 ≥ 47μF		
			10V: 0201 ≥ 47nF; 0402 ≥ 0.47μF; 0603 ≥ 0.47μF; 0805 ≥ 2.2μF; 1206 ≥ 4.7μF; 1210 ≥ 47μF		
			6.3V ; 4V ; TT series; Size ≥ 1812		
	Rated voltage	Insulation Resistance			
	All X6S items, All X7S items	RxC ≥ 50 Ω-F.			
	100V: 1210 ≥ 3.3μF				
	50V: 0402 ≥ 0.1μF; 0603 ≥ 2.2μF; 0805 ≥ 10μF; 1206 ≥ 10μF				
	35V: 0603 ≥ 1μF;				
	25V: 0201 ≥ 0.1μF; 0402 ≥ 2.2μF; 0603 ≥ 10μF; 0805 ≥ 10μF; 1206 ≥ 22μF				
	16V: 0603 ≥ 10μF; 0402 ≥ 1μF; 0201 ≥ 0.22μF				
	10V: 0201 > 0.1μF; 0402 ≥ 1μF; 0603 ≥ 10μF; 0805 ≥ 47μF; TT21 > 4.7μF				
	6.3V: 0201 ≥ 0.1μF; 0402 ≥ 1μF; 0603 > 4.7μF; 0805 ≥ 47μF; 1206 ≥ 10μF;				
	4V: 0603 ≥ 22μF; 0805 ≥ 47μF; 1206 ≥ 100μF				
	Rated voltage: 200~630V	To apply rated voltage (500V max.) for 60 sec.	≥ 10GΩ or RxC ≥ 100Ω-F whichever is smaller		
	Rated voltage: >630V	To apply 500V for 60 sec.			
6.	Temperature Coefficient	With no electrical load.			
		T.C.	Operating Temp	T.C.	Capacitance Change
		NPO	-55~125°C at 25°C	NPO	Within ±30ppm/°C
		X7R	-55~125°C at 25°C	X7R	Within ±15%
		X7S	-55~125°C at 25°C	X7S	Within ±22%
		X5R	-55~85°C at 25°C	X5R	Within ±15%
		X6S	-55~105°C at 25°C	X6S	Within ±22%
		*Before initial measurement (Class II only):			
		To apply de-aging at 150°C for 1hr then set for 24±2 hrs at room temp.			
		* Measurement voltage for Class II:			
01005		0201			
Cap ≤ 0.01μF: 0.5V		Cap ≤ 0.1μF: 1V			
Cap > 0.01μF: 0.2V		0.1μF ≤ Cap < 1μF: 0.2V*			
		Cap ≥ 1μF: 0.1V*			
*0201X104/6.3V~25V: 0.5V 0201X224&474/10V: 0.5V		*0201S104/6.3V~16V: 0.3V 0201S224/6.3V: 0.3V 0201X105/6.3V&10V: 0.3V			
0402		0603			
Cap < 1μF: 1V		Cap < 1μF: 1V			
Cap = 1μF: 0.5V** 0402B224-16V: 0.5V 0402B474-10V: 0.5V 0402X475M6R3: 0.5V		1μF ≤ Cap ≤ 4.7μF: 0.5V 0603X106-10V: 0.5V			
1μF < Cap < 10μF: 0.2V **0402B105M6R3V: 0.2V		Cap > 4.7μF: 0.2V			
Cap ≥ 10μF: 0.1V					
0805		1206/1210			
Cap < 10μF: 1V		Cap ≤ 10μF: 1V			
Cap = 10μF: 0.5V 0805B475/6.3V~25V: 0.5V		10μF < Cap ≤ 100μF: 0.5V			
Cap > 10μF: 0.2V		Cap > 100μF: 0.2V 1206X107-6.3V: 0.2V			

\* "Room condition" Temperature: 15 to 35°C, Relative humidity: 25 to 75%, Atmospheric pressure: 86 to 106kPa.

Multilayer Ceramic Capacitors

No.	Item	Test Condition	Requirements															
7.	Adhesive Strength of Termination	* Pressurizing force : 2N (0201) and 5N ( $\leq 0603$ ) and 10N ( $>0603$ ) * Test time: $10 \pm 1$ sec.	* No remarkable damage or removal of the terminations.															
8.	Vibration Resistance	* Vibration frequency: 10~55 Hz/min. * Total amplitude: 1.5mm * Test time: 6 hrs. (Two hrs each in three mutually perpendicular directions.) * Before initial measurement (Class II only): To apply de-aging at 150°C for 1hr then set for $24 \pm 2$ hrs at room temp. * Cap./DF(Q) Measurement to be made after de-aging at 150°C for 1hr then set for $24 \pm 2$ hrs at room temp.	* No remarkable damage. * Cap change and Q/D.F.: To meet initial spec.															
9.	Solderability	* Solder temperature: $235 \pm 5^\circ\text{C}$ * Dipping time: $2 \pm 0.5$ sec.	* 75% min. coverage of all metalized area.															
10.	Bending Test	* The middle part of substrate shall be pressurized by means of the pressurizing rod at a rate of about 1 mm per second until the deflection becomes 5 mm and then the pressure shall be maintained for $5 \pm 1$ sec. * Before initial measurement (Class II only): To apply de-aging at 150°C for 1hr then set for $24 \pm 2$ hrs at room temp. * Measurement to be made after keeping at room temp. for $24 \pm 2$ hrs.	* No remarkable damage. * Cap change : NP0: within $\pm 5\%$ or 0.5pF whichever is larger X7R, X5R, X6S, X7S: within $\pm 12.5\%$ (This capacitance change means the change of capacitance under specified flexure of substrate from the capacitance measured before the test.)															
11.	Resistance to Soldering Heat	* Solder temperature: $260 \pm 5^\circ\text{C}$ * Dipping time: $10 \pm 1$ sec * Preheating: 120 to 150°C for 1 minute before immerse the capacitor in a eutectic solder. * Before initial measurement (Class II only): To apply de-aging at 150°C for 1hr then set for $24 \pm 2$ hrs at room temp. * Cap. / DF(Q) / I.R. Measurement to be made after de-aging at 150°C for 1hr then set for $24 \pm 2$ hrs at room temp.	* No remarkable damage. * Cap change: NP0: within $\pm 2.5\%$ or 0.25pF whichever is larger X7R, X5R, X6S, X7S: within $\pm 7.5\%$ * Q/D.F., I.R. and dielectric strength: To meet initial requirements. * 25% max. leaching on each edge.															
12.	Temperature Cycle	* Conduct the five cycles according to the temperatures and time. <table border="1" data-bbox="391 1153 829 1288"> <thead> <tr> <th>Step</th> <th>Temp. (°C)</th> <th>Time (min.)</th> </tr> </thead> <tbody> <tr> <td>1</td> <td>Min. operating temp. +0/-3</td> <td>30<math>\pm</math>3</td> </tr> <tr> <td>2</td> <td>Room temp.</td> <td>2~3</td> </tr> <tr> <td>3</td> <td>Max. operating temp. +3/-0</td> <td>30<math>\pm</math>3</td> </tr> <tr> <td>4</td> <td>Room temp.</td> <td>2~3</td> </tr> </tbody> </table> * Before initial measurement (Class II only): To apply de-aging at 150°C for 1hr then set for $24 \pm 2$ hrs at room temp. * Cap. / DF(Q) / I.R. Measurement to be made after de-aging at 150°C for 1hr then set for $24 \pm 2$ hrs at room temp.	Step	Temp. (°C)	Time (min.)	1	Min. operating temp. +0/-3	30 $\pm$ 3	2	Room temp.	2~3	3	Max. operating temp. +3/-0	30 $\pm$ 3	4	Room temp.	2~3	* No remarkable damage. * Cap change : NP0: within $\pm 2.5\%$ or 0.25pF whichever is larger X7R, X5R, X6S, X7S: within $\pm 7.5\%$ * Q/D.F., I.R. and dielectric strength: To meet initial requirements.
Step	Temp. (°C)	Time (min.)																
1	Min. operating temp. +0/-3	30 $\pm$ 3																
2	Room temp.	2~3																
3	Max. operating temp. +3/-0	30 $\pm$ 3																
4	Room temp.	2~3																

\* "Room condition" Temperature: 15 to 35°C, Relative humidity: 25 to 75%, Atmospheric pressure: 86 to 106kPa.

Multilayer Ceramic Capacitors

No.	Item	Test Condition	Requirements																																								
13.	Humidity (Damp Heat) Steady State	*Test temp.: 40±2°C *Humidity: 90-95%RH *Test time: 500+24/-0hrs. *Before initial measurement (Class II only): To apply de-aging at 150°C for 1hr then set for 24±2 hrs at room temp. * Cap. / DF(Q) / I.R. Measurement to be made after de-aging at 150°C for 1hr then set for 24±2 hrs at room temp.	* No remarkable damage. * Cap change: NP0: within ±5% or 0.5pF whichever is larger X7R, X5R, X6S, X7S: ≥10V**, within ±12.5%; ≤6.3V within ±25%; TT series & C≥ 1uF, within ±25% **10V: 0603≥4.7μF;0402≥1μF;0201≥0.1μF, within ±25%; * Q/D.F. value: NP0: More than 30pF Q≥350, 10pF≤C<30pF, Q≥275+2.5C Less than 10pF Q≥200+10C X7R, X5R, X6S, X7S:																																								
			<table border="1"> <thead> <tr> <th>Rated vol.</th> <th>D.F. ≤</th> <th>Exception of D.F. ≤</th> </tr> </thead> <tbody> <tr> <td rowspan="3">100V</td> <td rowspan="3">≤3%</td> <td>≤6% 1206≥0.47μF</td> </tr> <tr> <td>≤7.5% 0603≥0.068μF;0805&gt;0.1μF;1206≥1μF;1210≥2.2μF;TT series</td> </tr> <tr> <td>≤20% 0805&gt;0.22μF;1210≥3.3μF</td> </tr> <tr> <td rowspan="3">50V</td> <td rowspan="3">≤3%</td> <td>≤6% 0201(50V);0603≥0.047μF;0805≥0.18μF;1206≥0.47μF</td> </tr> <tr> <td>≤10% 0201≥0.01uF;1210≥3.3μF</td> </tr> <tr> <td>≤20% 0402≥0.012μF;0603&gt;0.1μF;0805≥1μF(0805/X7R&gt;0.47μF); 1206≥2.2μF;1210≥10μF; TT series</td> </tr> <tr> <td rowspan="3">35V</td> <td rowspan="3">≤5%</td> <td>≤20% 0603≥1μF;0805≥2.2μF;1206≥2.2μF;1210≥10μF</td> </tr> <tr> <td>≤10% 0201≥0.01μF(0201/X5R=0.01μF);0805≥1μF;1210≥10μF*</td> </tr> <tr> <td>≤14% 0603≥0.33μF</td> </tr> <tr> <td rowspan="3">25V</td> <td rowspan="3">≤5%</td> <td>0201≥0.1μF(0201/X5R&gt;0.01μF); 0603≥0.47μF;TTseries</td> </tr> <tr> <td>≤15% 0402≥0.10μF(0402/X7R≥0.056μF);0805≥2.2μF; 1206≥4.7μF;1210≥22μF(1210/X5R≥10μF)*;</td> </tr> <tr> <td>≤20% 0402≥0.47μF</td> </tr> <tr> <td rowspan="3">16V</td> <td rowspan="3">≤5%</td> <td>≤10% 0603≥0.15μF;0805≥0.68μF;1206≥2.2μF;1210≥4.7μF</td> </tr> <tr> <td>≤15% 0201≥0.01μF(0201/X7R≥0.022μF);0402≥0.033μF; 0603&gt;0.47μF;0805≥2.2μF;1206≥4.7μF;1210≥22μF;TT series</td> </tr> <tr> <td>0201≥0.012μF;0402≥0.22μF;</td> </tr> <tr> <td rowspan="3">10V</td> <td rowspan="3">≤7.5%</td> <td>≤15% 0603≥0.33μF;0805≥2.2μF;1206≥2.2μF;1210≥22μF</td> </tr> <tr> <td>≤20% 0201≥0.1μF;0402≥1μF;0603/X5R≥10μF;TT series;01R5/X5R</td> </tr> <tr> <td>0201≥0.1μF;0402≥1μF(0402/X6S≥0.47μF);</td> </tr> <tr> <td rowspan="2">6.3V</td> <td rowspan="2">≤15%</td> <td>≤30% 0603≥10μF;0805≥4.7μF;1206≥47μF;1210≥100μF;TT series</td> </tr> <tr> <td>---</td> </tr> <tr> <td>4V</td> <td>≤20%</td> <td>---</td> </tr> </tbody> </table>	Rated vol.	D.F. ≤	Exception of D.F. ≤	100V	≤3%	≤6% 1206≥0.47μF	≤7.5% 0603≥0.068μF;0805>0.1μF;1206≥1μF;1210≥2.2μF;TT series	≤20% 0805>0.22μF;1210≥3.3μF	50V	≤3%	≤6% 0201(50V);0603≥0.047μF;0805≥0.18μF;1206≥0.47μF	≤10% 0201≥0.01uF;1210≥3.3μF	≤20% 0402≥0.012μF;0603>0.1μF;0805≥1μF(0805/X7R>0.47μF); 1206≥2.2μF;1210≥10μF; TT series	35V	≤5%	≤20% 0603≥1μF;0805≥2.2μF;1206≥2.2μF;1210≥10μF	≤10% 0201≥0.01μF(0201/X5R=0.01μF);0805≥1μF;1210≥10μF*	≤14% 0603≥0.33μF	25V	≤5%	0201≥0.1μF(0201/X5R>0.01μF); 0603≥0.47μF;TTseries	≤15% 0402≥0.10μF(0402/X7R≥0.056μF);0805≥2.2μF; 1206≥4.7μF;1210≥22μF(1210/X5R≥10μF)*;	≤20% 0402≥0.47μF	16V	≤5%	≤10% 0603≥0.15μF;0805≥0.68μF;1206≥2.2μF;1210≥4.7μF	≤15% 0201≥0.01μF(0201/X7R≥0.022μF);0402≥0.033μF; 0603>0.47μF;0805≥2.2μF;1206≥4.7μF;1210≥22μF;TT series	0201≥0.012μF;0402≥0.22μF;	10V	≤7.5%	≤15% 0603≥0.33μF;0805≥2.2μF;1206≥2.2μF;1210≥22μF	≤20% 0201≥0.1μF;0402≥1μF;0603/X5R≥10μF;TT series;01R5/X5R	0201≥0.1μF;0402≥1μF(0402/X6S≥0.47μF);	6.3V	≤15%	≤30% 0603≥10μF;0805≥4.7μF;1206≥47μF;1210≥100μF;TT series	---	4V	≤20%	---
Rated vol.	D.F. ≤	Exception of D.F. ≤																																									
100V	≤3%	≤6% 1206≥0.47μF																																									
		≤7.5% 0603≥0.068μF;0805>0.1μF;1206≥1μF;1210≥2.2μF;TT series																																									
		≤20% 0805>0.22μF;1210≥3.3μF																																									
50V	≤3%	≤6% 0201(50V);0603≥0.047μF;0805≥0.18μF;1206≥0.47μF																																									
		≤10% 0201≥0.01uF;1210≥3.3μF																																									
		≤20% 0402≥0.012μF;0603>0.1μF;0805≥1μF(0805/X7R>0.47μF); 1206≥2.2μF;1210≥10μF; TT series																																									
35V	≤5%	≤20% 0603≥1μF;0805≥2.2μF;1206≥2.2μF;1210≥10μF																																									
		≤10% 0201≥0.01μF(0201/X5R=0.01μF);0805≥1μF;1210≥10μF*																																									
		≤14% 0603≥0.33μF																																									
25V	≤5%	0201≥0.1μF(0201/X5R>0.01μF); 0603≥0.47μF;TTseries																																									
		≤15% 0402≥0.10μF(0402/X7R≥0.056μF);0805≥2.2μF; 1206≥4.7μF;1210≥22μF(1210/X5R≥10μF)*;																																									
		≤20% 0402≥0.47μF																																									
16V	≤5%	≤10% 0603≥0.15μF;0805≥0.68μF;1206≥2.2μF;1210≥4.7μF																																									
		≤15% 0201≥0.01μF(0201/X7R≥0.022μF);0402≥0.033μF; 0603>0.47μF;0805≥2.2μF;1206≥4.7μF;1210≥22μF;TT series																																									
		0201≥0.012μF;0402≥0.22μF;																																									
10V	≤7.5%	≤15% 0603≥0.33μF;0805≥2.2μF;1206≥2.2μF;1210≥22μF																																									
		≤20% 0201≥0.1μF;0402≥1μF;0603/X5R≥10μF;TT series;01R5/X5R																																									
		0201≥0.1μF;0402≥1μF(0402/X6S≥0.47μF);																																									
6.3V	≤15%	≤30% 0603≥10μF;0805≥4.7μF;1206≥47μF;1210≥100μF;TT series																																									
		---																																									
4V	≤20%	---																																									
			*I.R.: ≥10V, 1GΩ or 50 Ω-F whichever is smaller. Class II (X7R, X5R, X6S, X7S)																																								
			<table border="1"> <thead> <tr> <th>Rated voltage</th> <th>Insulation Resistance</th> </tr> </thead> <tbody> <tr> <td>100V: All X7R;1210≥3.3μF</td> <td rowspan="7">1GΩ or RxC ≥ 10 Ω-F whichever is smaller.</td> </tr> <tr> <td>50V: 0402&gt;0.01μF;0603≥1μF;0805≥1μF;1206≥4.7μF;1210≥4.7μF</td> </tr> <tr> <td>35V:0603≥1μF;0805≥2.2μF; 1206≥2.2μF;1210≥10μF</td> </tr> <tr> <td>25V:0201≥0.1μF; 0402≥0.22μF; 0603≥2.2μF;0805≥2.2μF; 1206≥10μF;1210≥10μF</td> </tr> <tr> <td>16V: 0201 ≥ 0.1uF;0402≥0.22μF;0603≥1μF;0805≥2.2μF; 1206≥10μF;1210≥47μF</td> </tr> <tr> <td>10V:0201≥47nF;0402≥0.47μF;0603≥0.47μF;0805≥2.2μF; 1206≥4.7μF;1210≥47μF</td> </tr> <tr> <td>6.3V ; 4V ; TT series ; All X6S/X7S items; Size≥1812</td> </tr> </tbody> </table>	Rated voltage	Insulation Resistance	100V: All X7R;1210≥3.3μF	1GΩ or RxC ≥ 10 Ω-F whichever is smaller.	50V: 0402>0.01μF;0603≥1μF;0805≥1μF;1206≥4.7μF;1210≥4.7μF	35V:0603≥1μF;0805≥2.2μF; 1206≥2.2μF;1210≥10μF	25V:0201≥0.1μF; 0402≥0.22μF; 0603≥2.2μF;0805≥2.2μF; 1206≥10μF;1210≥10μF	16V: 0201 ≥ 0.1uF;0402≥0.22μF;0603≥1μF;0805≥2.2μF; 1206≥10μF;1210≥47μF	10V:0201≥47nF;0402≥0.47μF;0603≥0.47μF;0805≥2.2μF; 1206≥4.7μF;1210≥47μF	6.3V ; 4V ; TT series ; All X6S/X7S items; Size≥1812																														
Rated voltage	Insulation Resistance																																										
100V: All X7R;1210≥3.3μF	1GΩ or RxC ≥ 10 Ω-F whichever is smaller.																																										
50V: 0402>0.01μF;0603≥1μF;0805≥1μF;1206≥4.7μF;1210≥4.7μF																																											
35V:0603≥1μF;0805≥2.2μF; 1206≥2.2μF;1210≥10μF																																											
25V:0201≥0.1μF; 0402≥0.22μF; 0603≥2.2μF;0805≥2.2μF; 1206≥10μF;1210≥10μF																																											
16V: 0201 ≥ 0.1uF;0402≥0.22μF;0603≥1μF;0805≥2.2μF; 1206≥10μF;1210≥47μF																																											
10V:0201≥47nF;0402≥0.47μF;0603≥0.47μF;0805≥2.2μF; 1206≥4.7μF;1210≥47μF																																											
6.3V ; 4V ; TT series ; All X6S/X7S items; Size≥1812																																											

\* "Room condition" Temperature: 15 to 35°C, Relative humidity: 25 to 75%, Atmospheric pressure: 86 to 106kPa.

Multilayer Ceramic Capacitors

No	Item	Test Condition	Requirements																																													
14	Humidity (Damp Heat) Load	*Test temp. : 40±2°C *Humidity : 90~95%RH *Test time : 500+24/-0 hrs. *To apply voltage : Rated voltage (MAX. 500V) *Before initial measurement (Class II only): To apply de-aging at 150°C for 1hr then set for 24±2 hrs at room temp. * Cap. / DF(Q) / I.R. Measurement to be made after de-aging at 150°C for 1hr then set for 24±2 hrs at room temp.	* No remarkable damage. Cap change: NP0: ±7.5% or 0.75pF whichever is larger. X7R, X5R, X6S, X7S: ≥10V**, within ±12.5%; ≤6.3V within ±25%; TT series & C≥ 1uF, within ±25% **10V: 0603≥4.7μF;0402≥1μF;0201≥0.1μF, within ±25%; Q/D.F. value: NP0: C≥30pF,Q≥200;C<30pF, Q≥100+10/3C X7R, X5R, X6S, X7S:																																													
			<table border="1"> <thead> <tr> <th>Rated vol.</th> <th>D.F. ≤</th> <th>Exception of D.F. ≤</th> </tr> </thead> <tbody> <tr> <td rowspan="3">100V</td> <td>≤6%</td> <td>1206 ≥ 0.47μF</td> </tr> <tr> <td>≤7.5%</td> <td>0603 ≥ 0.068μF;0805 &gt; 0.1μF;1206 ≥ 1μF;1210 ≥ 2.2μF;TT series</td> </tr> <tr> <td>≤20%</td> <td>0805 &gt; 0.22μF;1210 ≥ 3.3μF</td> </tr> <tr> <td rowspan="3">50V</td> <td>≤6%</td> <td>0201(50V);0603 ≥ 0.047μF;0805 ≥ 0.18μF;1206 ≥ 0.47μF</td> </tr> <tr> <td>≤10%</td> <td>0201 ≥ 0.01uF;1210 ≥ 3.3μF</td> </tr> <tr> <td>≤20%</td> <td>0402 ≥ 0.012μF;0603&gt;0.1μF;0805 ≥ 1μF(0805/X7R&gt;0.47μF); 1206 ≥ 2.2μF;1210 ≥ 10μF; TT series</td> </tr> <tr> <td>35V</td> <td>≤5%</td> <td>≤20% 0603 ≥ 1μF;0805≥2.2μF;1206 ≥ 2.2μF;1210 ≥ 10μF</td> </tr> <tr> <td rowspan="4">25V</td> <td>≤10%</td> <td>0201 ≥ 0.01μF(0201/X5R=0.01μF);0805 ≥ 1μF;1210 ≥ 10μF*</td> </tr> <tr> <td>≤14%</td> <td>0603 ≥ 0.33μF</td> </tr> <tr> <td>≤5%</td> <td>0201 ≥ 0.1μF(0201/X5R&gt;0.01μF); 0603 ≥ 0.47μF;TTseries 0402 ≥ 0.10μF(0402/X7R ≥ 0.056μF);0805 ≥ 2.2μF; 1206 ≥ 4.7μF;1210 ≥ 22μF(1210/X5R ≥ 10μF)*;</td> </tr> <tr> <td>≤20%</td> <td>0402 ≥ 0.47μF</td> </tr> <tr> <td rowspan="2">16V</td> <td>≤5%</td> <td>≤10% 0603 ≥ 0.15μF;0805 ≥ 0.68μF;1206 ≥ 2.2μF;1210 ≥ 4.7μF</td> </tr> <tr> <td>≤15%</td> <td>0201 ≥ 0.01μF(0201/X7R ≥ 0.022μF);0402 ≥ 0.033μF; 0603&gt;0.47μF;0805 ≥ 2.2μF;1206 ≥ 4.7μF;1210 ≥ 22μF;TT series</td> </tr> <tr> <td rowspan="2">10V</td> <td>≤7.5%</td> <td>≤15% 0201 ≥ 0.012μF;0402 ≥ 0.22μF; 0603 ≥ 0.33μF;0805 ≥ 2.2μF;1206 ≥ 2.2μF;1210 ≥ 22μF</td> </tr> <tr> <td>≤20%</td> <td>0201 ≥ 0.1μF;0402 ≥ 1μF;0603/X5R ≥ 10μF;TT series;01R5/X5R</td> </tr> <tr> <td>6.3V</td> <td>≤15%</td> <td>≤30% 0201 ≥ 0.1μF;0402 ≥ 1μF(0402/X6S ≥ 0.47μF); 0603 ≥ 10μF;0805 ≥ 4.7μF;1206 ≥ 47μF;1210 ≥ 100μF;TT series</td> </tr> <tr> <td>4V</td> <td>≤20%</td> <td>---</td> </tr> </tbody> </table>	Rated vol.	D.F. ≤	Exception of D.F. ≤	100V	≤6%	1206 ≥ 0.47μF	≤7.5%	0603 ≥ 0.068μF;0805 > 0.1μF;1206 ≥ 1μF;1210 ≥ 2.2μF;TT series	≤20%	0805 > 0.22μF;1210 ≥ 3.3μF	50V	≤6%	0201(50V);0603 ≥ 0.047μF;0805 ≥ 0.18μF;1206 ≥ 0.47μF	≤10%	0201 ≥ 0.01uF;1210 ≥ 3.3μF	≤20%	0402 ≥ 0.012μF;0603>0.1μF;0805 ≥ 1μF(0805/X7R>0.47μF); 1206 ≥ 2.2μF;1210 ≥ 10μF; TT series	35V	≤5%	≤20% 0603 ≥ 1μF;0805≥2.2μF;1206 ≥ 2.2μF;1210 ≥ 10μF	25V	≤10%	0201 ≥ 0.01μF(0201/X5R=0.01μF);0805 ≥ 1μF;1210 ≥ 10μF*	≤14%	0603 ≥ 0.33μF	≤5%	0201 ≥ 0.1μF(0201/X5R>0.01μF); 0603 ≥ 0.47μF;TTseries 0402 ≥ 0.10μF(0402/X7R ≥ 0.056μF);0805 ≥ 2.2μF; 1206 ≥ 4.7μF;1210 ≥ 22μF(1210/X5R ≥ 10μF)*;	≤20%	0402 ≥ 0.47μF	16V	≤5%	≤10% 0603 ≥ 0.15μF;0805 ≥ 0.68μF;1206 ≥ 2.2μF;1210 ≥ 4.7μF	≤15%	0201 ≥ 0.01μF(0201/X7R ≥ 0.022μF);0402 ≥ 0.033μF; 0603>0.47μF;0805 ≥ 2.2μF;1206 ≥ 4.7μF;1210 ≥ 22μF;TT series	10V	≤7.5%	≤15% 0201 ≥ 0.012μF;0402 ≥ 0.22μF; 0603 ≥ 0.33μF;0805 ≥ 2.2μF;1206 ≥ 2.2μF;1210 ≥ 22μF	≤20%	0201 ≥ 0.1μF;0402 ≥ 1μF;0603/X5R ≥ 10μF;TT series;01R5/X5R	6.3V	≤15%	≤30% 0201 ≥ 0.1μF;0402 ≥ 1μF(0402/X6S ≥ 0.47μF); 0603 ≥ 10μF;0805 ≥ 4.7μF;1206 ≥ 47μF;1210 ≥ 100μF;TT series	4V	≤20%	---
Rated vol.	D.F. ≤	Exception of D.F. ≤																																														
100V	≤6%	1206 ≥ 0.47μF																																														
	≤7.5%	0603 ≥ 0.068μF;0805 > 0.1μF;1206 ≥ 1μF;1210 ≥ 2.2μF;TT series																																														
	≤20%	0805 > 0.22μF;1210 ≥ 3.3μF																																														
50V	≤6%	0201(50V);0603 ≥ 0.047μF;0805 ≥ 0.18μF;1206 ≥ 0.47μF																																														
	≤10%	0201 ≥ 0.01uF;1210 ≥ 3.3μF																																														
	≤20%	0402 ≥ 0.012μF;0603>0.1μF;0805 ≥ 1μF(0805/X7R>0.47μF); 1206 ≥ 2.2μF;1210 ≥ 10μF; TT series																																														
35V	≤5%	≤20% 0603 ≥ 1μF;0805≥2.2μF;1206 ≥ 2.2μF;1210 ≥ 10μF																																														
25V	≤10%	0201 ≥ 0.01μF(0201/X5R=0.01μF);0805 ≥ 1μF;1210 ≥ 10μF*																																														
	≤14%	0603 ≥ 0.33μF																																														
	≤5%	0201 ≥ 0.1μF(0201/X5R>0.01μF); 0603 ≥ 0.47μF;TTseries 0402 ≥ 0.10μF(0402/X7R ≥ 0.056μF);0805 ≥ 2.2μF; 1206 ≥ 4.7μF;1210 ≥ 22μF(1210/X5R ≥ 10μF)*;																																														
	≤20%	0402 ≥ 0.47μF																																														
16V	≤5%	≤10% 0603 ≥ 0.15μF;0805 ≥ 0.68μF;1206 ≥ 2.2μF;1210 ≥ 4.7μF																																														
	≤15%	0201 ≥ 0.01μF(0201/X7R ≥ 0.022μF);0402 ≥ 0.033μF; 0603>0.47μF;0805 ≥ 2.2μF;1206 ≥ 4.7μF;1210 ≥ 22μF;TT series																																														
10V	≤7.5%	≤15% 0201 ≥ 0.012μF;0402 ≥ 0.22μF; 0603 ≥ 0.33μF;0805 ≥ 2.2μF;1206 ≥ 2.2μF;1210 ≥ 22μF																																														
	≤20%	0201 ≥ 0.1μF;0402 ≥ 1μF;0603/X5R ≥ 10μF;TT series;01R5/X5R																																														
6.3V	≤15%	≤30% 0201 ≥ 0.1μF;0402 ≥ 1μF(0402/X6S ≥ 0.47μF); 0603 ≥ 10μF;0805 ≥ 4.7μF;1206 ≥ 47μF;1210 ≥ 100μF;TT series																																														
4V	≤20%	---																																														
			*I.R.: ≥10V, 500MΩ or 25 Ω-F whichever is smaller. Class II (X7R, X5R, X6S, X7S)																																													
			<table border="1"> <thead> <tr> <th>Rated voltage</th> <th>Insulation Resistance</th> </tr> </thead> <tbody> <tr> <td>100V: All X7R;1210≥3.3μF</td> <td rowspan="6">500MΩ or RxC ≥ 5 Ω-F whichever is smaller.</td> </tr> <tr> <td>50V: 0402&gt;0.01μF;0603≥1μF;0805≥1μF;1206≥4.7μF;1210≥4.7μF</td> </tr> <tr> <td>35V:0603≥1μF;0805≥2.2μF; 1206 ≥ 2.2μF;1210 ≥ 10μF</td> </tr> <tr> <td>25V:0201 ≥ 0.1μF; 0402≥0.22μF; 0603≥2.2μF;0805≥2.2μF; 1206≥10μF;1210≥10μF</td> </tr> <tr> <td>16V: 0201 ≥ 0.1μF;0402≥0.22μF;0603≥1μF;0805≥2.2μF; 1206≥10μF;1210≥47μF</td> </tr> <tr> <td>10V:0201≥47nF;0402≥0.47μF;0603≥0.47μF;0805≥2.2μF; 1206≥4.7μF;1210≥47μF</td> </tr> <tr> <td>6.3V ; 4V ; TT series ; All X6S/X7S items; Size≥1812</td> <td></td> </tr> </tbody> </table>	Rated voltage	Insulation Resistance	100V: All X7R;1210≥3.3μF	500MΩ or RxC ≥ 5 Ω-F whichever is smaller.	50V: 0402>0.01μF;0603≥1μF;0805≥1μF;1206≥4.7μF;1210≥4.7μF	35V:0603≥1μF;0805≥2.2μF; 1206 ≥ 2.2μF;1210 ≥ 10μF	25V:0201 ≥ 0.1μF; 0402≥0.22μF; 0603≥2.2μF;0805≥2.2μF; 1206≥10μF;1210≥10μF	16V: 0201 ≥ 0.1μF;0402≥0.22μF;0603≥1μF;0805≥2.2μF; 1206≥10μF;1210≥47μF	10V:0201≥47nF;0402≥0.47μF;0603≥0.47μF;0805≥2.2μF; 1206≥4.7μF;1210≥47μF	6.3V ; 4V ; TT series ; All X6S/X7S items; Size≥1812																																			
Rated voltage	Insulation Resistance																																															
100V: All X7R;1210≥3.3μF	500MΩ or RxC ≥ 5 Ω-F whichever is smaller.																																															
50V: 0402>0.01μF;0603≥1μF;0805≥1μF;1206≥4.7μF;1210≥4.7μF																																																
35V:0603≥1μF;0805≥2.2μF; 1206 ≥ 2.2μF;1210 ≥ 10μF																																																
25V:0201 ≥ 0.1μF; 0402≥0.22μF; 0603≥2.2μF;0805≥2.2μF; 1206≥10μF;1210≥10μF																																																
16V: 0201 ≥ 0.1μF;0402≥0.22μF;0603≥1μF;0805≥2.2μF; 1206≥10μF;1210≥47μF																																																
10V:0201≥47nF;0402≥0.47μF;0603≥0.47μF;0805≥2.2μF; 1206≥4.7μF;1210≥47μF																																																
6.3V ; 4V ; TT series ; All X6S/X7S items; Size≥1812																																																

\* "Room condition" Temperature: 15 to 35°C, Relative humidity: 25 to 75%, Atmospheric pressure: 86 to 106kPa.

Multilayer Ceramic Capacitors

No	Item	Test Condition	Requirements																																																																																																																													
15.	High Temperature Load (Endurance)	Test temp. : NP0, X7R/X7E/X7S: 125±3°C X6S: 105±3°C X5R: 85±3°C Test time: 1000+24/-0 hrs. To apply voltage: (1) 100% of rated voltage for below range.	* No remarkable damage. Cap change: NP0: ±3.0% or ±0.3pF whichever is larger X7R, X5R, X6S, X7S: ≥10V**, within ±12.5%; ≤6.3V within ±25%; TT series & C ≥ 1uF, within ±25% **10V: 0603 ≥ 4.7μF; 0402 ≥ 1μF; 0201 ≥ 0.1μF, within ±25%; Q/D.F. value: NP0: More than 30pF, Q ≥ 350 10pF ≤ C < 30pF, Q ≥ 275 + 2.5C Less than 10pF, Q ≥ 200 + 10C X7R, X5R, X6S, X7S:																																																																																																																													
		<table border="1"> <thead> <tr> <th>Size</th> <th>Dielectric</th> <th>Rated voltage</th> <th>Capacitance</th> </tr> </thead> <tbody> <tr> <td rowspan="2">0201</td> <td rowspan="2">X5R/X7R/ X6S/X7S</td> <td>≤ 10V</td> <td>C ≥ 0.1μF</td> </tr> <tr> <td>≥ 16V</td> <td>C &gt; 0.1μF</td> </tr> <tr> <td rowspan="4">0402</td> <td rowspan="2">X5R</td> <td>≤ 16V</td> <td>C &gt; 1.0μF</td> </tr> <tr> <td>25V, 50V</td> <td>C ≥ 1.0μF</td> </tr> <tr> <td rowspan="2">X6S</td> <td>6.3V, 10V</td> <td>C &gt; 1.0μF</td> </tr> <tr> <td>16V, 25V</td> <td>C ≥ 1.0μF</td> </tr> <tr> <td>X7R/X7S/Y5V</td> <td>6.3V, 10V</td> <td>C ≥ 1.0μF</td> </tr> <tr> <td rowspan="4">0603</td> <td rowspan="2">X5R/X7R/ X6S/X7S</td> <td>4V</td> <td>C ≥ 22μF</td> </tr> <tr> <td>6.3V, 10V</td> <td>C ≥ 4.7μF<sup>1)</sup></td> </tr> <tr> <td rowspan="2">X5R/X6S/X7S</td> <td>25V</td> <td>C ≥ 1.0μF</td> </tr> <tr> <td>X7R</td> <td>35V</td> <td>C ≥ 1.0μF</td> </tr> <tr> <td rowspan="5">0805</td> <td rowspan="3">X5R/X7R/ X6S/X7S</td> <td>4V</td> <td>C ≥ 47μF</td> </tr> <tr> <td>6.3V</td> <td>C ≥ 22μF</td> </tr> <tr> <td>10V, 50V</td> <td>C ≥ 10μF</td> </tr> <tr> <td rowspan="2">X6S</td> <td>16V</td> <td>C &gt; 10μF</td> </tr> <tr> <td>25V</td> <td>C ≥ 10μF</td> </tr> <tr> <td>X7R/X7S</td> <td>16V, 25V</td> <td>C ≥ 10μF</td> </tr> <tr> <td>1206</td> <td>X5R/X7R/X6S</td> <td>≤ 6.3V</td> <td>C ≥ 47μF</td> </tr> <tr> <td rowspan="2">1210</td> <td rowspan="2">X5R/X7R/X6S</td> <td>16V</td> <td>C ≥ 47μF</td> </tr> <tr> <td>X7R</td> <td>100V</td> <td>C ≥ 3.3μF</td> </tr> </tbody> </table>	Size	Dielectric	Rated voltage	Capacitance	0201	X5R/X7R/ X6S/X7S	≤ 10V	C ≥ 0.1μF	≥ 16V	C > 0.1μF	0402	X5R	≤ 16V	C > 1.0μF	25V, 50V	C ≥ 1.0μF	X6S	6.3V, 10V	C > 1.0μF	16V, 25V	C ≥ 1.0μF	X7R/X7S/Y5V	6.3V, 10V	C ≥ 1.0μF	0603	X5R/X7R/ X6S/X7S	4V	C ≥ 22μF	6.3V, 10V	C ≥ 4.7μF <sup>1)</sup>	X5R/X6S/X7S	25V	C ≥ 1.0μF	X7R	35V	C ≥ 1.0μF	0805	X5R/X7R/ X6S/X7S	4V	C ≥ 47μF	6.3V	C ≥ 22μF	10V, 50V	C ≥ 10μF	X6S	16V	C > 10μF	25V	C ≥ 10μF	X7R/X7S	16V, 25V	C ≥ 10μF	1206	X5R/X7R/X6S	≤ 6.3V	C ≥ 47μF	1210	X5R/X7R/X6S	16V	C ≥ 47μF	X7R	100V	C ≥ 3.3μF	<p>**1VV items must follow de-rating conditions. #1. 0603X106(10V)&amp;0603S106(4V&amp;6.3V): 150% of rated voltage 2) 150% of rated voltage for below range.</p> <table border="1"> <thead> <tr> <th>Size</th> <th>Dielectric</th> <th>Rated voltage</th> <th>Capacitance</th> </tr> </thead> <tbody> <tr> <td rowspan="2">0201</td> <td rowspan="2">X5R/X6S</td> <td>16V, 25V</td> <td>C = 0.1μF</td> </tr> <tr> <td>X7R</td> <td>16V</td> <td>C ≥ 0.022μF</td> </tr> <tr> <td rowspan="2">0402</td> <td rowspan="2">X7R/X5R/ X6S</td> <td>50V</td> <td>C &gt; 0.01μF</td> </tr> <tr> <td>10~25V</td> <td>C ≥ 0.22μF</td> </tr> <tr> <td rowspan="5">0603</td> <td rowspan="2">X7S</td> <td>50V~100V</td> <td>C &gt; 0.22μF</td> </tr> <tr> <td rowspan="3">X7R</td> <td>50V</td> <td>C &gt; 0.1μF</td> </tr> <tr> <td>25V</td> <td>C = 1.0μF</td> </tr> <tr> <td>X5R</td> <td>50V</td> <td>C ≥ 1.0μF</td> </tr> <tr> <td>X5R/X7R/ X6S/X7S</td> <td>10V, 16V</td> <td>C ≥ 1.0μF</td> </tr> <tr> <td rowspan="4">0805</td> <td rowspan="2">X5R/X7R/ X6S/X7S</td> <td>100V</td> <td>C ≥ 0.47μF</td> </tr> <tr> <td>50V</td> <td>C ≥ 0.68μF</td> </tr> <tr> <td rowspan="2">X7R</td> <td>35V</td> <td>C ≥ 2.2μF</td> </tr> <tr> <td>10~25V</td> <td>C ≥ 4.7μF</td> </tr> <tr> <td rowspan="3">1206</td> <td rowspan="2">X7R</td> <td>100V</td> <td>C ≥ 1.0μF</td> </tr> <tr> <td>50V</td> <td>C ≥ 2.2μF</td> </tr> <tr> <td>X5R/X6S/ X7S</td> <td>100V</td> <td>C &gt; 1.0μF</td> </tr> <tr> <td rowspan="2">1210</td> <td rowspan="2">X5R/X7R/ X6S/X7S</td> <td>50V</td> <td>C &gt; 4.7μF</td> </tr> <tr> <td>50V~100V</td> <td>C ≥ 2.2μF</td> </tr> <tr> <td>1825 2220 2225</td> <td rowspan="2">X7R</td> <td>100V~250V</td> <td>C ≥ 1.0μF</td> </tr> </tbody> </table>	Size	Dielectric	Rated voltage	Capacitance	0201	X5R/X6S	16V, 25V	C = 0.1μF	X7R	16V	C ≥ 0.022μF	0402	X7R/X5R/ X6S	50V	C > 0.01μF	10~25V	C ≥ 0.22μF	0603	X7S	50V~100V	C > 0.22μF	X7R	50V	C > 0.1μF	25V	C = 1.0μF	X5R	50V	C ≥ 1.0μF	X5R/X7R/ X6S/X7S	10V, 16V	C ≥ 1.0μF	0805	X5R/X7R/ X6S/X7S	100V	C ≥ 0.47μF	50V	C ≥ 0.68μF	X7R	35V	C ≥ 2.2μF	10~25V	C ≥ 4.7μF	1206	X7R	100V	C ≥ 1.0μF	50V	C ≥ 2.2μF	X5R/X6S/ X7S	100V	C > 1.0μF	1210	X5R/X7R/ X6S/X7S	50V	C > 4.7μF	50V~100V	C ≥ 2.2μF	1825 2220 2225	X7R	100V~250V	C ≥ 1.0μF
		Size	Dielectric	Rated voltage	Capacitance																																																																																																																											
		0201	X5R/X7R/ X6S/X7S	≤ 10V	C ≥ 0.1μF																																																																																																																											
				≥ 16V	C > 0.1μF																																																																																																																											
		0402	X5R	≤ 16V	C > 1.0μF																																																																																																																											
				25V, 50V	C ≥ 1.0μF																																																																																																																											
			X6S	6.3V, 10V	C > 1.0μF																																																																																																																											
				16V, 25V	C ≥ 1.0μF																																																																																																																											
		X7R/X7S/Y5V	6.3V, 10V	C ≥ 1.0μF																																																																																																																												
		0603	X5R/X7R/ X6S/X7S	4V	C ≥ 22μF																																																																																																																											
				6.3V, 10V	C ≥ 4.7μF <sup>1)</sup>																																																																																																																											
			X5R/X6S/X7S	25V	C ≥ 1.0μF																																																																																																																											
				X7R	35V	C ≥ 1.0μF																																																																																																																										
		0805	X5R/X7R/ X6S/X7S	4V	C ≥ 47μF																																																																																																																											
				6.3V	C ≥ 22μF																																																																																																																											
				10V, 50V	C ≥ 10μF																																																																																																																											
			X6S	16V	C > 10μF																																																																																																																											
				25V	C ≥ 10μF																																																																																																																											
		X7R/X7S	16V, 25V	C ≥ 10μF																																																																																																																												
		1206	X5R/X7R/X6S	≤ 6.3V	C ≥ 47μF																																																																																																																											
		1210	X5R/X7R/X6S	16V	C ≥ 47μF																																																																																																																											
				X7R	100V	C ≥ 3.3μF																																																																																																																										
		Size	Dielectric	Rated voltage	Capacitance																																																																																																																											
		0201	X5R/X6S	16V, 25V	C = 0.1μF																																																																																																																											
X7R	16V			C ≥ 0.022μF																																																																																																																												
0402	X7R/X5R/ X6S	50V	C > 0.01μF																																																																																																																													
		10~25V	C ≥ 0.22μF																																																																																																																													
0603	X7S	50V~100V	C > 0.22μF																																																																																																																													
		X7R	50V	C > 0.1μF																																																																																																																												
	25V		C = 1.0μF																																																																																																																													
	X5R		50V	C ≥ 1.0μF																																																																																																																												
	X5R/X7R/ X6S/X7S	10V, 16V	C ≥ 1.0μF																																																																																																																													
0805	X5R/X7R/ X6S/X7S	100V	C ≥ 0.47μF																																																																																																																													
		50V	C ≥ 0.68μF																																																																																																																													
	X7R	35V	C ≥ 2.2μF																																																																																																																													
		10~25V	C ≥ 4.7μF																																																																																																																													
1206	X7R	100V	C ≥ 1.0μF																																																																																																																													
		50V	C ≥ 2.2μF																																																																																																																													
	X5R/X6S/ X7S	100V	C > 1.0μF																																																																																																																													
1210	X5R/X7R/ X6S/X7S	50V	C > 4.7μF																																																																																																																													
		50V~100V	C ≥ 2.2μF																																																																																																																													
1825 2220 2225	X7R	100V~250V	C ≥ 1.0μF																																																																																																																													
<table border="1"> <thead> <tr> <th>Rated voltage</th> <th>Insulation Resistance</th> </tr> </thead> <tbody> <tr> <td>100V: All X7R; 1210 ≥ 3.3μF</td> <td rowspan="10">1GΩ or RxC ≥ 10 Ω-F whichever is smaller.</td> </tr> <tr> <td>50V: 0402 &gt; 0.01μF; 0603 ≥ 1μF; 0805 ≥ 1μF; 1206 ≥ 4.7μF; 1210 ≥ 4.7μF</td> </tr> <tr> <td>35V: 0603 ≥ 1μF; 0805 ≥ 2.2μF; 1206 ≥ 2.2μF; 1210 ≥ 10μF</td> </tr> <tr> <td>25V: 0201 ≥ 0.1μF; 0402 ≥ 0.22μF; 0603 ≥ 2.2μF; 0805 ≥ 2.2μF; 1206 ≥ 10μF; 1210 ≥ 10μF</td> </tr> <tr> <td>16V: 0201 ≥ 0.1μF; 0402 ≥ 0.22μF; 0603 ≥ 1μF; 0805 ≥ 2.2μF; 1206 ≥ 10μF; 1210 ≥ 47μF</td> </tr> <tr> <td>10V: 0201 ≥ 47nF; 0402 ≥ 0.47μF; 0603 ≥ 0.47μF; 0805 ≥ 2.2μF; 1206 ≥ 4.7μF; 1210 ≥ 47μF</td> </tr> <tr> <td>6.3V; 4V; TT series; All X6S/X7S items; Size ≥ 1812</td> </tr> </tbody> </table>		Rated voltage	Insulation Resistance	100V: All X7R; 1210 ≥ 3.3μF	1GΩ or RxC ≥ 10 Ω-F whichever is smaller.	50V: 0402 > 0.01μF; 0603 ≥ 1μF; 0805 ≥ 1μF; 1206 ≥ 4.7μF; 1210 ≥ 4.7μF	35V: 0603 ≥ 1μF; 0805 ≥ 2.2μF; 1206 ≥ 2.2μF; 1210 ≥ 10μF	25V: 0201 ≥ 0.1μF; 0402 ≥ 0.22μF; 0603 ≥ 2.2μF; 0805 ≥ 2.2μF; 1206 ≥ 10μF; 1210 ≥ 10μF	16V: 0201 ≥ 0.1μF; 0402 ≥ 0.22μF; 0603 ≥ 1μF; 0805 ≥ 2.2μF; 1206 ≥ 10μF; 1210 ≥ 47μF	10V: 0201 ≥ 47nF; 0402 ≥ 0.47μF; 0603 ≥ 0.47μF; 0805 ≥ 2.2μF; 1206 ≥ 4.7μF; 1210 ≥ 47μF	6.3V; 4V; TT series; All X6S/X7S items; Size ≥ 1812																																																																																																																					
Rated voltage	Insulation Resistance																																																																																																																															
100V: All X7R; 1210 ≥ 3.3μF	1GΩ or RxC ≥ 10 Ω-F whichever is smaller.																																																																																																																															
50V: 0402 > 0.01μF; 0603 ≥ 1μF; 0805 ≥ 1μF; 1206 ≥ 4.7μF; 1210 ≥ 4.7μF																																																																																																																																
35V: 0603 ≥ 1μF; 0805 ≥ 2.2μF; 1206 ≥ 2.2μF; 1210 ≥ 10μF																																																																																																																																
25V: 0201 ≥ 0.1μF; 0402 ≥ 0.22μF; 0603 ≥ 2.2μF; 0805 ≥ 2.2μF; 1206 ≥ 10μF; 1210 ≥ 10μF																																																																																																																																
16V: 0201 ≥ 0.1μF; 0402 ≥ 0.22μF; 0603 ≥ 1μF; 0805 ≥ 2.2μF; 1206 ≥ 10μF; 1210 ≥ 47μF																																																																																																																																
10V: 0201 ≥ 47nF; 0402 ≥ 0.47μF; 0603 ≥ 0.47μF; 0805 ≥ 2.2μF; 1206 ≥ 4.7μF; 1210 ≥ 47μF																																																																																																																																
6.3V; 4V; TT series; All X6S/X7S items; Size ≥ 1812																																																																																																																																
<p>(3) ≤ 6.3V or C ≥ 10μF: 150% of rated voltage. (4) 10V~250V: 200% of rated voltage. (5) 400V~450V: 120% of rated voltage. (6) 500V: 150% of rated voltage. (7) 630V~3000V: 120% of rated voltage, Excluding 1210/X7R/103/2KV (110% of rated voltage) &amp; 1812N472&amp;1812N562(1KV): 100% of rated voltage. (8) 4000V: 110% of rated voltage * Before initial measurement (Class II only): To apply de-aging at 150°C for 1hr then set for 24±2 hrs at room temp. Cap. / DF(Q) / I.R. Measurement to be made after de-aging at 150°C for 1hr then set for 24±2 hrs at room temp. * De-rating conditions:</p>																																																																																																																																

\* "Room condition" Temperature: 15 to 35°C, Relative humidity: 25 to 75%, Atmospheric pressure: 86 to 106kPa.



Multilayer Ceramic Capacitors

APPENDIXES

■ Tape & reel dimensions

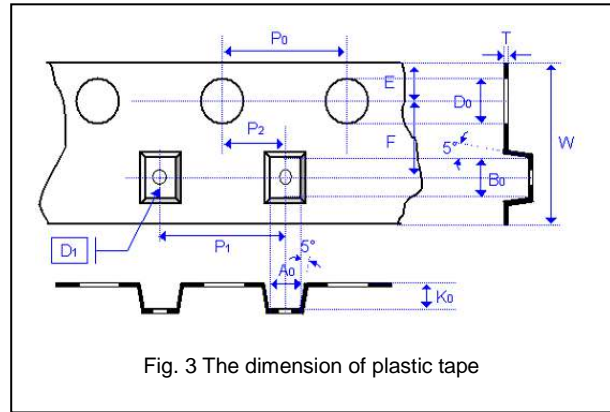
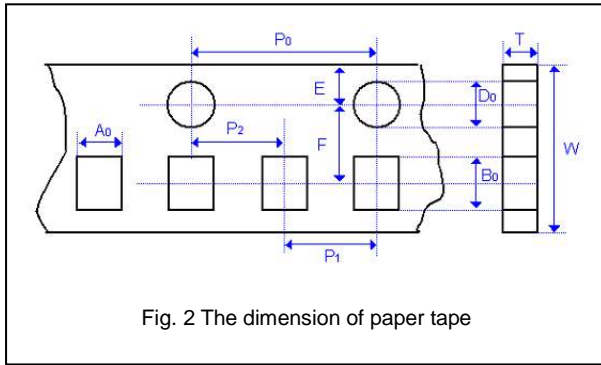

Size	0402	0603	0805			1206			1210	1808	1812	1825		2220		2225	
Thickness	N,E	S,X	A,H	B,T	D,I	B,T	C,J,D	G,P	C,D,G,K	M	D,F,G,K	D,F,G,K	M,U	K	M,U	K	M,U
A <sub>0</sub>	0.70 +/-0.20	1.05 +/-0.30	1.50 +/-0.20	1.50 +/-0.20	< 1.80	1.90 +/-0.50	< 2.00	< 2.30	< 3.05	< 3.20	< 2.50	< 3.90	< 3.90	< 6.80	< 6.80	< 5.80	< 5.80
B <sub>0</sub>	1.20 +/-0.20	1.80 +/-0.30	2.30 +/-0.20	2.30 +/-0.20	< 2.70	3.50 +/-0.50	< 3.70	< 4.00	< 3.80	< 4.00	< 5.30	< 5.30	< 5.30	< 5.30	< 5.30	< 6.50	< 6.50
T	≤ 0.80	≤ 1.20	≤ 1.15	≤ 1.20	0.23 +/-0.1	≤ 1.20	0.23 +/-0.1	0.23 +/-0.1	0.23 +/-0.1	0.23 +/-0.1	0.25 +/-0.1	0.25 +/-0.1	0.25 +/-0.1	0.30	0.30	0.30	0.30
K <sub>0</sub>	-	-	-	-	< 2.50	< 2.50	< 2.50	< 2.50	< 2.50	< 3.20	< 2.50	< 2.50	< 3.50	< 2.50	< 3.50	< 2.50	< 3.50
W	8.00 +/-0.30	8.00 +/-0.30	8.00 +/-0.30	8.00 +/-0.30	8.00 +/-0.30	8.00 +/-0.30	8.00 +/-0.30	8.00 +/-0.30	8.00 +/-0.30	8.00 +/-0.30	12.00 +/-0.30	12.00 +/-0.30	12.00 +/-0.30	12.00 +/-0.30	12.00 +/-0.30	12.00 +/-0.30	12.00 +/-0.30
P <sub>0</sub>	4.00 +/-0.10	4.00 +/-0.10	4.00 +/-0.10	4.00 +/-0.10	4.00 +/-0.10	4.00 +/-0.10	4.00 +/-0.10	4.00 +/-0.10	4.00 +/-0.10	4.00 +/-0.10	4.00 +/-0.10	4.00 +/-0.10	4.00 +/-0.10	4.00 +/-0.10	4.00 +/-0.10	4.00 +/-0.10	4.00 +/-0.10
10xP <sub>0</sub>	40.00 +/-0.10	40.00 +/-0.20	40.00 +/-0.20	40.00 +/-0.20	40.00 +/-0.20	40.00 +/-0.20	40.00 +/-0.20	40.00 +/-0.20	40.00 +/-0.20	40.00 +/-0.20	40.00 +/-0.20	40.00 +/-0.20	40.00 +/-0.20	40.00 +/-0.20	40.00 +/-0.20	40.00 +/-0.20	40.00 +/-0.20
P <sub>1</sub>	2.00 +/-0.05	4.00 +/-0.10	4.00 +/-0.10	4.00 +/-0.10	4.00 +/-0.10	4.00 +/-0.10	4.00 +/-0.10	4.00 +/-0.10	4.00 +/-0.10	4.00 +/-0.10	4.00 +/-0.10	8.00 +/-0.10	8.00 +/-0.10	8.00 +/-0.10	8.00 +/-0.10	8.00 +/-0.10	8.00 +/-0.10
P <sub>2</sub>	2.00 +/-0.05	2.00 +/-0.05	2.00 +/-0.05	2.00 +/-0.05	2.00 +/-0.05	2.00 +/-0.05	2.00 +/-0.05	2.00 +/-0.05	2.00 +/-0.05	2.00 +/-0.05	2.00 +/-0.10	2.00 +/-0.10	2.00 +/-0.10	2.00 +/-0.10	2.00 +/-0.10	2.00 +/-0.10	2.00 +/-0.10
D <sub>0</sub>	1.50 +0.1/-0	1.50 +0.1/-0	1.50 +0.1/-0	1.50 +0.1/-0	1.50 +0.1/-0	1.50 +0.1/-0	1.50 +0.1/-0	1.50 +0.1/-0	1.50 +0.1/-0	1.50 +0.1/-0	1.50 +0.1/-0	1.50 +0.1/-0	1.50 +0.1/-0	1.50 +0.1/-0	1.50 +0.1/-0	1.50 +0.1/-0	1.50 +0.1/-0
D <sub>1</sub>	-	-	-	-	1.00 +/-0.10	1.00 +/-0.10	1.00 +/-0.10	1.00 +/-0.10	1.00 +/-0.10	1.00 +/-0.10	1.50 +/-0.10	1.50 +/-0.10	1.50 +/-0.10	1.50 +/-0.10	1.50 +/-0.10	1.50 +/-0.10	1.50 +/-0.10
E	1.75 +/-0.10	1.75 +/-0.10	1.75 +/-0.10	1.75 +/-0.10	1.75 +/-0.10	1.75 +/-0.10	1.75 +/-0.10	1.75 +/-0.10	1.75 +/-0.10	1.75 +/-0.10	1.75 +/-0.10	1.75 +/-0.10	1.75 +/-0.10	1.75 +/-0.10	1.75 +/-0.10	1.75 +/-0.10	1.75 +/-0.10
F	3.50 +/-0.05	3.50 +/-0.05	3.50 +/-0.05	3.50 +/-0.05	3.50 +/-0.05	3.50 +/-0.05	3.50 +/-0.05	3.50 +/-0.05	3.50 +/-0.05	3.50 +/-0.05	5.50 +/-0.10	5.50 +/-0.10	5.50 +/-0.10	5.50 +/-0.10	5.50 +/-0.10	5.50 +/-0.10	5.50 +/-0.10

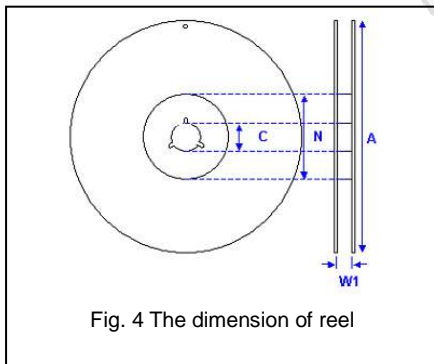

Size	0402, 0603, 0805, 1206, 1210			1808 to 2225
Reel size	7"	10"	13"	7"
C	13.0±0.5	13.0±0.5	13.0±0.5	13.0±0.5
W <sub>1</sub>	10.0±1.5	10.0±1.5	10.0±1.5	12.4+2.0/-0
A	178.0±2.0	250.0±2.0	330.0±2.0	178.0±2.0
N	60.0+1.0/-0	50 min	50 min	60.0+1.0/-0

■ Peeling force (EIA-481)

Peel-off force should be in the range of 10 grams to 100 grams at a peel-off speed of 300±10 mm/min.

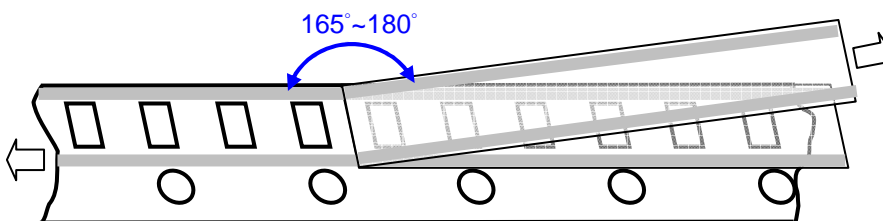

Multilayer Ceramic Capacitors

Example of customer label

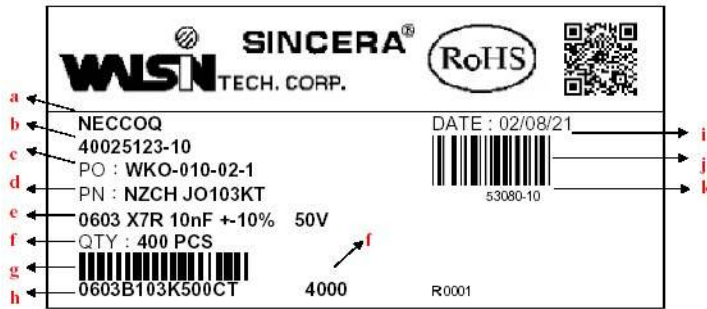

- a. Customer name
- b. WTC order series and item number
- c. Customer P/O
- d. Customer P/N
- e. Description of product
- f. Quantity
- g. Bar code including quantity & WTC P/N or customer
- h. WTC P/N
- i. Shipping date
- j. Order bar code including series and item numbers
- k. Serial number of label

\*Customized label is available upon request

Constructions

No.	Name	NPO	X7R, X5R, Y5V
①	Ceramic material	CaZrO <sub>3</sub> based	BaTiO <sub>3</sub> based
②	Inner electrode	Ni	
③	Termination	Inner layer	Cu + Ag Polymer
④		Middle layer	Ni
⑤		Outer layer	Sn

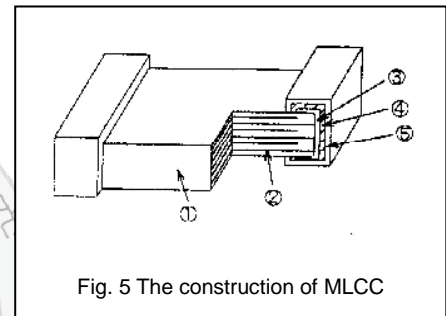

Fig. 5 The construction of MLCC

Storage and handling conditions

- (1) To store products at 5 to 40°C ambient temperature and 20 to 70% related humidity conditions; MSL Level 1.
- (2) The product is recommended to be used within one year after shipment. Check solderability in case of shelf life extension is needed.

Cautions:

- a. The corrosive gas reacts on the terminal electrodes of capacitors, and results in the poor solderability. Do not store the capacitors in the ambience of corrosive gas (e.g., hydrogen sulfide, sulfur dioxide, chlorine, ammonia gas etc.)
- b. In corrosive atmosphere, solderability might be degraded, and silver migration might occur to cause low reliability.
- c. Due to the dewing by rapid humidity change, or the photochemical change of the terminal electrode by direct sunlight, the solderability and electrical performance may deteriorate. Do not store capacitors under direct sunlight or dewing condition. To store products on the shelf and avoid exposure to moisture.

Caution for SOFT TERMINATION Products

Since the middle layer of the terminal electrode contains Ag (silver), when chip capacitors on printed circuit board (PCB), it should be protected by moisture proof-sealing to prevent electromigration of Ag under high temperature, high humidity and failure due to corrosive gas.

Multilayer Ceramic Capacitors

Recommended soldering conditions

The lead-free termination MLCCs are not only to be used on SMT against lead-free solder paste, but also suitable against lead-containing solder paste. If the optimized solder joint is requested, increasing soldering time, temperature and concentration of N<sub>2</sub> within oven are recommended.

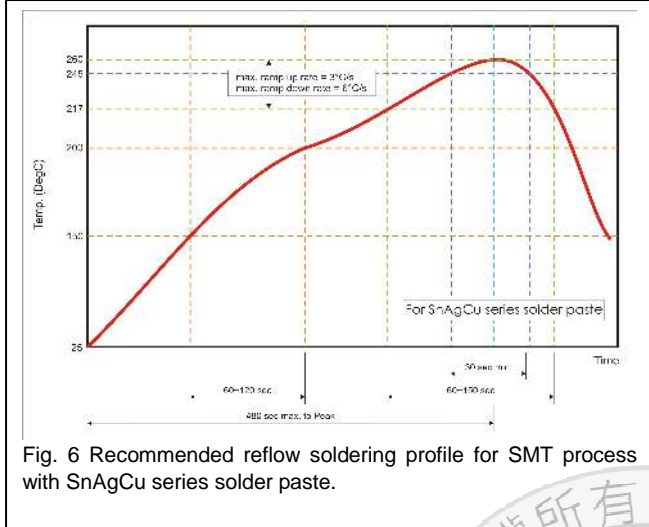

Fig. 6 Recommended reflow soldering profile for SMT process with SnAgCu series solder paste.

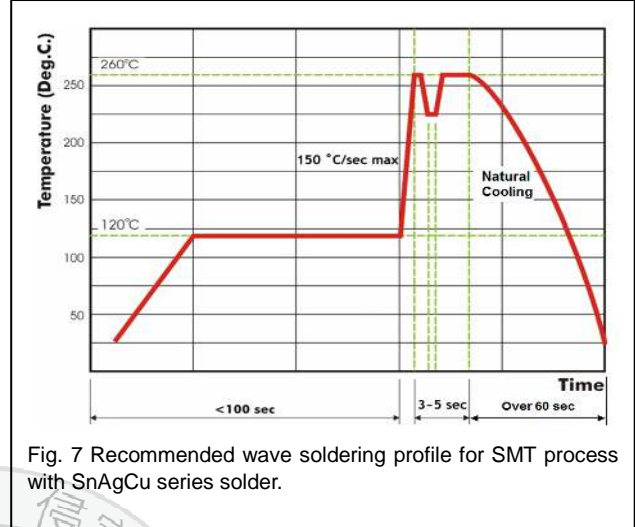

Fig. 7 Recommended wave soldering profile for SMT process with SnAgCu series solder.

