

PART NUMBER	REVISION	DESCRIPTION	FEED TYPE
2150184-2	D	FINE CRIMP HEIGHT ADJUST	PNEUMATIC
7-2150184-2	D	PNEUMATIC AND CRIMP TOOLING KIT	PNEUMATIC
7-2150184-7	A	CRIMP TOOLING KIT	-

ATLANTIC VERSION TERMINATOR INTERFACE ADAPTER

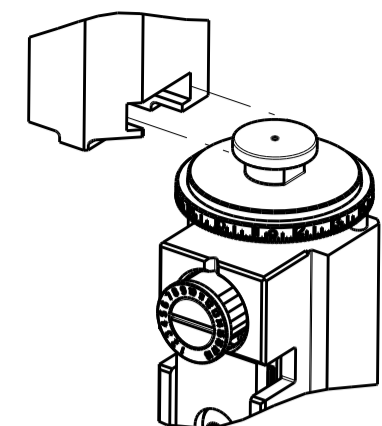

APPLICATOR DATA		
CRIMP	SIZE	TYPE
WIRE	2.29 mm [.090]	F
INSUL	3.56 mm [.140]	F
APPLICATOR INSTRUCTIONS 408-35043		

TERMINAL DATA: TE TERMINAL		TE CRIMP SPECIFICATION	
TERMINAL NAME: RECPT, POSITIVE-LOCK, .187 SERIES			
WIRE STRIP LENGTH		INSULATION DIAMETER RANGE	
4.40-5.16 mm [.173-.203 IN]		Ø1.52-2.79 mm [.060-.110 IN]	
TERMINAL APPLICATION SPECIFICATION	114-2074		
TERMINALS APPLIED			
TE TERMINAL	TE TERMINAL	TE TERMINAL	TE TERMINAL
63498-1	63498-2	63784-1	

WIRE SIZE	CRIMP HEIGHT mm [INCH]	CRIMP HEIGHT REFERENCE SETTING
16 AWG	1.45 +/- 0.05 [.057 +/- .002]	3.7
18 AWG	1.27 +/- 0.05 [.050 +/- .002]	5.8
0.75mm <sup>2</sup>	1.22 +/- 0.05 [.048 +/- .002]	6.5
20 AWG	1.14 +/- 0.05 [.045 +/- .002]	7.3



- RECOMMENDED SPARE PARTS
- REFER TO SUPPLIED INSTRUCTION SHEET FOR CLEANING, LUBRICATION AND STORAGE OF APPLICATOR.
- APPLY PART NUMBER 2-23419-6 LOCTITE TO THREADS OF ITEM 242. APPLY PART NUMBER 1-23419-5 LOCTITE TO THREADS OF ITEM 50.
- CRIMP HEIGHT REFERENCE SETTING WAS THE SETTING USED WHEN THE APPLICATOR WAS QUALIFIED AT THE FACTORY. ADJUSTMENT MAY BE NECESSARY WHEN RUNNING APPLICATOR IN THE FIELD.
- TERMINAL LUBRICANT IS RECOMMENDED.
- 6. UNLESS SPECIFIED OTHERWISE TORQUE VALUES SHALL BE USED PER DOCUMENT, 101-35000.
- TERMINAL PITCH NOT COMPATIBLE WITH MECHANICAL FEED.

**\*WARNING**  
 ON INSTALLATION, SET WIRE DISC TO CRIMP HEIGHT REFERENCE SETTING FOR LARGEST WIRE SIZE. CRIMP HEIGHT REFERENCE SETTINGS GREATER THAN THE VALUE SHOWN MAY CAUSE DAMAGE TO THE CRIMP TOOLING. REFER TO THE INSTRUCTION SHEET FOR PROPER SETUP AND ADJUSTMENTS.

**ATLANTIC VERSION**  
 Shown on sheets 1 of 4 & 2 of 4  
 (Pacific version shown on sheets 3 of 4 & 4 of 4)

LOC	DIST	REVISIONS					
		P	LTN	DESCRIPTION	DATE	OWN	APVD
A	66	B		ECR-17-013517	13SEP2017	TB	JDG
		C		ECR-19-005894	11APR2019	TB	CT
		D		ECR-20-015838	06NOV2020	FZ	RK

-	1	1	2119641-1	FEED CAM, AIR FEED	248	
-	1	1	2119082-9	CAM, SNAIL, INSULATION ADJUSTMENT	244	
-	1	1	2079764-1	WASHER, WAVE SPRING, CREST-TO-CREST	243	
-	1	1	2119083-1	RETAINER, INSULATION DIAL	242	
-	1	1	2844940-3	AIR FEED MODULE	238	
-	1	1	1-18028-0	WASHER, FLAT, REG M8	192	
-	1	1	6-993111-6	PIN, SLOTTED SPRING 3.0 X 14.0	177	
-	1	1	8-22280-7	SPRING, COMPRESSION	176	
-	1	1	1752353-2	GUIDE PIN,HOLDDOWN	175	
-	1	1	1901680-2	GUIDE PIN,HOLDDOWN	174	
-	REF	REF	994970-2	COUNTER, MAGNETIC	164	
-	1	1	2119955-2	ASSY, LUBRICATOR, END FEED	84	
-	1	1	455888-6	SPACER, CRIMPER	82	
-	1	1	1803607-4	DOCUMENTATION PACKAGE	71	
-	2	2	2-18032-2	SCR, SET, FLT PNT, M3 X 10.0	70	
-	1	1	2119740-1	TAG, IDENTIFICATION	67	
-	2	2	2168078-1	SCREW, DRIVE, RH, RoHS, 2 x .188	66	
-	1	1	1901681-9	HOLDDOWN, TERMINAL	65	
-	2	2	2168400-8	SHCS, LOW HEAD, RoHS, M4 X 16	64	
-	1	1	2168083-2	SCR, SKT HD CAP, RoHS, M4 X 8.0	60	
-	1	1	5-18022-5	SCR, HEX HD CAP, M4 X 6.0	59	
-	3	3	2168400-4	SHCS, LOW HEAD, RoHS, M4 X 8	57	
-	2	2	2168083-3	SCR, SKT HD CAP, RoHS, M4 X 12.0	56	
-	2	2	5018030-1	NUT, HEX, REG, RoHS, M3	54	
-	2	2	986965-8	NUT, LOCK, HEX, TORQUE (M4)	53	
-	1	1	1-5018030-0	NUT, HEX, REG, RoHS, M3.5	52	
-	1	1	2063961-1	FEED FINGER	51	
-	1	1	1752354-8	STANDOFF,HOLD-DOWN	50	
-	1	1	18023-9	SCR, SKT HD CAP M4 X 6.0	49	
-	1	1	2119655-5	APPLICATOR BASIC ASSEMBLY, EF	46	
-	1	1	1803517-1	RAM ASSEMBLY, EF ATLANTIC	44	
-	1	1	1803602-1	SCR, BHSC, RoHS (M8 X 25)	41	
-	7	7	1-18028-2	WASHER, FLAT, REG M4	33	
-	2	2	2168083-9	SCR, SKT HD CAP, RoHS, M4 X 20	31	
-	2	2	2168083-2	SCR, SKT HD CAP, RoHS, M4 X 8.0	29	
-	1	1	240639-1	STRIPPER (MACHINING)	27	
-	2	2	1-2168083-5	SCR, SKT HD CAP, RoHS, M4 X 30	25	
-	1	1	2-1752371-1	PLATE, STRIP GUIDE	24	
-	1	1	240825-4	PLATE, STRIP HOLD DOWN	23	
-	2	2	2-22281-3	SPRING, COMPRESSION	22	
-	1	1	1803292-4	DRAG	20	
-	2	2	1901259-4	GUIDE, LOWER STRIP	18	
-	4	4	1-2079383-1	SCR, BHSC, RoHS (M6 X 12)	17	
-	1	1	8-240641-6	SPACER	16	
-	1	1	1752360-1	SPACER,HOLD-DOWN	13	
-	1	1	240833-7	PLATE, REAR SHEAR	11	
-	-	-	-	-	10	
-	1	1	690482-5	PLATE, FRONT SHEAR	9	
-	1	2	1	2-1633383-4	ANVIL, COMBINATION	8
-	1	1	1	2217206-7	BLADE, SLUG	7
-	1	1	1	240641-3	SPACER	5
-	1	1	1	238011-2	BLOCK, CRIMPER SPACER	4
-	1	2	1	5-2119582-2	CRIMPER, INSULATION F PREMIUM	3
-	1	1	1	455888-4	SPACER, CRIMPER	2
-	1	2	1	4-456406-7	CRIMPER, WIRE PREMIUM	1
-	77	72	2	PART NO	DESCRIPTION	ITEM NO

DIMENSIONS:		TOLERANCES UNLESS OTHERWISE SPECIFIED:		DRAWING NO	
mm	0 PLC ±	1 PLC ±	2 PLC ±	3 PLC ±	4 PLC ±
	ANGLES	FINISH			
MATERIAL					
Customer Accessible Production Drawing		SCALE	1:1	SHEET	1 OF 4

LOC	DIST	REV	DATE	BY	APPV
A	66				
REVISIONS			DESCRIPTION	DATE	BY
			SEE SHEET 1		

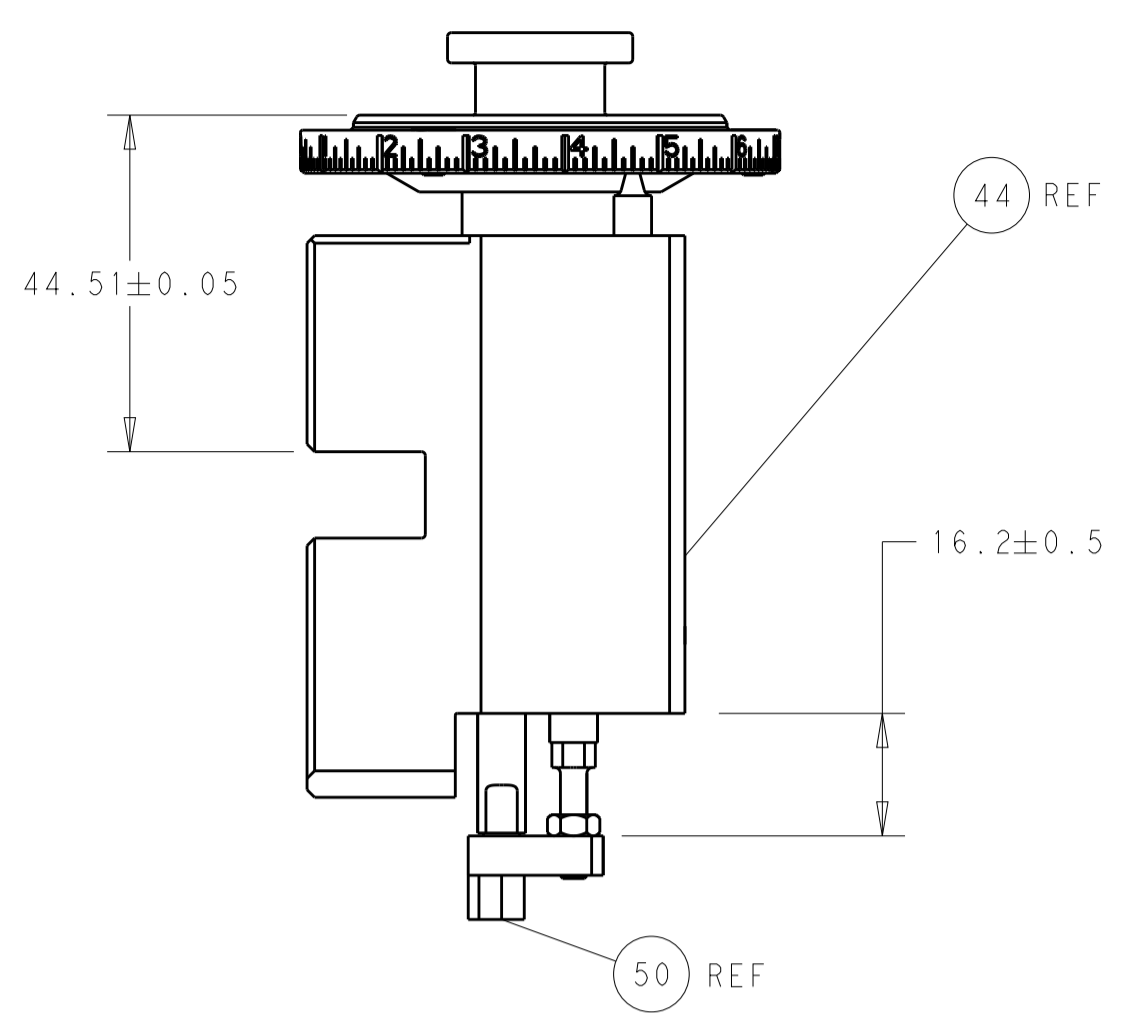

RAM AND HOLDDOWN SET-UP

FEED TYPE

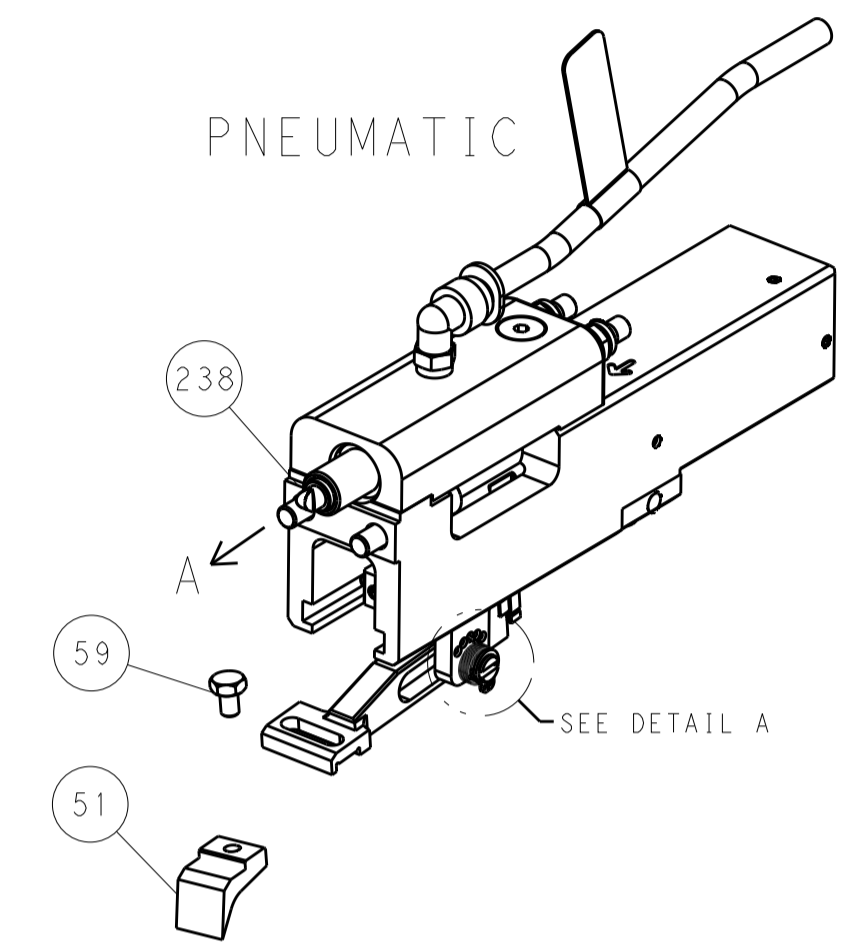

FEED SPRING SETTING POSITION

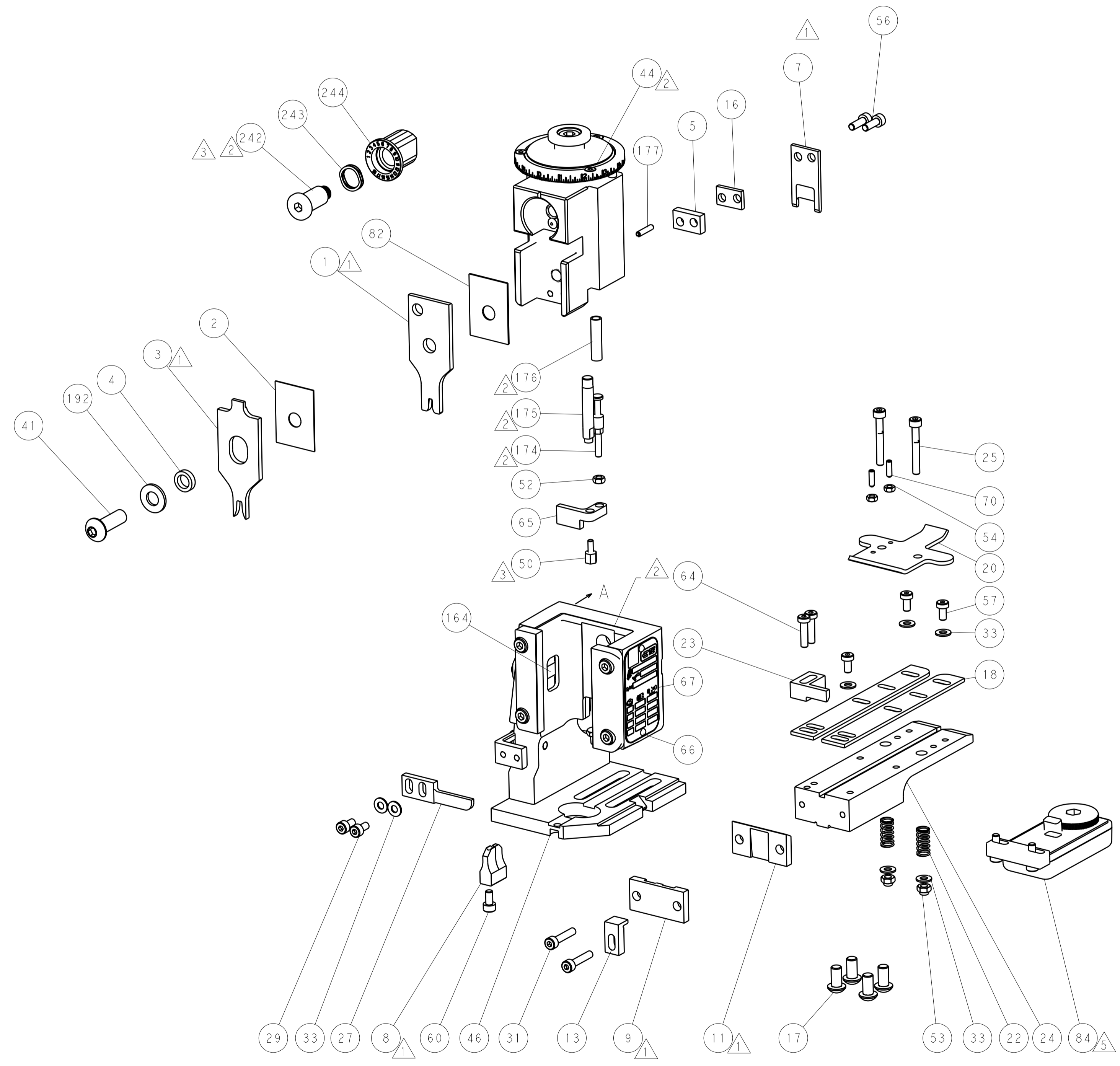
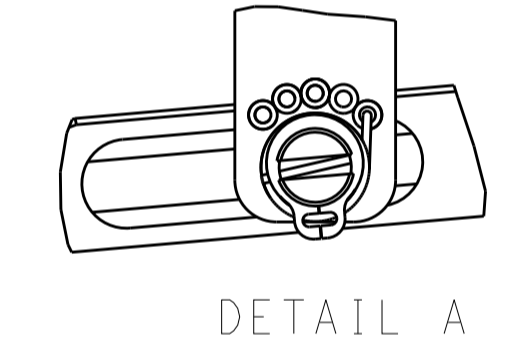

CAM POSITION

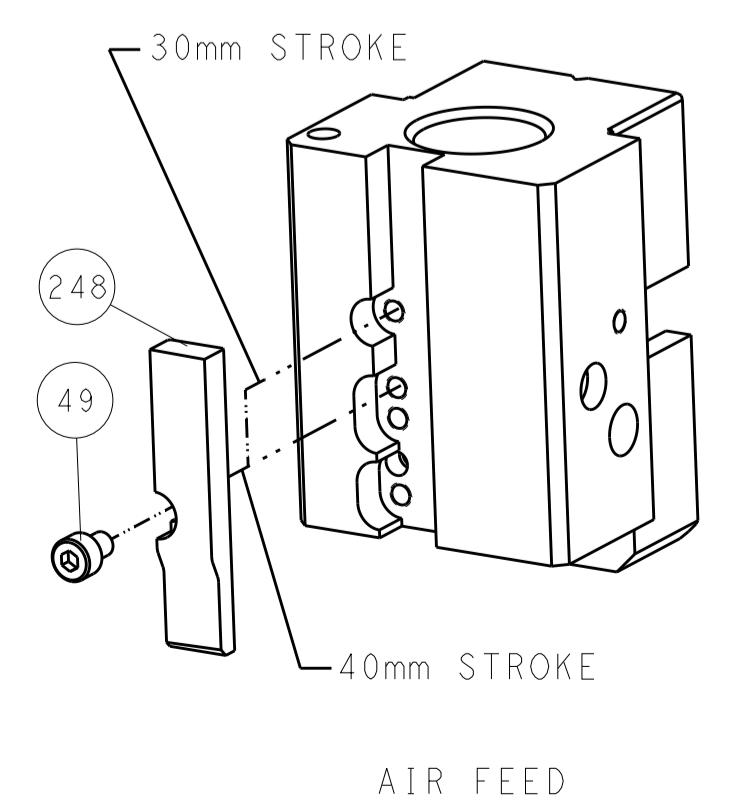

AIR FEED

ATLANTIC VERSION  
 Shown on sheets 1 of 4 & 2 of 4  
 (Pacific version shown on sheets 3 of 4 & 4 of 4)

DIMENSIONS: mm 		TOLERANCES UNLESS OTHERWISE SPECIFIED: 0 PLC ± 1 PLC ± 2 PLC ± 3 PLC ± 4 PLC ± ANGLES ±		DWN L. ZHANG 13SEP2012 CHK L. ZHANG 13SEP2012 APVD S. XI 13SEP2012		TE Connectivity Harrisburg, PA 17105-3608	
MATERIAL:		FINISH:		NAME: Ocean End Feed Applicator		RESTRICTED TO:	
WEIGHT:		SCALE: 1:1		SIZE: CAGE CODE: DRAWING NO: A11 00779 ©=2150184		SHEET 2 OF 4 REV D	

PART NUMBER	REVISION	DESCRIPTION	FEED TYPE
2-2150184-2	D	FINE CRIMP HEIGHT ADJUST	PNEUMATIC
7-2150184-7	A	CRIMP TOOLING KIT	-

PACIFIC VERSION TERMINATOR  
 INTERFACE ADAPTER

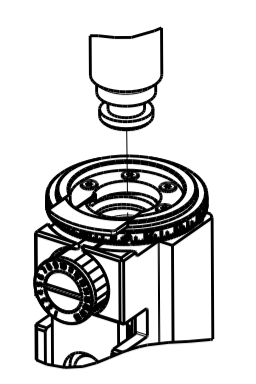

APPLICATOR DATA

CRIMP	SIZE	TYPE
WIRE	2.29 mm (.090)	F
INSUL	3.56 mm (.140)	F

APPLICATOR INSTRUCTIONS  
 408-35043

TERMINAL DATA: TE TERMINAL TE CRIMP SPECIFICATION

TERMINAL NAME: RECPT, POSITIVE-LOCK, .187 SERIES

WIRE STRIP LENGTH	INSULATION DIAMETER RANGE
4.40-5.16 mm (.173-.203 IN)	1.52-2.79 mm (.060-.110 IN)

TERMINAL APPLICATION SPECIFICATION  
 114-2074

TERMINALS APPLIED

TE TERMINAL	TE TERMINAL	TE TERMINAL	TE TERMINAL
63498-1	63498-2	63784-1	

WIRE SIZE	CRIMP HEIGHT mm [INCH]	CRIMP HEIGHT REFERENCE SETTING
16 AWG	1.45 +/- 0.05 [0.057 +/- .002]	3.7
18 AWG	1.27 +/- 0.05 [0.050 +/- .002]	5.8
0.75mm <sup>2</sup>	1.22 +/- 0.05 [0.048 +/- .002]	6.5
20 AWG	1.14 +/- 0.05 [0.045 +/- .002]	7.3

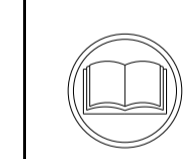

- RECOMMENDED SPARE PARTS
- REFER TO SUPPLIED INSTRUCTION SHEET FOR CLEANING, LUBRICATION AND STORAGE OF APPLICATOR.
- APPLY PART NUMBER 2-23419-6 LOCTITE TO THREADS OF ITEM 242. APPLY PART NUMBER 1-23419-5 LOCTITE TO THREADS OF ITEM 50.
- CRIMP HEIGHT REFERENCE SETTING WAS THE SETTING USED WHEN THE APPLICATOR WAS QUALIFIED AT THE FACTORY. ADJUSTMENT MAY BE NECESSARY WHEN RUNNING APPLICATOR IN THE FIELD.
- TERMINAL LUBRICANT IS RECOMMENDED.
- UNLESS SPECIFIED OTHERWISE TORQUE VALUES SHALL BE USED PER DOCUMENT, 101-35000.
- TERMINAL PITCH NOT COMPATIBLE WITH MECHANICAL FEED.

**\*WARNING**  
 ON INSTALLATION, SET WIRE DISC TO CRIMP HEIGHT REFERENCE SETTING FOR LARGEST WIRE SIZE. CRIMP HEIGHT REFERENCE SETTINGS GREATER THAN THE VALUE SHOWN MAY CAUSE DAMAGE TO THE CRIMP TOOLING. REFER TO THE INSTRUCTION SHEET FOR PROPER SETUP AND ADJUSTMENTS.

PACIFIC VERSION  
 Shown on sheets 3 of 4 & 4 of 4  
 (Atlantic version shown on sheets 1 of 4 & 2 of 4)

LOC	DIST	REV	DATE	BY	CHK	APP'D
A	66					

REV	DESCRIPTION	DATE	BY	CHK	APP'D
-	SEE SHEET 1				
-	1	2119082-9	CAM, SNAIL, INSULATION ADJUSTMENT		244
-	1	2079764-1	WASHER, WAVE SPRING, CREST-TO-CREST		243
-	1	2119083-1	RETAINER, INSULATION DIAL		242
-	1	2844940-3	AIR FEED MODULE		238
-	1	1-18028-0	WASHER, FLAT, REG M8		192
-	4	2079383-9	SCR, BHSC, RoHS (M6 X 20)		186
-	1	6-993111-6	PIN, SLOTTED SPRING 3.0 X 14.0		177
-	1	8-22280-7	SPRING, COMPRESSION		176
-	1	1752353-2	GUIDE PIN, HOLDDOWN		175
-	1	1901680-2	GUIDE PIN, HOLDDOWN		174
-	REF	994970-2	COUNTER, MAGNETIC		164
-	1	2119641-2	FEED CAM, AIR FEED		152
-	1	2168083-8	SCR, SKT HD CAP, RoHS, M4 X 16		144
-	1	2119655-6	APPLICATOR BASIC ASSEMBLY, EF		141
-	1	1803518-1	RAM ASSEMBLY, EF PACIFIC		140
-	1	2119955-2	ASSY, LUBRICATOR, END FEED		84
-	1	455888-6	SPACER, CRIMPER		82
-	1	1803607-4	DOCUMENTATION PACKAGE		71
-	2	2-18032-2	SCR, SET, FLT PNT, M3 X 10.0		70
-	1	2119740-1	TAG, IDENTIFICATION		67
-	2	2168078-1	SCREW, DRIVE, RH, RoHS, 2 x .188		66
-	1	1901681-9	HOLDDOWN, TERMINAL		65
-	2	2168400-8	SHCS, LOW HEAD, RoHS, M4 X 16		64
-	1	5-18022-5	SCR, HEX HD CAP, M4 X 6.0		59
-	3	2168400-4	SHCS, LOW HEAD, RoHS, M4 X 8		57
-	2	2168083-3	SCR, SKT HD CAP, RoHS, M4 X 12.0		56
-	2	5018030-1	NUT, HEX, REG, RoHS, M3		54
-	2	986965-8	NUT, LOCK, HEX, TORQUE (M4)		53
-	1	1-5018030-0	NUT, HEX, REG, RoHS, M3.5		52
-	1	2063961-1	FEED FINGER		51
-	1	1752354-8	STANDOFF, HOLD-DOWN		50
-	1	18023-9	SCR, SKT HD CAP M4 X 6.0		49
-	1	1803602-1	SCR, BHSC, RoHS (M8 X 25)		41
-	7	1-18028-2	WASHER, FLAT, REG M4		33
-	2	2168083-9	SCR, SKT HD CAP, RoHS, M4 X 20		31
-	2	2168083-2	SCR, SKT HD CAP, RoHS, M4 X 8.0		29
-	1	240639-1	STRIPPER (MACHINING)		27
-	2	1-2168083-5	SCR, SKT HD CAP, RoHS, M4 X 30		25
-	1	2-1752371-1	PLATE, STRIP GUIDE		24
-	1	240825-4	PLATE, STRIP HOLD DOWN		23
-	2	2-22281-3	SPRING, COMPRESSION		22
-	1	1803292-4	DRAG		20
-	2	1901259-4	GUIDE, LOWER STRIP		18
-	1	8-240641-6	SPACER		16
-	1	1752360-1	SPACER, HOLD-DOWN		13
-	1	240833-7	PLATE, REAR SHEAR		11
-	-	-	-		10
-	1	690482-5	PLATE, FRONT SHEAR		9
1	1	2-1633383-4	ANVIL, COMBINATION		8
-	1	2217206-7	BLADE, SLUG		7
-	1	240641-3	SPACER		5
-	1	238011-2	BLOCK, CRIMPER SPACER		4
1	1	5-2119582-2	CRIMPER, INSULATION F PREMIUM		3
-	1	455888-4	SPACER, CRIMPER		2
1	1	4-456406-7	CRIMPER, WIRE PREMIUM		1

DIMENSIONS:	TOLERANCES UNLESS OTHERWISE SPECIFIED:	DATE	BY	CHK	APP'D	
mm	0 PLC ± 1 PLC ± 2 PLC ± 3 PLC ± 4 PLC ± ANGLES ± FINISH	13SEP2012	L. ZHANG	L. ZHANG	S. XI	
MATERIAL:		WEIGHT:	SCALE:	Customer Accessible Production Drawing		

**STE** TE Connectivity  
 Harrisburg, PA 17105-3608

NAME: Ocean End Feed Applicator

SIZE: A1 CAGE CODE: 00779 DRAWING NO: 2150184

SHEET 3 OF 4

LOC	DIST	REV	DATE	BY	APPV
A	66				

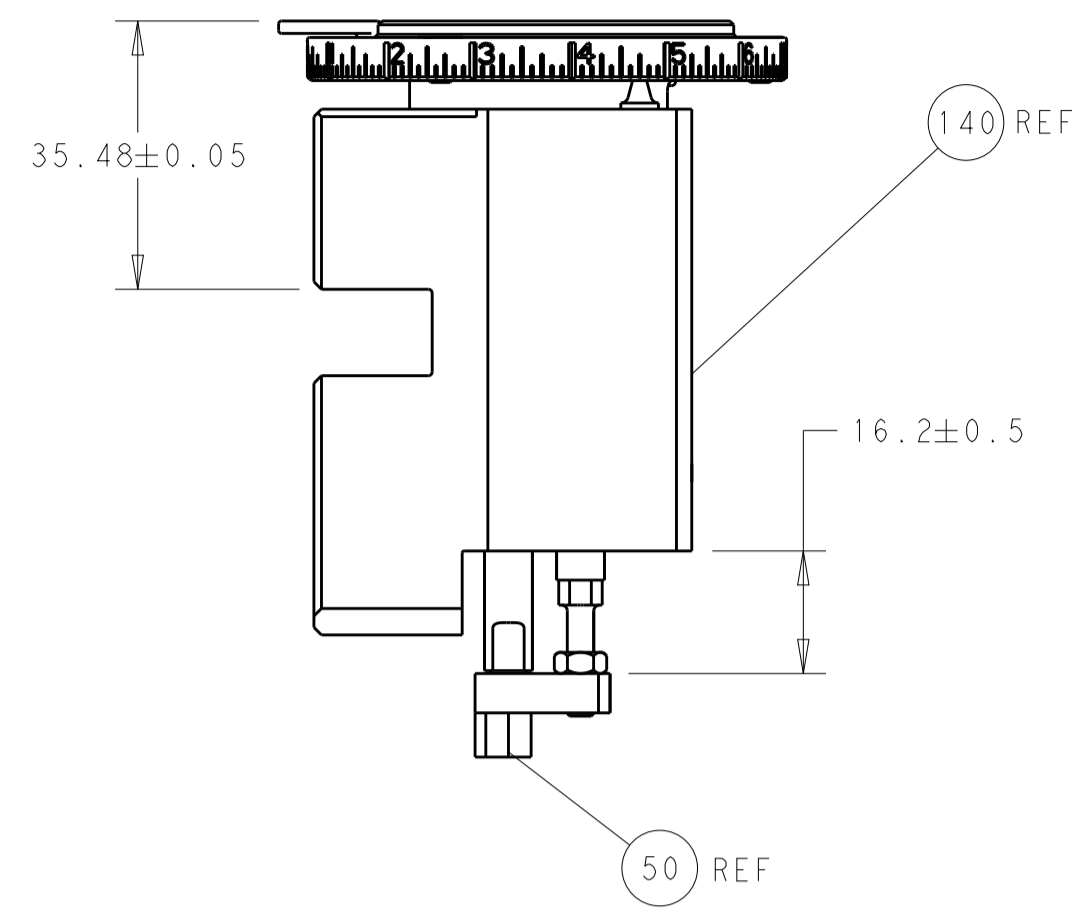

RAM AND HOLDDOWN SET-UP

FEED TYPE

PNEUMATIC

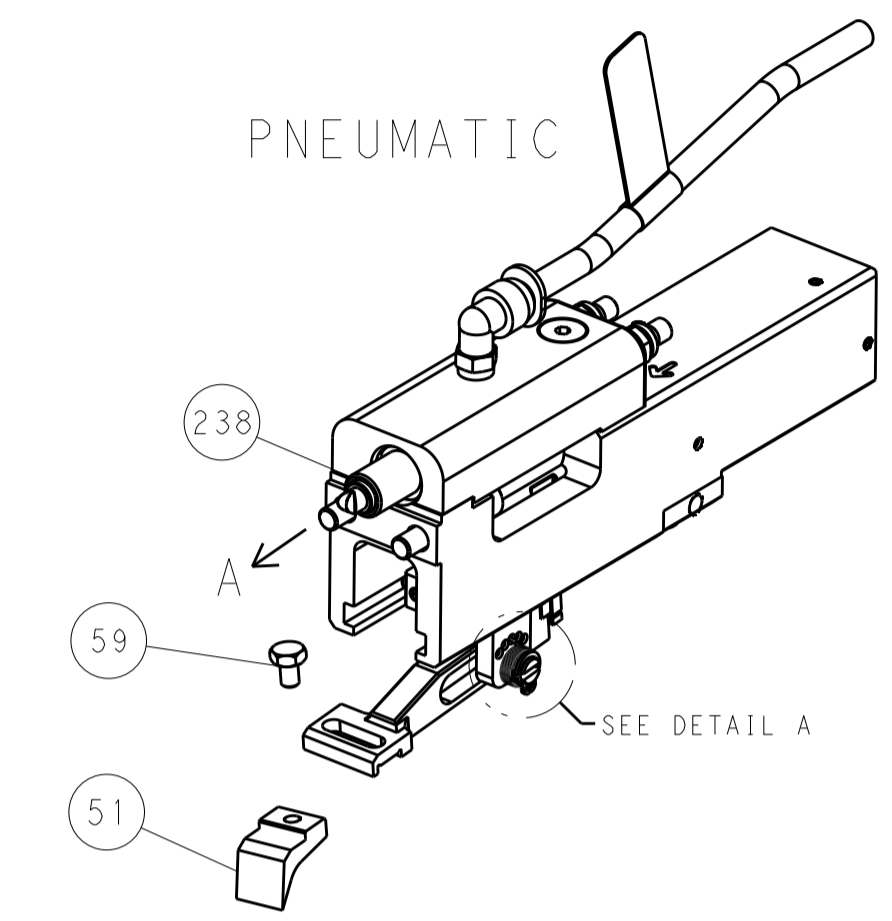

FEED SPRING SETTING POSITION

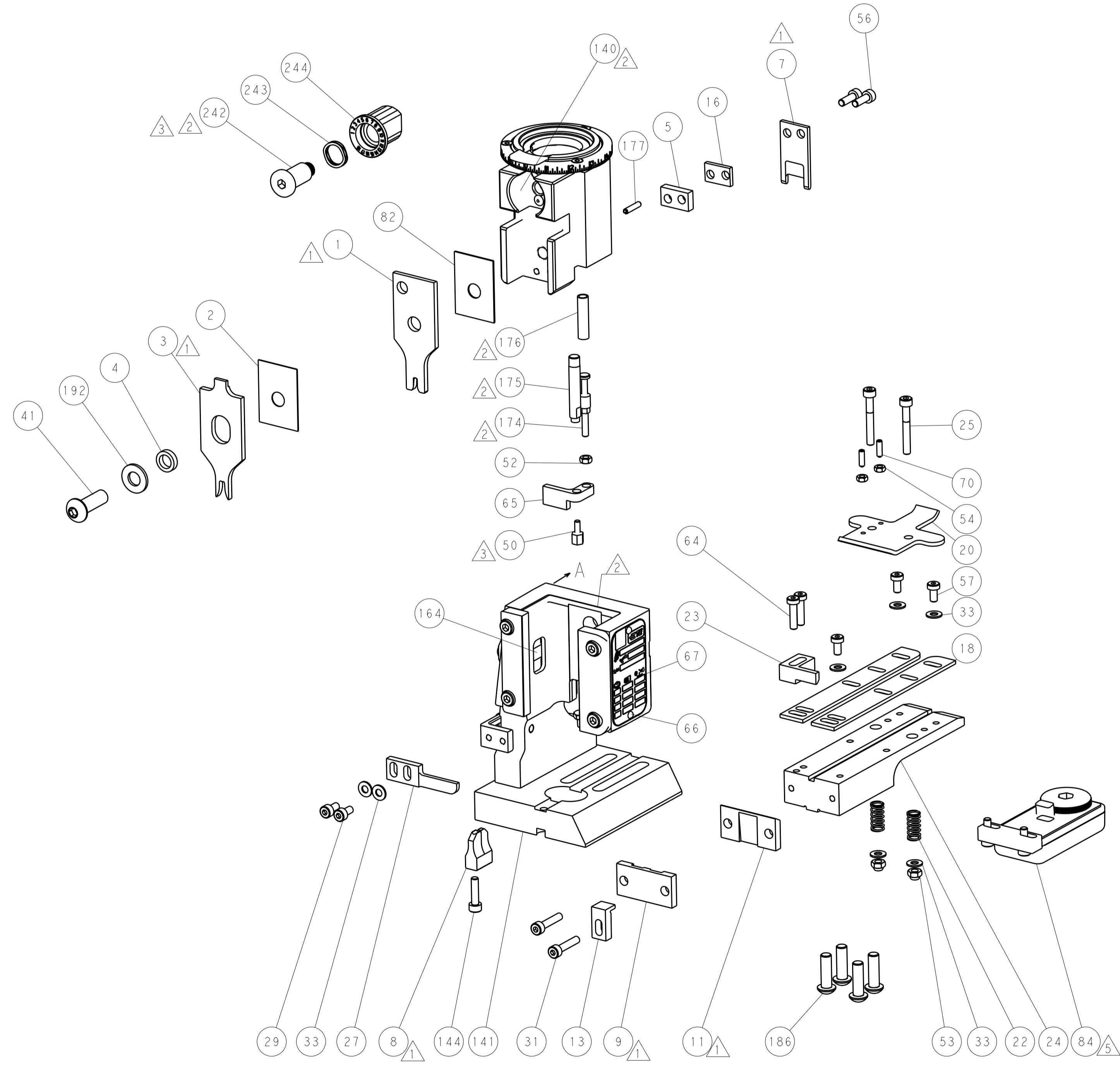
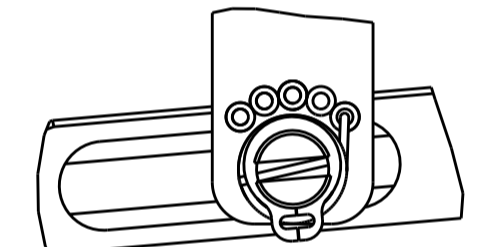

CAM POSITION

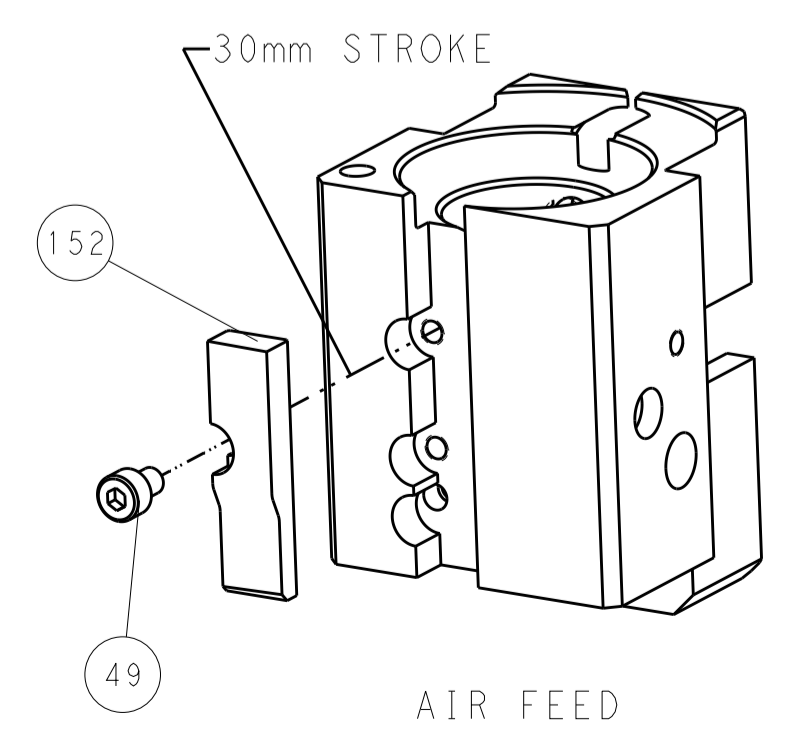

AIR FEED

PACIFIC VERSION  
 Shown on sheets 3 of 4 & 4 of 4  
 (Atlantic version shown on sheets 1 of 4 & 2 of 4)

<small>THIS DRAWING IS UNPUBLISHED. RELEASED FOR PUBLICATION BY TYCO ELECTRONICS CORPORATION. ALL RIGHTS RESERVED.</small>		DWN L. ZHANG 13SEP2012 CHK L. ZHANG 13SEP2012 APVD S. XI 13SEP2012	TE Connectivity Harrisburg, PA 17105-3608
DIMENSIONS: mm TOLERANCES UNLESS OTHERWISE SPECIFIED: 0 PLC ± 1 PLC ± 2 PLC ± 3 PLC ± 4 PLC ± ANGLES ±		NAME Ocean End Feed Applicator PRODUCT SPEC APPLICATION SPEC WEIGHT SCALE 1:1	RESTRICTED TO SIZE CAGE CODE DRAWING NO. A11 00779 C=2150184 SHEET 4 OF 4 REV D
MATERIAL: - FINISH: -		Customer Accessible Production Drawing	