

THIS DRAWING IS UNPUBLISHED. RELEASED FOR PUBLICATION 2011
 © COPYRIGHT 2011 ALL RIGHTS RESERVED.

LOC	DIST	REVISIONS					
GP	00	P	LTR	DESCRIPTION	DATE	DWN	APVD
		B		REDRAWN PER ECO-12-008266	27AUG2012	CJV	CWR
		C		REVISED PER ECO-13-007439	09JUL2013	CJV	CWR
		D		REVISED PER ECO-15-007873	14JUL2015	AP	SB

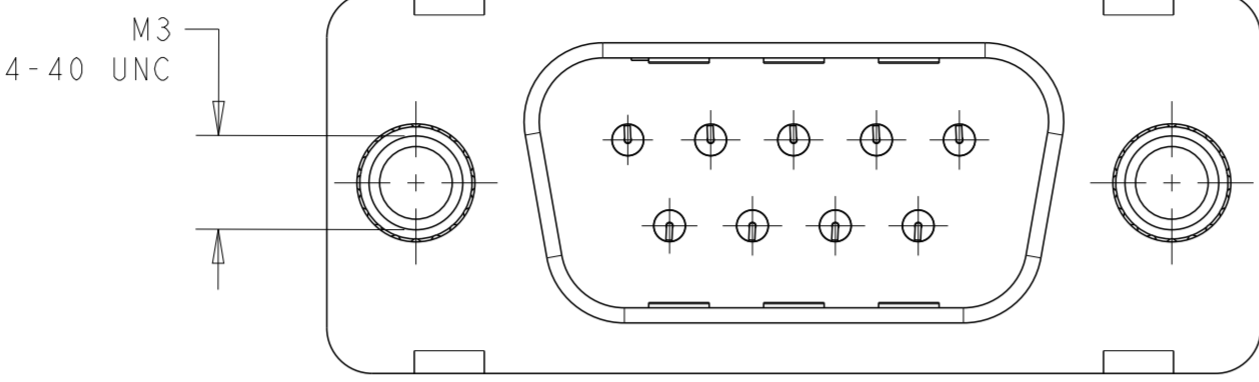

FLANGES WITH M3 OR 4-40 SELF-LOCKING NUTS TORQUE RETENTION ≥ 80NCM

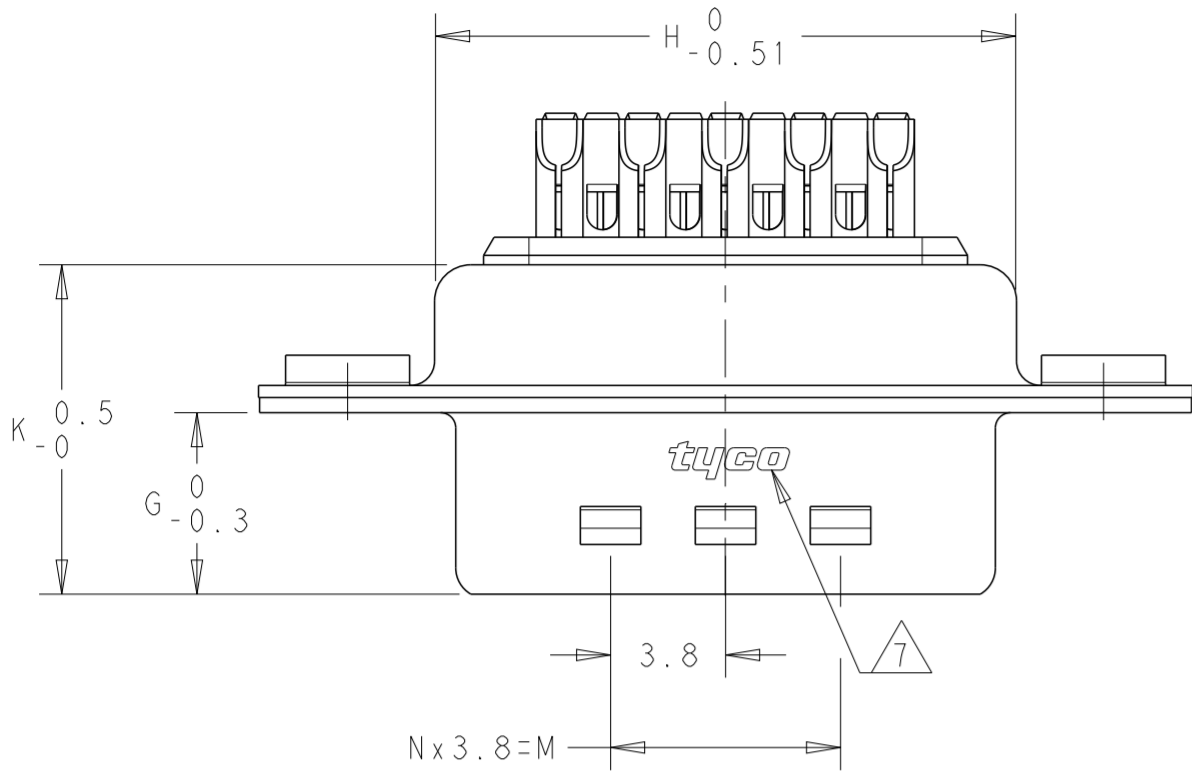
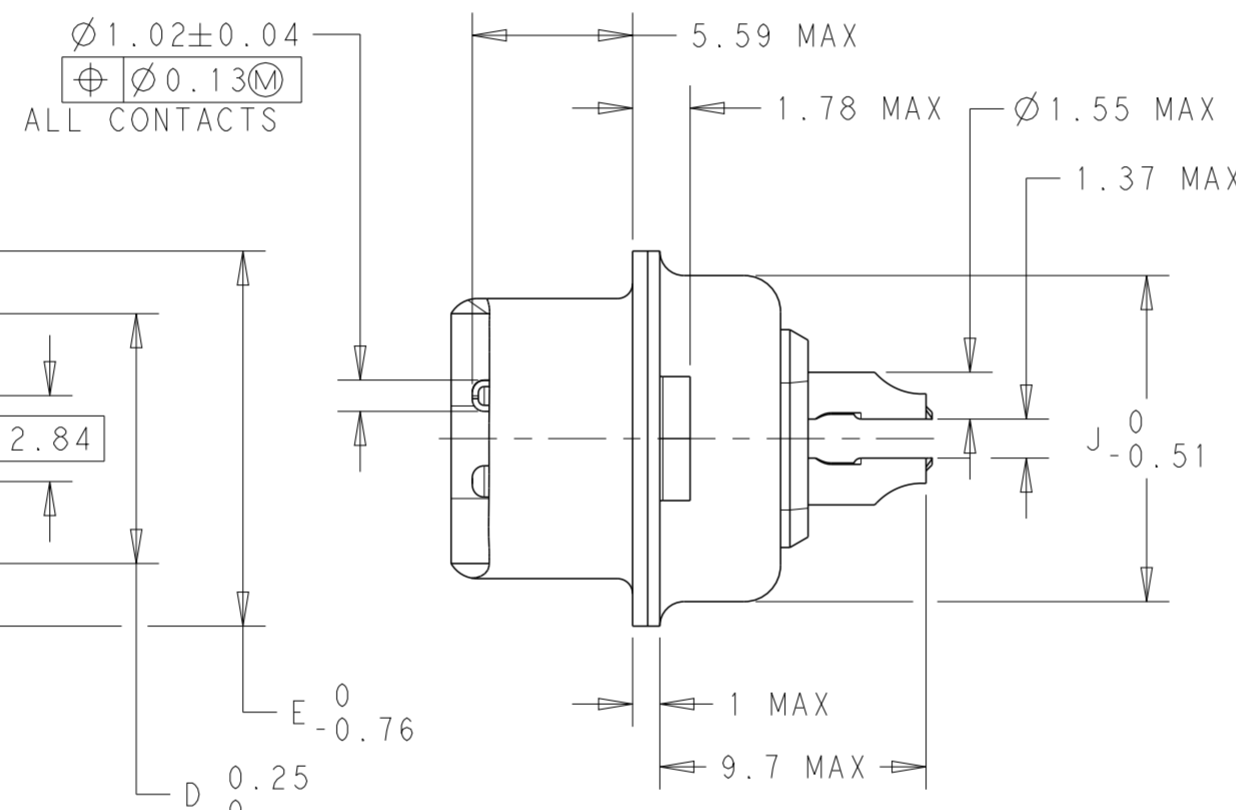
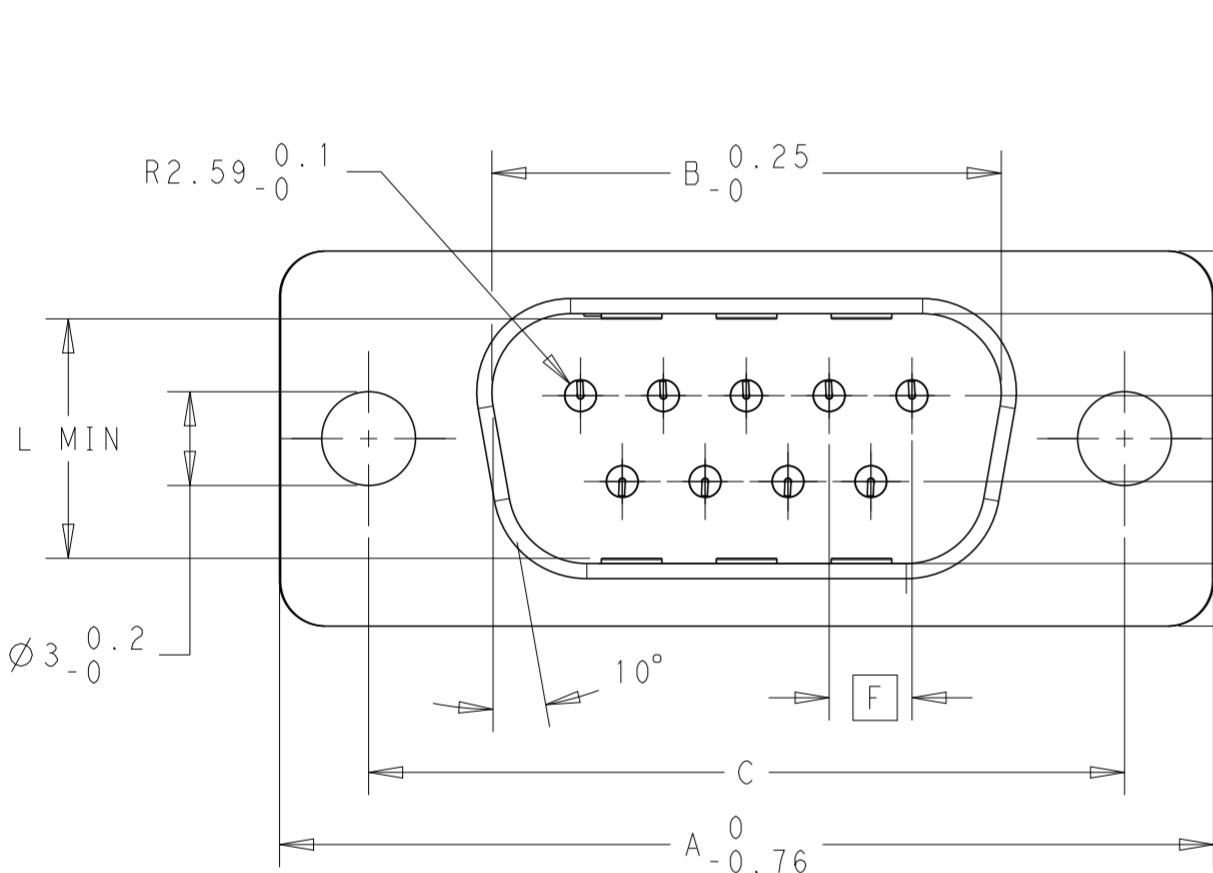
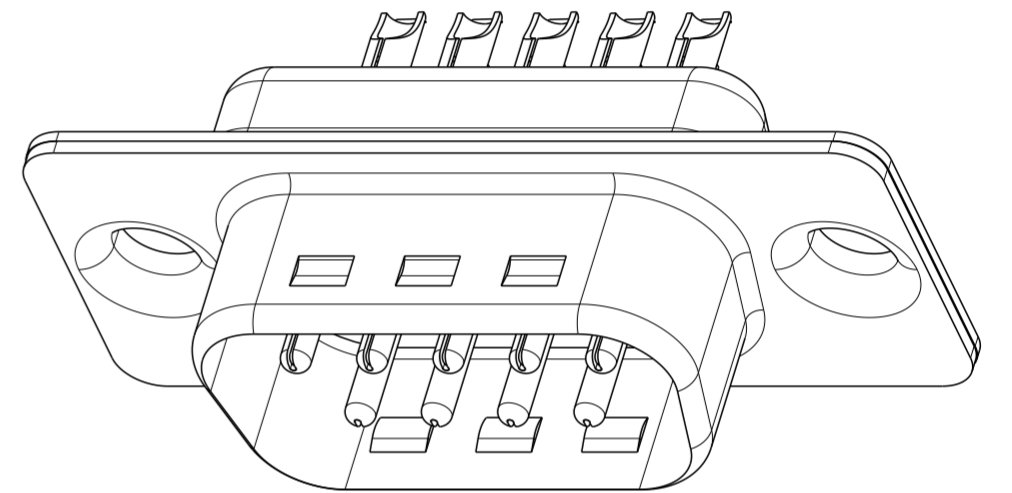
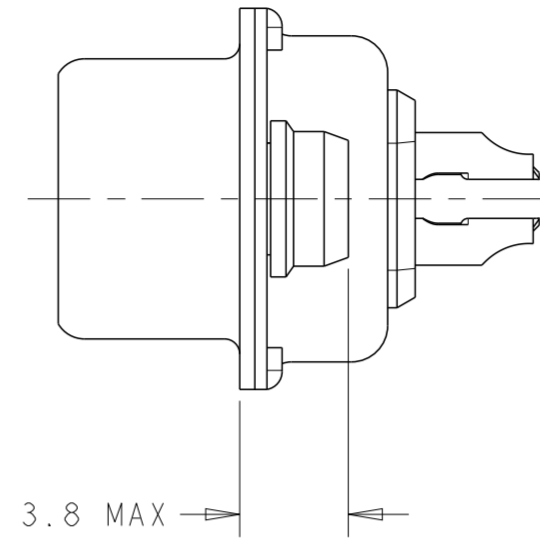

FLANGES WITH HOLES

- 9 POSITION VERSION SHOWN.
 - CONTACTS ARE STAMPED AND FORMED.
 - PACKAGED IN BLISTER PACKS.
 - PLATING DETAILS: ALL MEET PERFORMANCE LEVEL 2 PER DIN 41652 P.2 AND P.4.
 UNDERPLATE: NICKEL OVER ENTIRE CONTACT
 CONTACT MATING SURFACE: GOLD
 SOLDER CUP END: MATTE TIN
 SHELL PLATING: BRIGHT TIN OVER NICKEL
 - 50 CONTACT VERSION HAS 3 ROWS.
 - M3 LOCKING INSERTS COLORED BLACK, 4-40 INSERTS COLORED BLUE.
- 7 ALL PARTS MARKED WITH TE LOGO.

OBSOLETE	3.0 DIAMETER HOLE	67.31	52.68	61.10 +0.14/-0.11	10.95	15.75	2.76	5.99	55.58	13.82	10.57	10.45	41.80	11	50	V42254-A1115-C250	1-1393740-0
	3.0 DIAMETER HOLE	69.70	55.30	63.50±0.13	8.23	12.93	2.76	5.99	57.96	10.97	10.57	7.65	41.80	11	37	V42254-A1115-C237	5-1393483-0
	3.0 DIAMETER HOLE	53.42	38.84	47.04±0.13	8.23	12.93	2.76	5.99	41.53	10.97	10.57	7.65	26.60	7	25	V42254-A1115-C225	4-1393483-9
	3.0 DIAMETER HOLE	39.52	25.12	33.30 +0.15/-0.1	8.23	12.93	2.74	6.12	27.26	10.97	10.46	7.69	15.20	4	15	V42254-A1115-C215	4-1393483-8
OBSOLETE	3.0 DIAMETER HOLE	31.19	16.79	25.00 +0.12/-0.13	8.23	12.93	2.74	6.12	19.53	10.97	10.46	7.72	7.60	2	9	V42254-A1115-C209	4-1393483-7
	M3 SELF-LOCKING NUTS	31.19	16.79	25.00 +0.12/-0.13	8.23	12.93	2.74	6.12	19.53	10.97	10.46	7.72	7.60	2	9	V42254-A1114-C209	2-1393483-9
	4-40 SELF-LOCKING NUTS	31.19	16.79	25.00 +0.12/-0.13	8.23	12.93	2.74	6.12	19.53	10.97	10.46	7.72	7.60	2	9	V42254-A1112-C209	2-1393483-3
	4-40 SELF-LOCKING NUTS	39.52	25.12	33.30 +0.15/-0.1	8.23	12.93	2.74	6.12	27.26	10.97	10.46	7.69	15.20	4	15	V42254-A1112-C215	1-1392010-6
	FLANGE OPTION	A	B	C	D	E	F	G	H	J	K	L	M	N	NO OF POSITIONS	SIEMENS PART NUMBER	TE CONNECTIVITY PART NUMBER

THIS DRAWING IS A CONTROLLED DOCUMENT. DIMENSIONING AND TOLERANCING PER ASME Y14.5M-2009

DWN: RAGHAVENDRA 13MAR2012
 CHK: CARL ROHDE 13MAR2012
 APVD: CARL ROHDE 13MAR2012

DIMENSIONS: mm

TOLERANCES UNLESS OTHERWISE SPECIFIED:
 0 PLC ±
 1 PLC ±
 2 PLC ±
 3 PLC ±
 4 PLC ±
 ANGLES ±1°
 FINISH

MATERIAL: -

APVD: CARL ROHDE 13MAR2012

PRODUCT SPEC: -
 APPLICATION SPEC: -
 WEIGHT: -

CUSTOMER DRAWING

SCALE: 4:1

SHEET 1 OF 1

REV D

STE TE Connectivity

D-SUB SOLDERING LUGS, MALE CONNECTOR WITH GROUNDING FINGERS

SIZE: A2
 CAGE CODE: 00779
 DRAWING NO: C-2-1393483-3