

600mA, Ultra-Low Dropout, CMOS Regulator

General Description

The RT9187C is a high-performance, 600mA LDO regulator, offering extremely high PSRR and ultra-low dropout. This chip is ideal for portable RF and wireless applications with demanding performance and space requirements.

A noise reduction pin is also available for further reduction of output noise. Regulator ground current increases only slightly in dropout, further prolonging the battery life. The RT9187C also works well with low-ESR ceramic capacitors, reducing the amount of board space necessary for power applications, critical in hand-held wireless devices.

The RT9187C consumes less than 0.1µA in shutdown mode. The other features include ultra-low dropout voltage, high output accuracy, current limiting protection, and high ripple rejection ratio. The RT9187C is available in the SOT-23-5 package.

Ordering Information

RT9187C□□

- Package Type
B : SOT-23-5
- Lead Plating System
G : Green (Halogen Free and Pb Free)

Note :

Richtek products are :

- ▶ RoHS compliant and compatible with the current requirements of IPC/JEDEC J-STD-020.
- ▶ Suitable for use in SnPb or Pb-free soldering processes.

Marking Information

40=DNN	40= : Product Code DNN : Date Code
--------	---------------------------------------

Features

- Ultra-Low-Noise for RF Application
- Ultra-Fast Response in Line/Load Transient
- <0.1µA Standby Current When Shutdown
- Low Dropout : 100mV at 500mA
- Wide Operating Voltage Ranges : 2.5V to 5.5V
- TTL-Logic-Controlled Shutdown Input
- Current Limiting Protection
- Thermal Shutdown Protection
- Only 2.2µF Output Capacitor Required for Stability
- High Power Supply Rejection Ratio
- RoHS Compliant and Halogen Free

Applications

- CDMA/GSM Cellular Handsets
- Battery-Powered Equipment
- Laptop, Palmtops, Notebook Computers
- Hand-Held Instruments
- Mini PCI & PCI-Express Cards
- PCMCIA & New Cards
- Portable Information Appliances

Pin Configurations

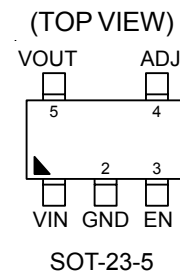

Typical Application Circuit

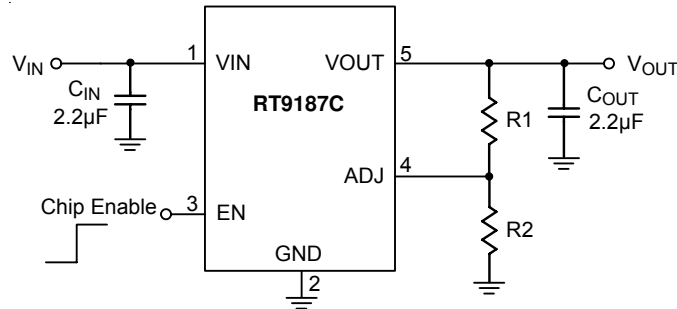

$$V_{OUT} = V_{REF} \times \left(1 + \frac{R1}{R2}\right) \text{ (V)}$$

Note : The value of R2 should be less than 100kΩ to maintain regulation.

Function Pin Description

Pin No.	Pin Name	Pin Function
1	VIN	Voltage Input.
2	GND	Ground.
3	EN	Chip Enable (Active High).
4	ADJ	Output Voltage Feedback.
5	VOUT	Voltage Output.

Function Block Diagram

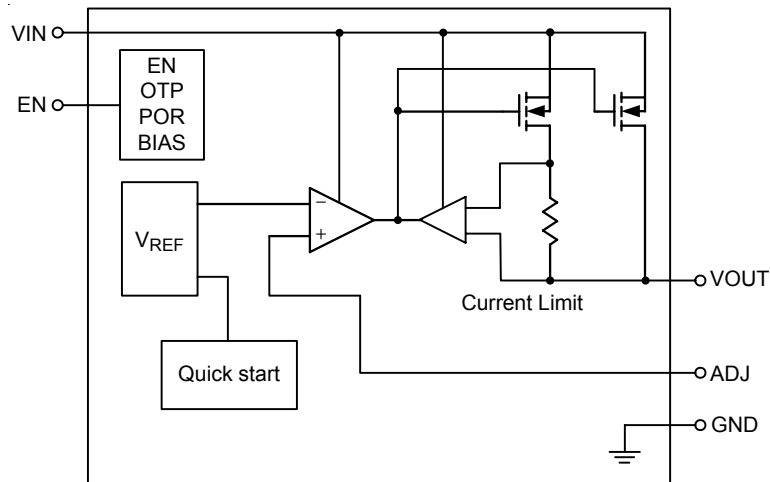

Absolute Maximum Ratings (Note 1)

- Supply Input Voltage ----- 6V
- EN Input Voltage ----- 6V
- Power Dissipation, P_D @ T_A = 25°C
SOT-23-5 ----- 0.400W
- Package Thermal Resistance (Note 2)
SOT-23-5, θ_{JA} ----- 250°C/W
- Lead Temperature (Soldering, 10 sec.) ----- 260°C
- Junction Temperature ----- 150°C
- Storage Temperature Range ----- -65°C to 150°C
- ESD Susceptibility (Note 3)
HBM (Human Body Model) ----- 2kV

Recommended Operating Conditions (Note 4)

- Supply Input Voltage ----- 2.5V to 5.5V
- EN Input Voltage ----- 0V to 5.5V
- Junction Temperature Range ----- -40°C to 125°C
- Ambient Temperature Range ----- -40°C to 85°C

Electrical Characteristics

(V_{IN} = V_{OUT} + 1V, V_{EN} = V_{IN}, C_{IN} = C_{OUT} = 2.2μF (Ceramic), T_A = 25°C, unless otherwise specified)

Parameter		Symbol	Test Conditions	Min	Typ	Max	Unit
Reference Voltage Tolerance		V _{REF}		0.784	0.8	0.816	V
ADJ Pin Current		I _{ADJ}	V _{ADJ} = V _{REF}	--	10	100	nA
Quiescent Current (Note 5)		I _Q	V _{EN} ≥ V _{IH} , I _{OUT} = 0mA	--	300	400	μA
Standby Current (Note 6)		I _{STBY}	V _{EN} ≤ V _{IL} , V _{IN} = 3.3V	--	0.1	1	μA
Current Limit		I _{LIM}	R _{LOAD} = 0.5Ω, V _{IN} = 3.3V	0.9	--	--	A
Dropout Voltage (Note 7)		V _{DROP}	I _{OUT} = 0.3A, V _{OUT} = 5V	--	60	100	mV
			I _{OUT} = 0.5A, V _{OUT} = 5V	--	100	200	
Load Regulation (Note 8)		ΔV _{LOAD}	V _{IN} = (V _{OUT} + 0.5V) 10mA < I _{OUT} < 0.5A	--	0.4	--	%/A
EN Threshold Voltage	Logic-High	V _{IH}	V _{IN} = 3.3V	1.8	--	--	V
	Logic-Low	V _{IL}	V _{IN} = 3.3V	--	--	0.6	
EN Current		I _{EN}	V _{IN} = 3.3V, Enable	--	0.1	1	μA
Power Supply Rejection Rate	f = 100Hz	PSRR	I _{OUT} = 300mA	--	-60	--	dB
	f = 10kHz			--	-50	--	
Line Regulation		ΔV _{LINE}	V _{IN} = (V _{OUT} + 0.5) to 5.5V, I _{OUT} = 1mA	--	--	0.3	%
Start-Up Time		t _{Start_Up}	R _{LOAD} = 3Ω	--	150	--	μs
Thermal Shutdown Temperature		T _{SD}		--	170	--	°C
Thermal Shutdown Hysteresis		ΔT _{SD}		--	30	--	

- Note 1.** Stresses beyond those listed “Absolute Maximum Ratings” may cause permanent damage to the device. These are stress ratings only, and functional operation of the device at these or any other conditions beyond those indicated in the operational sections of the specifications is not implied. Exposure to absolute maximum rating conditions may affect device reliability.
- Note 2.** θ_{JA} is measured at $T_A = 25^\circ\text{C}$ on a low effective thermal conductivity single-layer test board per JEDEC 51-3.
- Note 3.** Devices are ESD sensitive. Handling precaution is recommended.
- Note 4.** The device is not guaranteed to function outside its operating conditions.
- Note 5.** Quiescent, or ground current, is the difference between input and output currents. It is defined by $I_Q = I_{IN} - I_{OUT}$ under no load condition ($I_{OUT} = 0\text{mA}$). The total current drawn from the supply is the sum of the load current plus the ground pin current.
- Note 6.** Standby current is the input current drawn by a regulator when the output voltage is disabled by a shutdown signal ($V_{EN} < 0.6\text{V}$).
- Note 7.** The dropout voltage is defined as $V_{IN} - V_{OUT}$, which is measured when V_{OUT} is $V_{OUT(NORMAL)} - 100\text{mV}$.
- Note 8.** Regulation is measured at constant junction temperature by using a 2ms current pulse. Devices are tested for load regulation in the load range from 10mA to 0.5A.

Typical Operating Characteristics

($C_{OUT} = 2.2\mu F/5R$, unless otherwise specified)

Dropout Voltage vs. Load Current

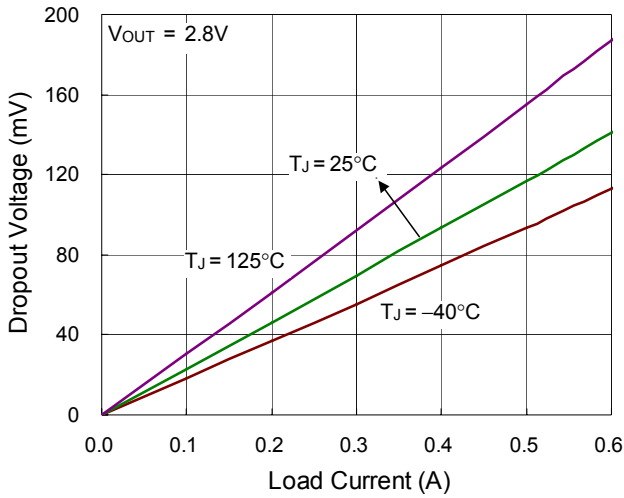

Current Limit

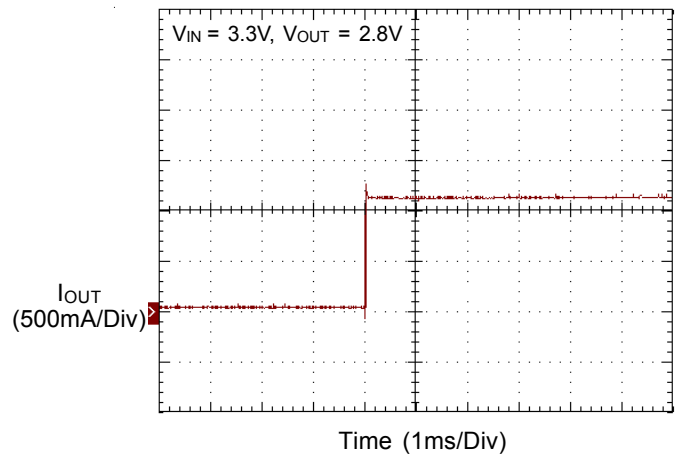

Reference Voltage vs. Temperature

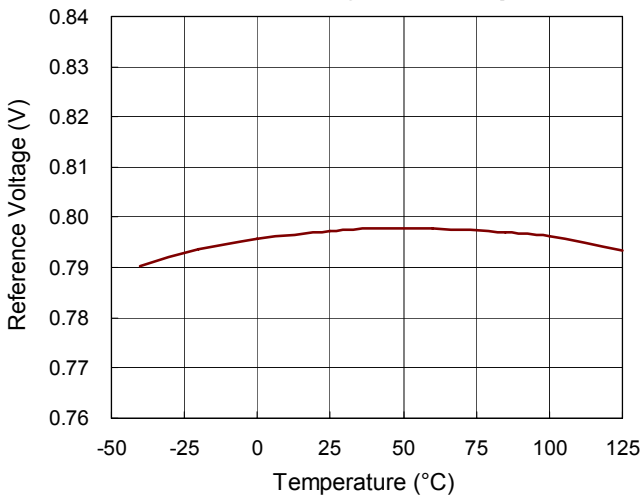

Quiescent Current vs. Temperature

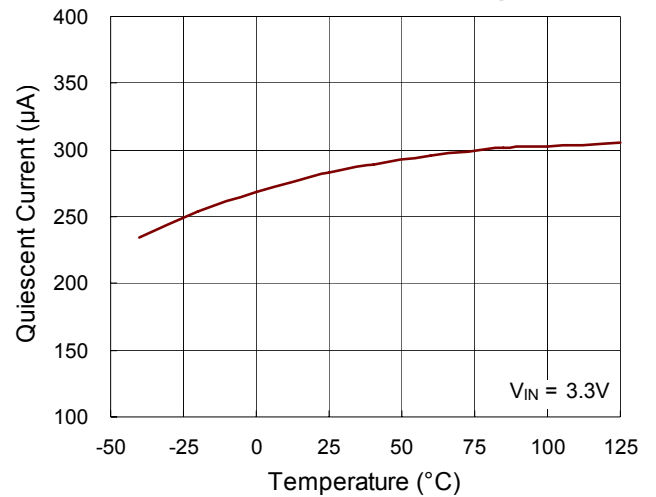

EN Threshold Voltage vs. Temperature

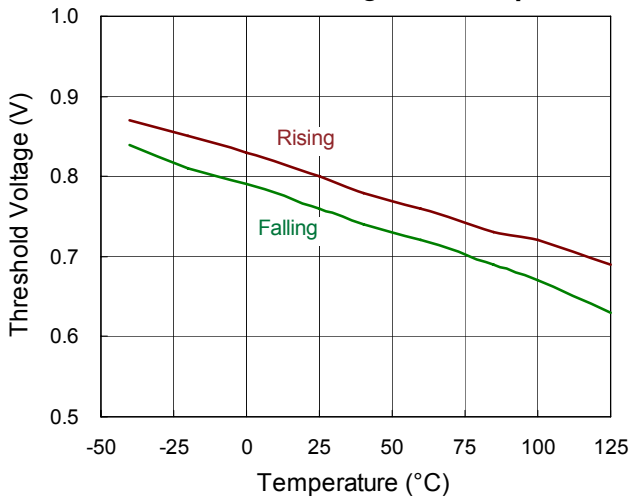

EN Pin Shutdown Response

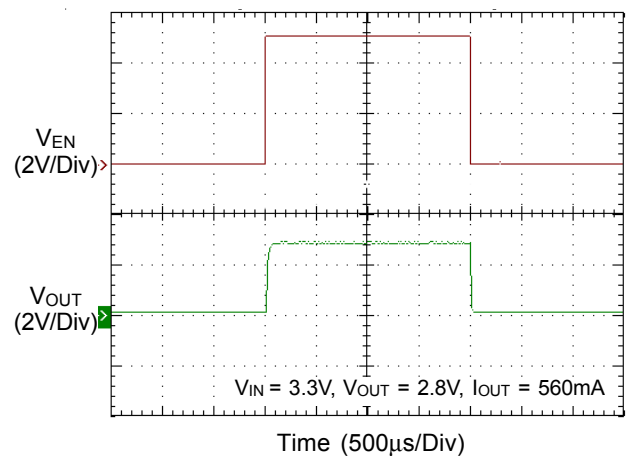

Start Up

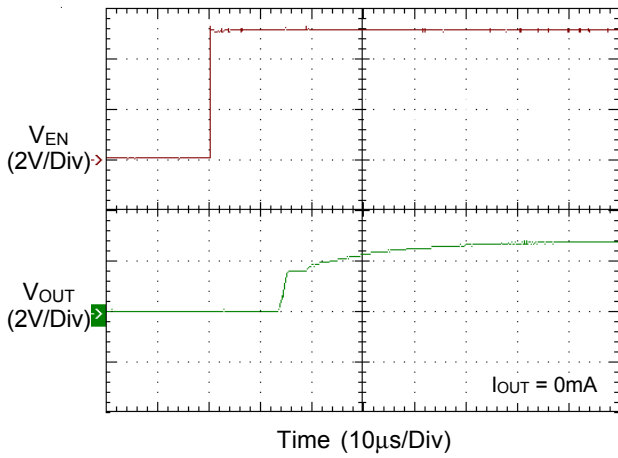

Line Transient Response

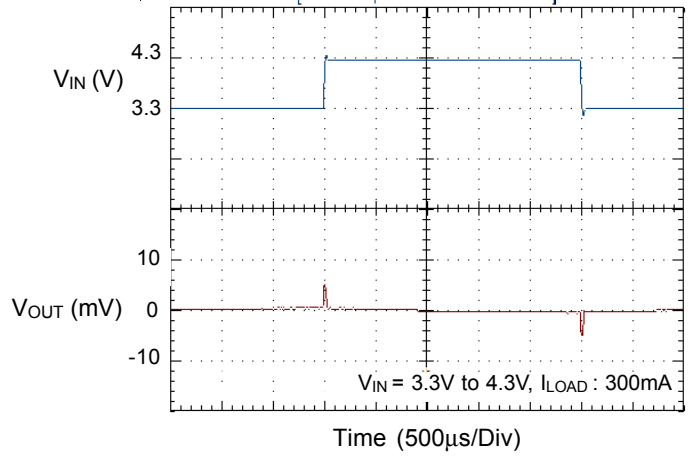

Load Transient Response

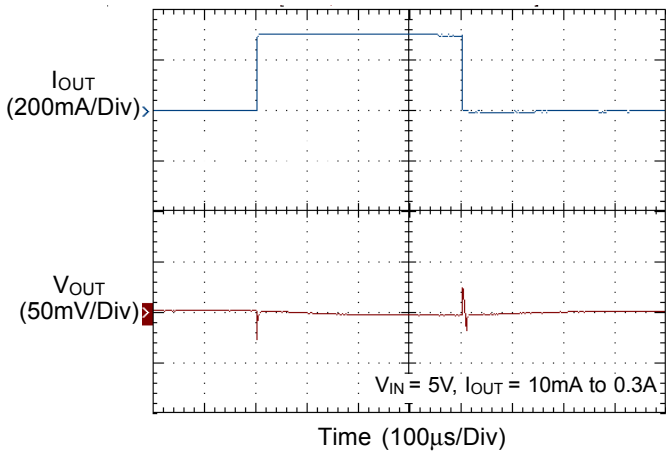

PSRR

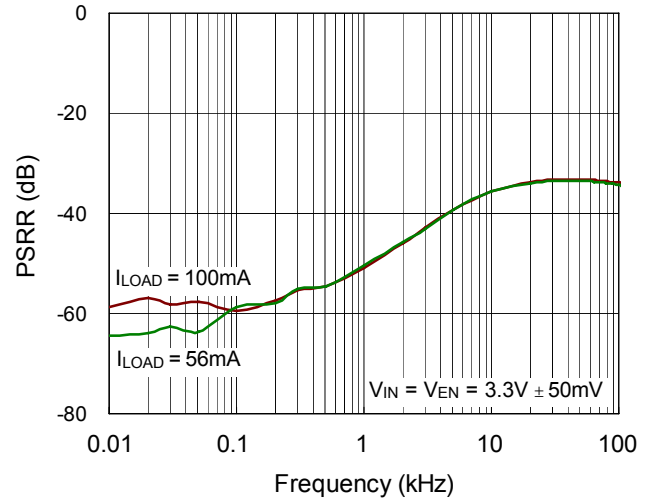

Region of Stable C_{OUT} ESR vs. Load Current

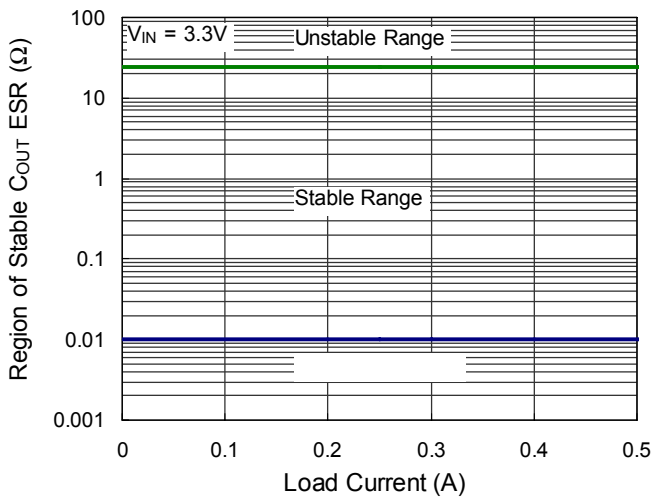

Applications Information

Output Voltage Setting

The voltage divider resistors can have values up to 100kΩ because of the very high impedance and low bias current of the sense comparator. The output voltage is set according to the following equation :

$$V_{OUT} = V_{REF} \times \left(1 + \frac{R1}{R2}\right)$$

where V_{REF} is the reference voltage with a typical value of 0.8V. When the ADJ short to V_{OUT} , there must be a resistor (<100kΩ) from ADJ to GND.

Chip Enable Operation

The RT9187C goes into sleep mode when the EN pin is in a logic low condition. In this condition, the pass transistor, error amplifier, and band gap are all turned off, reducing the supply current to 1μA (max.). The EN pin can be directly tied to V_{IN} to keep the part on.

C_{IN} and C_{OUT} Selection

Like any low dropout regulator, the external capacitors of the RT9187C must be carefully selected for regulator stability and performance. Using a capacitor of at least 2.2μF is suitable. The input capacitor must be located at a distance of not more than 0.5 inch from the input pin of the IC. Any good quality ceramic capacitor can be used. However, a capacitor with larger value and lower ESR (Equivalent Series Resistance) is recommended since it will provide better PSRR and line transient response. The RT9187C is designed specifically to work with low ESR ceramic output capacitor for space saving and performance consideration. Using a ceramic capacitor with value at least 2.2μF and ESR larger than 10mΩ on the RT9187C output ensures stability. Nevertheless, the RT9187C can still work well with other types of output capacitors due to its wide range of stable ESR. “Typical Operating Characteristics” shows the allowable ESR range as a function of load current for various output capacitance. Output capacitors with larger capacitance can reduce noise and improve load transient response, stability, and PSRR. The output capacitor should be located at a distance of not more than 0.5 inch from the output pin of the RT9187C.

Thermal Considerations

For continuous operation, do not exceed absolute maximum junction temperature. The maximum power dissipation depends on the thermal resistance of the IC package, PCB layout, rate of surrounding airflow, and difference between junction and ambient temperature. The maximum power dissipation can be calculated by the following formula :

$$P_{D(MAX)} = (T_{J(MAX)} - T_A) / \theta_{JA}$$

where $T_{J(MAX)}$ is the maximum junction temperature, T_A is the ambient temperature, and θ_{JA} is the junction to ambient thermal resistance.

For recommended operating condition specifications, the maximum junction temperature is 125°C. The junction to ambient thermal resistance, θ_{JA} , is layout dependent. For SOT-23-5 packages, the thermal resistance, θ_{JA} , is 250°C/W on a standard JEDEC 51-3 single-layer thermal test board. The maximum power dissipation at $T_A = 25^\circ\text{C}$ can be calculated by the following formula :

$$P_{D(MAX)} = (125^\circ\text{C} - 25^\circ\text{C}) / (250^\circ\text{C/W}) = 0.400\text{W for SOT-23-5 package}$$

The maximum power dissipation depends on the operating ambient temperature for fixed $T_{J(MAX)}$ and thermal resistance, θ_{JA} . The derating curve in Figure 1 allows the designer to see the effect of rising ambient temperature on the maximum power dissipation.

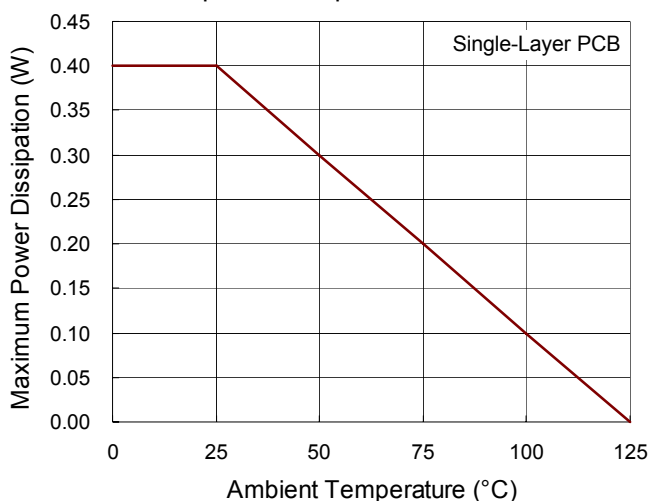
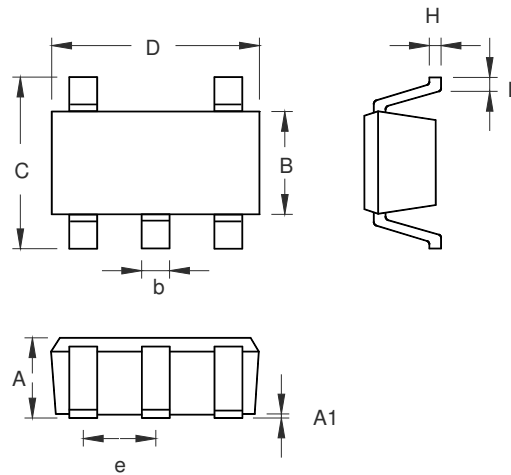

Figure 1. Derating Curve of Maximum Power Dissipation

Outline Dimension



Symbol	Dimensions In Millimeters		Dimensions In Inches	
	Min	Max	Min	Max
A	0.889	1.295	0.035	0.051
A1	0.000	0.152	0.000	0.006
B	1.397	1.803	0.055	0.071
b	0.356	0.559	0.014	0.022
C	2.591	2.997	0.102	0.118
D	2.692	3.099	0.106	0.122
e	0.838	1.041	0.033	0.041
H	0.080	0.254	0.003	0.010
L	0.300	0.610	0.012	0.024

SOT-23-5 Surface Mount Package

Richtek Technology Corporation

5F, No. 20, Taiyuen Street, Chupei City
 Hsinchu, Taiwan, R.O.C.
 Tel: (8863)5526789

Richtek products are sold by description only. Richtek reserves the right to change the circuitry and/or specifications without notice at any time. Customers should obtain the latest relevant information and data sheets before placing orders and should verify that such information is current and complete. Richtek cannot assume responsibility for use of any circuitry other than circuitry entirely embodied in a Richtek product. Information furnished by Richtek is believed to be accurate and reliable. However, no responsibility is assumed by Richtek or its subsidiaries for its use; nor for any infringements of patents or other rights of third parties which may result from its use. No license is granted by implication or otherwise under any patent or patent rights of Richtek or its subsidiaries.