

**SQUARE FLANGE JACK RECEPTACLE**

**R125.612.120**

**TAB CONTACT**

Series : SMA

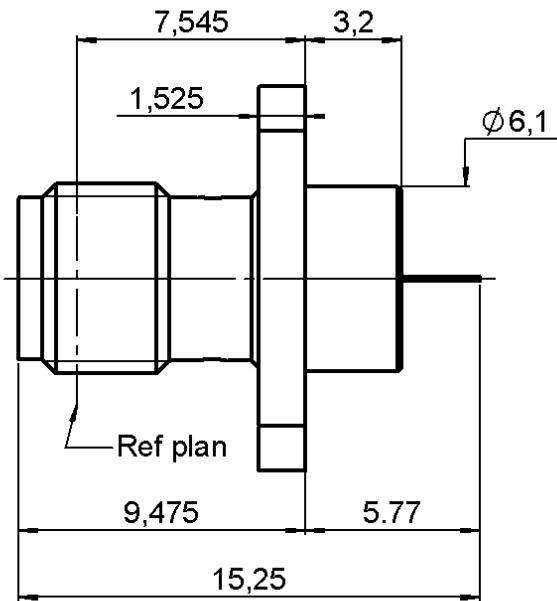
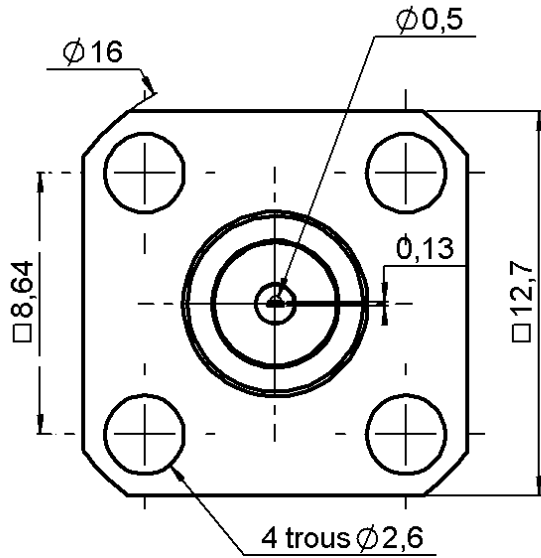

**PANEL CUT OUT**

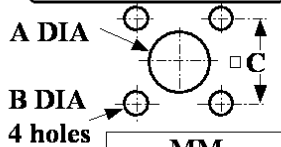

	MM	
	Maxi	mini
A	6.4	6.3
B	2.8	2.7
C	8.69	8.59

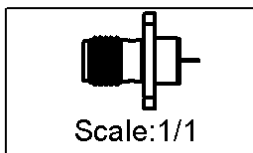
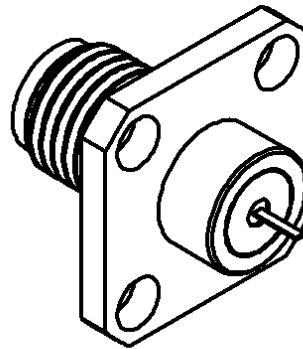

All dimensions are in mm.

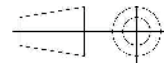

COMPONENTS	MATERIALS	PLATINGS (µm)
BODY	STAINLESS STEEL	GOLD 0.5 OVER NICKEL 2
CENTER CONTACT	BERYLLIUM COPPER	GOLD 1.3 OVER NICKEL 2
OUTER CONTACT	-	-
INSULATOR	PTFE	-
GASKET	-	-
OTHERS PARTS	-	-
.	.	.
.	.	.

Issue : 0434 A

In the effort to improve our products, we reserve the right to make changes judged to be necessary.



**SQUARE FLANGE JACK RECEPTACLE**

**R125.612.120**

**TAB CONTACT**

Series : SMA

**PACKAGING**

**SPECIFICATION**

Standard	Unit	Other
<b>100</b>	<b>'W' option</b>	<b>Contact us</b>

**ELECTRICAL CHARACTERISTICS**

**ENVIRONMENTAL**

Impedance		<b>50</b> Ω
Frequency		<b>0-18</b> GHz
VSWR	<b>1.06*</b> +	<b>0.002</b> x F(GHz) Maxi
Insertion loss		<b>0.07</b> √F(GHz) dB Maxi
RF leakage	- (	<b>60</b> - F(GHz)) dB Maxi
Voltage rating		<b>500</b> Veff Maxi
Dielectric withstanding voltage		<b>1000</b> Veff mini
Insulation resistance		<b>5000</b> MΩ mini

Operating temperature	<b>-65/+165</b> ° C
Hermetic seal	<b>NA</b> Atm.cm3/s
Panel leakage	<b>NA</b>

**OTHERS CHARACTERISTICS**

Assembly instruction

Others :

\*COAXIAL TRANSMISSION LINE ONLY

**MECHANICAL CHARACTERISTICS**

Center contact retention		
Axial force – Mating end		<b>27</b> N mini
Axial force – Opposite end		<b>27</b> N mini
Torque		<b>2.8</b> N.cm mini
Recommended torque		
Mating		<b>NA</b> N.cm
Panel nut		<b>NA</b> N.cm
Mating life		<b>500</b> Cycles mini
Weight		<b>3.003</b> g

Issue : 0434 A

In the effort to improve our products, we reserve the right to make changes judged to be necessary.



**RADIALL**®