

- 1. USE WITH PRO-CRIMPER 354940-1.
- 2. MAXIMUM PANEL THICKNESS: 6.10 [.240]
- 3. SEE INSTRUCTION SHEET 408-9051

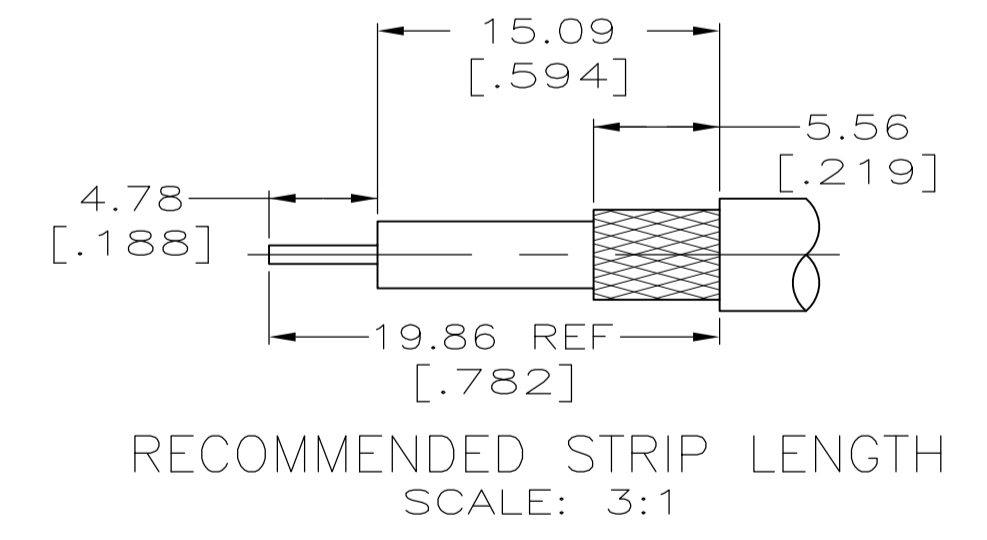
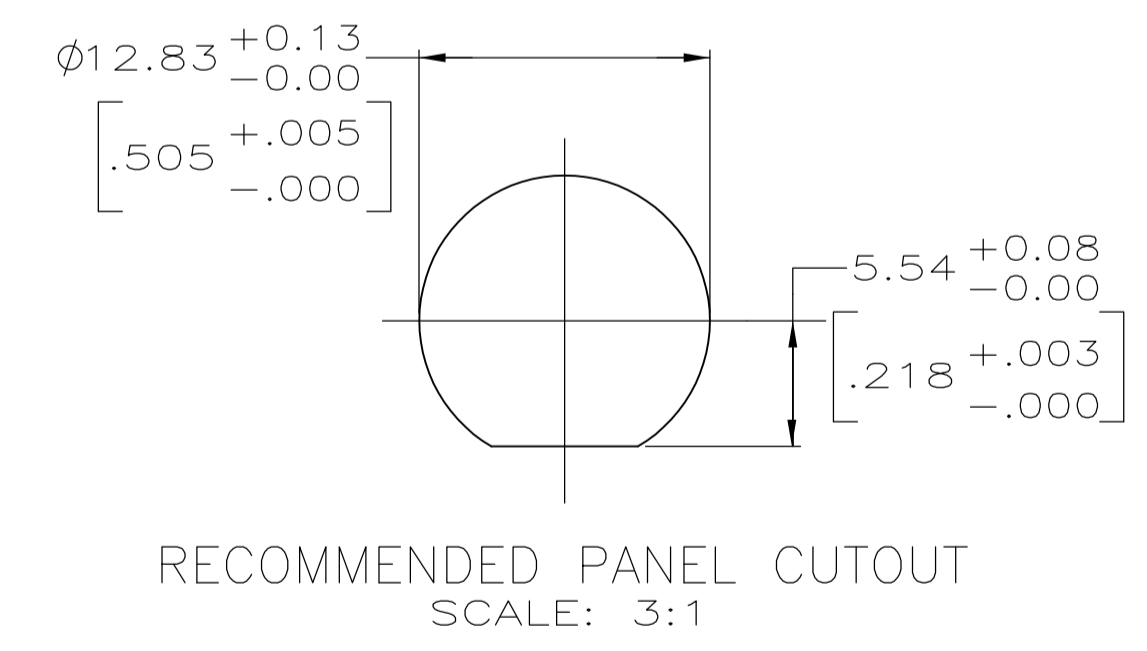
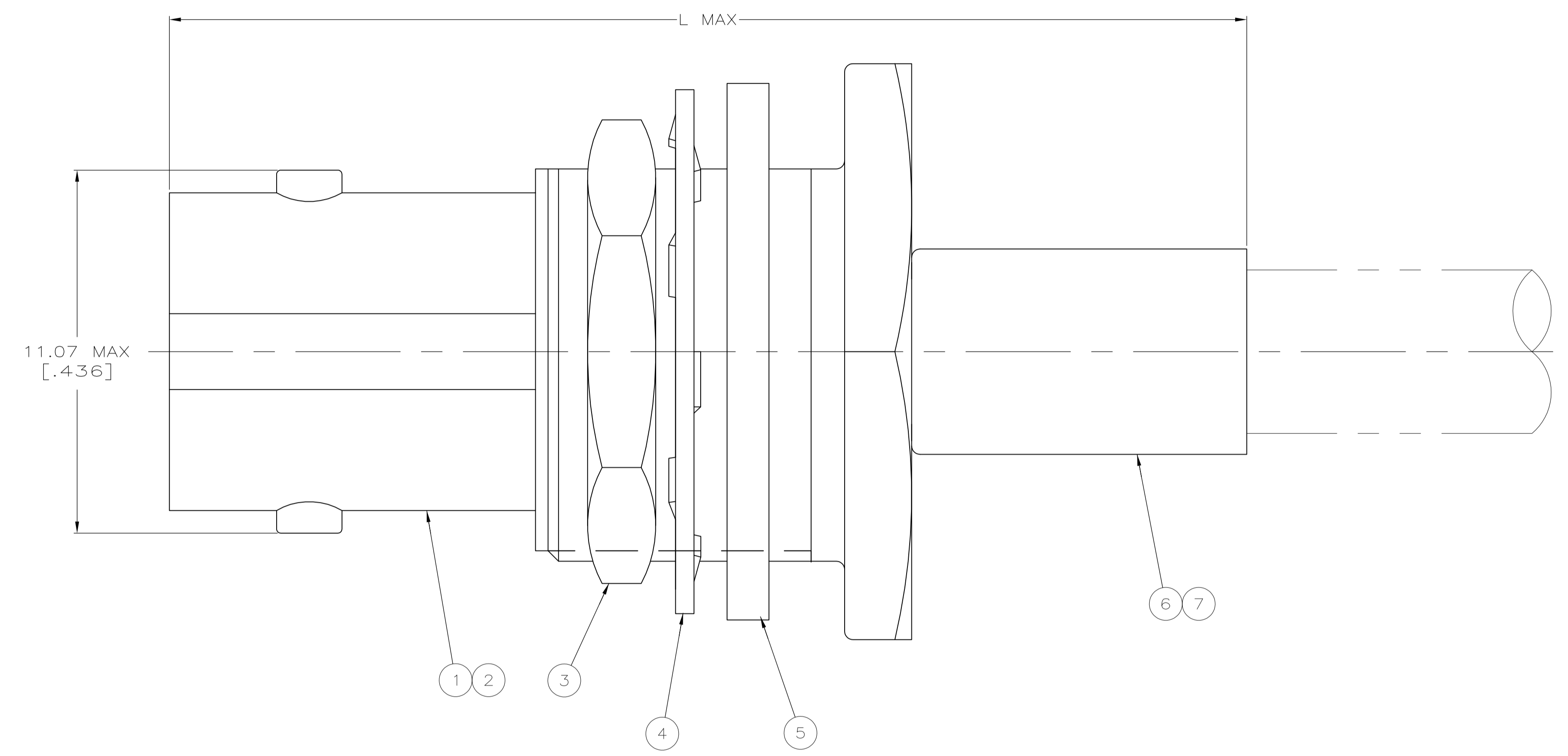

RG-174/U, 188/U, 316/U	34.93 [1.375]	220210-1	220009-5	21427-4	9-328666-0	329633	1-329632-2	1-329631-2	2-221149-0	227461-1	5228980-7
RG-59/U, 59A/U, 59B/U, 62/U, 62A/U, 62B/U	34.93 [1.375]	220189-2	220187-2	-	9-50428-0	329633	1-329632-2	1-329631-2	1-221149-3	227461-3	5228980-6
RG-58/U, 58A/U, 58B/U, 58C/U, 141/U, 141A/U	34.93 [1.375]	220189-1	220187-1	-	9-50427-1	329633	1-329632-2	1-329631-2	221149-6	227461-2	5228980-5
FOR USE WITH CABLE	L	DIE SET	CRIMP TOOLING	BUSHING QTY=1	FERRULE QTY=1	GASKET QTY=1	LOCKWASHER QTY=1	JAM NUT QTY=1	CONTACT QTY=1	JACK ASSEMBLY QTY=1	PART NUMBER

THIS DRAWING IS A CONTROLLED DOCUMENT.

DIMENSIONS: mm [INCHES]	TOLERANCES UNLESS OTHERWISE SPECIFIED:	DIN J. HAVENER 31MAR2005	TE Connectivity JACK, BHD, COMMERCIAL, BNC
	0 PLC ± -	CHK J. HAVENER 31MAR2005	
	1 PLC ± -	APVD J. LIPPERT 31MAR2005	
	2 PLC ± 0.41 [016]	NAME	
	3 PLC ± -	PRODUCT SPEC	108-12047
	4 PLC ± -	APPLICATION SPEC	
	ANGLES ± -	SIZE	A1
MATERIAL	FINISH	WEIGHT	00779 C=5228980
		CUSTOMER DRAWING	SCALE 10:1 SHEET 1 OF 1 REV A1