

# iSYS-4001

detection fields V1.1

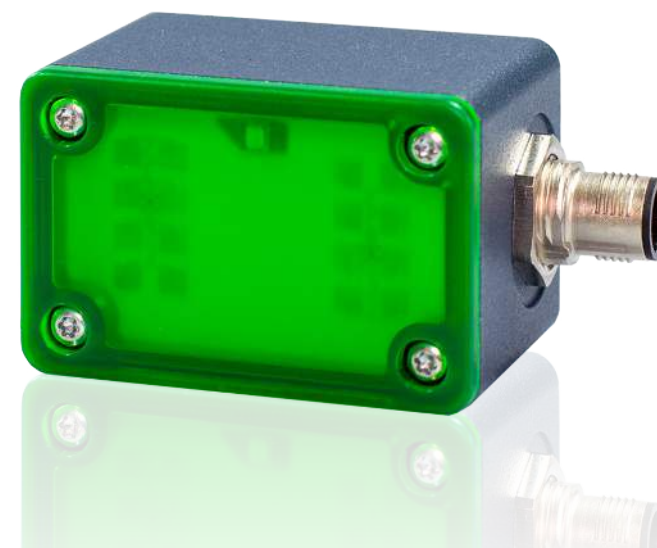
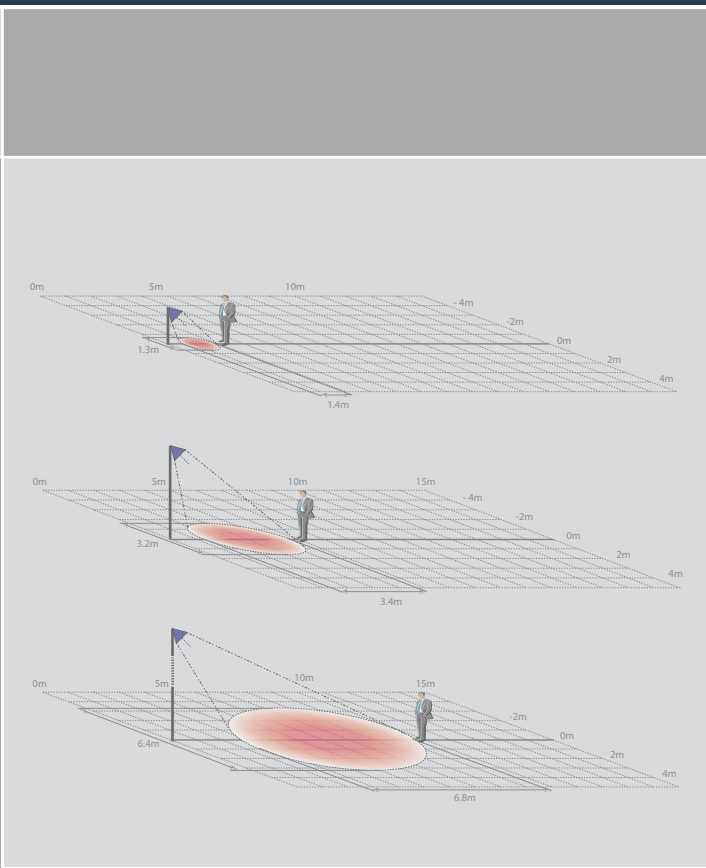

## content

- typical detection pattern for a person 4
- typical detection distance for cars 6
- maximum detection distance for cars 7
- maximum detection distance for a person 7
- more details 8
- contact 9

# iSYS-4001

## detection fields

This document gives you a guidance about the to expected detection fields of the iSYS-4001 in different mounting situations.

## typical detection pattern for a person

To get an impression about the typical detection areas of the iSYS-4001 real measurements were performed. The pictures below shows the typical detection areas for a person. To achieve similar results use config file „Short Range.ipf“ available @ [www.innosent.de](http://www.innosent.de).

### side - view

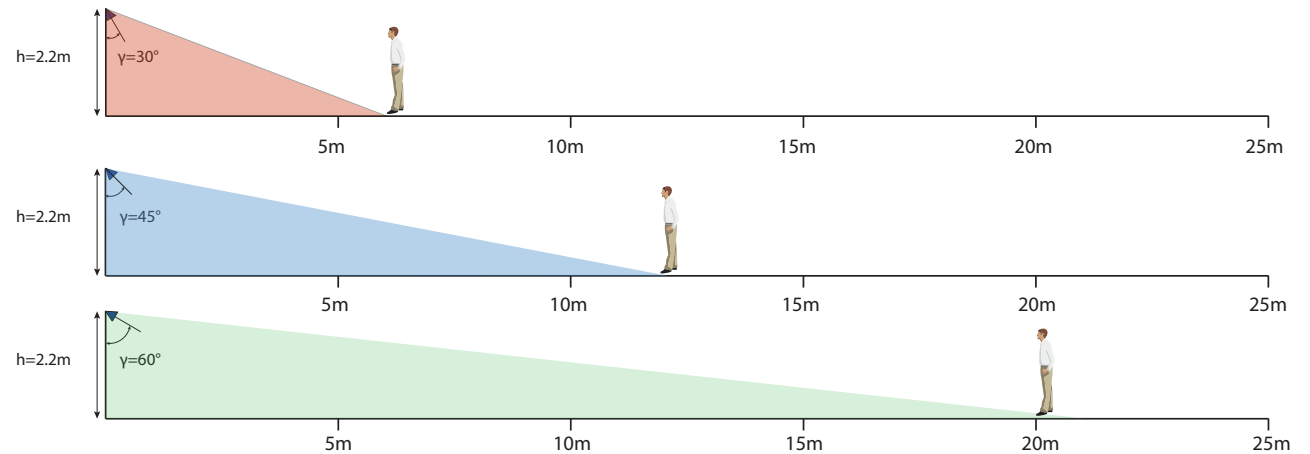
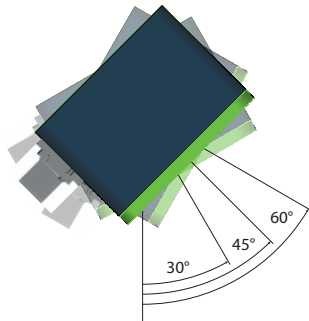

### top - view

The schematic beside shows typical detection areas for the iSYS-4001.

The detection areas are based on real measurements but can differ for objects with different RCS.

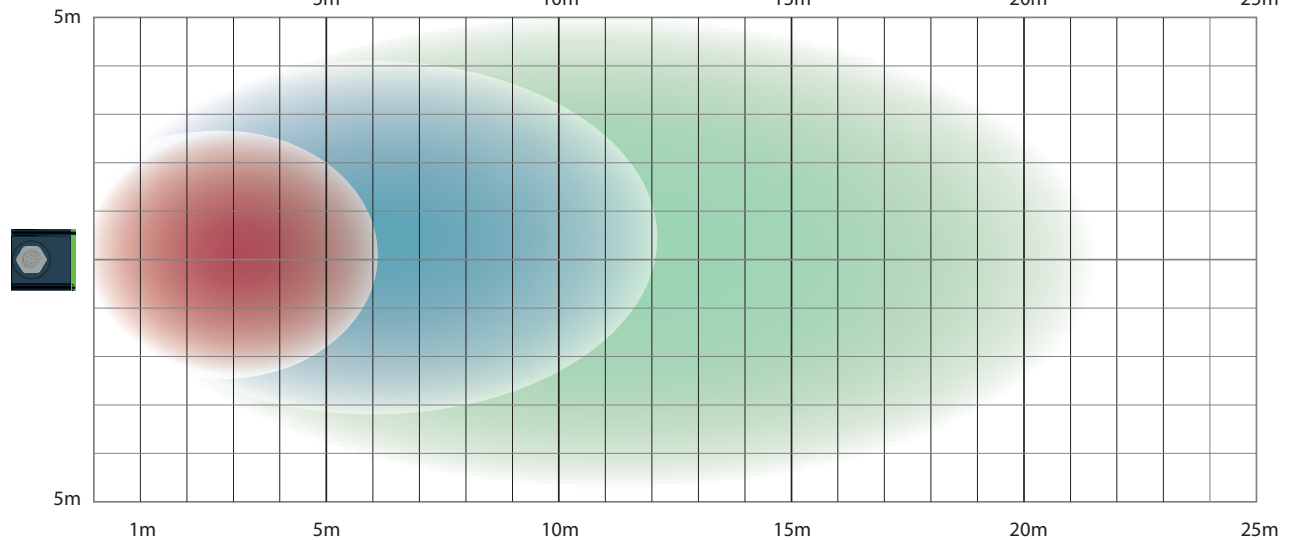

side - view

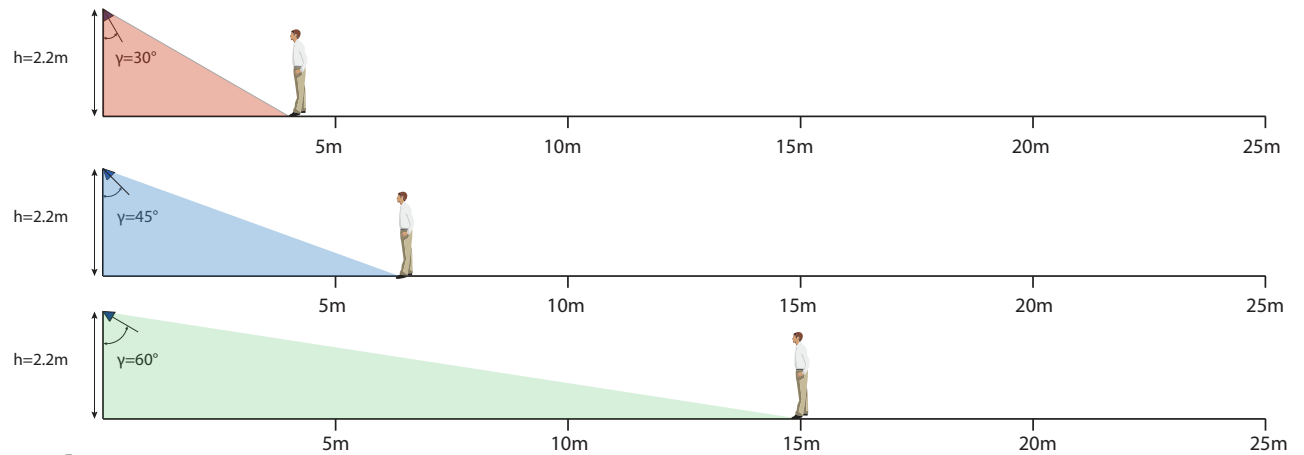
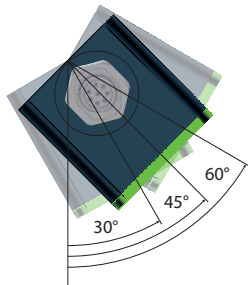

top - view

The schematic beside shows typical detection areas for the iSYS-4001.

The detection areas are based on real measurements but can differ for objects with different RCS.

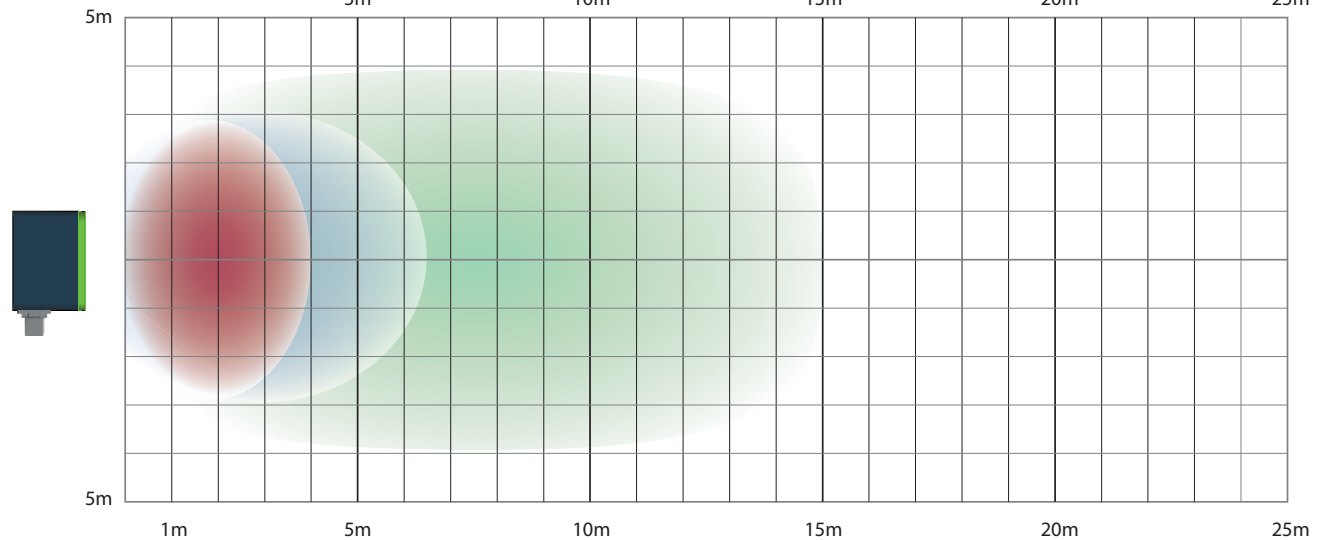

## typical detection pattern for cars

To get an impression about the typical detection range of the iSYS-4001 real measurements were performed. The pictures below shows the typical detection areas for cars for different mounting situations of the sensor. To achieve similar results use config file „Long Range.ipf“ available @ [www.innosent.de](http://www.innosent.de).

### sensor mounting

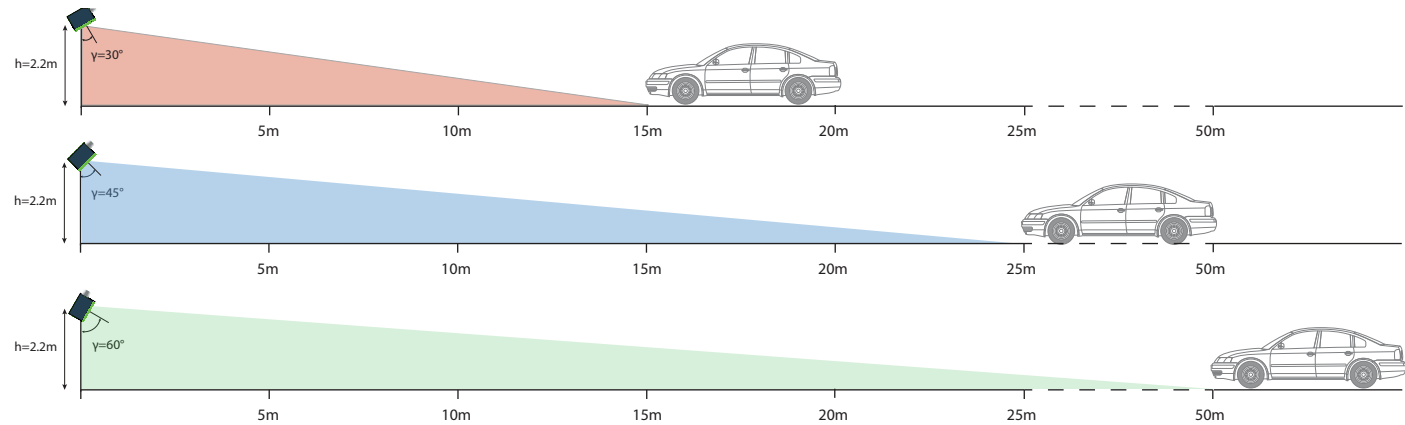
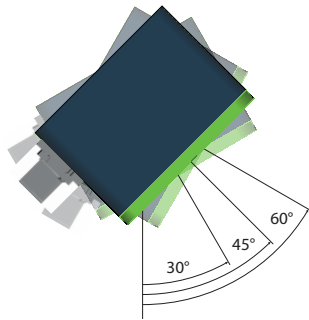

### sensor mounting

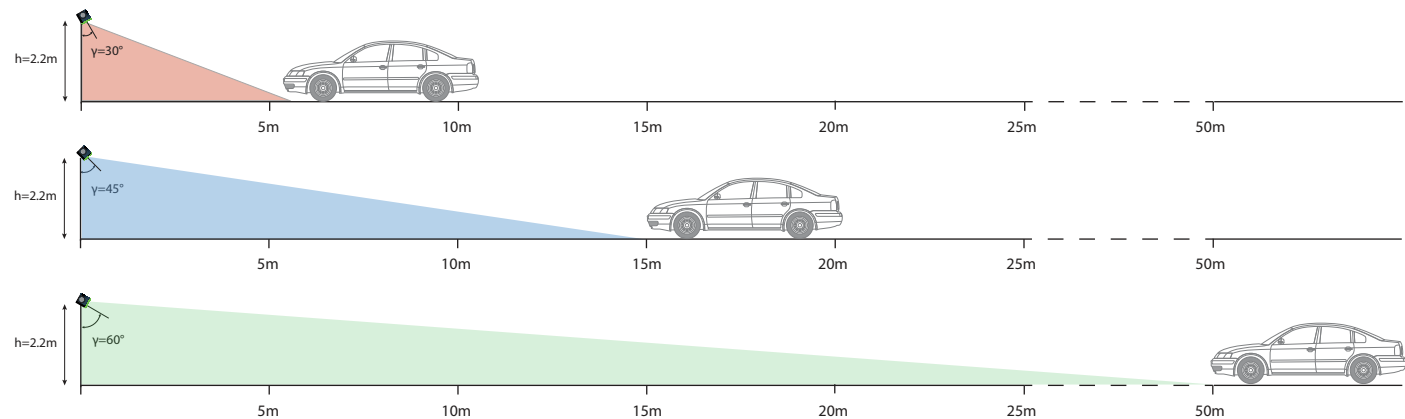
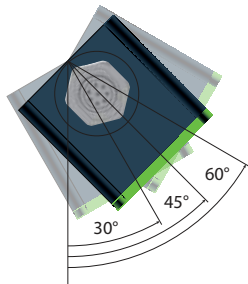

## maximum detection distance for cars and persons

To get an impression about the typical detection range of the iSYS-4001 real measurements were performed. The pictures below shows the typical detection areas for cars for different mounting situations of the sensor. To achieve similar results use config file „Long Range.ipf“ available @ [www.innosent.de](http://www.innosent.de).

### maximum detection distance - cars

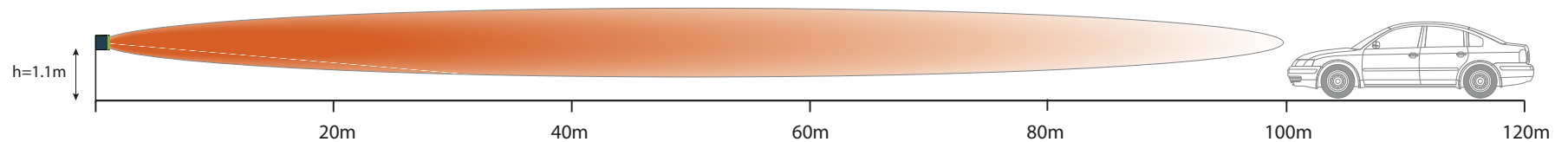

The maximum detection distance is depending on the size of the car, typically a detection distance of 100m with an medium size car can be achieved. For bigger vehicles even larger distances are possible.

### maximum detection distance - persons

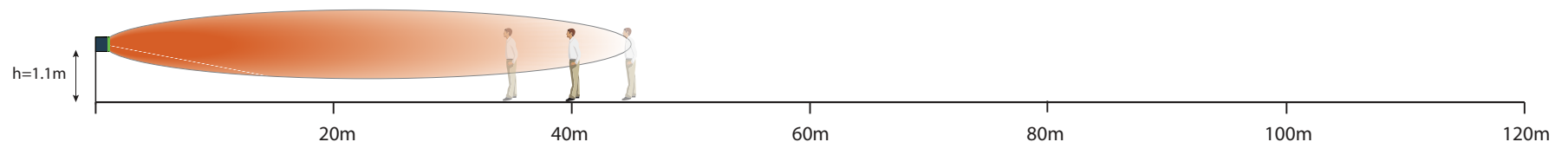

The maximum detection distance is depending on how the person is moving towards the sensor. A minimum of 35m and a maximum of 45m can be taken as standard values.

## more details...

This quick start guide gives you only a short overview over the physical characteristics of radar. If you want to know more we recommend to have a look on our application notes (available @ [www.innosent.de](http://www.innosent.de)) or contact us directly.





## contact information

If you have any questions please contact us!



Corinna Mergenthal

Tel.: +49-9528-9518-84

E-Mail: corinna.mergenthal@innosent.de



Martin Maidhof

Tel.: +49-9528-9518-18

E-Mail: martin.maidhof@innosent.de

---

## part numbers



P/N: iSYS-4001



P/N: iSYS-prog\_adap



P/N: iSYS-pow\_adap



P/N: iSYS-pow\_sup



*Contact Details:*

Tel: +49-9528-9518-0 | E-Mail: [info@innosent.de](mailto:info@innosent.de) | [www.innosent.de](http://www.innosent.de)