

Click [here](#) for production status of specific part numbers.

MAX14838/MAX14839

24V Pin-Configurable Industrial Sensor Output Drivers

General Description

The MAX14838/MAX14839 24V/100mA drivers are optimized for use in industrial sensors. These devices integrate all of the high-voltage (24V) circuitry commonly found in industrial sensors, including a configurable PNP/NPN/push-pull driver and an integrated linear regulator that meets common sensor power requirements.

The MAX14838/MAX14839 are pin-configurable. Logic inputs allow the driver to be configured for high-side (PNP), low-side (NPN), or push-pull operation. An additional input allows the user to select between normally-open and normally-closed logic.

The MAX14838 features an onboard 5V linear regulator, while the MAX14839 features a 3.3V linear regulator.

Each device includes two LED drivers for visual feedback. One LED driver reflects the output logic status and the other is a general-purpose driver that can be used to signal a fault condition.

The DO output, supply (V_{CC}), and ground (GND) pins are reverse polarity-protected and are protected against IEC ESD and surge events.

The MAX14838 and MAX14839 operate from a wide supply range and are available in a 12-pin TDFN-EP package (3mm x 3mm) or a 12-bump wafer-level package (WLP) (2.1mm x 1.6mm) and operate over the -40°C to $+105^{\circ}\text{C}$ temperature range.

Ordering Information appears at end of data sheet.

Typical Application Circuit

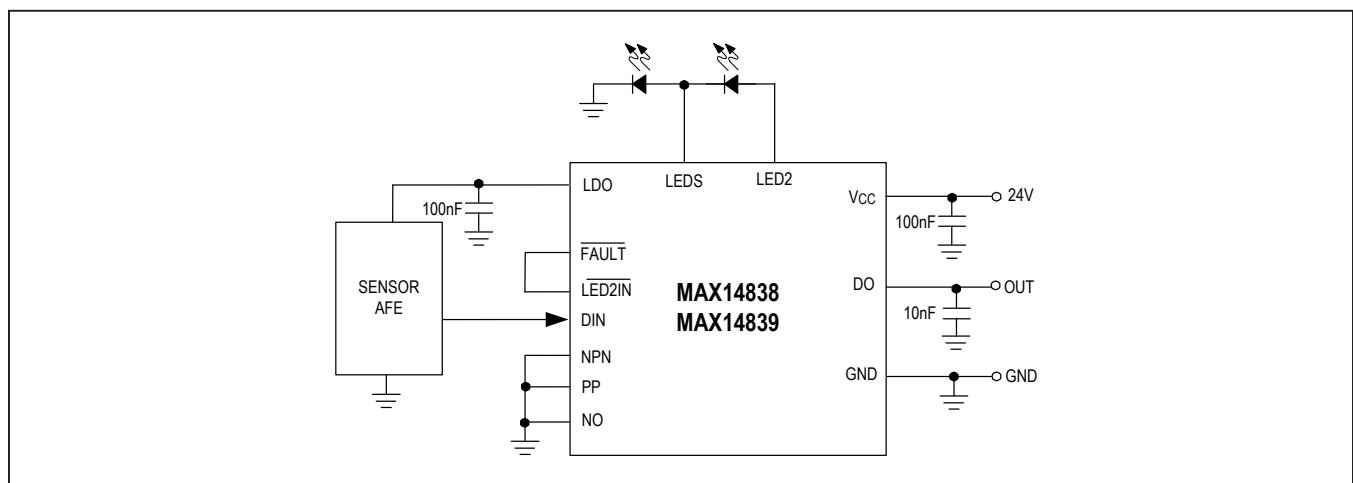

Benefits and Features

- High Configurability Simplifies Design
 - Pin-Selectable High-Side (PNP), Low-Side (NPN), or Push-Pull Driver
 - Pin-Configurable NO/NC Logic
- Integrated Protection Provides Robust Sensor Solutions
 - Reverse-Polarity Protection on DO, V_{CC} , and GND
 - 4.75V to 34V Supply Range (MAX14839)
 - Driver is Short-Circuit Protected
 - FAULT Output for Fault Indication
 - V_{CC} Hot Plug Protection
 - Thermal Shutdown Protection
 - $\pm 1\text{kV}/500\Omega$ Surge Protection
 - $\pm 8\text{kV}$ IEC 61000-4-2 Air Gap ESD Protection
 - $\pm 6\text{kV}$ IEC 61000-4-2 Contact ESD Protection
 - -40°C to $+105^{\circ}\text{C}$ Temperature Range
- Fast Turn-Off of Inductive Loads Up to 1.5H
- Saves Space on Board
 - Available in 12-Pin TDFN-EP (3mm x 3mm) or 12-Bump WLP (2.1mm x 1.6mm)
 - Dual Integrated 2mA LED Drivers

Applications

- Industry Binary Sensors
- Proximity Switches
- Capacitive and Inductive Sensors

Absolute Maximum Ratings

(All voltages referenced to GND, unless otherwise specified.)

V _{CC}	-36V to +36V
LDO	-0.3V to +6V
DO	Higher of (V _{CC} - 36V) and -36V Lower of (V _{CC} + 36V) and +36V
DIN, NPN, PP, NO, LDO2IN, FAULT.....	-0.3V to +6V
LEDS, LED2	-0.3V to the higher of (V _{CC} - 0.3V) and +0.3V

Continuous Power Dissipation (T_A = +70°C)

Multiple-Layer Board (derate at 24.4mW/°C above +70°C)	1950mW
Operating Temperature Range	-40°C to +105°C
Junction Temperature	+150°C
Storage Temperature Range	-65°C to +150°C
Solder Temperature (Reflow)	+260°C

Stresses beyond those listed under "Absolute Maximum Ratings" may cause permanent damage to the device. These are stress ratings only, and functional operation of the device at these or any other conditions beyond those indicated in the operational sections of the specifications is not implied. Exposure to absolute maximum rating conditions for extended periods may affect device reliability.

Package Information

PACKAGE TYPE: 12 TDFN	
Package Code	TD1233+1
Outline Number	21-0664
Land Pattern Number	90-0397
THERMAL RESISTANCE, FOUR-LAYER BOARD	
Junction to Ambient (θ _{JA})	41°C/W
Junction to Case (θ _{JC})	8.5°C/W

PACKAGE TYPE: 12 WLP	
Package Code	W121C2+1
Outline Number	21-0009
Land Pattern Number	Refer to Application Note 1891
THERMAL RESISTANCE, FOUR-LAYER BOARD	
Junction to Ambient (θ _{JA})	62°C/W

For the latest package outline information and land patterns (footprints), go to www.maximintegrated.com/packages. Note that a "+", "#", or "-" in the package code indicates RoHS status only. Package drawings may show a different suffix character, but the drawing pertains to the package regardless of RoHS status.

Package thermal resistances were obtained using the method described in JEDEC specification JESD51-7, using a four-layer board. For detailed information on package thermal considerations, refer to www.maximintegrated.com/thermal-tutorial.

Electrical Characteristics

($V_{CC} = 4.75V$ to $34V$ (MAX14839), $V_{CC} = 7V$ to $34V$ (MAX14838), unless otherwise noted. $V_{GND} = 0V$. All logic inputs are V_{LDO} or GND . $T_A = T_{MIN}$ to T_{MAX} . Typical values are at $V_{CC} = 24V$, $T_A = +25^\circ C$) (Notes 1, 2)

PARAMETER	SYMBOL	CONDITIONS	MIN	TYP	MAX	UNITS	
POWER SUPPLY							
Supply Voltage	V_{CC}	MAX14839	4.75		34	V	
		MAX14838	7		34		
Supply Current	I_{CC}	$V_{CC} = 24V$, no external load on LDO, DO is open-drain or push-pull mode, no load on DO, LED1, and LED2 off			1.2	mA	
Power-On Reset (POR) Threshold	V_{TH}	V_{CC} rising to DO active	MAX14839	4.1		4.7	V
			MAX14838	6.0		7.0	
POR Threshold Hysteresis	V_{HTH}			0.5		V	
DRIVER (DO)							
Output Voltage High	V_{OH}	High-side on, $I_{DO} = -100mA$,	$V_{CC} - 1.7$			V	
Output Voltage Low	V_{OL}	Low-side on, $I_{DO} = 100mA$,			1.7	V	
Current Protection Threshold	$ I_{OCL} $	(Note 3)	120	145	170	mA	
Current Limit	$ I_{CL} $	(Note 3)		350		mA	
DO Weak Pulldown Current in PNP Mode	I_{LDO_HS}	PNP configuration, high-side off, $V_{DO} = V_{CC} - 1V$, $V_{CC} = 34V$	10	20	35	μA	
DO Weak Pullup Current in NPN mode	I_{LDO_LS}	NPN mode, low-side off, $V_{DO} = 0V$	-35	-20	-10	μA	
DO Leakage Current in NPN Mode	I_{DO_LEAK}	$V_{CC} = 24V$, $V_{DO} = 34V$, DO is high impedance			200	μA	
DO Output Negative Clamp Voltage	V_{CLN}	PNP mode, 100mA clamp current flowing into DO		$V_{CC} - 42$		V	
DO Output Positive Clamp Voltage	V_{CLP}	PNP mode, 100mA clamp current flowing into DO		42		V	
LOGIC INPUT SIGNALS (DIN, NPN, NO, PP, LED2IN)							
Input Logic-High Voltage	V_{IH}		2.0			V	
Input Logic-Low Voltage	V_{IL}				0.8	V	
Input Leakage Current	I_{IL}	DIN, NPN, NO, PP, $V_{IN} = 0V$ or $5.5V$	-1		+1	μA	
LED2IN Input Pull-Up Current	I_{PU}	$V_{LED2IN} = 0V$	5	10	15	μA	
LOGIC OUTPUT SIGNAL (FAULT)							
FAULT Output Low Voltage	V_{OL}	$I_{FAULT} = 1mA$			0.4	V	
FAULT Output Leakage	I_{OL}	$V_{FAULT} = 0V$ or $5.5V$, FAULT is three-stated	-1		+1	μA	
LED DRIVER OUTPUTS (LEDS, LED2)							
LED Current Source	I_{LED}	LEDS, LED2 on, $V_{LEDS}/V_{LED2} = 4V$	1.7	2	2.3	mA	

AC Electrical Characteristics

($V_{CC} = 4.75V$ to $34V$ (MAX14839), $V_{CC} = 7V$ to $34V$ (MAX14838), unless otherwise noted. $V_{GND} = 0V$. All logic inputs are V_{LDO} or GND. $T_A = T_{MIN}$ to T_{MAX} . Typical values are at $V_{CC} = 24V$, $T_A = +25^\circ C$) (Notes 1, 2)

PARAMETER	SYMBOL	CONDITIONS	MIN	TYP	MAX	UNITS
LINEAR REGULATOR (LDO)						
Output Voltage	V_{LDO}	MAX14839, $4.75V \leq V_{CC} \leq 34V$, $I_{LDO} = 30mA$	3.0	3.3	3.6	V
		MAX14838, $7V \leq V_{CC} \leq 34V$, $I_{LDO} = 30mA$	4.5	5.0	5.5	
Short Circuit Current Limit	I_{LDO_SC}	LDO short to GND	30	45		mA
Line Regulation		$I_{LDO} = 30mA$		0.06		%
Load Regulation		$0.1mA \leq I_{LOAD} \leq 30mA$, 100nF bypass capacitor on LDO		2.8		Ω
PROTECTION						
Thermal-Shutdown Threshold	T_{SHDN}	Temperature rising, \overline{FAULT} asserted		+150		$^\circ C$
Thermal-Shutdown Hysteresis	T_{SHDN_HYST}			10		$^\circ C$
ESD Protection (V_{CC} , DO, and GND) (Note 4)		Air-Gap Discharge, IEC 61000-4-2		± 8		kV
		Contact Discharge IEC 61000-4-2		± 6		kV
ESD Protection (All Other Pins)		Human Body Model, JESD22-A114E		± 2		kV
Surge Tolerance		IEC 61000-4-5, 0.5 μF /500 Ω		± 1		kV
Reverse Polarity Current	I_{RP}	Any combination of V_{CC} , DO, and GND	-1		+1	mA
POWER-ON RESET TIMING						
POR Delay	t_{PUD}	Delay after V_{CC} rises above V_{TH} until DO is active	75	80	100	ms
DRIVER TIMING						
Low-to-High Propagation Delay	t_{PLH}	$V_{CC} = 34V$, $C_L = 1nF$, $R_L = 10k\Omega$, push-pull or PNP mode, 50% to 50%, Figure 1		5	20	μs
High-to-Low Propagation Delay	t_{PHL}	$V_{CC} = 34V$, $C_L = 1nF$, $R_L = 10k\Omega$, push-pull or NPN mode, 50% to 50%, Figure 1		5	20	μs
DO Output Rise Time	t_{RISE}	$V_{CC} = 34V$, $C_L = 1nF$, $R_L = 10k\Omega$, push-pull or PNP mode, 10% to 90%		6	20	μs
DO Output Fall Time	t_{FALL}	$V_{CC} = 34V$, $C_L = 1nF$, $R_L = 10k\Omega$, push-pull on NPN mode, 90% to 10%		6	20	μs
OVERCURRENT SHUTDOWN TIMING						
Overcurrent Detection Time	t_{ISDET}	(Note 3)	112		150	μs
Overcurrent Turn-Off Time	t_{ISOFF}	(Note 3)	3.75		5.0	ms

Note 1: All units are production tested at $T_A = +25^\circ C$. Specifications over temperature are guaranteed by design.

Note 2: Currents into the device as positive; all currents out of the device are negative. All voltages are referenced to ground, unless otherwise noted.

Note 3: See the [DO Short-Circuit and Overcurrent Protection](#) section for detailed information.

Note 4: ESD protection for V_{CC} is achieved only with an external capacitor connected from V_{CC} to GND. Connect 100nF capacitor between V_{CC} and GND for air-gap and contact discharge ESD.

Test Circuits/Timing Diagrams

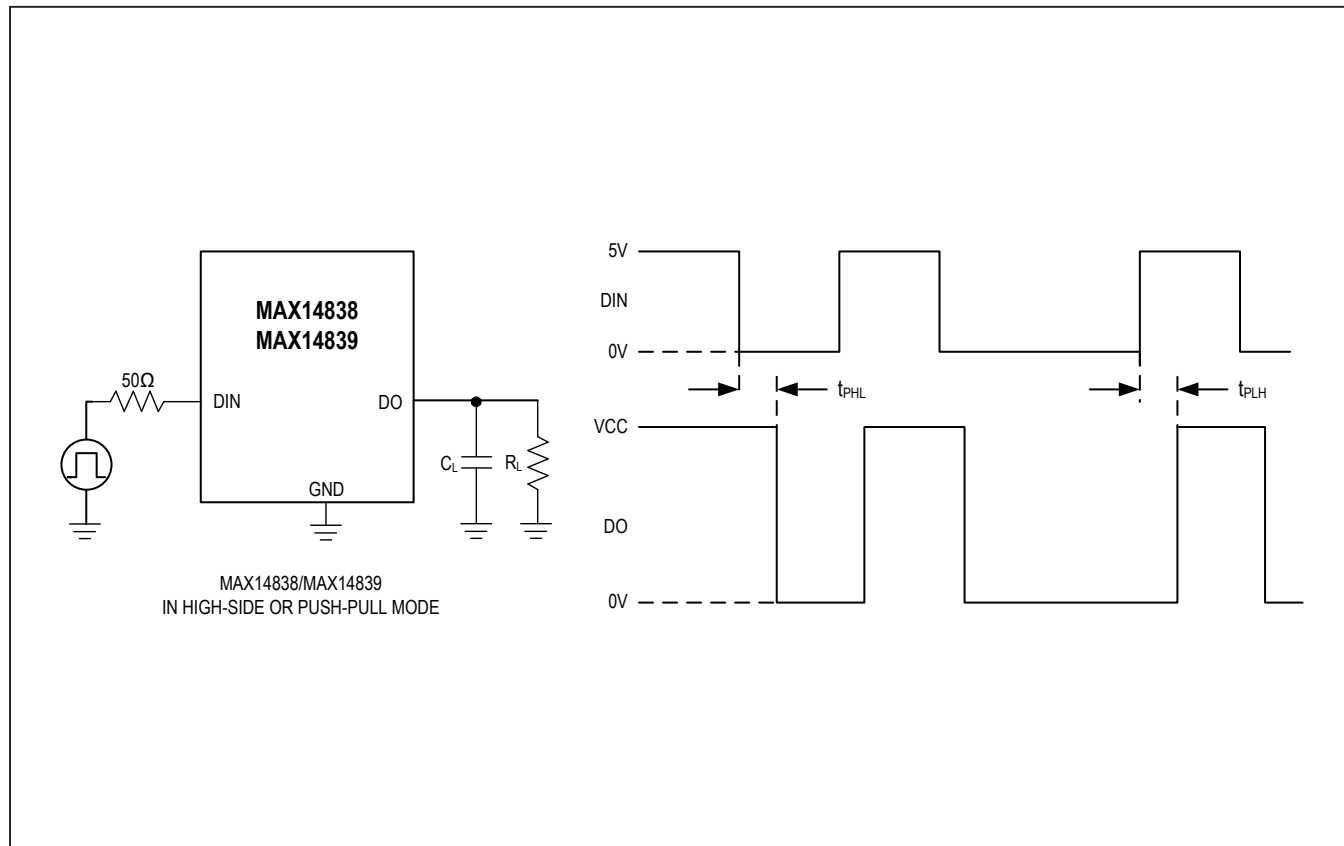
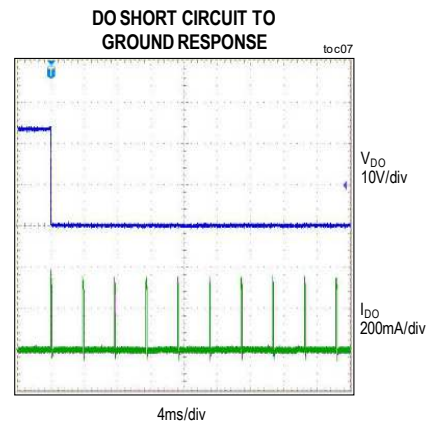
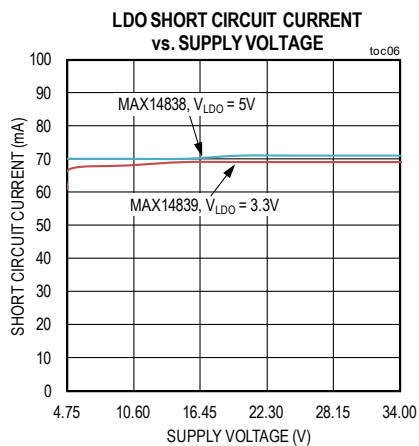
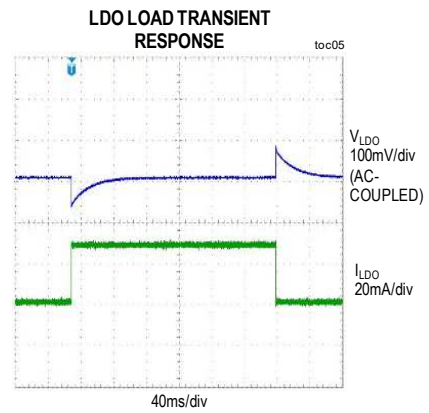
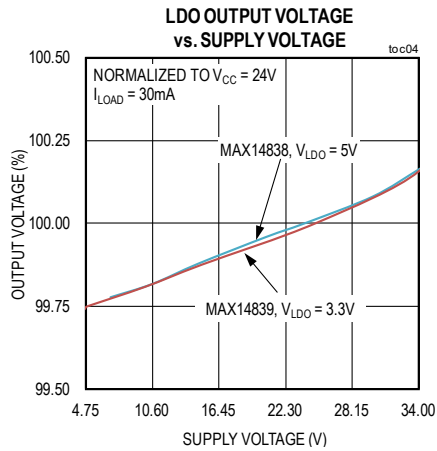
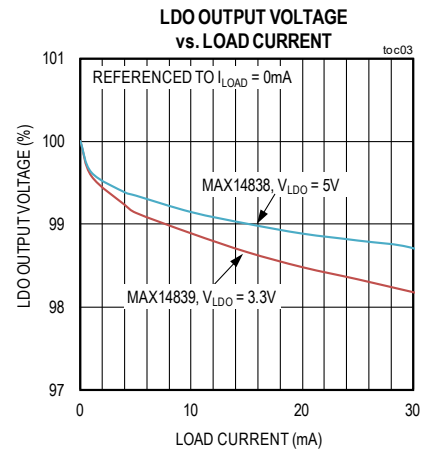
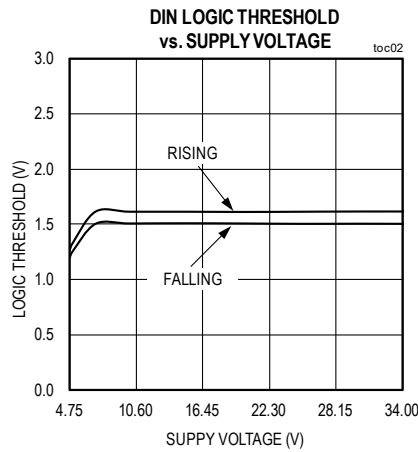
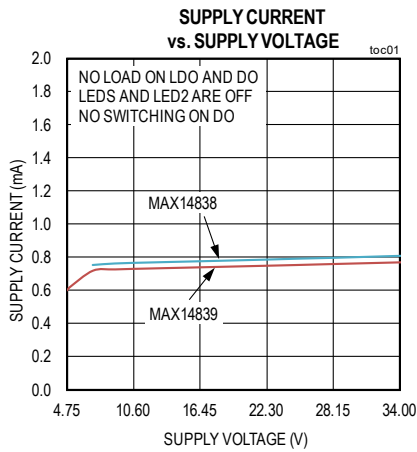

Figure 1. Propagation Delay Timing (NPN, PNP, or Push-Pull Mode)

Typical Operating Characteristics

($V_{CC} = 24V$, $T_A = +25^\circ C$, unless otherwise noted.)



Typical Operating Characteristics

($V_{CC} = 24V$, $T_A = +25^\circ C$, unless otherwise noted.)

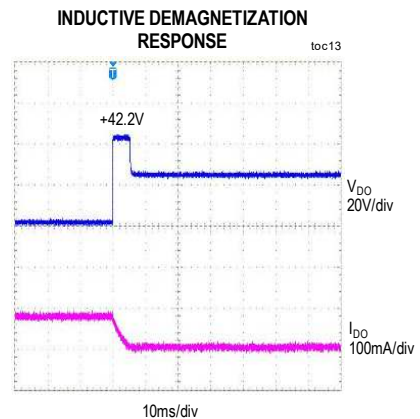
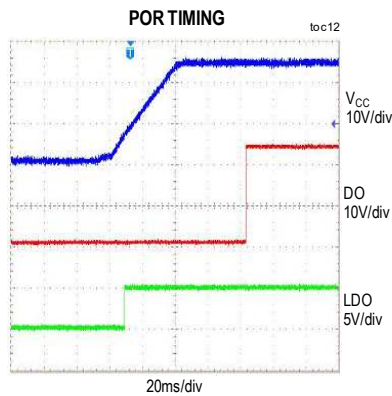
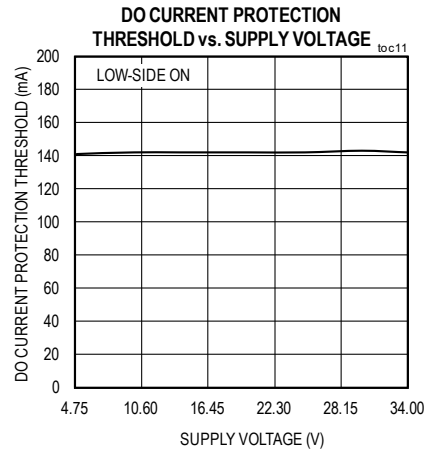
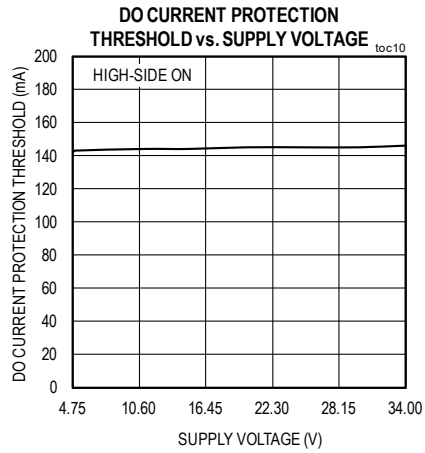
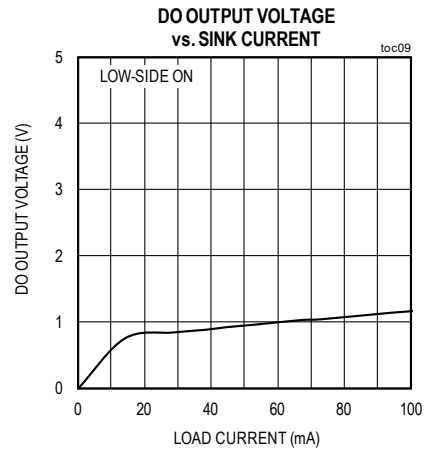
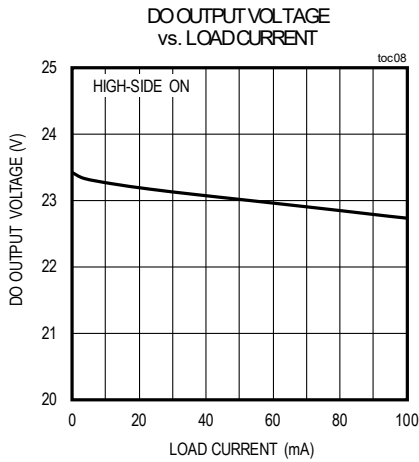

Typical Operating Characteristics

($V_{DD} = 24V$, $T_A = +25^\circ C$, unless otherwise noted.)

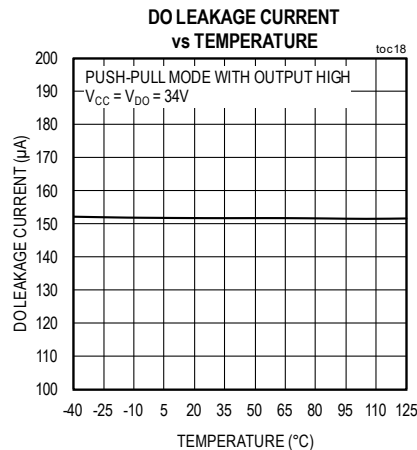
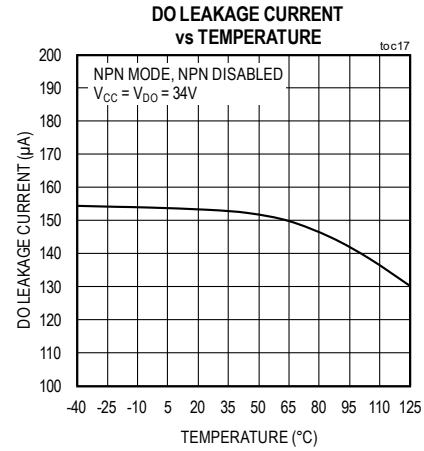
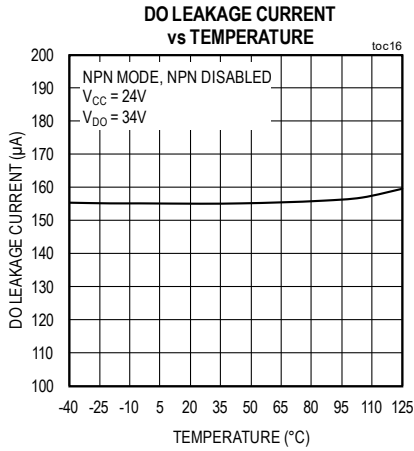
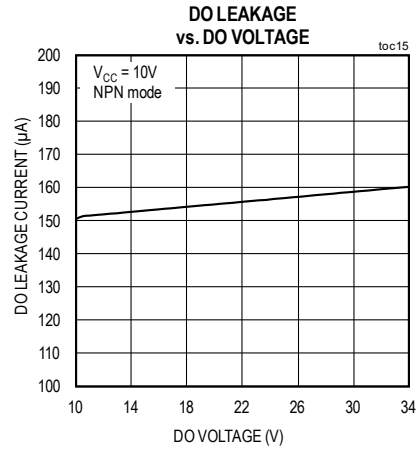
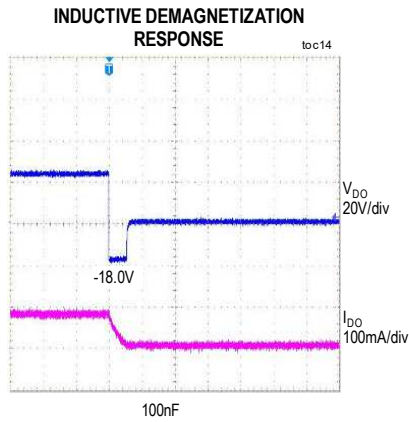

Pin Configuration

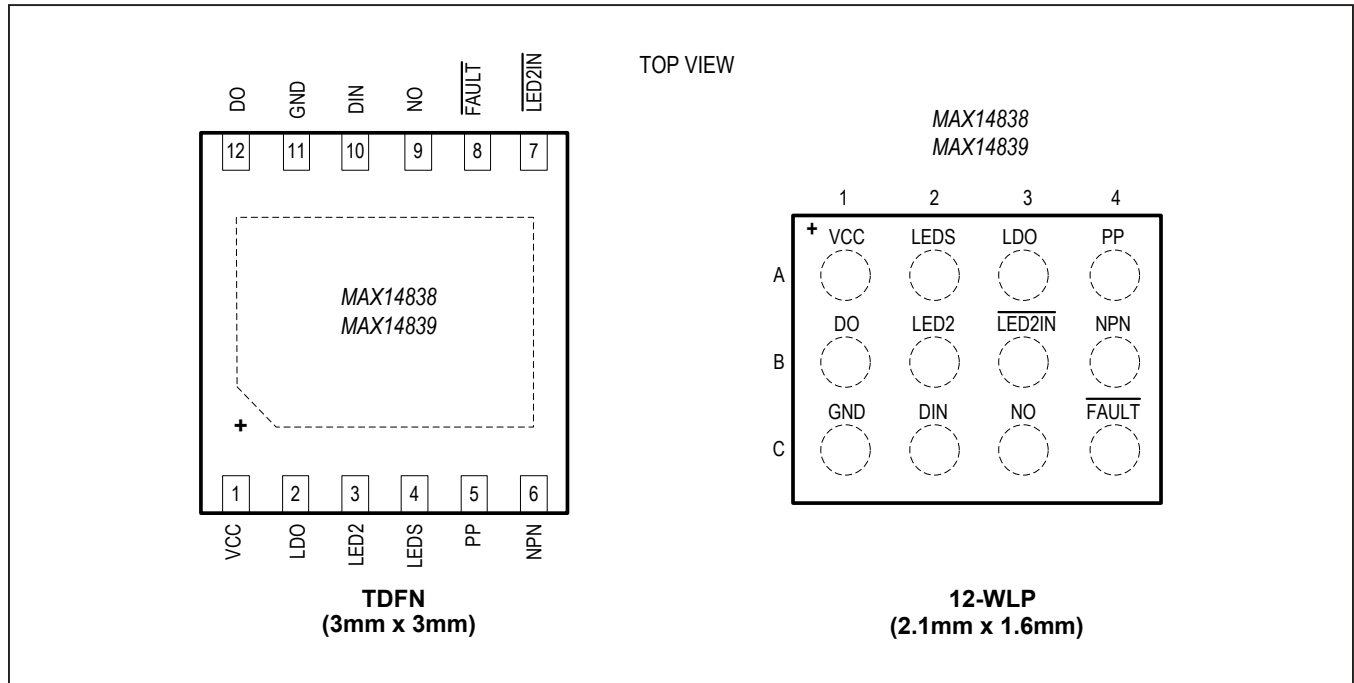

Pin Description

PIN		NAME	FUNCTION
TDFN	WLP		
1	A1	V _{CC}	Power Supply Input. Bypass V _{CC} to GND with a 100nF capacitor as close as possible to the IC.
2	A3	LDO	Linear Regulator Output. V _{LDO} is 5V for the MAX14838. V _{LDO} is 3.3V for the MAX14839. Bypass LDO to GND with a 100nF capacitor as close as possible to the IC.
3	B2	LED2	LED2 Driver Output. Connect LED2 to the anode of an external general purpose LED. LED2 can be left unconnected if not used. See the Truth Table for more information.
4	A2	LEDS	Status LED Driver Output. Connect LEDES to the anode of the status LED and the cathode of the general LED. LEDES may be left unconnected if not used. See the Truth Table .
5	A4	PP	Driver Push-Pull Mode Select Input. See the Truth Table for more information.
6	B4	NPN	Driver NPN or PNP Mode Select Input. See the Truth Table for more information.
7	B3	$\overline{\text{LED2IN}}$	LED2 Control Input. Drive $\overline{\text{LED2IN}}$ low to turn LED2 on. Drive $\overline{\text{LED2IN}}$ high to turn LED2 off. $\overline{\text{LED2IN}}$ can be connected to $\overline{\text{FAULT}}$.
8	C4	$\overline{\text{FAULT}}$	Open-Drain Fault Output. $\overline{\text{FAULT}}$ goes low when an overcurrent or short circuit-condition is detected at DO or when the device is in thermal shutdown.
9	C3	NO	Driver Normally-Open/Normally-Closed Select Input. See the Truth Table for more information.
10	C2	DIN	Driver Input. See the Truth Table for more information.
11	C1	GND	Ground

Pin Description (continued)

PIN		NAME	FUNCTION
TDFN	WLP		
12	B1	DO	Driver Output. See the Truth Table for more information. Connect a 10nF capacitor between DO and GND.
—	—	EP	Exposed Pad. Available on TDFN package only. Connect exposed pad to GND. Not intended as the main ground connection.

Truth Table

INPUTS				OPERATION		
NO	PP	NPN	DIN	MODE	DO STATUS	LEDS
L	L	L	L	PNP NC	ON (High)	ON
L	L	L	H	PNP NC	OFF (High Impedance)	OFF
L	L	H	L	NPN NC	ON (Low)	ON
L	L	H	H	NPN NC	OFF (High Impedance)	OFF
L	H	L	L	Push-Pull NH	HIGH	ON
L	H	L	H	Push-Pull NH	LOW	OFF
L	H	H	L	Push-Pull NL	LOW	ON
L	H	H	H	Push-Pull NL	HIGH	OFF
H	L	L	L	PNP NO	OFF (High Impedance)	OFF
H	L	L	H	PNP NO	ON (High)	ON
H	L	H	L	NPN NO	OFF (High Impedance)	OFF
H	L	H	H	NPN NO	ON (Low)	ON
H	H	L	L	Push-Pull NL	LOW	OFF
H	H	L	H	Push-Pull NL	HIGH	ON
H	H	H	L	Push-Pull NH	HIGH	OFF
H	H	H	H	Push-Pull NH	LOW	ON

Functional Diagram

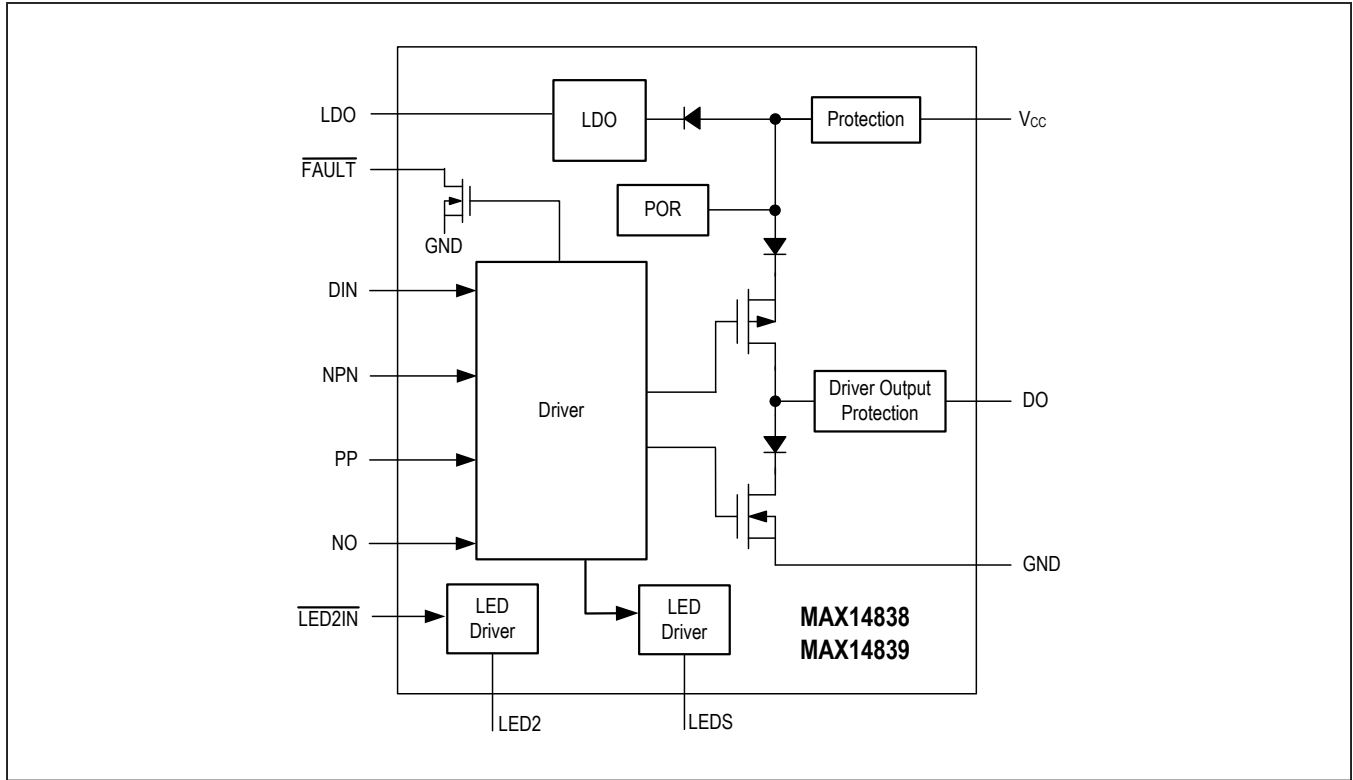

Detailed Description

The MAX14838/MAX14839 are 24V, 100mA drivers for industrial binary sensors. These devices are pin-programmable and integrate the common high-voltage circuitry needed for industrial binary sensors into a single-device solution. Integrated transient protection meets the IEC 61000-4-5 standard and protects surges up to ±1kV/500Ω.

The MAX14838/MAX14839 feature multiple configuration options that are user-selected during operation. The output of the device can be pin-configured for high-side (PNP), low-side (NPN), or push-pull operation. Additionally, the devices allow the user to configure the logic for sensors that are normally open (NO) or normally closed (NC).

The two integrated LED drivers in the MAX14838/MAX14839 provide visual feedback of the state of the sensor.

These devices deliver the robust design necessary in industrial applications. The DO, V_{CC}, and GND interface pins are protected against reverse-polarity connection,

short circuits, and high ESD. These devices also feature fast inductive demagnetization of GND-connected and V_{CC}-connected inductive loads up to 1.5H.

Overcurrent protection guards the MAX14838/MAX14839 from damage due to overheating during overcurrent fault conditions. The FAULT output signals thermal overload and overcurrents.

LDO Linear Regulator

The MAX14838/MAX14839 feature an integrated linear regulator to power external loads up to 30mA, suitable for most common industrial sensors. The MAX14838 features a 5V LDO, while the MAX14839 features a 3.3V LDO. During thermal shutdown, the regulator is turned off.

Power-On Reset (POR)

The MAX14838/MAX14839 includes a 95ms (max) POR delay between the time the supply voltage exceeds the POR threshold until the DO output is enabled. During the POR delay, the DO output is high impedance and the LED drivers (LEDs and LED2) are inactive.

Reverse-Polarity Protection

Reverse-polarity protection is built into the MAX14838/MAX14839. Integrated circuitry protects the device against accidental reverse-polarity connections to the V_{CC}, DO, and GND pins. During a reverse-polarity plugin event, the maximum current drawn through V_{CC}, DO, or GND is 1mA. The maximum voltage between any of the pins must not exceed 36V_{DC} at any time.

Voltage Transients

Short-duration voltage transients that rise above the absolute maximum rating of the V_{CC} pin occur during ESD, burst, and hot plug events. The MAX14838/MAX14839 cannot be damaged with a 100nF bypass capacitor on the V_{CC} line. Transients due to inductive kickback on DO when driving inductive loads up to 1.5H at 100mA or less can also bring the DO voltage above the absolute maximum rating, yet not damage the device. The absolute maximum ratings for V_{CC} and DO should not be violated for any length of time by external sources.

Driver Output (DO)

The driver output of the MAX14838/MAX14839 is pin-configurable for low-side, high-side, or push-pull operation. The driver output can also be configured as normally open or normally closed. See the [Truth Table](#) for details on configuring the output mode.

Fast Turn-Off of Inductive Loads

The MAX14838/MAX14839 contain internal circuitry that enables rapid demagnetization of inductive loads in NPN or PNP modes. Inductive loads up to 1.5H can be magnetized and demagnetized by the MAX14838/MAX14839.

In the case of an inductive load connected to GND ([Figure 2](#)), the inductor is magnetized as DO is driven high. When the DO output switches to the off state, there is a consequential negative voltage kickback on the DO pin, which is shunted to V_{CC} by an internal clamp. The demagnetization voltage across the load for a negative voltage kickback event is |V_{CC} - 42V| (typ). As the voltage supplied to V_{CC} increases, the demagnetization voltage across the inductor decreases. Consequently, the demagnetization time increases with voltage supplied to V_{CC}.

Similarly, with a load connected to V_{CC} ([Figure 3](#)), the inductor is magnetized as DO is driven low. When the DO output switches to the off state, there is a consequential positive voltage kickback at the DO pin, which is shunted to GND by an internal clamp. The demagnetization voltage across the load for a positive voltage kickback event is |V_{CC} - 42V| (typ).

The equivalent clamping structure of the MAX14838/MAX14839 for high-side mode is shown in [Figure 2](#), and the equivalent clamping structure for the device in low-side mode is shown in [Figure 3](#). As shown in the figures, the minimum series load resistor can be calculated as V_{CC}/100mA.

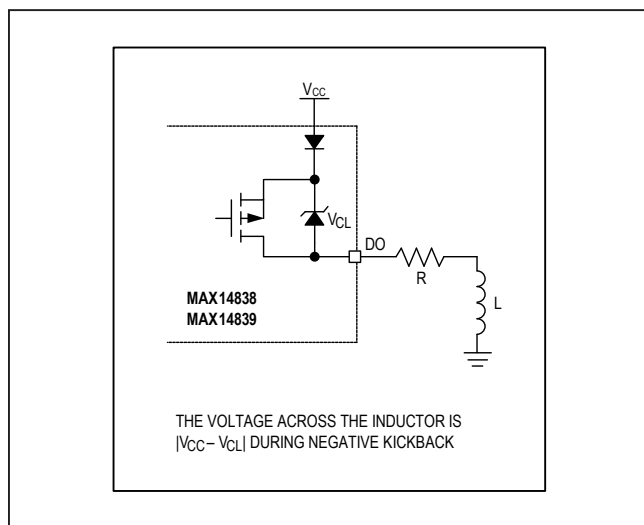

Figure 2. High-Side Mode with Ground-Connected Load

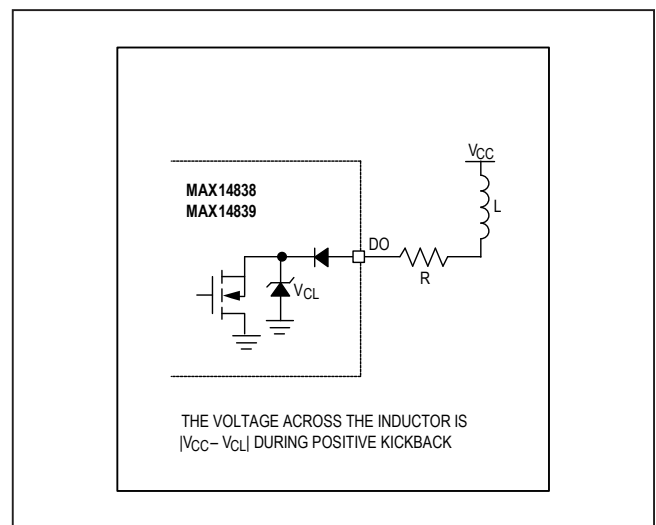

Figure 3. Low-Side Mode with Supply-Connected Load

Capacitive Loads

The MAX14838/MAX14839 are capable of driving capacitive loads on the DO output. Assuming a pure capacitive load without series/parallel resistance, the maximum capacitance that can be charged can be calculated as:

$$C_{LOAD} = [I_{CL} \times t_{SDET}] / V_{CC}$$

Higher capacitive loads can be driven if a series resistor is connected between the DO output and the load. Capacitive loads can be connected to ground or V_{CC} .

DO Short-Circuit and Overcurrent Protection

The DO driver load current is actively limited to I_{CL} (350mA, typ). When the DO load current exceeds the current protection threshold, I_{OC} (145mA, typ), for a duration longer than t_{SDET} (130 μ s, typ), the DO driver is immediately turned off and enters autoretry mode. In autoretry mode, DO is turned off for t_{SOFF} (4ms, typ) and then powered up for t_{SDET} . If the short-circuit condition has not been removed, the cycle repeats. The device turns off for t_{SOFF} , then back on for t_{SDET} , reducing the overall power dissipation at DO.

LED Output Drivers

The MAX14838/MAX14839 allow the user to receive visual feedback of the state of the sensor using two LED driver outputs, LEDS and LED2. The LED drivers protect onboard LEDs against possible reverse-polarity connections on the V_{CC} supply.

If LEDS and LED2 are used, connect as shown in the [Typical Application Circuit](#). When using a low supply voltage, ensure that the sum of the two LED's forward-voltage is less than 4V.

If only LEDS is used, leave $\overline{LED2IN}$ and LED2 unconnected. If only LED2 is used, connect LEDS to ground.

General Purpose LED Driver (LED2)

LED2 is a general-purpose LED driver output. $\overline{LED2IN}$ is the input for LED2. Pull $\overline{LED2IN}$ low to turn on the LED2 output.

To configure LED2 as a visual fault indicator, connect $\overline{LED2IN}$ to FAULT.

Output Driver State Indicator (LEDS)

The LEDS driver output signals the state of the DO driver. LEDS sources current when one DO output transistor is on in PNP or NPN mode. See [Truth Table](#) for more information.

Thermal Shutdown

The MAX14838/MAX14839 includes integrated protection against thermal overload. When the die temperature rises above +150°C (typ), the DO driver, LED drivers, and the linear regulator automatically turn off until the die temperature returns to a safe level.

Applications Information**Burst Protection**

To improve false transitions during burst testing and conducted radiation susceptibility testing, connect a 10nF capacitor between DO and V_{CC} and another between DO and GND.

Extended ESD Protection

ESD-protection structures are incorporated on all pins to protect against electrostatic discharges up to ± 2 kV (HBM) encountered during handling and assembly. V_{CC} , DO, and GND are further protected against ESD up to ± 12 kV (Air-Gap Discharge), and ± 8 kV (Contact Discharge) without damage. The ESD structures withstand high ESD both in normal operation and when the device is powered down. After an ESD event, the devices continue to function without latchup.

ESD Test Conditions

ESD performance depends on a variety of conditions. Contact Maxim for a reliability report that documents test methodology and test results.

Human Body Model

Figure 4 shows the Human Body Model. Figure 5 shows the current waveform it generates when discharged into a low impedance. This model consists of a 100pF capacitor charged to the ESD voltage of interest that is then discharged into the device through a 1.5kΩ resistor.

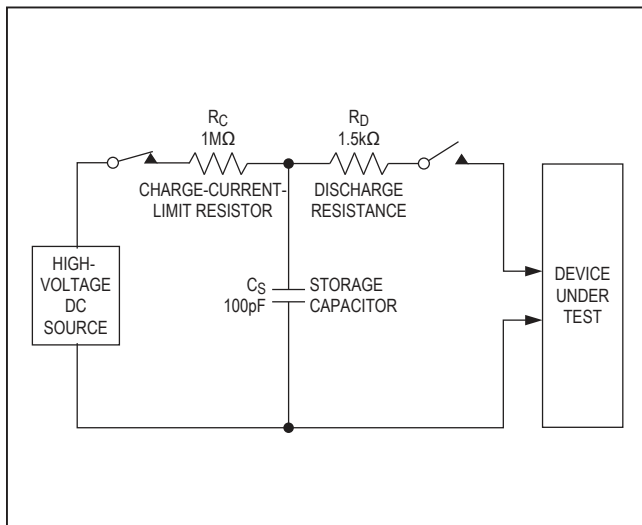

Figure 4. Human Body ESD Test Model

IEC 61000-4-2

The IEC 61000-4-2 standard covers ESD testing and performance of finished equipment. It does not specifically refer to integrated circuits. The major difference between tests done using the HBM and IEC 61000-4-2 is higher peak current in IEC 61000-4-2, because series resistance is lower in the IEC 61000-4-2 model. Hence, the ESD withstand voltage measured to IEC 61000-4-2 is generally lower than that measured using the HBM. Figure 6 shows the IEC 61000-4-2 model and Figure 7 shows the current waveform for the ±8kV, IEC 61000-4-2, Level 4, ESD Contact-Discharge Method.

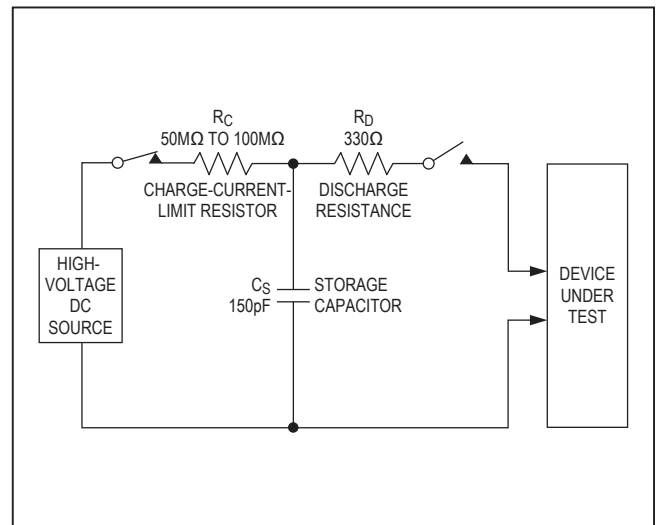

Figure 6. IEC 61000-4-2 ESD Test Model

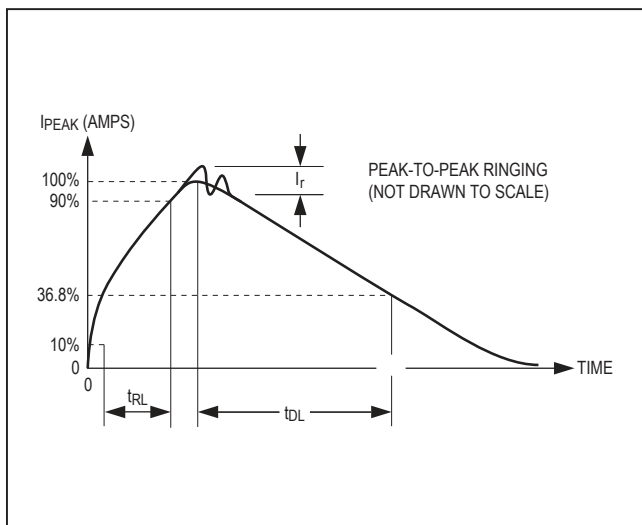

Figure 5. Human Body Current Waveform

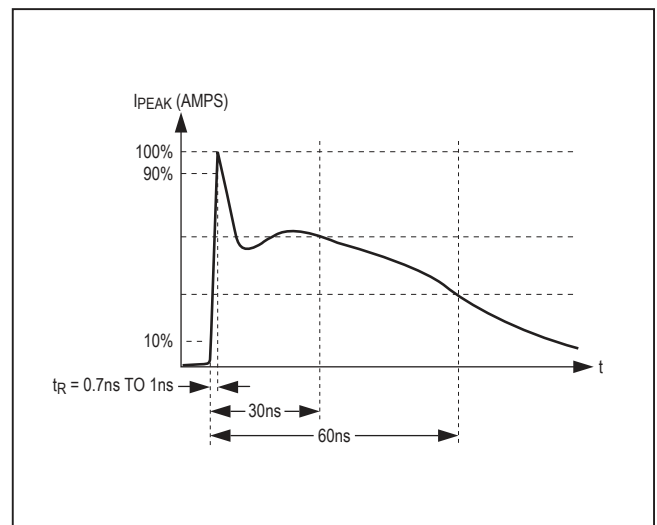
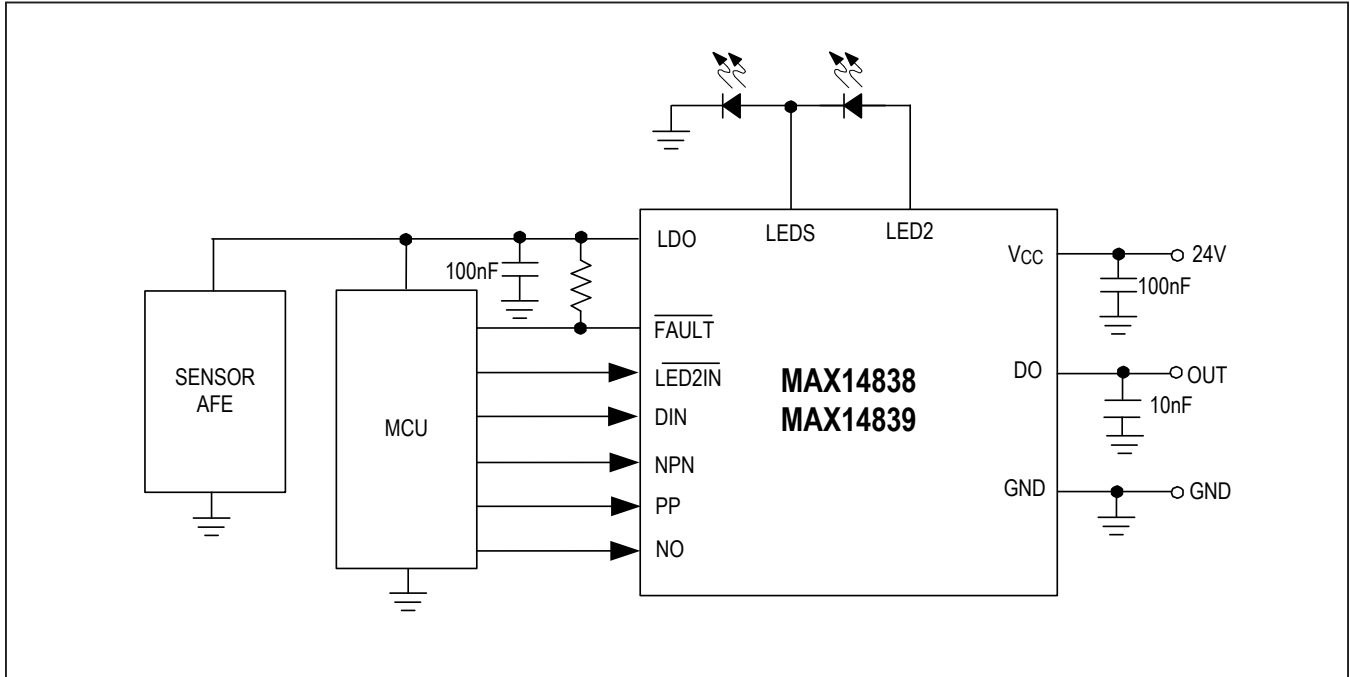

Figure 7. IEC 61000-4-2 ESD Generator Current Waveform

Typical Application Circuit



Ordering Information

PART	LDO VOLTAGE	TEMP RANGE	PIN-PACKAGE
MAX14838GTC+	5V	-40°C to +105°C	12 TDFN-EP
MAX14838GWC+	5V	-40°C to +105°C	12-bump WLP
MAX14839GTC+	3.3V	-40°C to +105°C	12-TDFN-EP
MAX14839GWC+	3.3V	-40°C to +105°C	12-bump WLP

+Denotes a lead(Pb)-free/RoHS-compliant package.

*EP = Exposed pad

Chip Information

PROCESS: BiCMOS

Revision History

REVISION NUMBER	REVISION DATE	DESCRIPTION	PAGES CHANGED
0	12/14	Initial release	—
1	2/15	Updated V_{OH} and V_{OL} limits	2
2	6/15	Updated TOC08 in the <i>Typical Operating Characteristics</i> section	7
3	10/18	Updated the <i>Typical Application Circuits</i> , <i>Pin Description</i> table, and <i>Burst Protection</i> section	1, 10 13, 15

For pricing, delivery, and ordering information, please visit Maxim Integrated's online storefront at <https://www.maximintegrated.com/en/storefront/storefront.html>.

Maxim Integrated cannot assume responsibility for use of any circuitry other than circuitry entirely embodied in a Maxim Integrated product. No circuit patent licenses are implied. Maxim Integrated reserves the right to change the circuitry and specifications without notice at any time. The parametric values (min and max limits) shown in the Electrical Characteristics table are guaranteed. Other parametric values quoted in this data sheet are provided for guidance.