

SECTION C-C

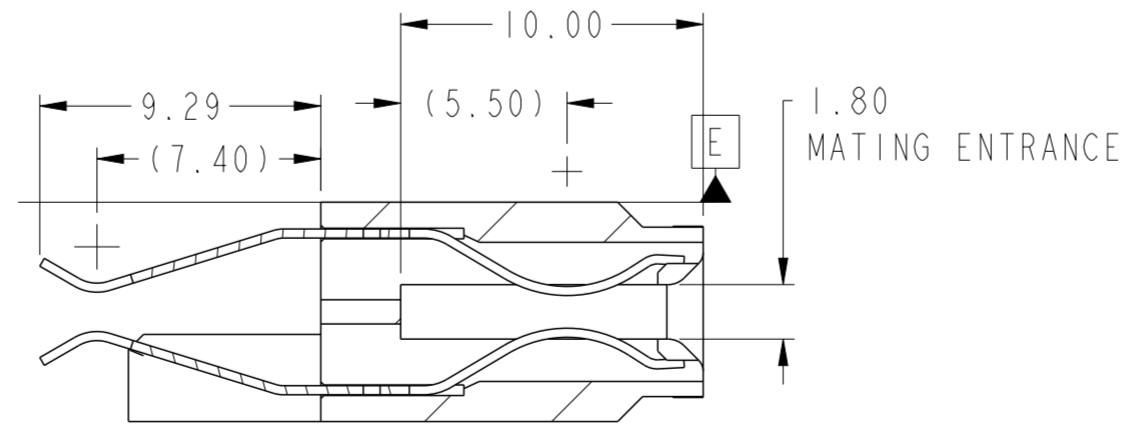

SECTION D-D

spec ref	-	dr	Wei-Long Zhang	2012/08/02	projection	MM	size	A2	scale	4:1
tolerance std	ASME Y14.5	eng	Sunny2 Liu	2016/05/09		CARD EDGE	ecn no	ELX-DG-24036-1	rel level	Released
TOLERANCES UNLESS OTHERWISE SPECIFIED		chr	Terris Liu	2016/05/20			product family	rel level		Released
surface	linear	0.X	±0.5		SMT WITH ENHANCED WALLS HIGH POWER CARD EDGE - UNIVERSAL DRW	cat. no. -	Product - Customer Drw	sheet 1 of 4	rev B	
	0.XX	±0.25								
	0.XXX	±0.10								
	angular	0°	±2°							

PDS: Rev :B

STATUS:Released

Printed: May 24, 2016

Amphenol FCI

© 2016 AFCI

Amphenol FCI

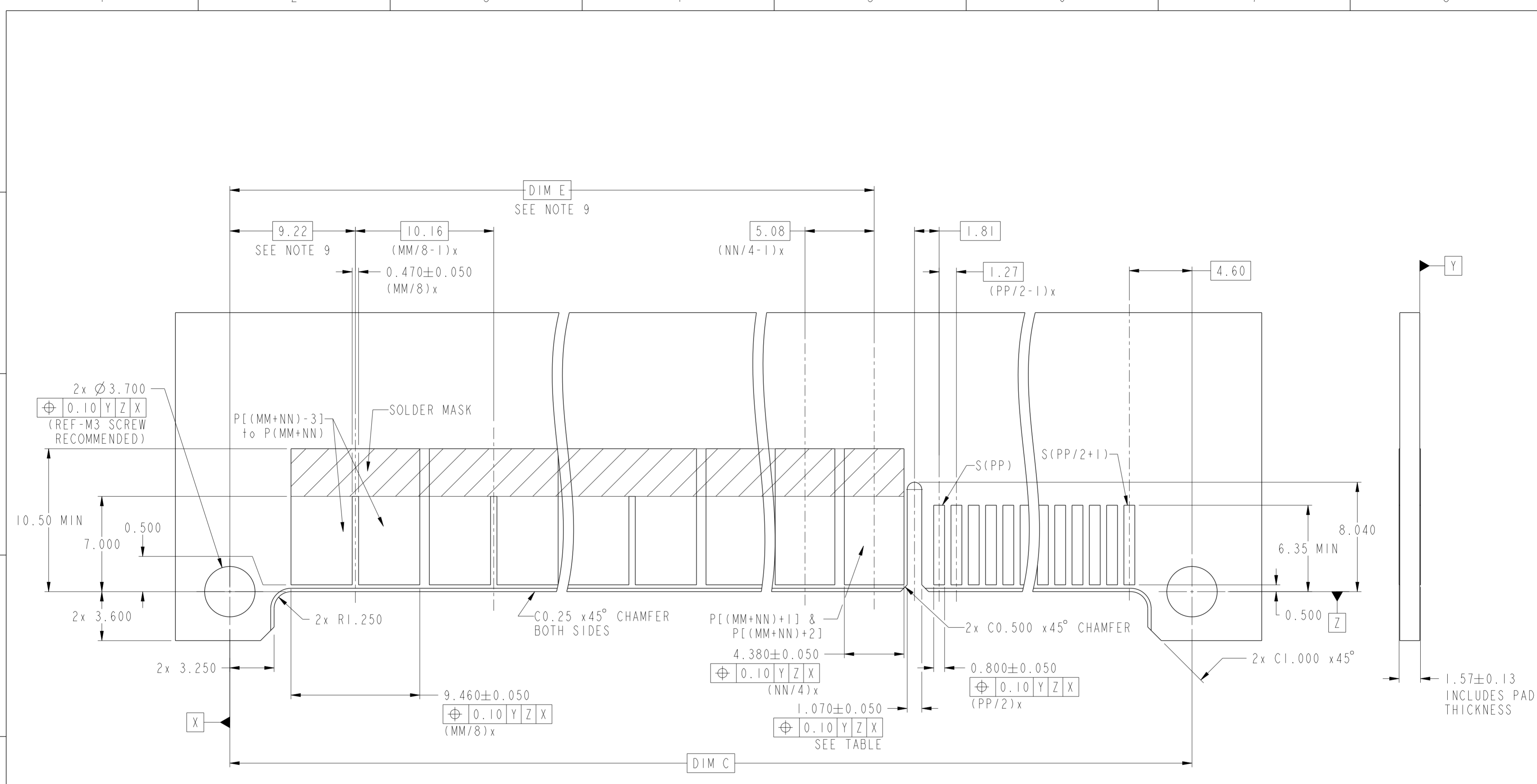

RECOMMENDED HOST BOARD LAYOUT AS VIEWED

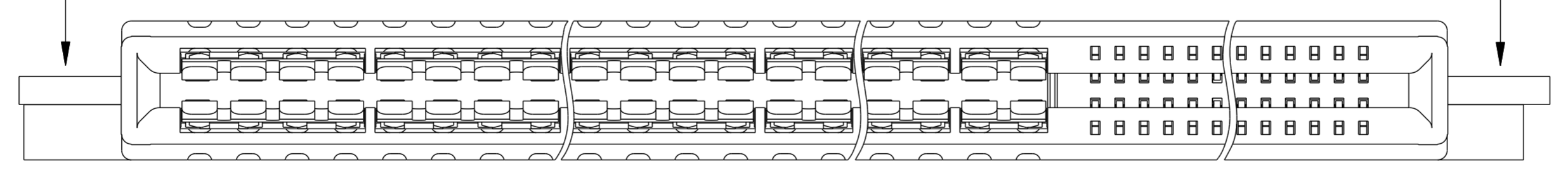

spec ref	-	dr	Wei-Long Zhang	2012/08/02	projection	MM	size	A2	scale	4:1		
tolerance std	ASME Y14.5	eng	Sunny2 Liu	2016/05/09			ecn no	ELX-DG-24036-1	rel level	Released		
TOLERANCES UNLESS OTHERWISE SPECIFIED		chr	Terris Liu	2016/05/20								
		appr	Pai-Ming Zheng	2016/05/24								
surface	ASME Y14.5	linear	0.X	±0.5	Amphenol FCI		product family	SMT WITH ENHANCED WALLS		title HIGH POWER CARD EDGE - UNIVERSAL DRW cat. no.	dwg no 10122238	rev B
		angular	0°	±2°	Product - Customer Drw		sheet 2 of 4					

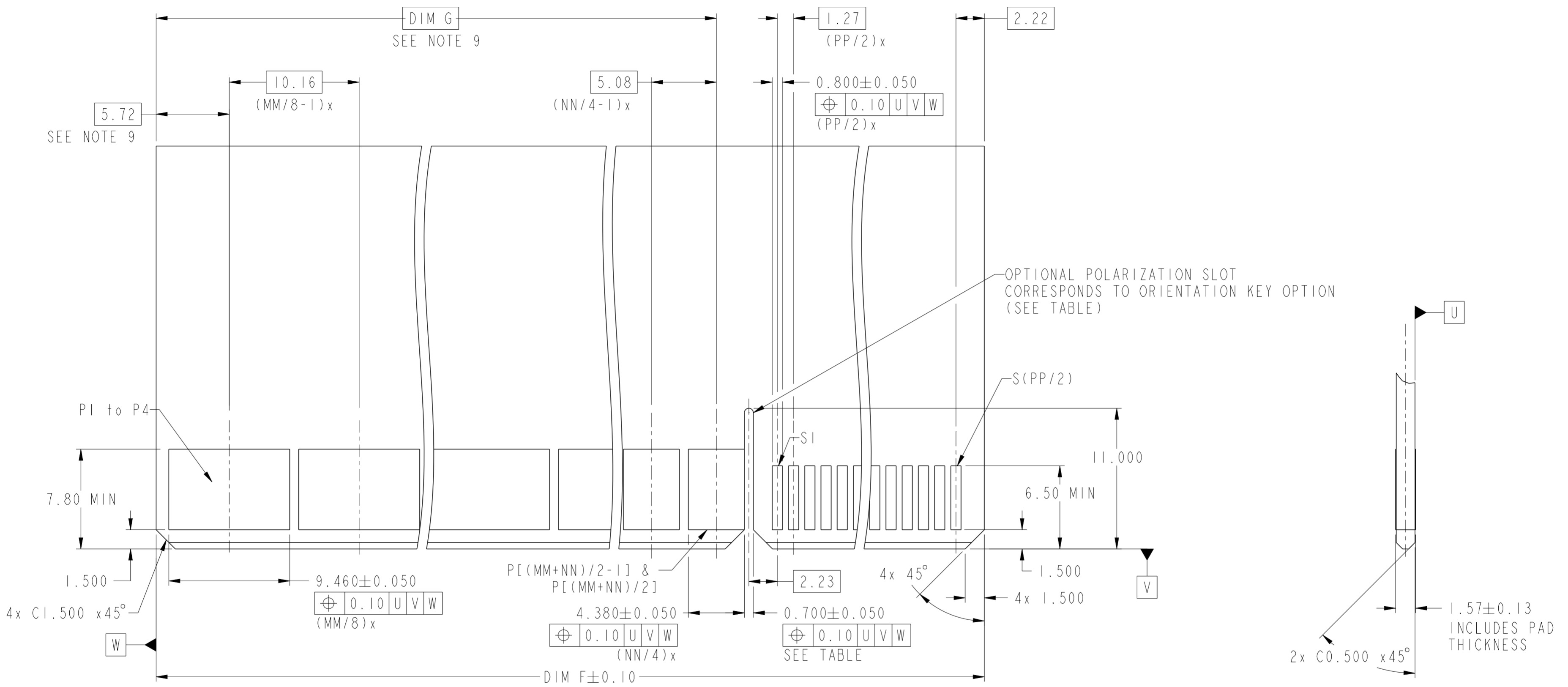

RECOMMENDED MATING BOARD FOOTPRINT

spec ref	-	dr	Wei-Long Zhang	2012/08/02	projection	MM	size	A2	scale	4:1	
tolerance std	ASME Y14.5	eng	Sunny2 Liu	2016/05/09			ecn no	ELX-DG-24036-1			
TOLERANCES UNLESS OTHERWISE SPECIFIED		chr	Terris Liu	2016/05/20			rel level	Released			
surface	ASME Y14.5	appr	Pei-Ming Zheng	2016/05/24			product family	-			
linear	0.X ± 0.5 0.XX ± 0.25 0.XXX ± 0.10	Amphenol FCI		SMT WITH ENHANCED WALLS HIGH POWER CARD EDGE - UNIVERSAL DRW		cat. no.	Product - Customer Drw		sheet 3 of 4	rev	B
angular	0° ± 2°										

10122238 - MM NN PP LF

LEAD FREE

	A	B	C	D	E	F	G	H
MOUNTING EARS	Y	Y	Y	N	N	N	Y	N
POLARIZATION KEY	Y	N	N	Y	N	N	Y	Y
REAR GUIDE	Y	Y	N	Y	Y	N	N	N

QUAD PWR BEAM QTY
(NEXT TO LEFT END)

DUAL PWR BEAM QTY
(NEXT TO SIGNAL)

SIGNAL CONTACT QTY

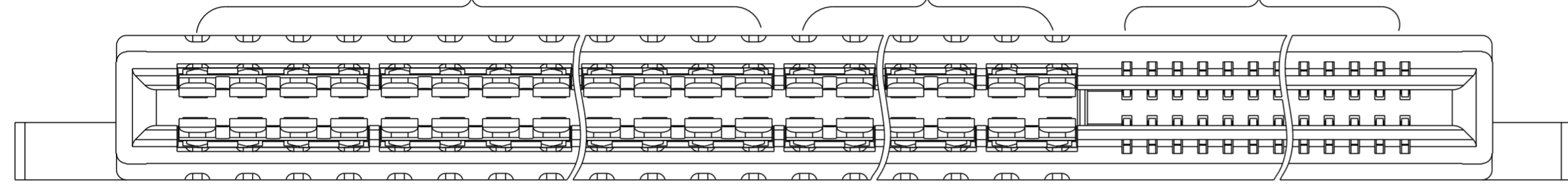

Example: The configuration above is 10122238-241224ALF
STRADDLE MT WITH ENHANCED WALLS 36P24S with MOUNTING EARS,
POLARIZATION KEY and ALIGNMENT KEY.
24P is 4 beam contacts, 12P is 2 beam contacts.

TABLE: PART NUMBER CODE FOR HPCE MT WITH ENHANCED WALLS P+S CONFIG

NOTES:

- CONNECTOR MATERIALS:
HOUSING: HIGH TEMPERATURE THERMAL PLASTIC, BLACK
UL 94V-0 COMPLIANT
CONTACTS: HIGH PERFORMANCE COPPER ALLOY.
- CONTACT FINISH REF. GS-12-604 SECTION 5.2.
- PRODUCT SPECIFICATION: GS-12-604.
- APPLICATION SPECIFICATION: GS-20-128.
- PRODUCT MARKING ON HOUSING IN AREA SHOWN MEETS APCI SPECIFICATION: GS-24-007.
- PACKAGING MEETS FCI SPECIFICATION GS-14-937.
- HOUSING COMPONENT WILL WITHSTAND EXPOSURE TO 260°C PEAK TEMPERATURE FOR 60 SECONDS IN A CONVECTION, INFRA-RED, OR VAPOR PHASE REFLOW OVEN.
- MAXIMUM OVERALL LENGTH IS 100mm.
- DIM IS NOT APPLICABLE IF NO 4 BEAM CONTACT OR 2 BEAM CONTACT.
- A SYMBOL $\triangle B$ WILL BE NEXT TO ANY DIMENSION, VIEW, OR NOTE WHICH HAS BEEN MODIFIED WITH THE CURRENT DRAWING REVISION.

POLARIZATION KEY

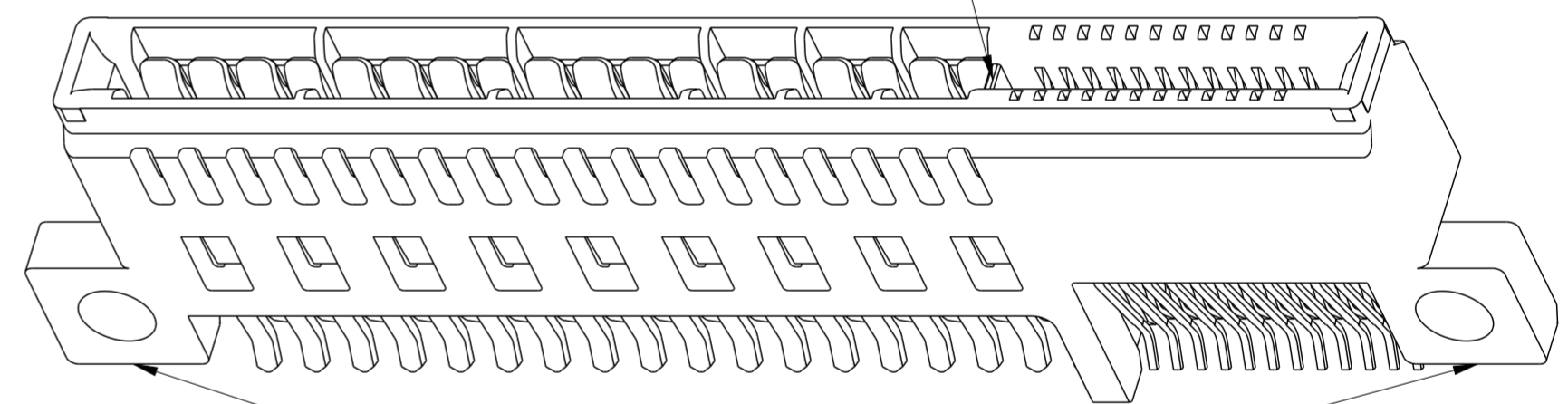

MOUNTING EARS

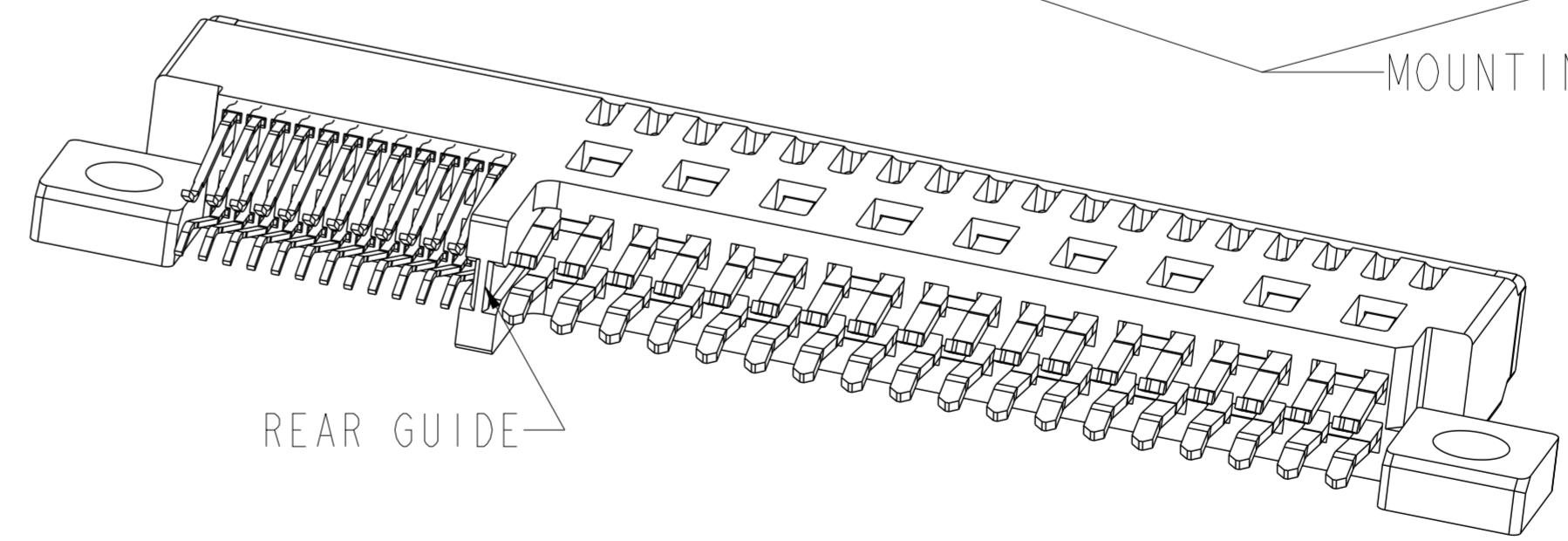

REAR GUIDE

DIM	TABLE 2. LENGTH FORMULAS
DIM A $\text{\textcircled{8}}$	$(MM + NN) / 2 \times 2.54 + (PP / 2) \times 1.27 + 17.2$
DIM B	DIM A - 13.08
DIM C	DIM A - 7.5
DIM D	DIM A - 9.02
DIM E $\text{\textcircled{9}}$	$(MM / 8 - 1) \times 10.16 + (NN / 4 - 1) \times 5.08 + 16.84$ (WITH 4 BEAM CONTACT)
	$(NN / 4 - 1) \times 5.08 + 6.68$ (WITHOUT 4 BEAM CONTACT)
DIM F	DIM A - 13.38
DIM G $\text{\textcircled{9}}$	$(MM / 8 - 1) \times 10.16 + (NN/4 - 1) \times 5.08 + 13.34$ (WITH 4 BEAM CONTACT)
	$(NN / 4 - 1) \times 5.08 + 3.18$ (WITHOUT 4 BEAM CONTACT)

spec ref	-	dr	Wei-Long Zhang	2012/08/02	projection	MM	size	A2	scale	4:1
tolerance std	ASME Y14.5	eng	Sunny2 Liu	2016/05/09		CARD EDGE	ecn no	ELX-DG-24036-1	rel level	Released
TOLERANCES UNLESS OTHERWISE SPECIFIED		chr	Terris Liu	2016/05/20			product family	SMT WITH ENHANCED WALLS		cat. no.
surface	linear	0.X	±0.5		HIGH POWER CARD EDGE - UNIVERSAL DRW		cat. no.	Product - Customer Drw	sheet 4 of 4	
ASME Y14.5	angular	0°	±2°		SMT WITH ENHANCED WALLS		cat. no.	Product - Customer Drw	sheet 4 of 4	
		0.XX	±0.25		HIGH POWER CARD EDGE - UNIVERSAL DRW		cat. no.	Product - Customer Drw	sheet 4 of 4	
		0.XXX	±0.10	HIGH POWER CARD EDGE - UNIVERSAL DRW		cat. no.	Product - Customer Drw	sheet 4 of 4		