



# Aluminum electrolytic capacitors

Snap-in capacitors

**Series/Type:** B43548

**Date:** December 2019

## Long-life grade capacitors

### Applications

- Servo drives
- Frequency converters
- Solar inverters
- Uninterruptible power supplies
- Professional power supplies
- Medical appliances
- Not for automotive applications unless otherwise specified



### Features

- Outstanding ripple current capability
- Improved charge/discharge robustness
- Base cooling available upon request for case sizes with diameters of 30 to 35 mm and lengths of 35 to 55 mm
- Very high CV product, compact
- High reliability
- Extremely improved performance at high frequencies
- Very low ESR at operating conditions above 50 °C
- Optimized internal thermal resistance
- Capacitors with all insulation versions pass the needle flame test according to IEC 60695-11-5 for all flame exposure times up to 120 s
- RoHS-compatible

### Construction

- Rapid charge/discharge-proof, polar
- Aluminum case, fully insulated with PET
- Version with PVC insulation available upon request
- Version with PVC insulation and additional PET insulation cap on terminal side available for insulating the capacitor from the PCB
- Snap-in solder pins to hold component in place on PC-board
- Minus pole marking on case surface
- Minus pole not insulated from case
- Overload protection by safety vent on the case wall

### Terminals

- Standard version with 2 terminals, 2 lengths available: 6.3 and 4.5 mm
- 3 terminals to ensure correct insertion: length 4.5 mm

**Specifications and characteristics in brief**

Rated voltage $V_R$	400 ... 500 V DC				
Surge voltage $V_S$	$1.10 \cdot V_R$				
Rated capacitance $C_R$	68 ... 820 $\mu\text{F}$				
Capacitance tolerance	$\pm 20\% \triangleq M$				
Dissipation factor $\tan \delta$ (20 °C, 120 Hz)	$\tan \delta \leq 0.15$				
Leakage current $I_{\text{leak}}$ (5 min, 20 °C)	$I_{\text{leak}} \leq 0.3 \mu\text{A} \cdot \left( \frac{C_R}{\mu\text{F}} \cdot \frac{V_R}{\text{V}} \right)^{0.7} + 4 \mu\text{A}$				
Self-inductance ESL	Approx. 20 nH				
Useful life <sup>1)</sup> 105 °C; $V_R$ ; $I_{\text{AC,R}}$	> 3000 h	Requirements: $ \Delta C/C  \leq 20\%$ of initial value $\tan \delta \leq 2$ times initial specified limit $I_{\text{leak}} \leq$ initial specified limit			
Voltage endurance test 105 °C; $V_R$	2000 h	Post test requirements: $ \Delta C/C  \leq 10\%$ of initial value $\tan \delta \leq 1.3$ times initial specified limit $I_{\text{leak}} \leq$ initial specified limit			
Rapid charge/discharge $\leq 35$ °C; $\Delta V \leq 150$ V; 6 Hz	> 50 million cycles	Requirements: $ \Delta C/C  \leq 20\%$ of initial value $\tan \delta \leq 2$ times initial specified limit $I_{\text{leak}} \leq$ initial specified limit			
	$V_R = 400 \dots 450$ V				
Vibration resistance test	To IEC 60068-2-6, test Fc: Frequency range 10 Hz ... 55 Hz, displacement amplitude 0.35 mm, acceleration max. 5 g, duration $3 \times 2$ h. Capacitor mounted by its body which is rigidly clamped to the work surface.				
Characteristics at low temperature	Max. impedance ratio at 100 Hz	$V_R$	400 V	450 V	500 V
		$Z_{-25\text{ °C}} / Z_{20\text{ °C}}$	4	5	3
		$Z_{-40\text{ °C}} / Z_{20\text{ °C}}$	14	16	7
IEC climatic category	To IEC 60068-1: $V_R \leq 450$ V DC: 25/105/56 (–25 °C/+105 °C/56 days damp heat test) $V_R = 500$ V DC: 40/105/56 (–40 °C/+105 °C/56 days damp heat test) The capacitors can be operated in the temperature range of –40 °C to +105 °C but the impedance at –40 °C must be taken into consideration.				
Sectional specification	IEC 60384-4				

1) Refer to chapter "General technical information, 5 Useful life" on how to interpret useful life.

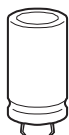

B43548

Outstanding ripple current, compact – 105 °C

### Dimensional drawings

#### Snap-in capacitors with standard insulation (PET)

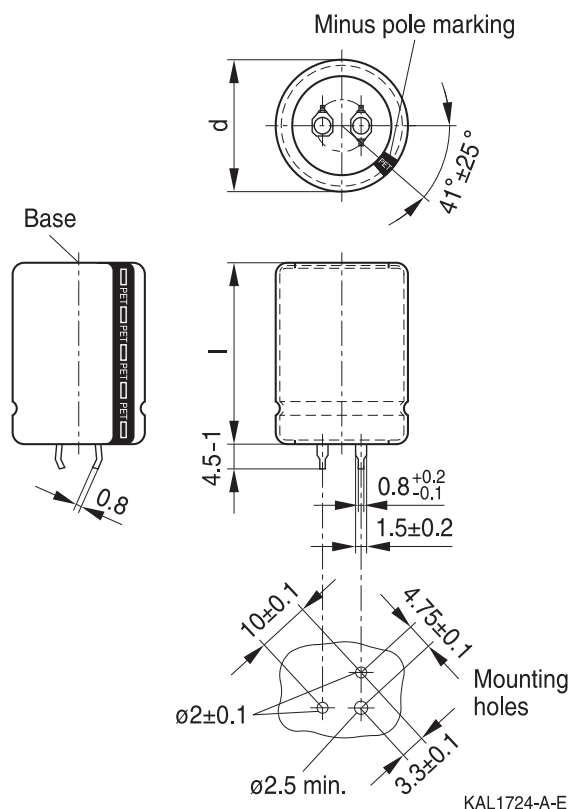
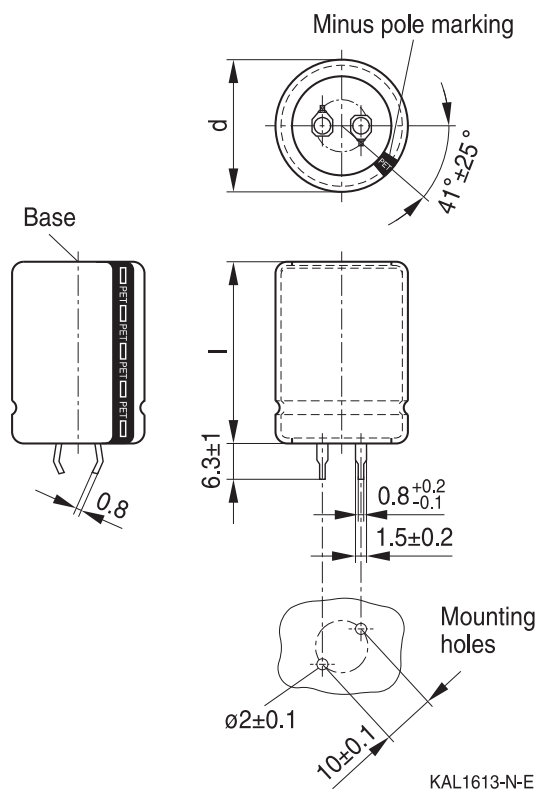

Snap-in terminals, length (6.3 ±1) mm.  
 Also available in a shorter version with a length of (4.5 – 1) mm.  
 Insulation is marked with "PET" on the sleeve.  
 Safety vent on the case wall.

Snap-in capacitors are also available with 3 terminals (length (4.5 – 1) mm).  
 Insulation is marked with "PET" on the sleeve.  
 Safety vent on the case wall.

Dimensions (mm)		Approx. weight(g)	Packing units (pcs.)
d +1	l ±2		
25	25	13	130
25	30	17	130
25	35	19	130
25	40	22	130
25	45	25	130
25	50	29	130
25	55	32	130

Dimensions (mm)		Approx. weight(g)	Packing units (pcs.)
d +1	l ±2		
30	25	17	80
30	30	23	80
30	35	29	80
30	40	36	80
30	45	41	80
30	50	46	80
30	55	53	80
35	25	22	60
35	30	29	60
35	35	36	60
35	40	41	60
35	45	56	60
35	50	70	60
35	55	81	60

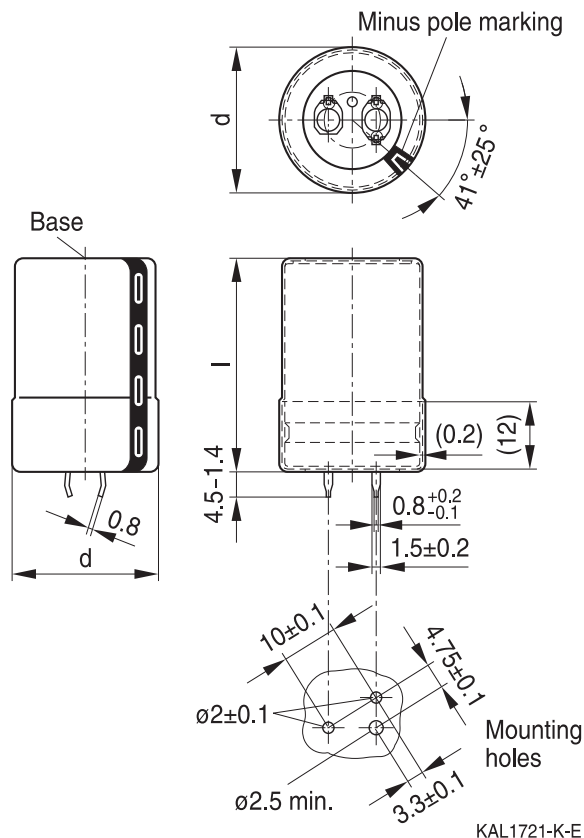
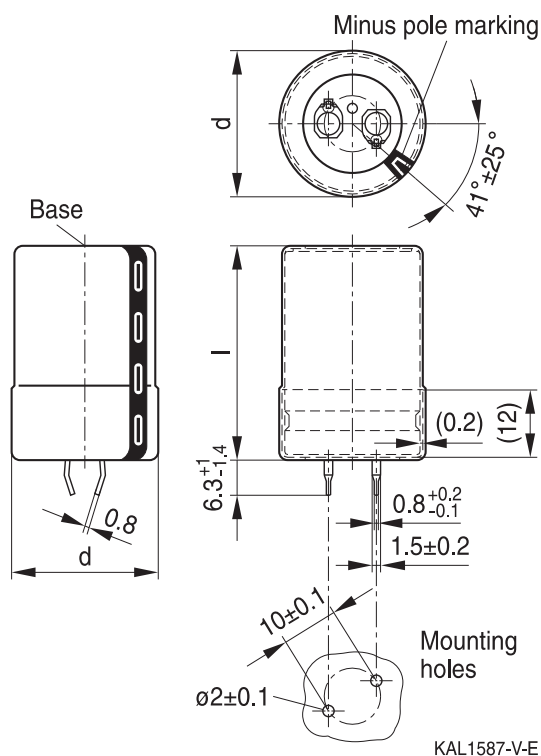

**Snap-in capacitors with PVC insulation and PET insulation cap on terminal side**

Snap-in terminals, length (6.3 +1/–1.4) mm.  
 Also available in a shorter version with a length  
 of (4.5 – 1.4) mm. PET insulation cap is  
 positioned under the insulation sleeve.  
 Safety vent on the case wall.

Snap-in capacitors are also available with  
 3 terminals (length (4.5 – 1.4) mm).  
 PET insulation cap is positioned under the  
 insulation sleeve.  
 Safety vent on the case wall.

Dimensions (mm)		Approx. weight(g)	Packing units (pcs.)
d +1.4	l +2.2/–2		
25	25	13	115
25	30	17	115
25	35	19	115
25	40	22	115
25	45	25	115
25	50	29	115
25	55	32	115

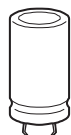
Dimensions (mm)		Approx. weight(g)	Packing units (pcs.)
d +1.4	l +2.2/–2		
30	25	17	80
30	30	23	80
30	35	29	80
30	40	36	80
30	45	41	80
30	50	46	80
30	55	53	80
35	25	22	60
35	30	29	60
35	35	36	60
35	40	41	60
35	45	56	60
35	50	70	60
35	55	81	60



**B43548**

**Outstanding ripple current, compact – 105 °C**

### Packing of snap-in capacitors



For ecological reasons the packing is pure cardboard.

### Ordering codes for terminal styles and insulation features

Identification in 3<sup>rd</sup> block of ordering code

Snap-in capacitors

Terminal version	Insulation version	
	PET	PVC plus PET cap
Standard terminals 6.3 mm	M060	M080
Short terminals 4.5 mm	M067	M087
3 terminals 4.5 mm	M062	M082

Ordering examples:

- B43548A5107M067 } snap-in capacitor with short terminals and PET insulation
- B43548A5107M062 } snap-in capacitor with 3 terminals and PET insulation
- B43548A5107M080 } snap-in capacitor with standard terminals and PVC insulation with additional PET insulation cap on terminal side

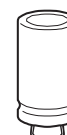

### Overview of available types

The capacitance and voltage ratings listed below are available in different case sizes upon request. Other voltage and capacitance ratings are also available upon request.

$V_R$ (V DC)	400	450	500
	Case dimensions $d \times l$ (mm)		
$C_R$ ( $\mu$ F)			
68			25 × 25
82			25 × 30
100		25 × 25	25 × 35 30 × 25
120	25 × 25	25 × 30	25 × 35 30 × 30
150	25 × 30	25 × 35 30 × 25	25 × 45 30 × 35 35 × 25
180	25 × 35 30 × 25	25 × 40 30 × 30 35 × 25	25 × 50 30 × 35 35 × 30
220	25 × 35 30 × 30	25 × 45 30 × 35 35 × 30	25 × 55 30 × 40 35 × 35
270	25 × 40 30 × 35 35 × 25	25 × 50 30 × 40 35 × 30	30 × 50 35 × 40
330	25 × 50 30 × 35 35 × 30	30 × 45 35 × 35	30 × 55 35 × 45
390	25 × 55 30 × 40 35 × 35	30 × 50 35 × 40	35 × 50
470	30 × 45 35 × 35	30 × 55 35 × 45	35 × 55
560	30 × 55 35 × 40	35 × 50	
680	35 × 50		
820	35 × 55		

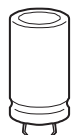

**B43548**

**Outstanding ripple current, compact – 105 °C**

**Technical data and ordering codes**

$C_R$ 100 Hz 20 °C $\mu\text{F}$	Case dimensions $d \times l$ mm	$\text{ESR}_{\text{typ}}$ 100 Hz 20 °C $\text{m}\Omega$	$\text{ESR}_{\text{typ}}$ 300 Hz 60 °C $\text{m}\Omega$	$Z_{\text{max}}$ 10 kHz 20 °C $\text{m}\Omega$	$I_{\text{AC,max}}$ 100 Hz 60 °C A	$I_{\text{AC,max}}$ 100 Hz 85 °C A	$I_{\text{AC,R}}$ 100 Hz 105 °C A	Ordering code (composition see below)
$V_R = 400 \text{ V DC}$								
120	25 × 25	730	190	1070	2.37	1.87	1.17	B43548A9127M0*#
150	25 × 30	580	150	860	2.77	2.18	1.37	B43548A9157M0*#
180	25 × 35	480	120	710	3.16	2.49	1.57	B43548A9187M0*#
180	30 × 25	480	120	710	3.32	2.62	1.64	B43548B9187M0*#
220	25 × 35	400	110	590	3.58	2.82	1.77	B43548A9227M0*#
220	30 × 30	390	100	580	3.80	3.00	1.88	B43548B9227M0*#
270	25 × 40	320	85	480	4.15	3.27	2.05	B43548A9277M0*#
270	30 × 35	320	80	470	4.37	3.45	2.17	B43548B9277M0*#
270	35 × 25	320	80	470	4.55	3.58	2.24	B43548C9277M0*#
330	25 × 50	260	70	390	4.86	3.84	2.41	B43548A9337M0*#
330	30 × 35	260	65	390	4.98	3.92	2.46	B43548B9337M0*#
330	35 × 30	260	65	390	5.21	4.11	2.66	B43548C9337M0*#
390	25 × 55	220	60	340	5.52	4.36	2.73	B43548A9397M0*#
390	30 × 40	220	55	330	5.60	4.42	2.86	B43548B9397M0*#
390	35 × 35	220	55	330	5.84	4.60	2.98	B43548C9397M0*#
470	30 × 45	180	45	280	6.42	5.06	3.28	B43548A9477M0*#
470	35 × 35	180	45	270	6.56	5.17	3.34	B43548B9477M0*#
560	30 × 55	160	40	230	7.35	5.80	3.76	B43548A9567M0*#
560	35 × 40	160	40	230	7.42	5.85	3.79	B43548B9567M0*#
680	35 × 50	130	32	190	8.56	6.75	4.38	B43548A9687M0*#
820	35 × 55	110	26	160	9.80	7.73	5.01	B43548A9827M0*#

**Composition of ordering code**

\* = Insulation feature

6 = PET insulation

8 = PVC insulation with additional PET insulation  
cap on terminal side

# = Terminal style

0 = snap-in standard terminals (6.3 mm)

2 = snap-in 3 terminals (4.5 mm)

7 = snap-in short terminals (4.5 mm)



**Technical data and ordering codes**

$C_R$ 100 Hz 20 °C $\mu\text{F}$	Case dimensions $d \times l$ mm	$\text{ESR}_{\text{typ}}$ 100 Hz 20 °C $\text{m}\Omega$	$\text{ESR}_{\text{typ}}$ 300 Hz 60 °C $\text{m}\Omega$	$Z_{\text{max}}$ 10 kHz 20 °C $\text{m}\Omega$	$I_{\text{AC,max}}$ 100 Hz 60 °C A	$I_{\text{AC,max}}$ 100 Hz 85 °C A	$I_{\text{AC,R}}$ 100 Hz 105 °C A	Ordering code (composition see below)
<b><math>V_R = 450 \text{ V DC}</math></b>								
100	25 × 25	820	210	1200	2.11	1.62	1.04	B43548A5107M0*#
120	25 × 30	680	170	990	2.41	1.85	1.19	B43548A5127M0*#
150	25 × 35	540	140	800	2.82	2.17	1.39	B43548A5157M0*#
150	30 × 25	540	140	790	2.95	2.26	1.45	B43548B5157M0*#
180	25 × 40	450	120	660	3.21	2.47	1.59	B43548A5187M0*#
180	30 × 30	450	110	660	3.34	2.57	1.65	B43548B5187M0*#
180	35 × 25	450	110	660	3.54	2.72	1.75	B43548C5187M0*#
220	25 × 45	370	100	550	3.71	2.85	1.83	B43548A5227M0*#
220	30 × 35	370	90	540	3.84	2.95	1.90	B43548B5227M0*#
220	35 × 30	370	90	540	4.04	3.11	2.04	B43548C5227M0*#
270	25 × 50	300	80	450	4.31	3.31	2.13	B43548A5277M0*#
270	30 × 40	300	75	440	4.42	3.40	2.23	B43548B5277M0*#
270	35 × 30	300	75	440	4.57	3.51	2.30	B43548C5277M0*#
330	30 × 45	240	60	360	5.09	3.91	2.57	B43548A5337M0*#
330	35 × 35	240	60	360	5.25	4.03	2.65	B43548B5337M0*#
390	30 × 50	210	50	310	5.75	4.42	2.90	B43548A5397M0*#
390	35 × 40	210	50	310	5.88	4.52	2.97	B43548B5397M0*#
470	30 × 55	170	45	260	6.61	5.08	3.33	B43548A5477M0*#
470	35 × 45	170	45	250	6.69	5.14	3.38	B43548B5477M0*#
560	35 × 50	140	36	210	7.58	5.82	3.82	B43548A5567M0*#

**Composition of ordering code**

\* = Insulation feature

6 = PET insulation

8 = PVC insulation with additional PET insulation  
cap on terminal side

# = Terminal style

0 = snap-in standard terminals (6.3 mm)

2 = snap-in 3 terminals (4.5 mm)

7 = snap-in short terminals (4.5 mm)

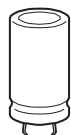

**B43548**

**Outstanding ripple current, compact – 105 °C**

**Technical data and ordering codes**

$C_R$ 100 Hz 20 °C $\mu\text{F}$	Case dimensions $d \times l$ mm	$\text{ESR}_{\text{typ}}$ 100 Hz 20 °C $\text{m}\Omega$	$\text{ESR}_{\text{typ}}$ 300 Hz 60 °C $\text{m}\Omega$	$Z_{\text{max}}$ 10 kHz 20 °C $\text{m}\Omega$	$I_{\text{AC,max}}$ 100 Hz 60 °C A	$I_{\text{AC,max}}$ 100 Hz 85 °C A	$I_{\text{AC,R}}$ 100 Hz 105 °C A	Ordering code (composition see below)
<b><math>V_R = 500 \text{ V DC}</math></b>								
68	25 × 25	1020	270	1440	1.43	1.34	0.78	B43548A6686M0*#
82	25 × 30	840	220	1190	1.73	1.53	0.89	B43548A6826M0*#
100	25 × 35	690	180	980	2.11	1.76	1.02	B43548A6107M0*#
100	30 × 25	690	180	970	2.11	1.84	1.07	B43548B6107M0*#
120	25 × 35	580	150	820	2.53	1.97	1.14	B43548A6127M0*#
120	30 × 30	570	150	810	2.53	2.08	1.21	B43548B6127M0*#
150	25 × 45	460	120	650	3.04	2.34	1.36	B43548A6157M0*#
150	30 × 35	460	120	650	3.14	2.42	1.41	B43548B6157M0*#
150	35 × 25	460	120	660	3.17	2.49	1.44	B43548C6157M0*#
180	25 × 50	390	100	550	3.48	2.68	1.56	B43548A6187M0*#
180	30 × 35	380	100	540	3.53	2.71	1.58	B43548B6187M0*#
180	35 × 30	390	100	550	3.67	2.82	1.68	B43548C6187M0*#
220	25 × 55	320	85	450	4.03	3.10	1.80	B43548A6227M0*#
220	30 × 40	310	80	450	4.07	3.13	1.86	B43548B6227M0*#
220	35 × 35	320	85	450	4.20	3.22	1.92	B43548C6227M0*#
270	30 × 50	260	65	360	4.74	3.64	2.18	B43548A6277M0*#
270	35 × 40	260	70	370	4.80	3.69	2.21	B43548B6277M0*#
330	30 × 55	210	55	300	5.48	4.21	2.52	B43548A6337M0*#
330	35 × 45	210	55	300	5.50	4.23	2.53	B43548B6337M0*#
390	35 × 50	180	50	260	6.18	4.75	2.84	B43548A6397M0*#
470	35 × 55	150	40	210	7.05	5.42	3.23	B43548A6477M0*#

**Composition of ordering code**

\* = Insulation feature

6 = PET insulation

8 = PVC insulation with additional PET insulation  
cap on terminal side

# = Terminal style

0 = snap-in standard terminals (6.3 mm)

2 = snap-in 3 terminals (4.5 mm)

7 = snap-in short terminals (4.5 mm)

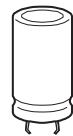

**Useful life<sup>1)</sup>**

For useful life calculations, please use our web-based "AlCap Useful Life Calculation Tool", which can be found on the Internet under the following link:

[www.tdk-electronics.tdk.com/alcap](http://www.tdk-electronics.tdk.com/alcap)

The AlCap Useful Life Calculation Tool provides calculations of useful life as well as additional data for selected capacitor types under operating conditions defined by the user.

In addition, it is possible to calculate useful life expectancies based on temperatures measured by the user in the application.

**Frequency characteristics of ESR**

Typical behavior

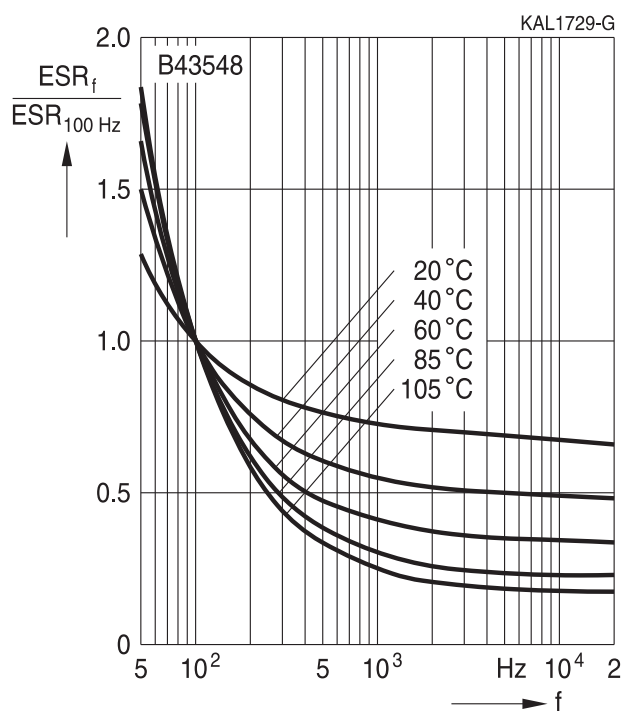

**Impedance Z versus frequency f**

Typical behavior at 20 °C

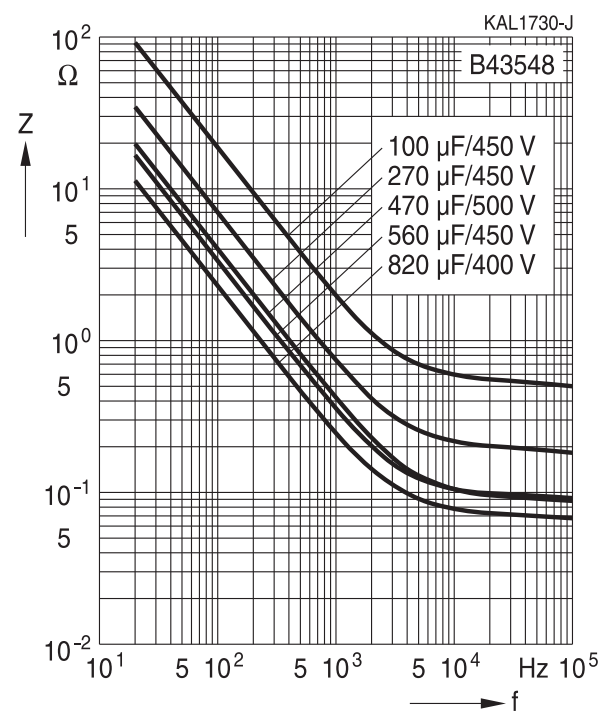

1) Refer to chapter "General technical information, 5 Useful life" on how to interpret useful life.

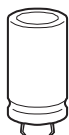

B43548

Outstanding ripple current, compact – 105 °C

## Cautions and warnings

### Personal safety

The electrolytes used have been optimized both with a view to the intended application and with regard to health and environmental compatibility. They do not contain any solvents that are detrimental to health, e.g. dimethyl formamide (DMF) or dimethyl acetamide (DMAC). Furthermore, some of the high-voltage electrolytes used are self-extinguishing.

As far as possible, we do not use any dangerous chemicals or compounds to produce operating electrolytes, although in exceptional cases, such materials must be used in order to achieve specific physical and electrical properties because no alternative materials are currently known. We do, however, restrict the amount of dangerous materials used in our products to an absolute minimum.

Materials and chemicals used in our aluminum electrolytic capacitors are continuously adapted in compliance with the TDK Electronics Corporate Environmental Policy and the latest EU regulations and guidelines such as RoHS, REACH/SVHC, GADSL, and ELV.

MDS (Material Data Sheets) are available on our website for all types listed in the data book. MDS for customer specific capacitors are available upon request.

MSDS (Material Safety Data Sheets) are available for our electrolytes upon request.

Nevertheless, the following rules should be observed when handling aluminum electrolytic capacitors: No electrolyte should come into contact with eyes or skin. If electrolyte does come into contact with the skin, wash the affected areas immediately with running water. If the eyes are affected, rinse them for 10 minutes with plenty of water. If symptoms persist, seek medical treatment. Avoid inhaling electrolyte vapor or mists. Workplaces and other affected areas should be well ventilated. Clothing that has been contaminated by electrolyte must be changed and rinsed in water.



## Product safety

The table below summarizes the safety instructions that must be observed without fail. A detailed description can be found in the relevant sections of separate file chapter "General technical information".

Topic	Safety information	Reference chapter "General technical information"
Polarity	Make sure that polar capacitors are connected with the right polarity.	1 "Basic construction of aluminum electrolytic capacitors"
Reverse voltage	Voltages of opposite polarity should be prevented by connecting a diode.	3.1.6 "Reverse voltage"
Mounting position of screw-terminal capacitors	Screw terminal capacitors must not be mounted with terminals facing down unless otherwise specified.	11.1. "Mounting positions of capacitors with screw terminals"
Robustness of terminals	The following maximum tightening torques must not be exceeded when connecting screw terminals: M5: 2.5 Nm M6: 4.0 Nm	11.3 "Mounting torques"
Mounting of single-ended capacitors	The internal structure of single-ended capacitors might be damaged if excessive force is applied to the lead wires. Avoid any compressive, tensile or flexural stress. Do not move the capacitor after soldering to PC board. Do not pick up the PC board by the soldered capacitor. Do not insert the capacitor on the PC board with a hole space different to the lead space specified.	11.4 "Mounting considerations for single-ended capacitors"
Soldering	Do not exceed the specified time or temperature limits during soldering.	11.5 "Soldering"
Soldering, cleaning agents	Do not allow halogenated hydrocarbons to come into contact with aluminum electrolytic capacitors.	11.6 "Cleaning agents"
Upper category temperature	Do not exceed the upper category temperature.	7.2 "Maximum permissible operating temperature"
Passive flammability	Avoid external energy, e.g. fire.	8.1 "Passive flammability"

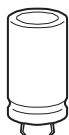

**B43548**

**Outstanding ripple current, compact – 105 °C**

Topic	Safety information	Reference chapter "General technical information"
Active flammability	Avoid overload of the capacitors.	8.2 "Active flammability"
Maintenance	Make periodic inspections of the capacitors. Before the inspection, make sure that the power supply is turned off and carefully discharge the capacitors. Do not apply excessive mechanical stress to the capacitor terminals when mounting.	10 "Maintenance"
Storage	Do not store capacitors at high temperatures or high humidity. Capacitors should be stored at +5 to +35 °C and a relative humidity of ≤ 75%.	7.3 "Shelf life and storage conditions"
		Reference chapter "Capacitors with screw terminals"
Breakdown strength of insulating sleeves	Do not damage the insulating sleeve, especially when ring clips are used for mounting.	"Screw terminals – accessories"

**Display of ordering codes for TDK Electronics products**

The ordering code for one and the same product can be represented differently in data sheets, data books, other publications, on the company website, or in order-related documents such as shipping notes, order confirmations and product labels. The varying representations of the ordering codes are due to different processes employed and do not affect the specifications of the respective products.

Detailed information can be found on the Internet under [www.tdk-electronics.tdk.com/orderingcodes](http://www.tdk-electronics.tdk.com/orderingcodes).

**Symbols and terms**

Symbol	English	German
C	Capacitance	Kapazität
$C_R$	Rated capacitance	Nennkapazität
$C_S$	Series capacitance	Serienkapazität
$C_{S,T}$	Series capacitance at temperature T	Serienkapazität bei Temperatur T
$C_f$	Capacitance at frequency f	Kapazität bei Frequenz f
d	Case diameter, nominal dimension	Gehäusedurchmesser, Nennmaß
$d_{max}$	Maximum case diameter	Maximaler Gehäusedurchmesser
ESL	Self-inductance	Eigeninduktivität
ESR	Equivalent series resistance	Ersatzserienwiderstand
$ESR_f$	Equivalent series resistance at frequency f	Ersatzserienwiderstand bei Frequenz f
$ESR_T$	Equivalent series resistance at temperature T	Ersatzserienwiderstand bei Temperatur T
f	Frequency	Frequenz
I	Current	Strom
$I_{AC}$	Alternating current (ripple current)	Wechselstrom
$I_{AC,RMS}$	Root-mean-square value of alternating current	Wechselstrom, Effektivwert
$I_{AC,f}$	Ripple current at frequency f	Wechselstrom bei Frequenz f
$I_{AC,max}$	Maximum permissible ripple current	Maximal zulässiger Wechselstrom
$I_{AC,R}$	Rated ripple current	Nennwechselstrom
$I_{leak}$	Leakage current	Reststrom
$I_{leak,op}$	Operating leakage current	Betriebsreststrom
l	Case length, nominal dimension	Gehäuselänge, Nennmaß
$l_{max}$	Maximum case length (without terminals and mounting stud)	Maximale Gehäuselänge (ohne Anschlüsse und Gewindebolzen)
R	Resistance	Widerstand
$R_{ins}$	Insulation resistance	Isolationswiderstand
$R_{symm}$	Balancing resistance	Symmetrierwiderstand
T	Temperature	Temperatur
$\Delta T$	Temperature difference	Temperaturdifferenz
$T_A$	Ambient temperature	Umgebungstemperatur
$T_C$	Case temperature	Gehäusetemperatur
$T_B$	Capacitor base temperature	Temperatur des Gehäusebodens
t	Time	Zeit
$\Delta t$	Period	Zeitraum
$t_b$	Service life (operating hours)	Brauchbarkeitsdauer (Betriebszeit)

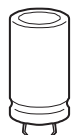

**B43548**

**Outstanding ripple current, compact – 105 °C**

Symbol	English	German
V	Voltage	Spannung
V <sub>F</sub>	Forming voltage	Formierspannung
V <sub>op</sub>	Operating voltage	Betriebsspannung
V <sub>R</sub>	Rated voltage, DC voltage	Nennspannung, Gleichspannung
V <sub>S</sub>	Surge voltage	Spitzenspannung
X <sub>C</sub>	Capacitive reactance	Kapazitiver Blindwiderstand
X <sub>L</sub>	Inductive reactance	Induktiver Blindwiderstand
Z	Impedance	Scheinwiderstand
Z <sub>T</sub>	Impedance at temperature T	Scheinwiderstand bei Temperatur T
tan δ	Dissipation factor	Verlustfaktor
λ	Failure rate	Ausfallrate
ε <sub>0</sub>	Absolute permittivity	Elektrische Feldkonstante
ε <sub>r</sub>	Relative permittivity	Dielektrizitätszahl
ω	Angular velocity; 2 · π · f	Kreisfrequenz; 2 · π · f

**Note**

All dimensions are given in mm.



## Important notes

The following applies to all products named in this publication:

1. Some parts of this publication contain **statements about the suitability of our products for certain areas of application**. These statements are based on our knowledge of typical requirements that are often placed on our products in the areas of application concerned. We nevertheless expressly point out **that such statements cannot be regarded as binding statements about the suitability of our products for a particular customer application**. As a rule, we are either unfamiliar with individual customer applications or less familiar with them than the customers themselves. For these reasons, it is always ultimately incumbent on the customer to check and decide whether a product with the properties described in the product specification is suitable for use in a particular customer application.
2. We also point out that **in individual cases, a malfunction of electronic components or failure before the end of their usual service life cannot be completely ruled out in the current state of the art, even if they are operated as specified**. In customer applications requiring a very high level of operational safety and especially in customer applications in which the malfunction or failure of an electronic component could endanger human life or health (e.g. in accident prevention or lifesaving systems), it must therefore be ensured by means of suitable design of the customer application or other action taken by the customer (e.g. installation of protective circuitry or redundancy) that no injury or damage is sustained by third parties in the event of malfunction or failure of an electronic component.
3. **The warnings, cautions and product-specific notes must be observed.**
4. In order to satisfy certain technical requirements, **some of the products described in this publication may contain substances subject to restrictions in certain jurisdictions (e.g. because they are classed as hazardous)**. Useful information on this will be found in our Material Data Sheets on the Internet ([www.tdk-electronics.tdk.com/material](http://www.tdk-electronics.tdk.com/material)). Should you have any more detailed questions, please contact our sales offices.
5. We constantly strive to improve our products. Consequently, **the products described in this publication may change from time to time**. The same is true of the corresponding product specifications. Please check therefore to what extent product descriptions and specifications contained in this publication are still applicable before or when you place an order. We also **reserve the right to discontinue production and delivery of products**. Consequently, we cannot guarantee that all products named in this publication will always be available. The aforementioned does not apply in the case of individual agreements deviating from the foregoing for customer-specific products.
6. Unless otherwise agreed in individual contracts, **all orders are subject to our General Terms and Conditions of Supply**.

## Important notes

7. **Our manufacturing sites serving the automotive business apply the IATF 16949 standard.** The IATF certifications confirm our compliance with requirements regarding the quality management system in the automotive industry. Referring to customer requirements and customer specific requirements (“CSR”) TDK always has and will continue to have the policy of respecting individual agreements. Even if IATF 16949 may appear to support the acceptance of unilateral requirements, we hereby like to emphasize that **only requirements mutually agreed upon can and will be implemented in our Quality Management System.** For clarification purposes we like to point out that obligations from IATF 16949 shall only become legally binding if individually agreed upon.
8. The trade names EPCOS, CeraCharge, CeraDiode, CeraLink, CeraPad, CeraPlas, CSMP, CTVS, DeltaCap, DigiSiMic, ExoCore, FilterCap, FormFit, LeaXield, MiniBlue, MiniCell, MKD, MKK, MotorCap, PCC, PhaseCap, PhaseCube, PhaseMod, PhiCap, PowerHap, PQSine, PQvar, SIFERRIT, SIFI, SIKOREL, SilverCap, SIMDAD, SiMic, SIMID, SineFormer, SIOV, ThermoFuse, WindCap are **trademarks registered or pending** in Europe and in other countries. Further information will be found on the Internet at [www.tdk-electronics.tdk.com/trademarks](http://www.tdk-electronics.tdk.com/trademarks).

Release 2018-10