

THE INFORMATION CONTAINED HEREIN IS CONSIDERED 'PROPRIETARY' TO BEL FUSE INC. AND SHALL NOT BE COPIED, REPRODUCED OR DISCLOSED WITHOUT THE WRITTEN APPROVAL OF BEL FUSE INC.

RoHS



SCHEMATIC

ELECTRICAL SPECIFICATION @25°C

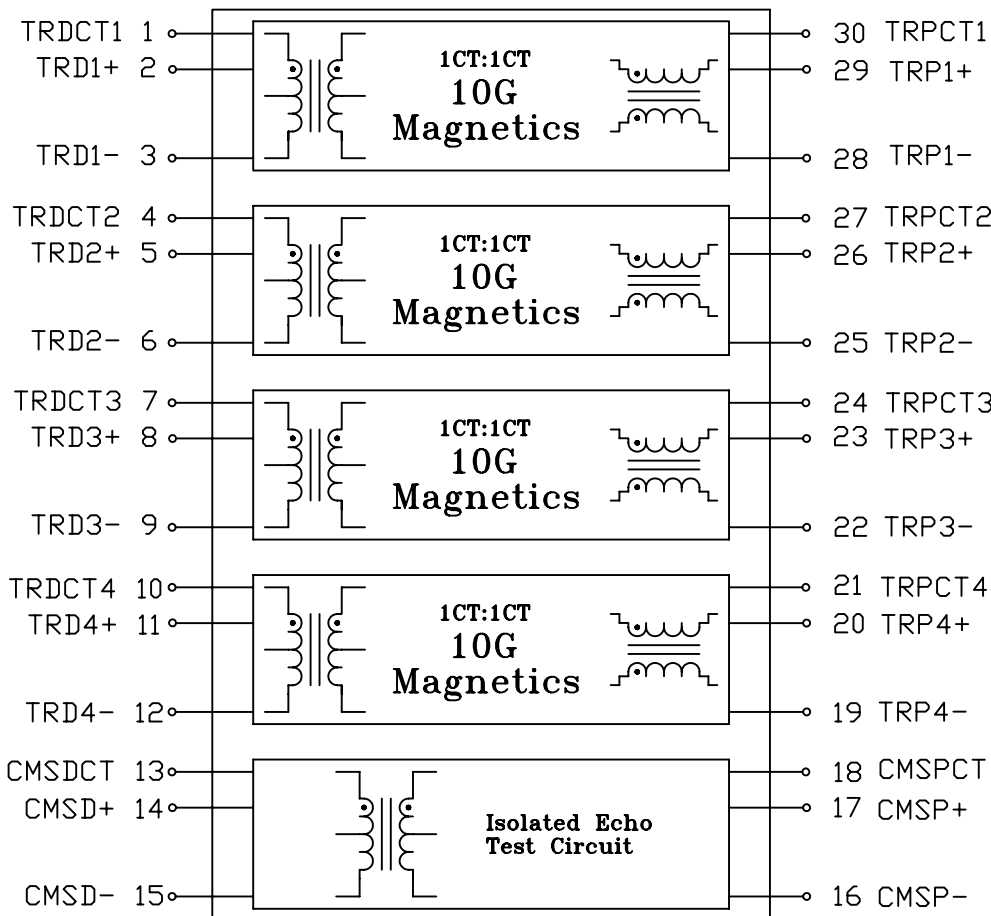

TURNS RATIO
 (2-1-3) : (29-30-29) 1CT : 1CT
 (5-4-6) : (26-27-25) 1CT : 1CT
 (8-7-9) : (23-24-22) 1CT : 1CT
 (11-10-12) : (20-21-19) 1CT : 1CT
 (14-13-15) : (17-18-16) 1CT : 1CT

□CL (16-17) 80uH MIN

POLARITY 2°&29°, 5°&26°
 8°&23°, 11°&20°, 14°&17°

INSERTION LOSS

FREQ(MHz)	1	2-300	400	500
dB MAX	0.3	1.0	1.5	2.0

RETURN LOSS

FREQ(MHz)	1-100	200	300	400	500	600
dB MIN	20	18	17	15.5	12.5	10

CM TO DM REJECTION RATIO

FREQ(MHz)	50	100	200	300	400	500
dB MIN	48	42	36	33	30	28

CM TO CM REJECTION RATIO

FREQ(MHz)	50	100	200	300	400	500
dB MIN	30	27	24	22	21	20

HIPOT 2250VDC

SUPPORTED BALANCE DC LINE CURRENT TO THE CENTER TAPS
 OF TRANSFORMERS ON LINE SIDE :
 720mA MAX @57VDC CONTINUOUS
 1.2A MAX @57VDC FOR 200 MILLISECONDS

ORIGINATED BY	DATE	TITLE	PART NO. / DRAWING NO.	STANDARD DIM.	[] METRIC DIM. AS REF.	REV. : C	PAGE : 2
Alice Pang	2015-01-23	ELECTRICAL SPECIFICATION	S558-10GB-10	TOL. IN INCH	UNIT : INCH [mm]	 POWER PROTECT CONNECT	
DRAWN BY	DATE		FILE NAME	.X	SCALE : N/A		
ZC Guo	2015-01-23		S55810GB10C.DWG	.XX	SIZE : A4		
				.XXX			

THE INFORMATION CONTAINED HEREIN IS CONSIDERED "PROPRIETARY" TO BEL FUSE INC. AND SHALL NOT BE COPIED, REPRODUCED OR DISCLOSED WITHOUT THE WRITTEN APPROVAL OF BEL FUSE INC.

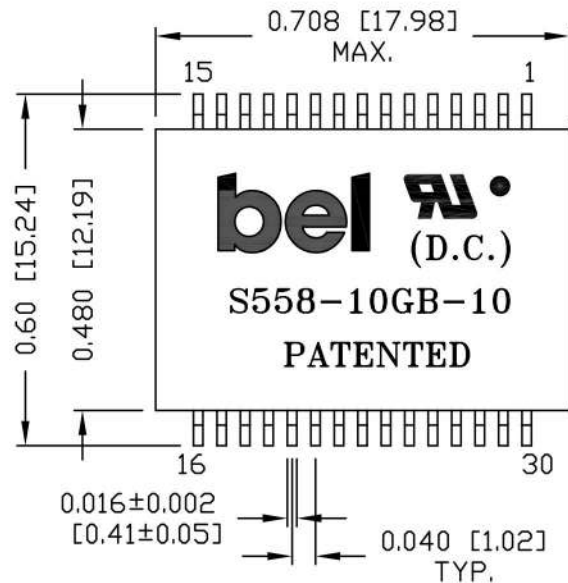

SUGGESTED PCB PAD LAYOUT

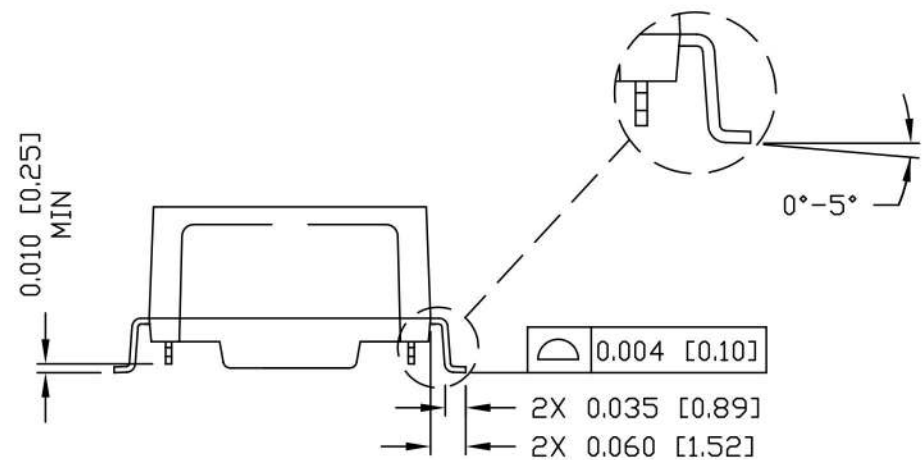
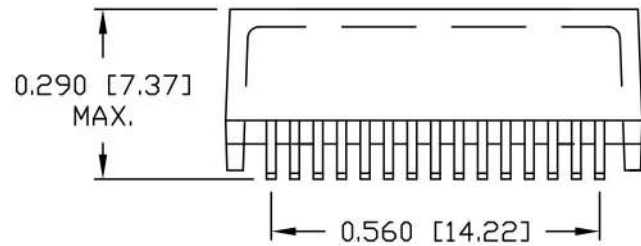
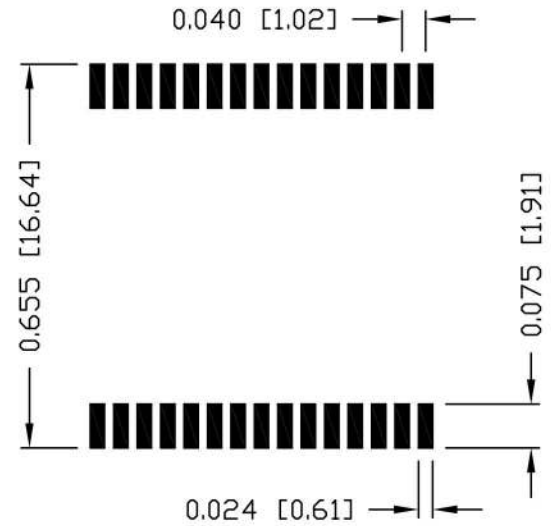

NOTES:

1. STANDARD MARKING REFER TO DOC. HAND-WORK-04.
2. PACKAGE CODE: "QACS001A".
3. PATENT NO : U.S. PAT. 7429195 ; 7924130

REV. : D	PAGE : 3
 POWER PROTECT CONNECT	

ORIGINATED BY	DATE	TITLE	PART NO. / DRAWING NO.	STANDARD DIM.	[] METRIC DIM. AS REF.
Lawrence Tsang	2016-01-25	MECHANICAL SPECIFICATION	S558-10GB-10	TOL. IN INCH	UNIT : INCH [mm]
DRAWN BY	DATE		FILE NAME	.X	SCALE : N/A
ZC Guo	2016-01-25		S55810GB10D.DWG	.XX ±0.01	SIZE : A4
				.XXX ±0.005	