

THIS DRAWING IS UNPUBLISHED. RELEASED FOR PUBLICATION
 © COPYRIGHT - By - ALL RIGHTS RESERVED.

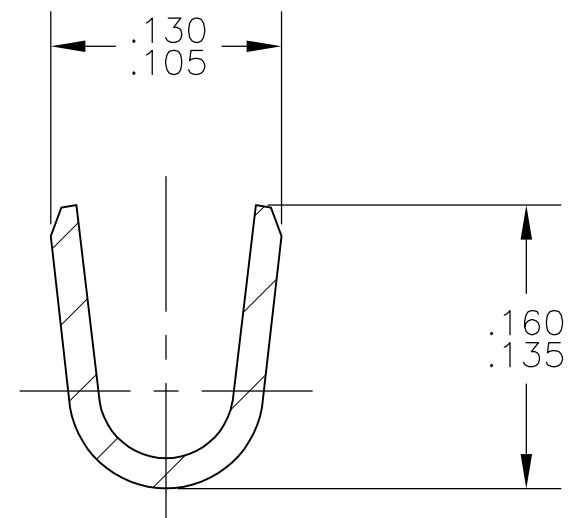
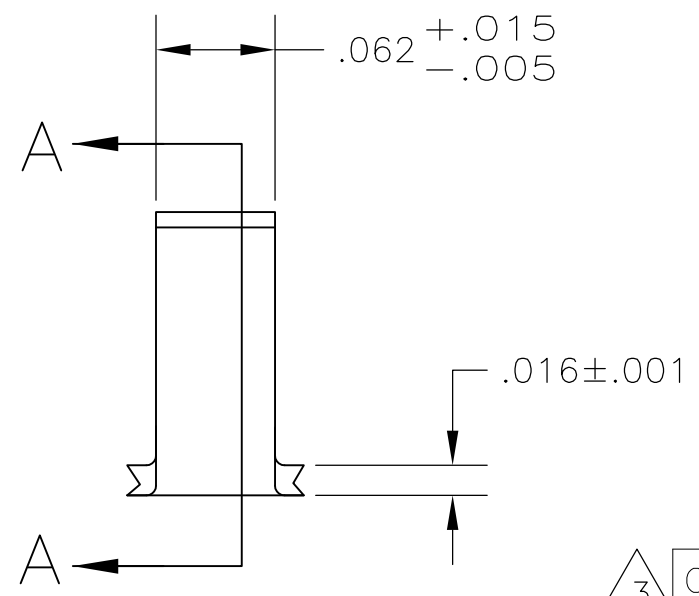
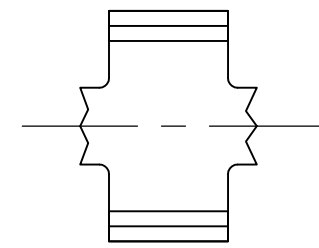

LOC	DIST	REVISIONS			
P	LTR	DESCRIPTION	DATE	DWN	APVD
AF	50	P2	REVISED PER ECO-15-012928	08SEPT15	JR MD

- SUPPLIED 50,000 PIECES PER REEL.
- WIRE RANGE IS 1400-3600 CMA
 CRIMP WIDTH: .090, F TYPE
 CRIMP HEIGHT: $\pm .002 = (\text{TOTAL CMA} + 7600) / 145,100$
 FOR APPLICATOR INFORMATION CALL: 1-800-722-1111
 FOR PRODUCT INFORMATION CALL: 1-800-522-6752

 FOREIGN PRODUCTION ONLY.



SECTION A-A

	OBSOLETE	.000150 MIN NICKEL PLATE	TEMP 3 STEEL	40862-3
	OBSOLETE	-	TEMP 3 STEEL	40862-2
	OBSOLETE	TIN	TEMP 3 STEEL	40862-1
		TIN	081 BRASS	40862
		FINISH	MATERIAL	PART NUMBER

THIS DRAWING IS A CONTROLLED DOCUMENT.		DWN MICHAEL S. FEHER 29SEP2003	 TE Connectivity															
		CHK GARY D. PORTA 29SEP2003																
DIMENSIONS: INCHES		APVD GARY D. PORTA 29SEP2003	NAME -															
TOLERANCES UNLESS OTHERWISE SPECIFIED:		PRODUCT SPEC -	APPLICATION SPEC -															
<table border="0"> <tr><td>0 PLC</td><td>± -</td></tr> <tr><td>1 PLC</td><td>± -</td></tr> <tr><td>2 PLC</td><td>± .010</td></tr> <tr><td>3 PLC</td><td>± -</td></tr> <tr><td>4 PLC</td><td>± -</td></tr> <tr><td>ANGLES</td><td>± 1°</td></tr> </table>		0 PLC	± -	1 PLC	± -	2 PLC	± .010	3 PLC	± -	4 PLC	± -	ANGLES	± 1°	114-2088	SIZE A3	CAGE CODE 00779	DRAWING NO C-40862	RESTRICTED TO -
0 PLC	± -																	
1 PLC	± -																	
2 PLC	± .010																	
3 PLC	± -																	
4 PLC	± -																	
ANGLES	± 1°																	
MATERIAL SEE TABLE	FINISH SEE TABLE	WEIGHT -	CUSTOMER DRAWING		SCALE 10:1	SHEET 1 OF 1	REV P2											