

Heating Controller

Features

- Dual Voltage (120V/240V) operations
- Auto temperature control with NTC
- NTC open protection
- Multi mode LED indicator
- Direct drive SCR
- Auto Heating off after heating timer timeout
- Low cost 8-Pin DIP and SOIC package

Applications

- Hair Curler

Description

The PT8A3230/1/2/3/4/5/6/7 is a mixed signal CMOS LSI chip designed for the automatic controller of heat with external NTC (Negative Temperature Component). NTC open protection is implemented for device safety. When NTC is open, it will cut off GATE output to disable heating, and the LED1 will flash at 1/8 CLK.

The device can be used in both 120V and 240V power line supplier, automatically adjusting the heating power according to the power line voltage to avoid heating appliance damage.

Pin Configuration

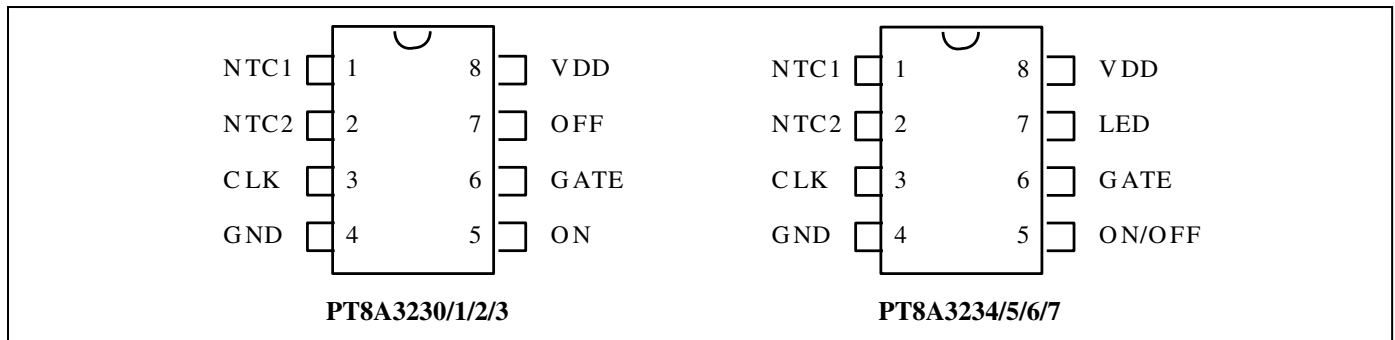

Pin Description

No.	Pin Name		I/O		Description
	PT8A3230/1/2/3	PT8A3234/5/6/7	PT8A3230/1/2/3	PT8A3234/5/6/7	
1	NTC1	NTC1	I	I	NTC voltage input, NTC open detection input.
2	NTC2	NTC2	O	O	Output signal for NTC open detection.
3	CLK	CLK	I	I	Clock input from power line.
4	GND	GND	GND	GND	Ground.
5	ON	ON/OFF	I/O	I/O	Heating-on button input for PT8A3230/1/2/3 or Heating-on/off input for PT8A3234/5/6/7 and LED driving output.
6	GATE	GATE	O	O	SCR trigger output, active high.
7	OFF	LED	I/O	O	Heating-off button input and LED2 driving output for PT8A3230/1/2/3 or only LED2 driving output for PT8A3234/5/6/7.
8	VDD	VDD	Power	Power	Power.

Maximum Ratings

Storage Temperature.....	-65°C to +150°C
Ambient Temperature with Power Applied.....	-20°C to +85°C
Supply Voltage to Ground Potential (Inputs & V _{CC} only).....	-0.5 to +6.0V
Supply Voltage to Ground Potential (Outputs & D/O only)	-0.5 to +6.0V
DC Input Voltage	-0.5V to V _{CC} +0.5V
DC Output Current	20mA
Power Dissipation.....	500mW

Note:

Stresses greater than those listed under MAXIMUM RATINGS may cause permanent damage to the device. This is a stress rating only and functional operation of the device at these or any other conditions above those indicated in the operational sections of this specification is not implied. Exposure to absolute maximum rating conditions for extended periods may affect reliability.

Recommended Operation Conditions

Sym	Pin	Description	Min	Typ	Max	Unit
V _{CC}	VDD	Supply voltage.	3.5	5.0	5.5	V
f _{CLK}	CLK	Input clock frequency	-	50/60	-	Hz
T _A	-	Operation temperature	-20	-	85	°C

DC Electrical Characteristics

(Unless otherwise noted, V_{CC} = 3.5 ~ 5V, T_A = -20 ~ 85°C)

Sym	Description	Test conditions		Min	Typ	Max	Unit
I _{IH}	Input high current	PIN: NTC1, CLK	V _{IN} = V _{CC}	-	-	5	μA
		PIN: NTC2	V _{IN} = V _{CC} Output high impedance	-	-	100	nA
I _{IL}	Input low current	PIN: NTC1, CLK	V _{IN} = GND	-	-	-5	μA
		PIN: NTC2	V _{IN} = 0 Output high impedance	-	-	-100	nA
I _{OH}	Output high current	PIN: GATE	V _{CC} = 5.0V V _{out} = 4.5V	-1.5	-	-	mA
I _{OL}	Output low current	PIN: NTC2	V _{CC} = 5.0V V _{out} = 0.5V	2.0	-	-	mA
		PIN: GATE	V _{CC} = 5.0V V _{out} = 0.5V	2.5	-	-	mA
V _{NTC0}	Input voltage 0	PIN: NTC1		0.29V _{CC}	0.31V _{CC}	0.33V _{CC}	V
V _{NTC1}	Input voltage 1	PIN: NTC1		0.37V _{CC}	0.385V _{CC}	0.40V _{CC}	
V _{NTC2}	Input voltage 2	PIN: NTC1		0.39V _{CC}	0.40V _{CC}	0.41V _{CC}	
I _{CC}	Current consumption	NTC1, CLK tied to GND, V _{CC} = 5.0V		-	-	250	μA

AC Electrical Characteristics

(Unless otherwise noted, V_{CC} = 3.5 ~ 5V, T_A = -20 ~ 85°C)

Sym	Description	Test conditions	Min	Typ	Max	Unit
f _{CLK}	CLK frequency	-	-	50/60	-	Hz
Timer	Power off timer	F _{CLK} = 50Hz	1.15	1.2	1.25	Hour

Block Diagram

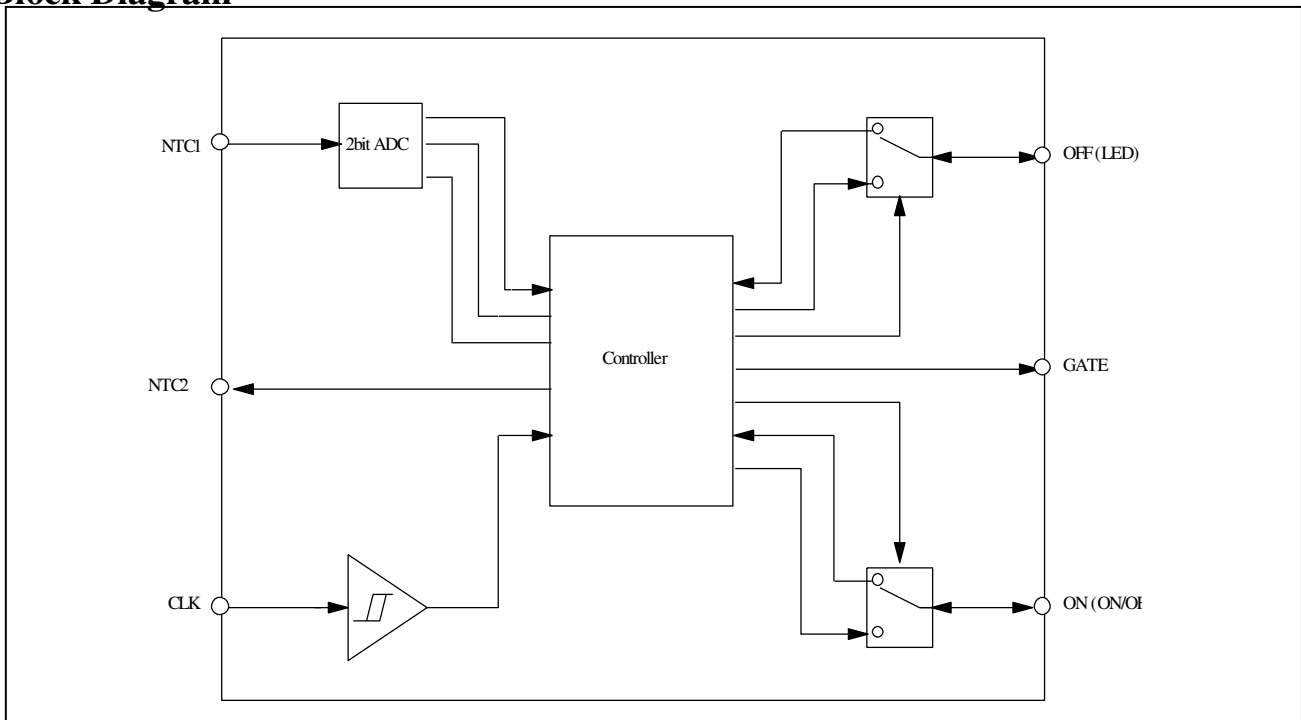

Function Description

State description

Reset: The device will be at reset state after power-on.

Heating-on: The device will be at heating-on state after heating-on button is pressed.

Heating-off: This device enters heating-off state after its power-on reset or heating timer timeout or heating-off button pressed.

Timer

Once the device enters Heating-on state, internal timer start counting. It reaches timeout state and exit heating-on state after 216000 clock period, that is, the heating time is about 1 hour for 60Hz CLK signal, and 1.2 hour for 50Hz.

Control signal output

When working in Heating-on state, GATE/LED output will be related to NTC input and CLK input amplitude.

Effect of NTC and CLK input voltage on GATE and LED indication

Working state	Power line voltage	NTC (NTC open detection)	NTC (normal temp detection)	GATE (Trigger of SCR)	LED (Pin 5)		
					PT8A3230/2/4/6		PT8A3231/3/5/7
					V _{NTC up}	V _{NTC down}	
ON	240V	NTC < 10M(Ohm)	0 ~ V _{NTC0}	25%	Flash1*	Flash1	On
			V _{NTC0} ~ V _{NTC1}	12.5%	Flash1	Flash1	On
			V _{NTC1} ~ V _{NTC2}			On	
	V _{NTC2} ~ V _{DD}		0	On	On	On	
	120V		0 ~ V _{NTC0}	100%	Flash1	Flash1	On
			V _{NTC0} ~ V _{NTC1}	50%	Flash1	Flash1	On
			V _{NTC1} ~ V _{NTC2}			On	
V _{NTC2} ~ V _{DD}		0	On	On	On		
OFF	X*		X	0	Off	Off	Off
X	X	NTC > 20M(Ohm)	X	0	Flash2*	Off	Off

*Note: 1) X means any input.

2) Flash1 frequency if 1/32 CLK.

3) Flash2 frequency is 1/8 CLK.

4) LED2(Pin 7) is always in reverse with LED1.

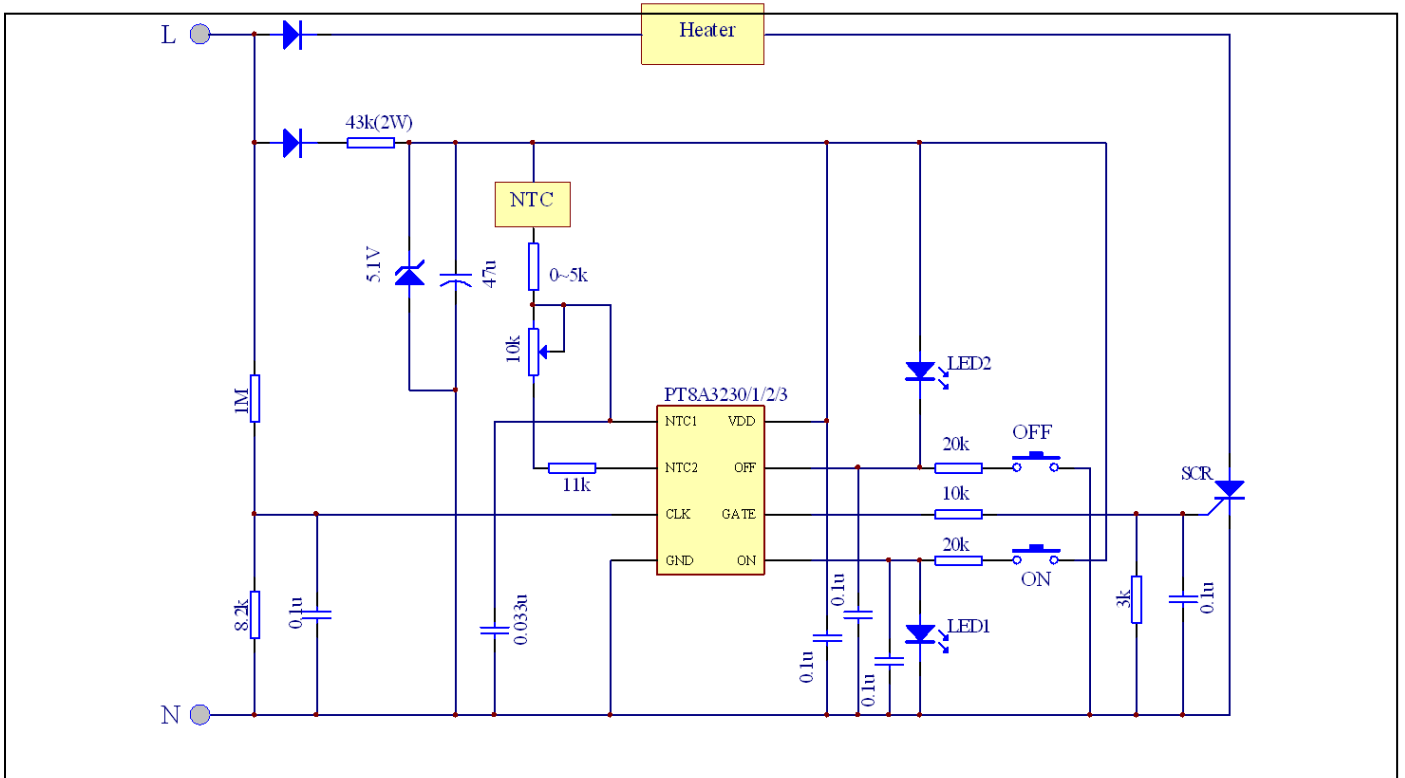
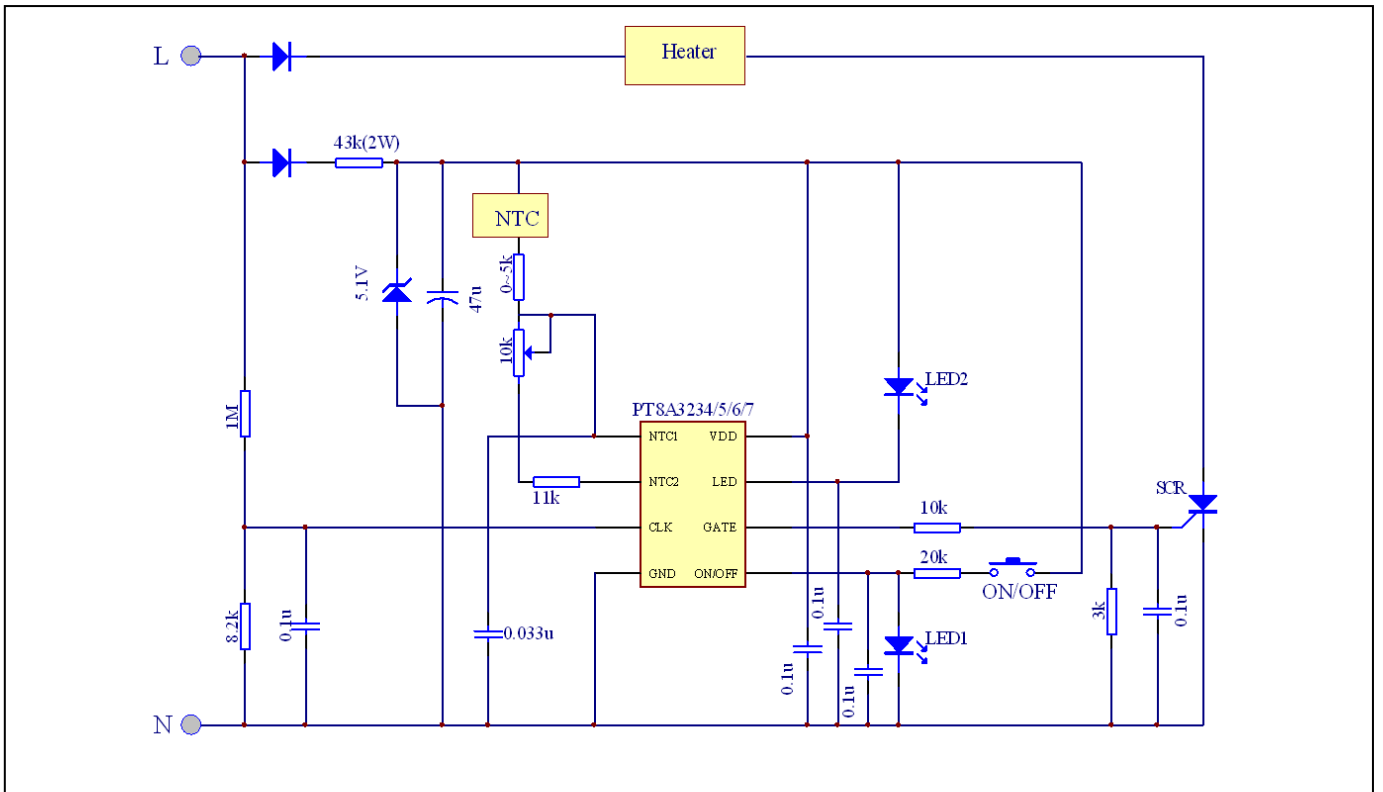
Typical Application Circuit
PT8A3230/1/2/3 application circuit

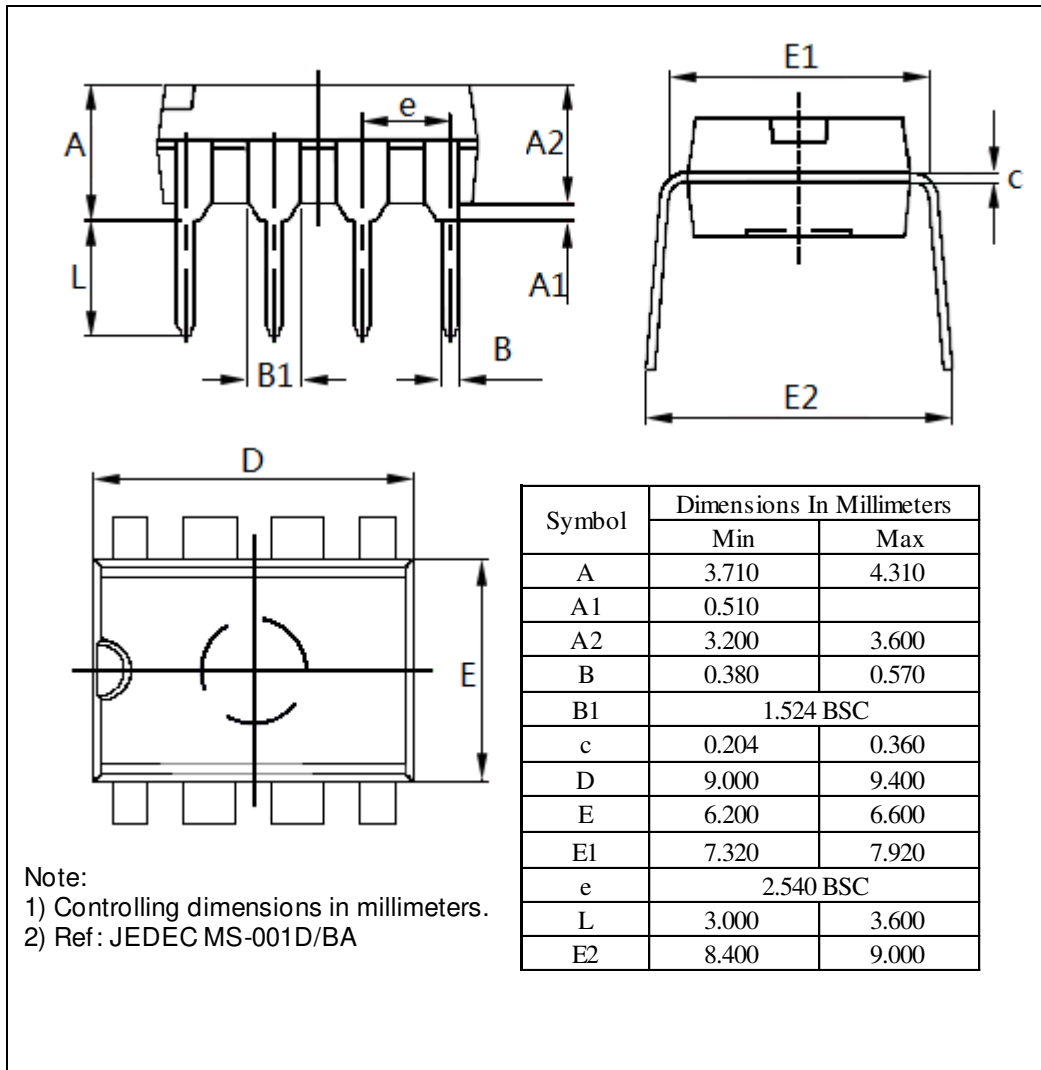
PT8A3234/5/6/7 application circuit

Mechanical Information
PE (DIP-8)

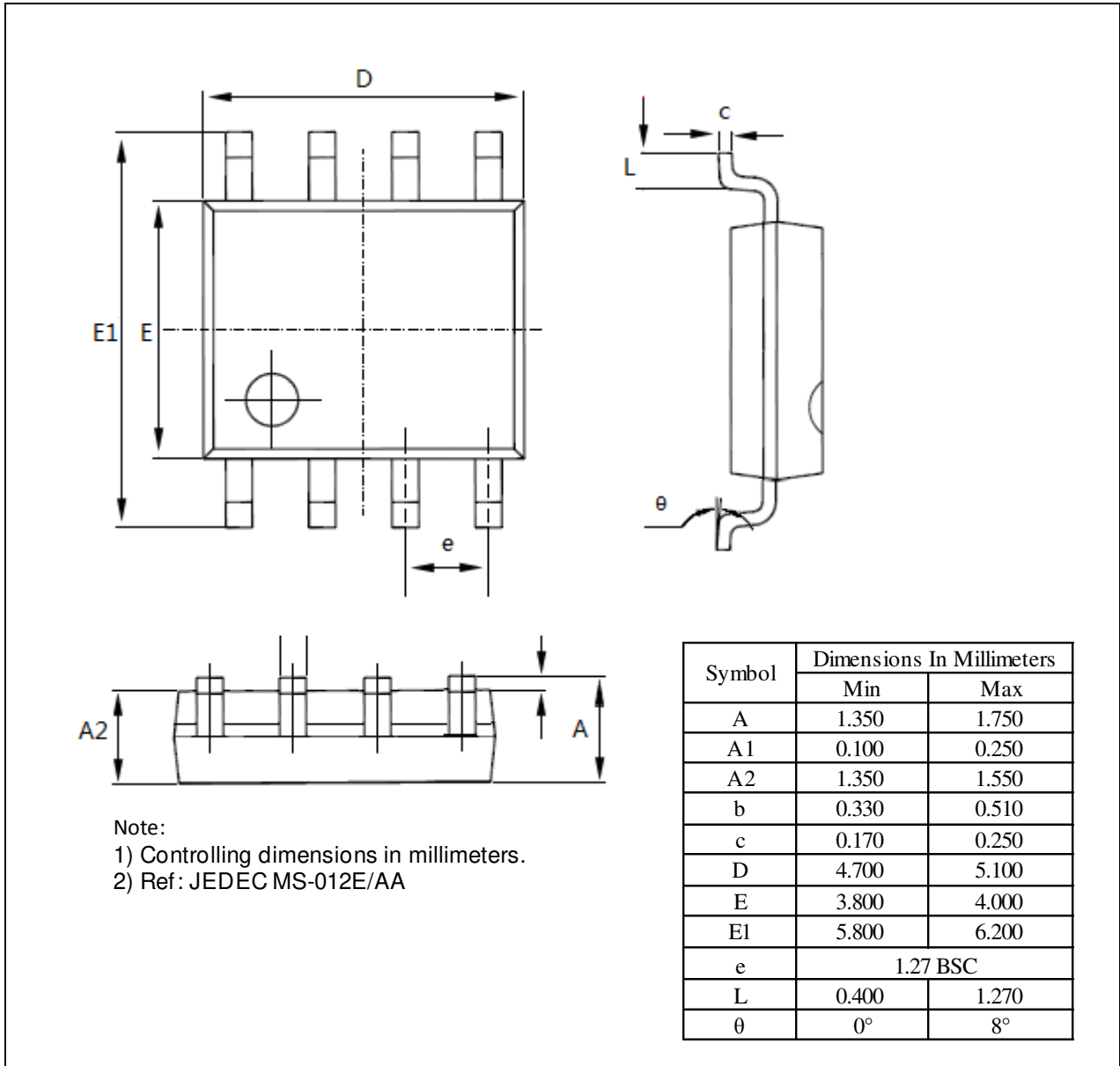
WE (SOIC-8)



Ordering Information

Part No.	Package Code	Package
PT8A323xPE	P	Lead free DIP-8
PT8A323xWE	W	Lead free and Green SOIC-8

Note:

- x=0/1/2/3/4/5/6/7 show different part no with different function, details see below table.
- E = Pb-free or Pb-free & Green
- Adding X Suffix= Tape/Reel

Part No Option

Part No.	LED@ Heating on	Timer of Auto power off (1h@60Hz)	Control Keys
PT8A3230	Flash	Y	Two Keys
PT8A3231	Constant	Y	Two Keys
PT8A3232	Flash	N	Two Keys
PT8A3233	Constant	N	Two Keys
PT8A3234	Flash	Y	Single Key
PT8A3235	Constant	Y	Single Key
PT8A3236	Flash	N	Single Key
PT8A3237	Constant	N	Single Key

Pericom Semiconductor Corporation • 1-800-435-2336 • www.pericom.com

Pericom Technology Incorporation reserves the right to make changes to its products or specifications at any time, without notice, in order to improve design or performance and to supply the best possible product. Pericom Technology does not assume any responsibility for use of any circuitry described other than the circuitry embodied in Pericom Technology product. The company makes no representations that circuitry described herein is free from patent infringement or other rights, of Pericom.