

Features

- Floating channel designed for bootstrap operation
- Fully operational to +600 V
- Tolerant to negative transient voltage – dV/dt immune
- Gate drive supply range from 10 V to 20 V
- Undervoltage lockout for all channels
- Over-current shutdown turns off all six drivers
- Independent half-bridge drivers
- Matched propagation delay for all channels
- 3.3 V logic compatible
- Outputs out of phase with inputs
- Cross-conduction prevention logic
- Integrated Operational Amplifier
- RoHS Compliant
- Automotive qualified*

Typical Applications

- Automotive Body electronics
- 3 phase motor control
- Pumps and fans

Product Summary

V_{OFFSET}	$\leq 600\text{V}$
V_{OUT}	10 – 20V
$I_{\text{O+}} \& I_{\text{O-}}$ (typical)	250mA & 500mA
$t_{\text{ON}} \& t_{\text{OFF}}$ (typical)	540ns
Deadtime (typical)	850ns

Package Options



44-Lead PLCC w/o 12 Leads

Typical Connection Diagram

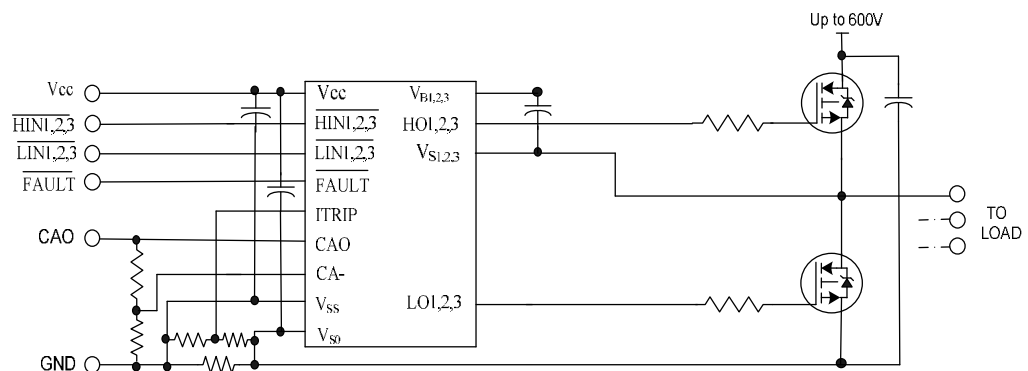

(Refer to Lead Assignments for correct pin configuration). This/These diagram(s) show electrical connections only. Please refer to our Application Notes and Design Tips for proper circuit board layout.

Table of Contents	Page
Description	3
Qualification Information	4
Absolute Maximum Ratings	5
Recommended Operating Conditions	6
Dynamic Electrical Characteristics	6
Static Electrical Characteristics	7 - 8
Functional Block Diagram	8
Input/Output Pin Equivalent Circuit Diagram	9
Lead Definitions	10
Lead Assignments	10
Application Information and Additional Details	11 - 25
Parameter Temperature Trends	26 - 29
Package Details	30 - 31
Part Marking Information	32
Ordering Information	32
Important Notice	33

Description

The AUIRS2332J is a high voltage, high speed power MOSFET and IGBT driver with three independent high and low side referenced output channels. Proprietary HVIC technology enables ruggedized monolithic construction. Logic inputs are compatible with CMOS or LSTTL outputs, down to 3.3V logic. A ground-referenced operational amplifier provides analog feedback of bridge current via an external current sense resistor. A current trip function which terminates all six outputs is also derived from this resistor. An open drain FAULT signal indicates if an over-current or undervoltage shutdown has occurred. The output drivers feature a high pulse current buffer stage designed for minimum driver cross-conduction. Propagation delays are matched to simplify use at high frequencies. The floating channel can be used to drive N-channel power MOSFET or IGBT in the high side configuration which operates up to 600 volts.

Qualification Information[†]

Qualification Level		Automotive (per AEC-Q100 ^{††})
		Comments: This family of ICs has passed an Automotive qualification. IR's Industrial and Consumer qualification level is granted by extension of the higher Automotive level.
Moisture Sensitivity Level		MSL3 ^{†††} 245°C (per IPC/JEDEC J-STD-020)
ESD	Machine Model	Class M2 (Pass +/-200V) (per AEC-Q100-003)
	Human Body Model	Class H1C (Pass +/-1500V) (per AEC-Q100-002)
	Charged Device Model	Class C4 (+/-1000V) (per AEC-Q100-011)
IC Latch-Up Test		Class II, Level A (per AEC-Q100-004)
RoHS Compliant		Yes

† Qualification standards can be found at International Rectifier's web site <http://www.irf.com/>

†† Exceptions (if any) to AEC-Q100 requirements are noted in the qualification report.

††† Higher MSL ratings may be available for the specific package types listed here. Please contact your International Rectifier sales representative for further information.

Absolute Maximum Ratings

Absolute maximum ratings indicate sustained limits beyond which permanent damage to the device may occur. These are stress ratings only, functional operation of the device at these or any other condition beyond those indicated in the “Recommended Operating Condition” is not implied. Exposure to absolute maximum-rated conditions for extended periods may affect device reliability. All voltage parameters are absolute voltages referenced to V_{SO} unless otherwise stated in the table. The thermal resistance and power dissipation ratings are measured under board mounted and still air conditions.

Symbol	Definition	Min.	Max.	Units	
$V_{B1,2,3}$	High Side Floating Supply Voltage	-0.3	620	V	
$V_{S1,2,3}$	High Side Floating Offset Voltage	$V_{B1,2,3} - 20$	$V_{B1,2,3} + 0.3$		
$V_{HO1,2,3}$	High Side Floating Output Voltage	$V_{S1,2,3} - 0.3$	$V_{B1,2,3} + 0.3$		
V_{CC}	Low Side and Logic Fixed Supply Voltage	-0.3	20		
V_{SS}	Logic Ground	$V_{CC} - 20$	$V_{CC} + 0.3$		
$V_{LO1,2,3}$	Low Side Output Voltage	-0.3	$V_{CC} + 0.3$		
V_{IN}	Logic Input Voltage ($\overline{HIN1,2,3}$, $\overline{LIN1,2,3}$ & ITRIP)	$V_{SS} - 0.3$	($V_{SS} + 15$) or ($V_{CC} + 0.3$) Whichever is lower		
V_{FLT}	FAULT Output Voltage	$V_{SS} - 0.3$	$V_{CC} + 0.3$		
V_{CAO}	Operational Amplifier Output Voltage	$V_{SS} - 0.3$	$V_{CC} + 0.3$		
V_{CA-}	Operational Amplifier Inverting Input Voltage	$V_{SS} - 0.3$	$V_{CC} + 0.3$		
dV_S/dt	Allowable Offset Supply Voltage Transient	—	50		V/ns
P_D	Package Power Dissipation @ $T_A \leq +25\text{ }^\circ\text{C}$	—	2.0		W
R_{thJA}	Thermal Resistance, Junction to Ambient	—	63		$^\circ\text{C/W}$
R_{thJC}	Thermal Resistance, Junction to Case	---	21.95	$^\circ\text{C/W}$	
T_J	Junction Temperature	—	150	$^\circ\text{C}$	
T_S	Storage Temperature	-55	150		
T_L	Lead Temperature (soldering, 10 seconds)	—	300		

Recommended Operating Conditions

The Input/Output logic timing diagram is shown in figure 1. For proper operation the device should be used within the recommended conditions. All voltage parameters are absolute voltage referenced to V_{SO} . The V_S offset rating is tested with all supplies biased at 15V differential.

Symbol	Definition	Min.	Max.	Units
$V_{B1,2,3}$	High Side Floating Supply Voltage	$V_{S1,2,3} + 10$	$V_{S1,2,3} + 20$	V
$V_{S1,2,3}$	Static High side floating offset voltage	$V_{SO} - 8$ (Note1)	600	
$V_{SH1,2,3}$	Transient High side floating offset voltage	-50 (Note2)	600	
$V_{HO1,2,3}$	High Side Floating Output Voltage	$V_{S1,2,3}$	$V_{B1,2,3}$	
V_{CC}	Low Side and Logic Fixed Supply Voltage	10	20	
V_{SS}	Logic Ground	-5	5	
$V_{LO1,2,3}$	Low Side Output Voltage	0	V_{CC}	
V_{IN}	Logic Input Voltage (HIN1,2,3, LIN1,2,3 & ITRIP)	V_{SS}	$V_{SS} + 5$	
V_{FLT}	FAULT Output Voltage	V_{SS}	V_{CC}	
V_{CAO}	Operational Amplifier Output Voltage	V_{SS}	$V_{SS} + 5$	
V_{CA-}	Operational Amplifier Inverting Input Voltage	V_{SS}	$V_{SS} + 5$	
T_A	Ambient temperature	-40	125	

Note 1: Logic operational for V_S of ($V_{SO} - 8$ V) to ($V_{SO} + 600$ V). Logic state held for V_S of ($V_{SO} - 8$ V) to ($V_{SO} - V_{BS}$).

Note 2: Operational for transient negative V_S of $V_{SS} - 50$ V with a 50 ns pulse width. Guaranteed by design. Refer to the Application Information section of this datasheet for more details.

Note 3: CAO input pin is internally clamped with a 5.2 V zener diode.

Dynamic Electrical Characteristics

Unless otherwise noted, these specifications apply for an operating junction temperature range of $-40^{\circ}\text{C} \leq T_J \leq 125^{\circ}\text{C}$ with bias conditions V_{BIAS} ($V_{CC}, V_{BS1,2,3}$) = 15 V, $C_L = 1000$ pF.

Symbol	Definition	Min	Typ	Max	Units	Test Conditions	
t_{on}	Turn-on propagation delay	400	540	700	ns	$V_{S1,2,3} = 0$ V to 600 V	
t_{off}	Turn-off propagation delay	400	540	700			
t_r	Turn-on rise time	—	80	145			
t_f	Turn-off fall time	—	40	55		V _{S1,2,3} = 0 V	
t_{trip}	ITRIP to Output Shutdown Propagation delay	400	625	920			
t_{bl}	ITRIP Blanking Time	—	400	—			
t_{flt}	ITRIP to FAULT Indication Delay	350	550	870			
$t_{flt, in}$	Input Filter Time (All Six Inputs)	—	325	—			
$t_{flt, clr}$	LIN1,2,3 to FAULT Clear Time	5300	8500	13700			
DT	Deadtime:	500	850	1100			$V_{IN} = 0$ V & 5 V without external deadtime
MDT	Deadtime matching:	—	—	145			
MT	Delay matching time (t_{ON} , t_{OFF})	—	—	50			$V_{IN} = 0$ V & 5 V without external deadtime larger than DT
PM	Pulse width distortion	—	—	75			
SR+	Operational Amplifier Slew Rate (+)	5	10	—	V/ μ s	1 V input step	
SR-	Operational Amplifier Slew Rate (-)	2.4	3.2	—		1 V input step	

NOTE: For high side PWM, HIN pulse width must be $\geq 1.5 \mu\text{sec}$

Static Electrical Characteristics

Unless otherwise noted, these specifications apply for an operating junction temperature range of $-40^{\circ}\text{C} \leq T_j \leq 125^{\circ}\text{C}$ with bias conditions of $V_{\text{BIAS}} (V_{\text{CC}}, V_{\text{BS}1,2,3}) = 15 \text{ V}$, $V_{\text{SO}1,2,3} = V_{\text{SS}}$. The V_{IN} , V_{TH} and I_{IN} parameters are referenced to V_{SS} and are applicable to all six logic input leads: HIN1,2,3 & LIN1,2,3. The V_{O} and I_{O} parameters are referenced to $V_{\text{SO}1,2,3}$ and are applicable to the respective output leads: HO1,2,3 or LO1,2,3.

Symbol	Definition	Min	Typ	Max	Units	Test Conditions
V_{IH}	Logic "0" input Voltage (OUT = LO)	—	—	2.2	V	
V_{IL}	Logic "1" input Voltage (OUT = HI)	0.8	—	—		
$V_{\text{IT,TH+}}$	ITRIP Input Positive Going Threshold	400	490	580	mV	
V_{OH}	High Level Output Voltage, $V_{\text{BIAS}} - V_{\text{O}}$	—	—	1150		
V_{OL}	Low Level Output Voltage, V_{O}	—	—	400		$V_{\text{IN}} = 0 \text{ V}$, $I_{\text{O}} = 20 \text{ mA}$
I_{LK}	Offset Supply Leakage Current	—	—	50	μA	$V_{\text{B}} = V_{\text{S}} = 600 \text{ V}$
I_{QBS}	Quiescent V_{BS} Supply Current	—	37	50		$V_{\text{IN}} = 0 \text{ V}$ or 4 V
I_{QCC}	Quiescent V_{CC} Supply Current	—	4.5	6.2	mA	$V_{\text{IN}} = 0 \text{ V}$
$I_{\text{IN+}}$	Logic "1" Input Bias Current (OUT = HI)	-450	-300	-100	μA	$V_{\text{IN}} = 0 \text{ V}$
$I_{\text{IN-}}$	Logic "0" Input Bias Current (OUT = LO)	-350	-220	-100		$V_{\text{IN}} = 4 \text{ V}$
$I_{\text{ITRIP+}}$	"High" ITRIP Bias Current	—	5	10		ITRIP = 4 V
$I_{\text{ITRIP-}}$	"LOW" ITRIP Bias Current	—	—	30		ITRIP = 0 V
$V_{\text{BSUV+}}$	V_{BS} Supply Undervoltage Positive Going Threshold	7.5	8.3	9.2	V	
$V_{\text{BSUV-}}$	V_{BS} Supply Undervoltage Negative Going Threshold	7.1	7.9	8.8		
$V_{\text{CCUV+}}$	V_{CC} Supply Undervoltage Positive going Threshold	8.3	8.9	9.7		
$V_{\text{CCUV-}}$	V_{CC} Supply Undervoltage Negative Going Threshold	8	8.6	9.4		
V_{CCUVH}	Hysteresis	—	0.3	—		
V_{BSUVH}	Hysteresis	—	0.4	—		
$R_{\text{on,FLT}}$	FAULT Low On-Resistance	—	55	75	Ω	
$I_{\text{O+}}$	Output High Short Circuit Pulsed Current	—	-250	-180	mA	$V_{\text{O}} = 0 \text{ V}$, $V_{\text{IN}} = 0 \text{ V}$ $\text{PW} \leq 10 \mu\text{s}$
$I_{\text{O-}}$	Output Low Short Circuit Pulsed Current	375	500	—		$V_{\text{O}} = 15 \text{ V}$, $V_{\text{IN}} = 5 \text{ V}$ $\text{PW} \leq 10 \mu\text{s}$
V_{OS}	Operational Amplifier Input Offset Voltage	—	—	20	mV	$V_{\text{SO}} = 0.2 \text{ V}$
$I_{\text{CA-}}$	CA- Input Bias Current	—	—	100	nA	$V_{\text{CA-}} = 1 \text{ V}$
CMRR	Operational Amplifier Common Mode Rejection Ratio	—	80	—	dB	$V_{\text{SO}} = 0.1 \text{ V}$ & 5 V
PSRR	Operational Amplifier Power Supply Rejection Ratio	—	75	—		$V_{\text{SO}} = 0.2 \text{ V}$ $V_{\text{CC}} = 9.7 \text{ V}$ & 20 V
$V_{\text{OH,AMP}}$	Operational Amplifier High Level Output Voltage	4.8	5.2	5.6	V	$V_{\text{CA-}} = 0 \text{ V}$, $V_{\text{SO}} = 1 \text{ V}$
$V_{\text{OL,AMP}}$	Operational Amplifier Low Level Output Voltage	—	—	40	mV	$V_{\text{CA-}} = 1 \text{ V}$, $V_{\text{SO}} = 0 \text{ V}$
$I_{\text{SRC,AMP}}$	Operational Amplifier Output Source Current	—	-7	-4	mA	$V_{\text{CA-}} = 0 \text{ V}$, $V_{\text{SO}} = 1 \text{ V}$ $V_{\text{CAO}} = 4 \text{ V}$
$I_{\text{SNK,AMP}}$	Operational Amplifier Output Sink Current	1	2.1	—		$V_{\text{CA-}} = 1 \text{ V}$, $V_{\text{SO}} = 0 \text{ V}$ $V_{\text{CAO}} = 2 \text{ V}$

$I_{O+,AMP}$	Operational Amplifier Output High Short Circuit Current	-30	-10	—	$V_{CA-} = 0\text{ V}, V_{SO} = 5\text{ V}$ $V_{CAO} = 0\text{ V}$
$I_{O-,AMP}$	Operational Amplifier Output Low Short Circuit Current	—	4	—	$V_{CA-} = 5\text{ V}, V_{SO} = 0\text{ V}$ $V_{CAO} = 5\text{ V}$

Functional Block Diagram

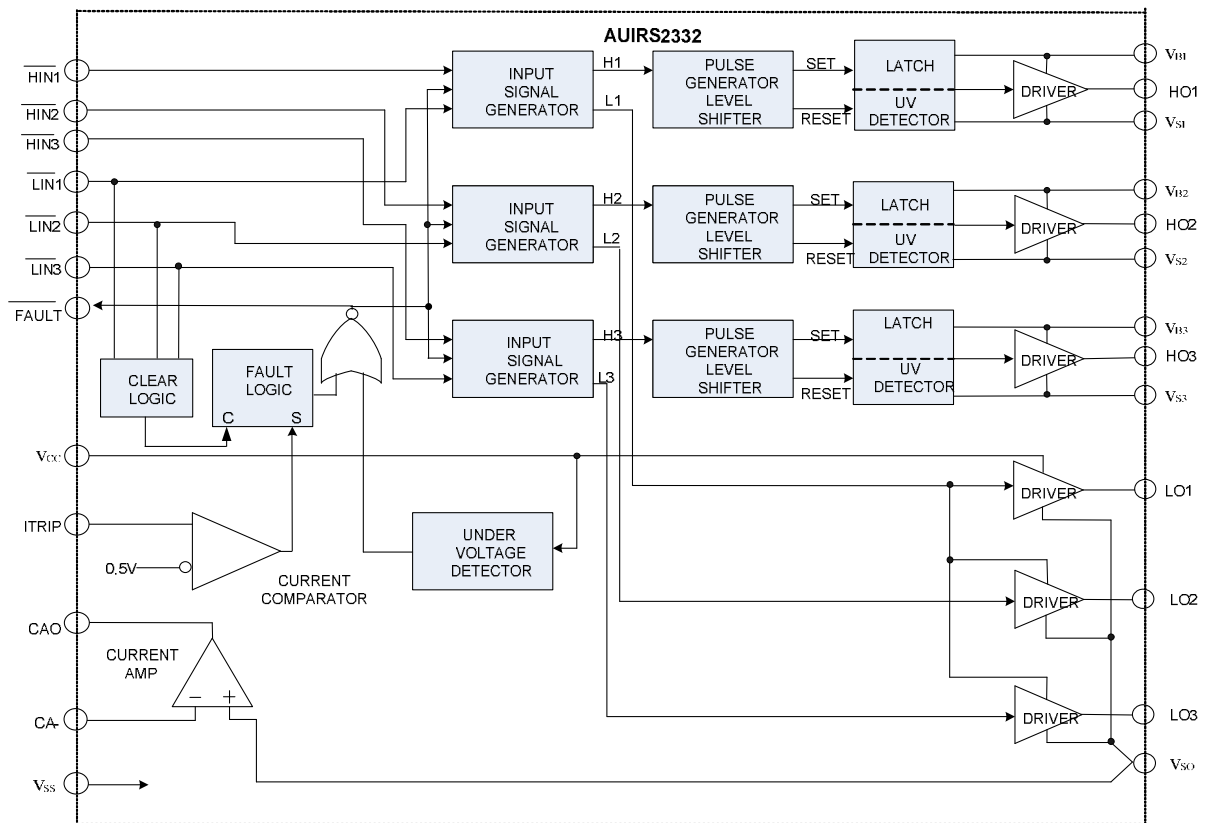

Input/Output Pin Equivalent Circuit Diagram:

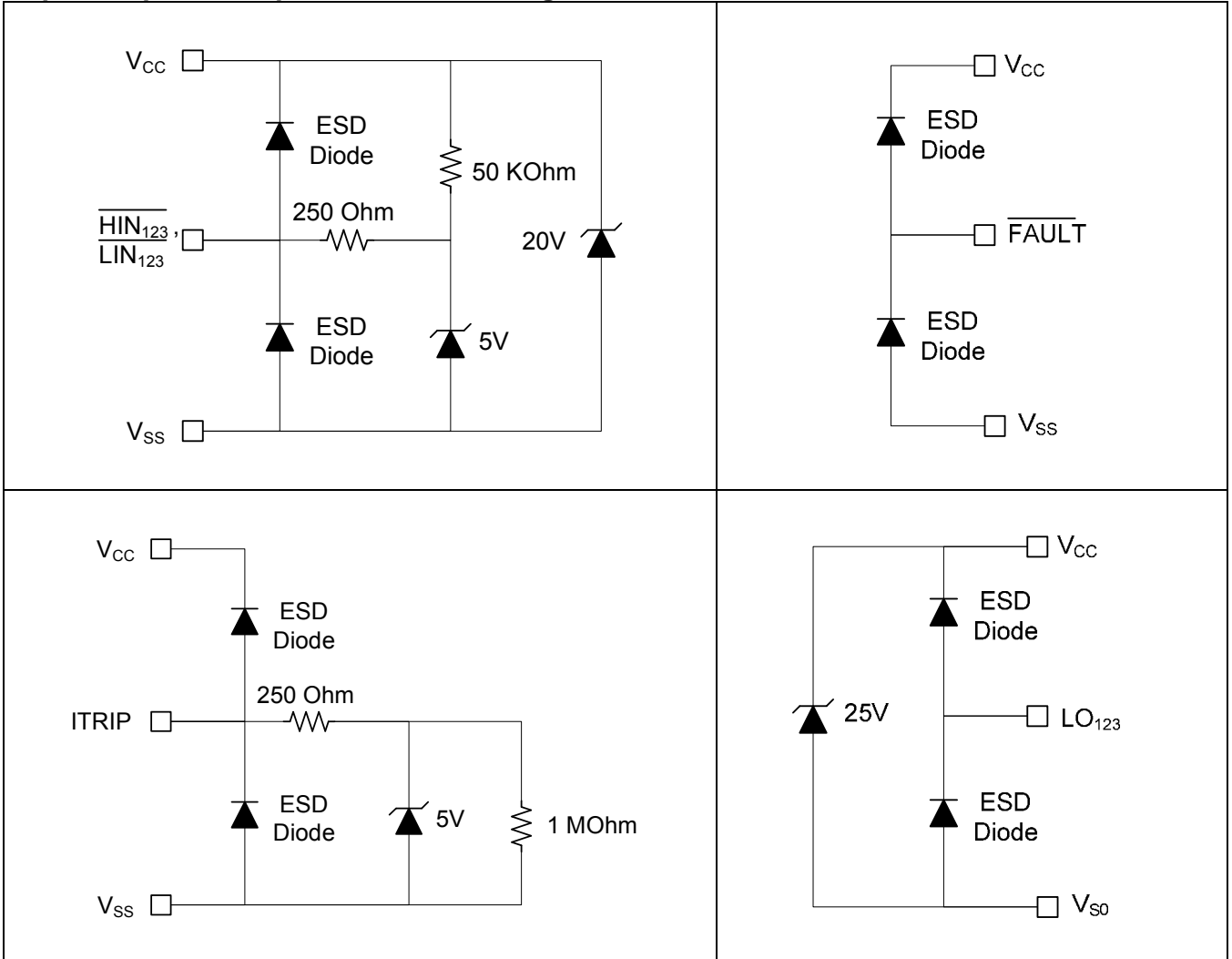

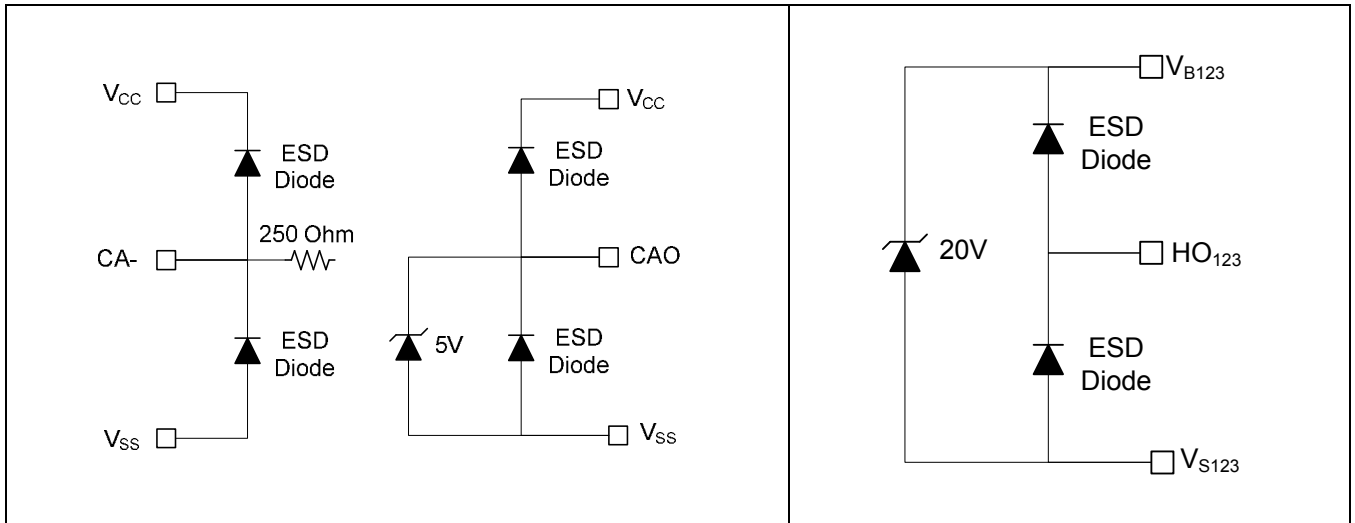

Lead Definitions

Symbol	Description
HIN1,2,3	Logic input for high side gate driver outputs (HO1,2,3), out of phase
LIN1,2,3	Logic input for low side gate driver output (LO1,2,3), out of phase
FAULT	Indicates over-current or undervoltage lockout (low side) has occurred, negative logic
V _{CC}	Low side and logic fixed supply
ITRIP	Input for over-current shutdown
CAO	Output of current amplifier
CA-	Negative input of current amplifier
V _{SS}	Logic Ground
V _{B1,2,3}	High side floating supply
HO1,2,3	High side gate drive output
V _{S1,2,3}	High side floating supply return
LO1,2,3	Low side gate drive output
V _{SO}	Low side return and positive input of current amplifier

#Leas7, #11, #13, #15, #17, #20, #21 are N.C.

Lead Assignments

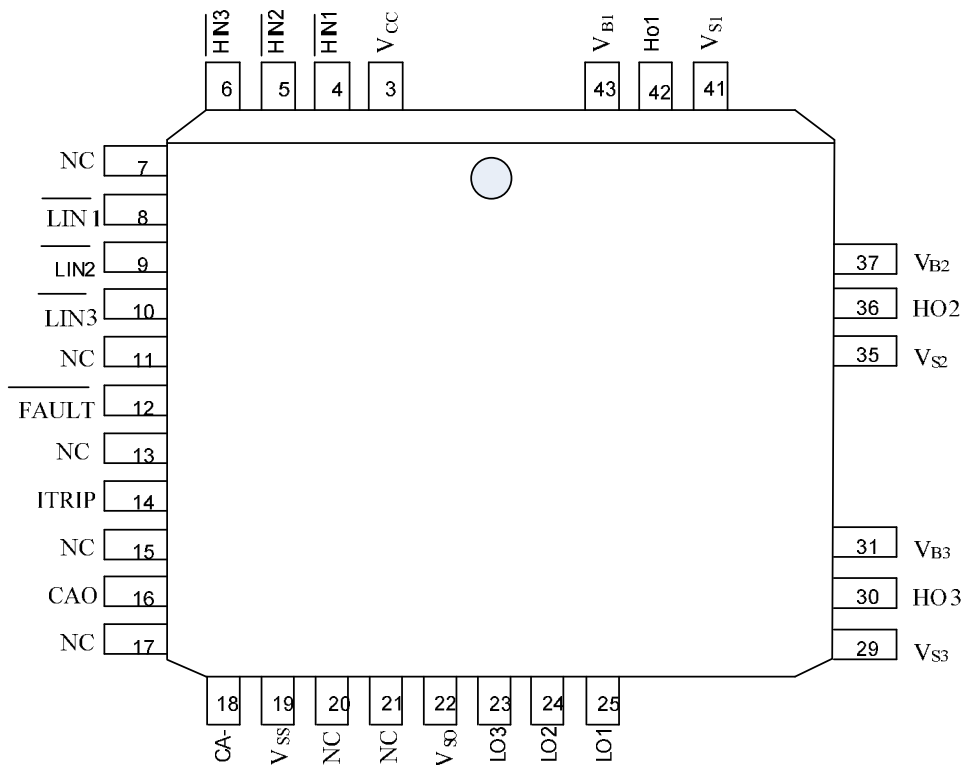

Leads num. 7, 11, 13, 15, 17, 20 and 21 are N.C.

Application Information and Additional Details

Information regarding the following topics are included as subsections within this section of the datasheet.

- IGBT/MOSFET Gate Drive
- Switching and Timing Relationships
- Deadtime
- Matched Propagation Delays
- Input Logic Compatibility
- Undervoltage Lockout Protection
- Shoot-Through Protection
- Fault Reporting
- Over-Current Protection
- Over-Temperature Shutdown Protection
- Truth Table: Undervoltage lockout, ITRIP
- Advanced Input Filter
- Short-Pulse / Noise Rejection
- Integrated Bootstrap Functionality
- Bootstrap Power Supply Design
- Separate Logic and Power Grounds
- Negative V_S Transient SOA
- DC- bus Current Sensing
- PCB Layout Tips
- Additional Documentation

IGBT/MOSFET Gate Drive

The AUIRS2332J HVIC is designed to drive up to six MOSFET or IGBT power devices. Figures 1 and 2 illustrate several parameters associated with the gate drive functionality of the HVIC. The output current of the HVIC, used to drive the gate of the power switch, is defined as I_{O+} . The voltage that drives the gate of the external power switch is defined as V_{HO} for the high-side power switch and V_{LO} for the low-side power switch; this parameter is sometimes generically called V_{OUT} and in this case does not differentiate between the high-side or low-side output voltage.

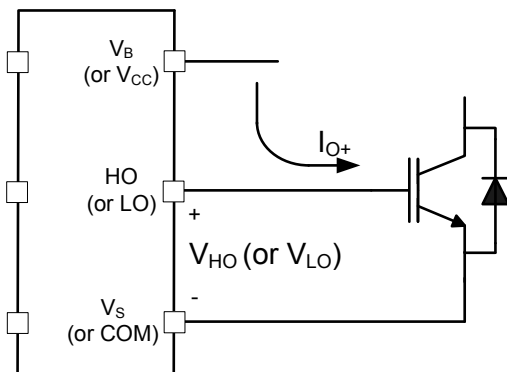

Figure 1: HVIC sourcing current

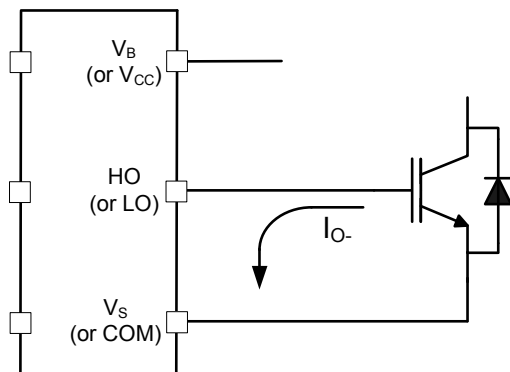

Figure 2: HVIC sinking current

Switching and Timing Relationships

The relationship between the input and output signals of the AUIRS2332J are illustrated below in Figures 3. From these figures, we can see the definitions of several timing parameters (i.e., PW_{IN} , PW_{OUT} , t_{ON} , t_{OFF} , t_R , and t_F) associated with this device.

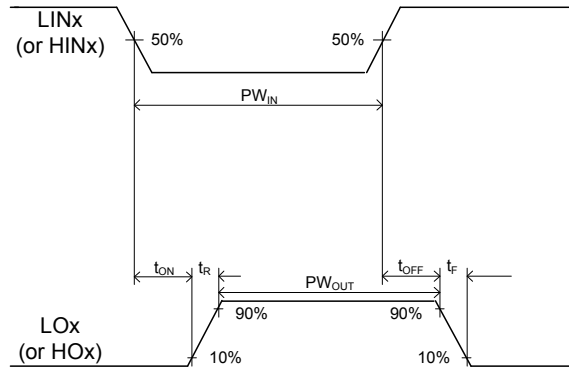

Figure 3: Switching time waveforms

The following two figures illustrate the timing relationships of some of the functionalities of the AUIRS2332J. These functionalities are described in further detail later in this document.

During interval A of Figure 4, the HVIC has received the command to turn-on both the high- and low-side switches at the same time; as a result, the shoot-through protection of the HVIC has prevented this condition and both the high- and low-side output are held in the off state.

Interval B of Figures 4 shows that the signal on the ITRIP input pin has gone from a low to a high state; as a result, all of the gate drive outputs have been disabled (i.e., see that HOx has returned to the low state; LOx is also held low) and a fault is reported by the FAULT output transitioning to the low state. Once the ITRIP input has returned to the low state, the fault condition is latched until the all LINx become high.

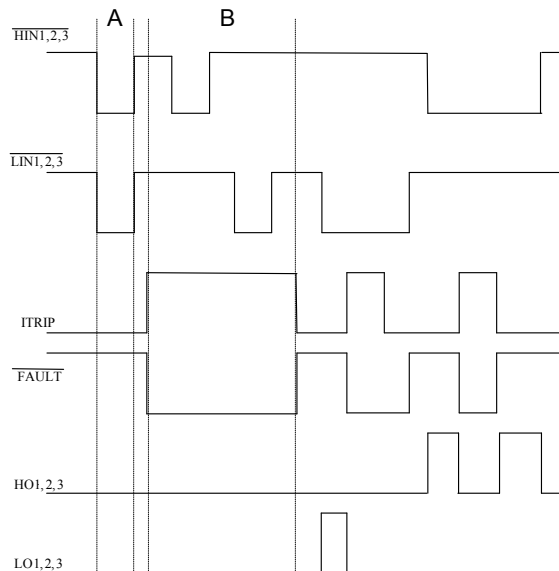

Figure 4: Input/output timing diagram

Deadtime

This HVIC features integrated deadtime protection circuitry. The deadtime for this IC is fixed; other ICs within IR's HVIC portfolio feature programmable deadtime for greater design flexibility. The deadtime feature inserts a time period (a minimum deadtime) in which both the high- and low-side power switches are held off; this is done to ensure that the power switch being turned off has fully turned off before the second power switch is turned on. This minimum deadtime is automatically inserted whenever the external deadtime is shorter than DT; external deadtimes larger than DT are not modified by the gate driver. Figure 5 illustrates the deadtime period and the relationship between the output gate signals.

The deadtime circuitry of the AUIRS2332J is matched with respect to the high- and low-side outputs of a given channel; additionally, the deadtimes of each of the three channels are matched.

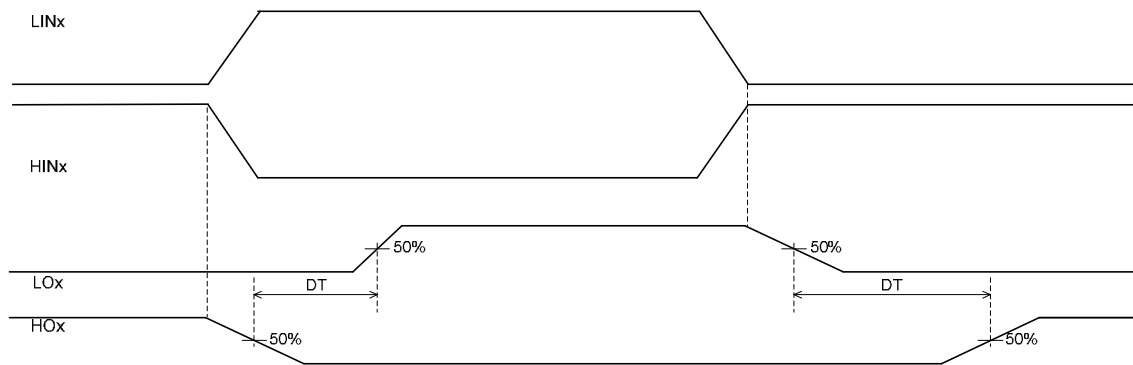

Figure 5: Illustration of deadtime

Matched Propagation Delays

The AUIRS2332J HVIC is designed with propagation delay matching circuitry. With this feature, the IC's response at the output to a signal at the input requires approximately the same time duration (i.e., t_{ON} , t_{OFF}) for both the low-side channels and the high-side channels. Additionally, the propagation delay for each low-side channel is matched when compared to the other low-side channels and the propagation delays of the high-side channels are matched with each other. The propagation turn-on delay (t_{ON}) of the AUIRS2332J is matched to the propagation turn-off delay (t_{OFF}).

Input Logic Compatibility

The inputs of this IC are compatible with standard CMOS and TTL outputs. The AUIRS2332J has been designed to be compatible with 3.3 V and 5 V logic-level signals. The AUIRS2332J features an integrated 5.2 V Zener clamp on the HIN, LIN, and ITRIP pins. Figure 6 illustrates an input signal to the AUIRS2332J, its input threshold values, and the logic state of the IC as a result of the input signal.

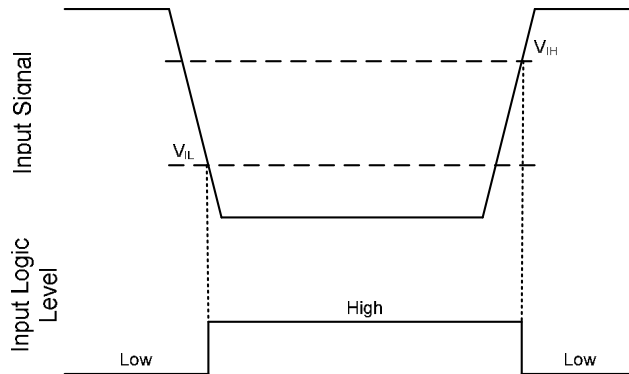

Figure 6: HIN & LIN input thresholds

Undervoltage Lockout Protection

This IC provides undervoltage lockout protection on both the V_{CC} (logic and low-side circuitry) power supply and the V_{BS} (high-side circuitry) power supply. Figure 7 is used to illustrate this concept; V_{CC} (or V_{BS}) is plotted over time and as the waveform crosses the UVLO threshold ($V_{CCUV+/-}$ or $V_{BSUV+/-}$) the undervoltage protection is enabled or disabled.

Upon power-up, should the V_{CC} voltage fail to reach the V_{CCUV+} threshold, the IC will not turn-on. Additionally, if the V_{CC} voltage decreases below the V_{CCUV-} threshold during operation, the undervoltage lockout circuitry will recognize a fault condition and shutdown the high- and low-side gate drive outputs, and the FAULT pin will transition to the low state to inform the controller of the fault condition.

Upon power-up, should the V_{BS} voltage fail to reach the V_{BSUV} threshold, the IC will not turn-on. Additionally, if the V_{BS} voltage decreases below the V_{BSUV} threshold during operation, the undervoltage lockout circuitry will recognize a fault condition, and shutdown the high-side gate drive outputs of the IC.

The UVLO protection ensures that the IC drives the external power devices only when the gate supply voltage is sufficient to fully enhance the power devices. Without this feature, the gates of the external power switch could be driven with a low voltage, resulting in the power switch conducting current while the channel impedance is high; this could result in very high conduction losses within the power device and could lead to power device failure.

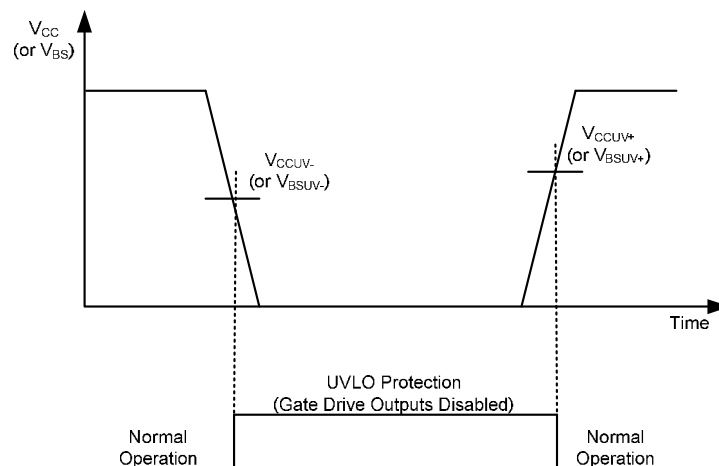

Figure 7: UVLO protection

Shoot-Through Protection

The AUIRS2332J is equipped with shoot-through protection circuitry (also known as cross-conduction prevention circuitry). Figure 8 shows how this protection circuitry prevents both the high- and low-side switches from conducting at the same time. Table 1 illustrates the input/output relationship of the devices in the form of a truth table. Note that the AUIRS2332J has inverting inputs (the output is out-of-phase with its respective input).

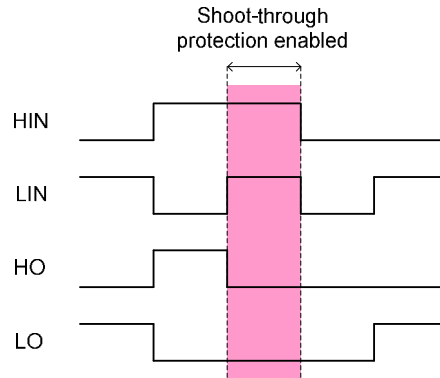

Figure 8: Illustration of shoot-through protection circuitry

AUIRS2332J			
HIN	LIN	HO	LO
0	0	0	0
0	1	1	0
1	0	0	1
1	1	0	0

Table 1: Input/output truth table

Fault Reporting

The AUIRS2332J provides an integrated fault reporting output. There are two situations that would cause the HVIC to report a fault via the FAULT pin. The first is an undervoltage condition of V_{CC} and the second is if the ITRIP pin recognizes a fault. Once the fault condition occurs, the FAULT pin is internally pulled to V_{SS} and the fault condition is latched. The fault output stays in the low state until the fault condition has been removed by all LINx set to high state. Once the fault is removed, the voltage on the FAULT pin will return to V_{CC} .

Over-Current Protection

The AUIRS2332J HVICs are equipped with an ITRIP input pin. This functionality can be used to detect over-current events in the DC- bus. Once the HVIC detects an over-current event through the ITRIP pin, the outputs are shutdown, a fault is reported through the FAULT pin.

The level of current at which the over-current protection is initiated is determined by the resistor network (i.e., R_0 , R_1 , and R_2) connected to ITRIP as shown in Figure 9, and the ITRIP threshold ($V_{IT,TH+}$). The circuit designer will need to determine the maximum allowable level of current in the DC- bus and select R_0 , R_1 , and R_2 such that the voltage at node V_X reaches the over-current threshold ($V_{IT,TH+}$) at that current level.

$$V_{IT,TH+} = R_0 I_{DC} (R_1 / (R_1 + R_2))$$

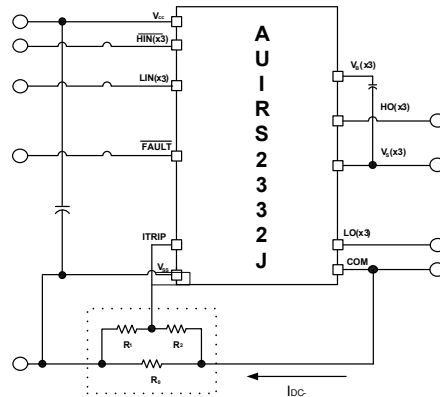

Figure 9: Programming the over-current protection

For example, a typical value for resistor R_0 could be 50 m Ω . The voltage of the ITRIP pin should not be allowed to exceed 5 V; if necessary, an external voltage clamp may be used.

Over-Temperature Shutdown Protection

The ITRIP input of the AUIRS2332J can also be used to detect over-temperature events in the system and initiate a shutdown of the HVIC (and power switches) at that time. In order to use this functionality, the circuit designer will need to design the resistor network as shown in Figure 10 and select the maximum allowable temperature.

This network consists of a thermistor and two standard resistors R_3 and R_4 . As the temperature changes, the resistance of the thermistor will change; this will result in a change of voltage at node V_X . The resistor values should be selected such the voltage V_X should reach the threshold voltage ($V_{IT,TH+}$) of the ITRIP functionality by the time that the maximum allowable temperature is reached. The voltage of the ITRIP pin should not be allowed to exceed 5 V.

When using both the over-current protection and over-temperature protection with the ITRIP input, OR-ing diodes (e.g., DL4148) can be used. This network is shown in Figure 11; the OR-ing diodes have been labeled D_1 and D_2 .

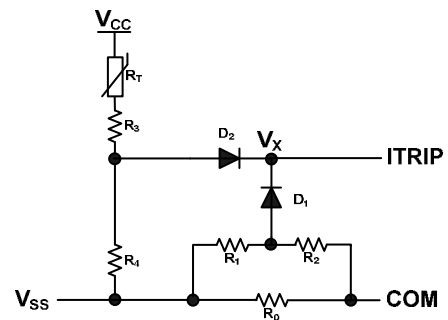
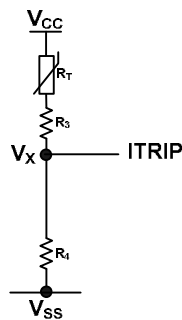

Figure 10: Programming over-temperature protection **Figure 11: Using over-current protection and over-temperature protection**

Truth Table: Undervoltage lockout and ITRIP

Table 2 provides the truth table for the AUIRS2332J. The first line shows that the UVLO for V_{CC} has been tripped; the FAULT output has gone low and the gate drive outputs have been disabled. V_{CCUV} is not latched in this case and when V_{CC} is greater than V_{CCUV} , the FAULT output returns to the high impedance state.

The second case shows that the UVLO for V_{BS} has been tripped and that the high-side gate drive outputs have been disabled. After V_{BS} exceeds the V_{BSUV} threshold, HO will stay low until the HVIC input receives a new falling transition of HIN. The third case shows the normal operation of the HVIC. The fourth case illustrates that the ITRIP trip threshold has been reached and that the gate drive outputs have been disabled and a fault has been reported through the fault pin. The fault output stays in the low state until the fault condition has been removed by all LINx set to high state. Once the fault is removed, the voltage on the FAULT pin will return to V_{CC} .

	VCC	VBS	ITRIP	FAULT	LO	HO
UVLO V_{CC}	$<V_{CCUV}$	---	---	0	0	0
UVLO V_{BS}	15 V	$<V_{BSUV}$	0 V	High impedance	LIN	0
Normal operation	15 V	15 V	0 V	High impedance	LIN	HIN
ITRIP fault	15 V	15 V	$>V_{ITRIP}$	0	0	0

Table 2: AUIRS2332J UVLO, ITRIP & FAULT truth table

Advanced Input Filter

The advanced input filter allows an improvement in the input/output pulse symmetry of the HVIC and helps to reject noise spikes and short pulses. This input filter has been applied to the HIN and LIN. The working principle of the new filter is shown in Figures 12 and 13.

Figure 12 shows a typical input filter and the asymmetry of the input and output. The upper pair of waveforms (Example 1) shows an input signal with a duration much longer than $t_{FIL,IN}$; the resulting output is approximately the difference between the input signal and $t_{FIL,IN}$. The lower pair of waveforms (Example 2) show an input signal with a duration slightly longer than $t_{FIL,IN}$; the resulting output is approximately the difference between the input signal and $t_{FIL,IN}$.

Figure 13 shows the advanced input filter and the symmetry between the input and output. The upper pair of waveforms (Example 1) show an input signal with a duration much longer than $t_{FIL,IN}$; the resulting output is approximately the same duration as the input signal. The lower pair of waveforms (Example 2) show an input signal with a duration slightly longer than $t_{FIL,IN}$; the resulting output is approximately the same duration as the input signal.

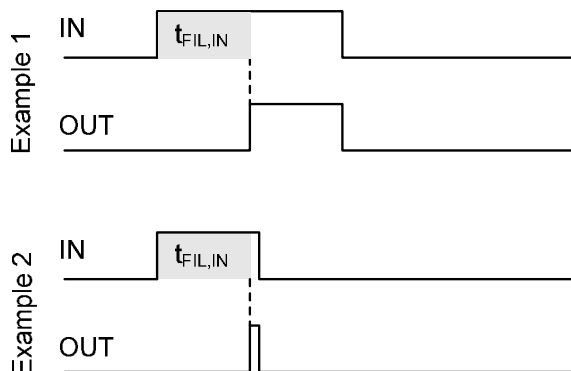

Figure 12: Typical input filter

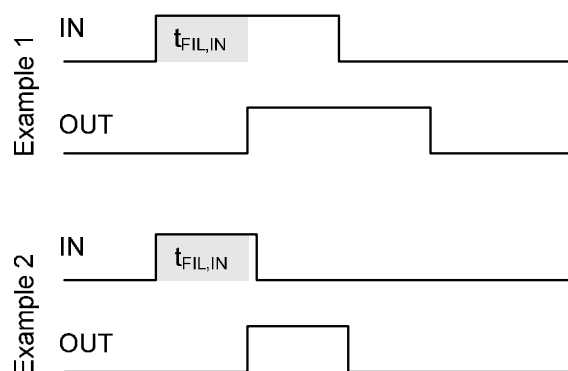

Figure 13: Advanced input filter

Short-Pulse / Noise Rejection

This device's input filter provides protection against short-pulses (e.g., noise) on the input lines. If the duration of the input signal is less than $t_{FIL,IN}$, the output will not change states. Example 1 of Figure 14 shows the input and output in the low state with positive noise spikes of durations less than $t_{FIL,IN}$; the output does not change states. Example 2 of Figure 19 shows the input and output in the high state with negative noise spikes of durations less than $t_{FIL,IN}$; the output does not change states.

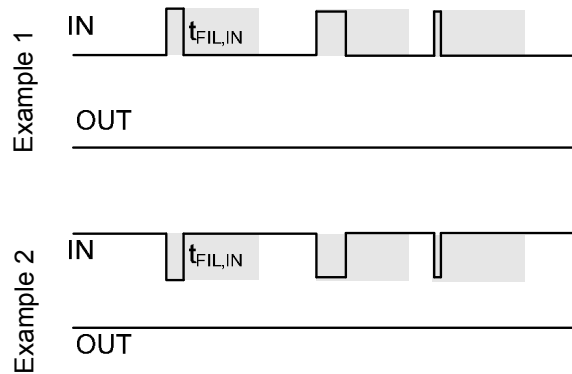

Figure 14: Noise rejecting input filters

Figures 15 and 16 present lab data that illustrates the characteristics of the input filters while receiving ON and OFF pulses.

The input filter characteristic is shown in Figure 15; the left side illustrates the narrow pulse ON (short positive pulse) characteristic while the left shows the narrow pulse OFF (short negative pulse) characteristic. The x-axis of Figure 20 shows the duration of PW_{IN} , while the y-axis shows the resulting PW_{OUT} duration. It can be seen that for a PW_{IN} duration less than $t_{FIL,IN}$, that the resulting PW_{OUT} duration is zero (e.g., the filter rejects the input signal/noise). We also see that once the PW_{IN} duration exceed $t_{FIL,IN}$, that the PW_{OUT} durations mimic the PW_{IN} durations very well over this interval with the symmetry improving as the duration increases. To ensure proper operation of the HVIC, it is suggested that the input pulse width for the high-side inputs be ≥ 500 ns.

The difference between the PW_{OUT} and PW_{IN} signals of both the narrow ON and narrow OFF cases is shown in Figure 16; the careful reader will note the scale of the y-axis. The x-axis of Figure 21 shows the duration of PW_{IN} , while the y-axis shows the resulting $PW_{OUT}-PW_{IN}$ duration. This data illustrates the performance and near symmetry of this input filter.

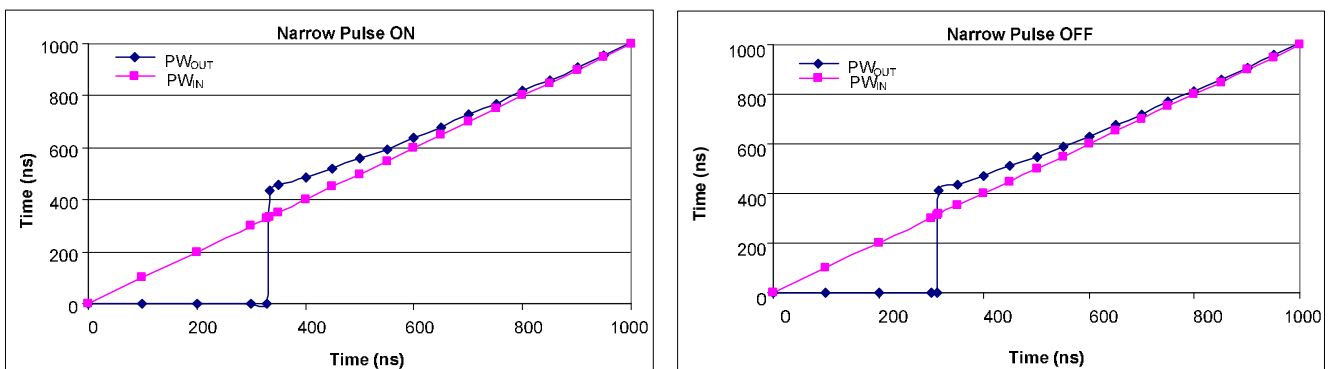

Figure 15: AUIRS2332J input filter characteristic

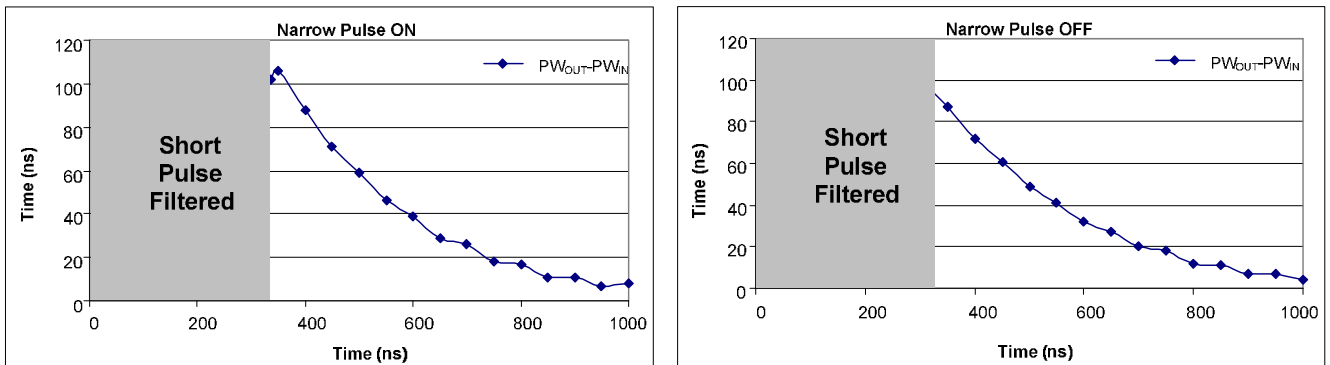

Figure 16: Difference between the input pulse and the output pulse

Separate Logic and Power Grounds

The AUIRS2332J has separate logic and power ground pin (V_{SS} and V_{SO} respectively) to eliminate some of the noise problems that can occur in power conversion applications. Current sensing shunts are commonly used in many applications for power inverter protection (i.e., over-current protection), and in the case of motor drive applications, for motor current measurements. In these situations, it is often beneficial to separate the logic and power grounds.

Figure 19 shows a HVIC with separate V_{SS} and V_{SO} pins and how these two grounds are used in the system. The V_{SS} is used as the reference point for the logic and over-current circuitry; V_X in the figure is the voltage between the ITRIP pin and the V_{SS} pin. Alternatively, the V_{SO} pin is the reference point for the low-side gate drive circuitry. The output voltage used to drive the low-side gate is $V_{LO-V_{SO}}$; the gate-emitter voltage (V_{GE}) of the low-side switch is the output voltage of the driver minus the drop across $R_{G,LO}$.

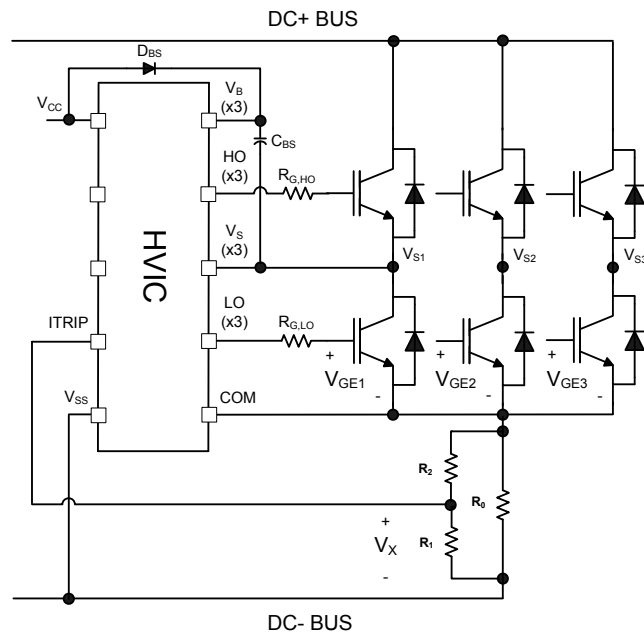

Figure 19: Separate V_{SS} and V_{SO} (COM) pins

Negative V_S Transient SOA

A common problem in today's high-power switching converters is the transient response of the switch node's voltage as the power switches transition on and off quickly while carrying a large current. A typical 3-phase inverter circuit is shown in Figure 20; here we define the power switches and diodes of the inverter.

If the high-side switch (e.g., the IGBT Q1 in Figures 21 and 22) switches off, while the U phase current is flowing to an inductive load, a current commutation occurs from high-side switch (Q1) to the diode (D2) in parallel with the low-side switch of the same inverter leg. At the same instance, the voltage node V_{S1} , swings from the positive DC bus voltage to the negative DC bus voltage.

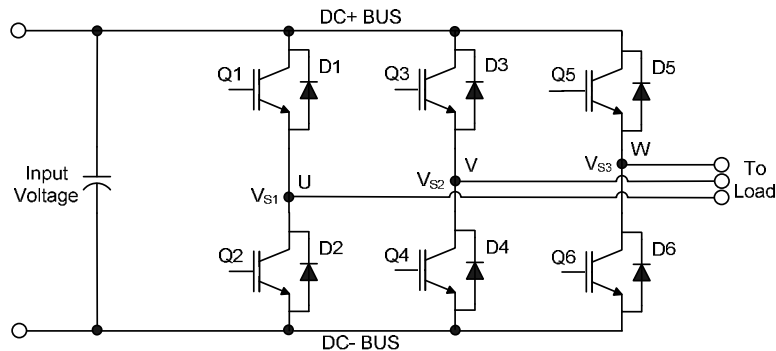

Figure 20: Three phase inverter

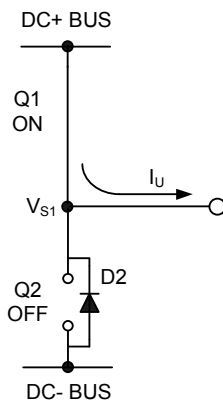

Figure 21: Q1 conducting

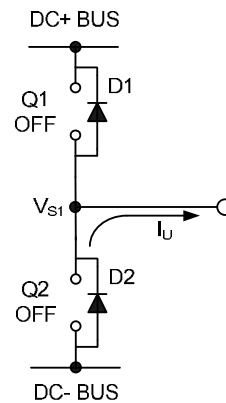

Figure 22: D2 conducting

Also when the V phase current flows from the inductive load back to the inverter (see Figures 23 and 24), and Q4 IGBT switches on, the current commutation occurs from D3 to Q4. At the same instance, the voltage node, V_{S2} , swings from the positive DC bus voltage to the negative DC bus voltage.

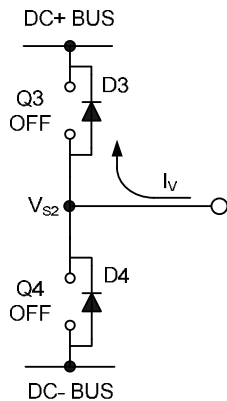

Figure 23: D3 conducting

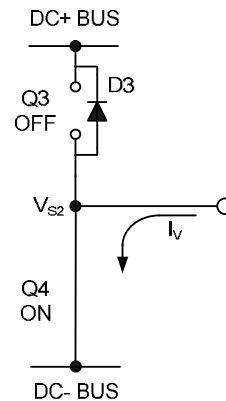

Figure 24: Q4 conducting

However, in a real inverter circuit, the V_S voltage swing does not stop at the level of the negative DC bus, rather it swings below the level of the negative DC bus. This undershoot voltage is called “negative V_S transient”.

The circuit shown in Figure 25 depicts one leg of the three phase inverter; Figures 26 and 27 show a simplified illustration of the commutation of the current between Q1 and D2. The parasitic inductances in the power circuit from the die bonding to the PCB tracks are lumped together in L_C and L_E for each IGBT. When the high-side switch is on, V_{S1} is below the DC+ voltage by the voltage drops associated with the power switch and the parasitic elements of the circuit. When the high-side power switch turns off, the load current momentarily flows in the low-side freewheeling diode due to the inductive load connected to V_{S1} (the load is not shown in these figures). This current flows from the DC- bus (which is connected to the VSO pin of the HVIC) to the load and a negative voltage between V_{S1} and the DC- Bus is induced (i.e., the VSO pin of the HVIC is at a higher potential than the V_S pin).

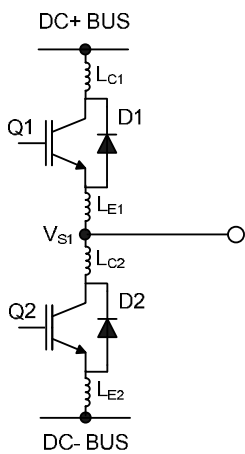

Figure 25: Parasitic Elements

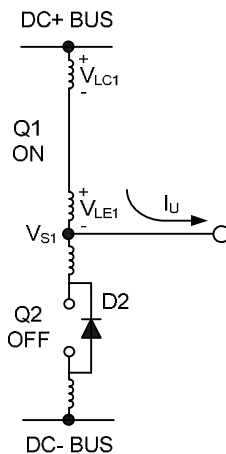

Figure 26: V_S positive

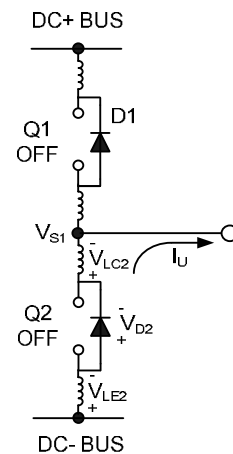

Figure 27: V_S negative

In a typical motor drive system, dV/dt is typically designed to be in the range of 3-5 V/ns. The negative V_S transient voltage can exceed this range during some events such as short circuit and over-current shutdown, when di/dt is greater than in normal operation.

International Rectifier's HVICs have been designed for the robustness required in many of today's demanding applications. An indication of the AUIRS2332J's robustness can be seen in Figure 28, where there is represented the AUIRS2332J Safe Operating Area at $V_{BS}=15V$ based on repetitive negative V_S spikes. A negative V_S transient voltage falling in the grey area (outside SOA) may lead to IC permanent damage; viceversa unwanted functional anomalies or permanent damage to the IC do not appear if negative V_S transients fall inside SOA.

At $V_{BS}=15V$ in case of $-V_S$ transients greater than $-16.5 V$ for a period of time greater than 50 ns; the HVIC will hold by design the high-side outputs in the off state for 4.5 μs .

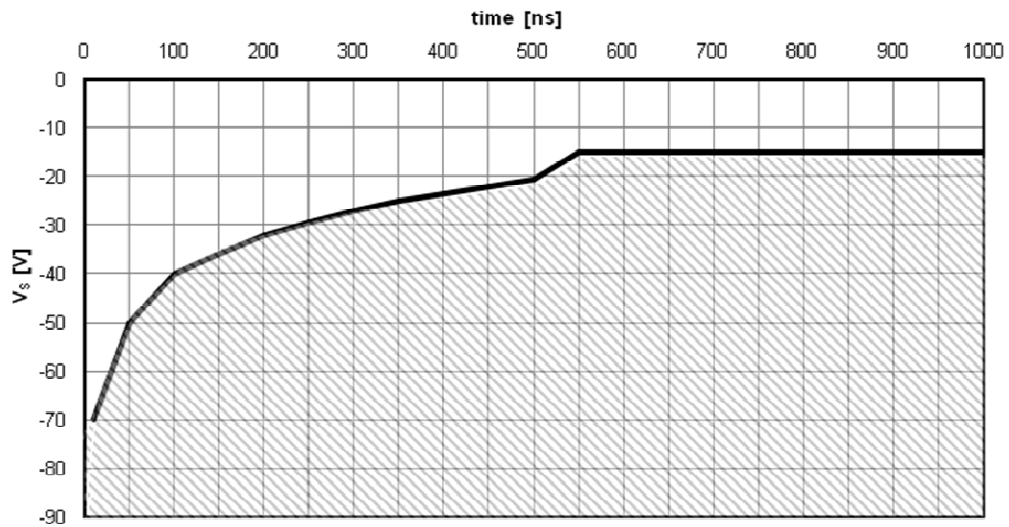

Figure 28: Negative V_S transient SOA for AUIRS2332J

Even though the AUIRS2332J has been shown able to handle these large negative V_S transient conditions, it is highly recommended that the circuit designer always limit the negative V_S transients as much as possible by careful PCB layout and component use.

DC- bus Current Sensing

A ground referenced current signal amplifier has been included so that the current in the return leg of the DC bus may be monitored. A typical circuit configuration is provided in Fig.29. The signal coming from the shunt resistor is amplified by the ratio $(R1+R2)/R2$. Additional details can be found on Design Tip DT 92-6. This design tip is available at www.irf.com.

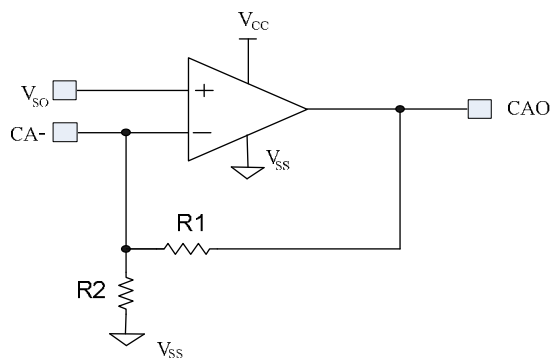

Figure 29: Current amplifier typical configuration

In the following Figures 30, 31, 32, 33 the configurations used to measure the operational amplifier characteristics are shown.

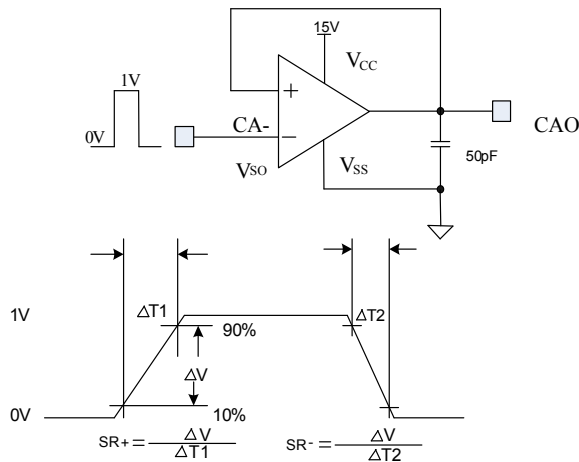

Figure 30: Operational Amplifier Slew rate measurement

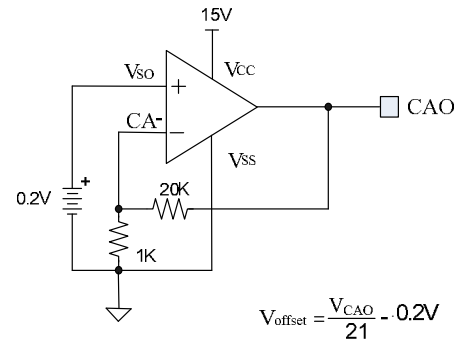

Figure 31: Operational Amplifier Input Offset Voltage measurement

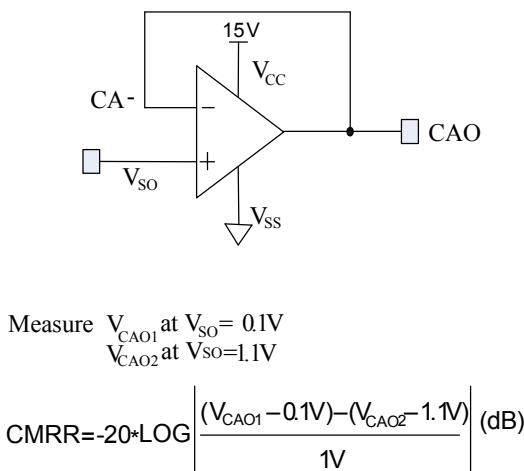

Figure 32: Operational Amplifier Common mode rejection measurement

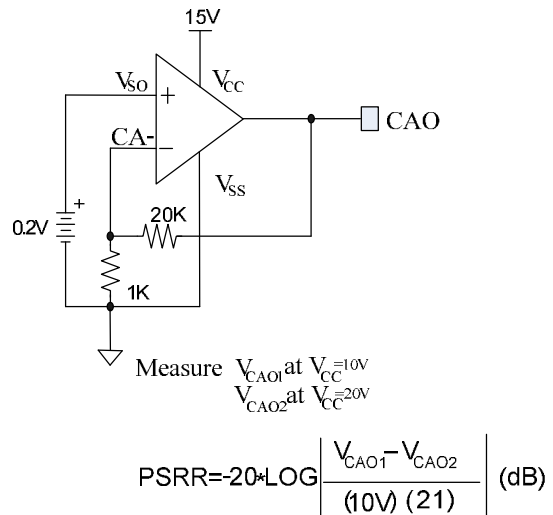

Figure 33: Operational Amplifier Power supply rejection measurement

PCB Layout Tips

Distance between high and low voltage components: It's strongly recommended to place the components tied to the floating voltage pins (V_B and V_S) near the respective high voltage portions of the device. The AUIRS2332J in the PLCC44 package has had some unused pins removed in order to maximize the distance between the high voltage and low voltage pins. Please see the Case Outline PLCC44 information in this datasheet for the details.

Ground Plane: In order to minimize noise coupling, the ground plane should not be placed under or near the high voltage floating side.

Gate Drive Loops: Current loops behave like antennas and are able to receive and transmit EM noise (see Figure 34). In order to reduce the EM coupling and improve the power switch turn on/off performance, the gate drive loops must be reduced as much as possible. Moreover, current can be injected inside the gate drive loop via the IGBT collector-to-gate parasitic

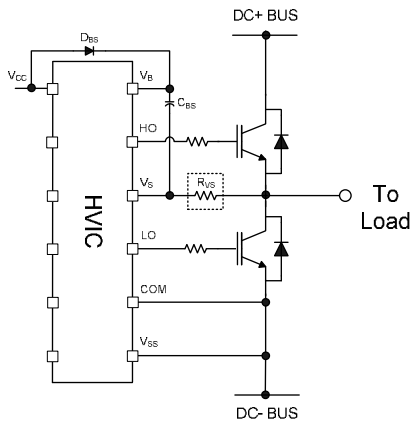

Figure 36: V_S resistor

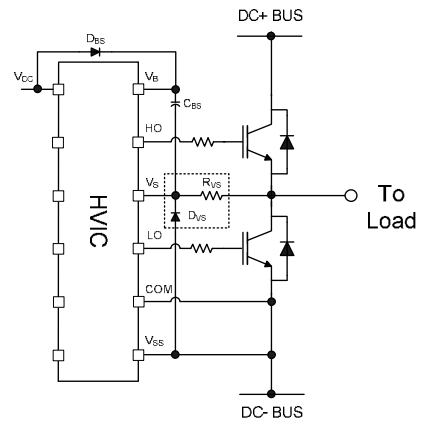

Figure 37: V_S clamping diode

Additional Documentation

Several technical documents related to the use of HVICs are available at www.irf.com; use the Site Search function and the document number to quickly locate them. Below is a short list of some of these documents.

- DT97-3: Managing Transients in Control IC Driven Power Stages
- AN-1123: Bootstrap Network Analysis: Focusing on the Integrated Bootstrap Functionality
- DT04-4: Using Monolithic High Voltage Gate Drivers
- AN-978: HV Floating MOS-Gate Driver ICs

Parameter Temperature Trends

Figures illustrated in this chapter provide information on the experimental performance of the AUIRS2332J HVIC. The line plotted in each figure is generated from actual lab data. A large number of individual samples were tested at three temperatures (-40 °C, 25 °C, and 125 °C) in order to generate the experimental curve. The line consists of three data points (one data point at each of the tested temperatures) that have been connected together to illustrate the understood trend. The individual data points on the Typ. curve were determined by calculating the averaged experimental value of the parameter (for a given temperature).

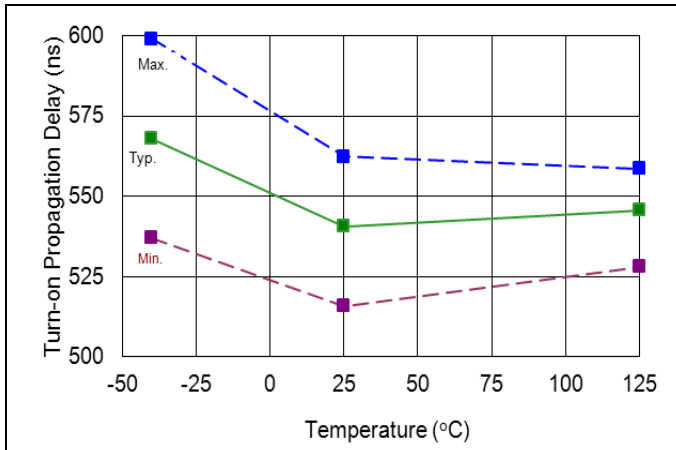

Figure 38. Turn-on propagation delay vs. temperature

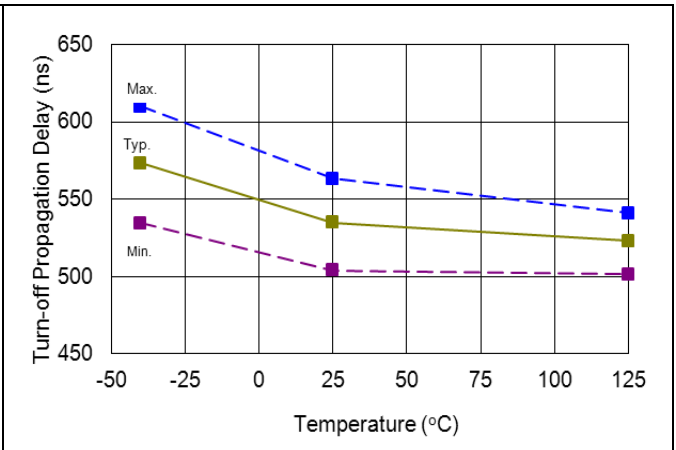

Figure 39. Turn-off propagation delay vs. temperature

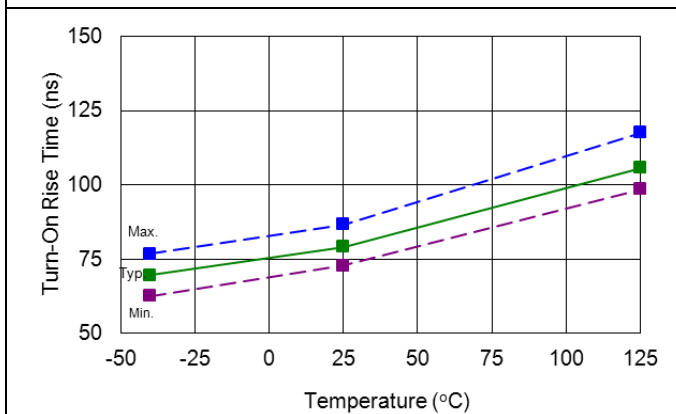

Figure 40. Turn-on rise time vs. temperature

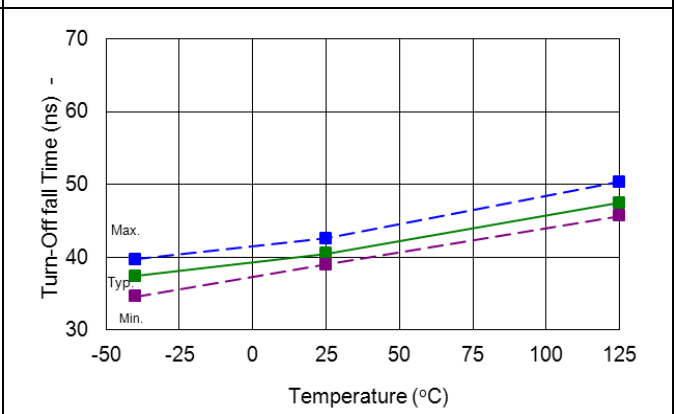

Figure 41. Turn-off fall time vs. temperature

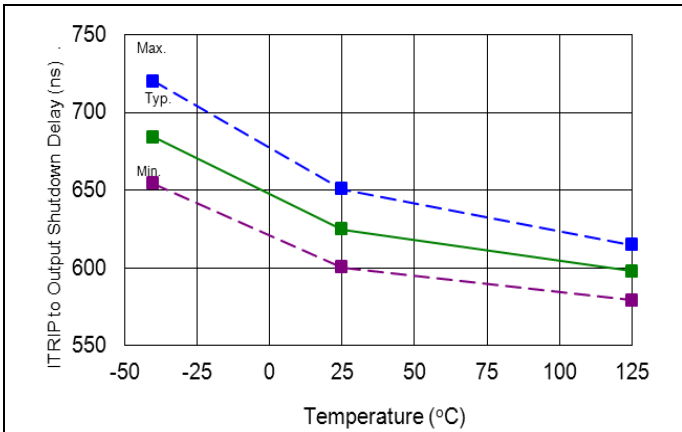

Figure 42. ITRIP to output shutdown propagation delay vs. temperature

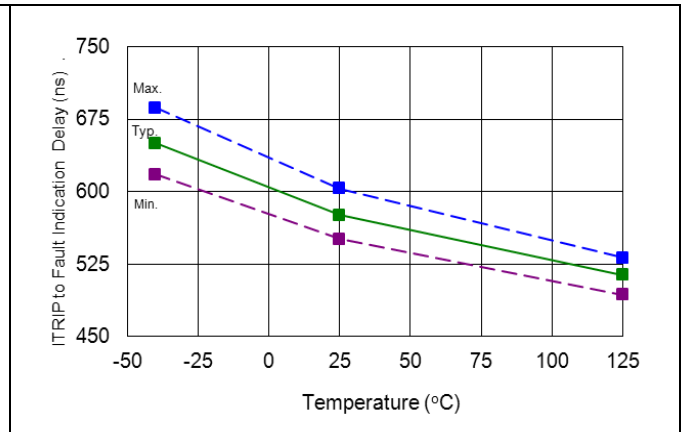

Figure 43. ITRIP to FAULT' indication delay vs. temperature

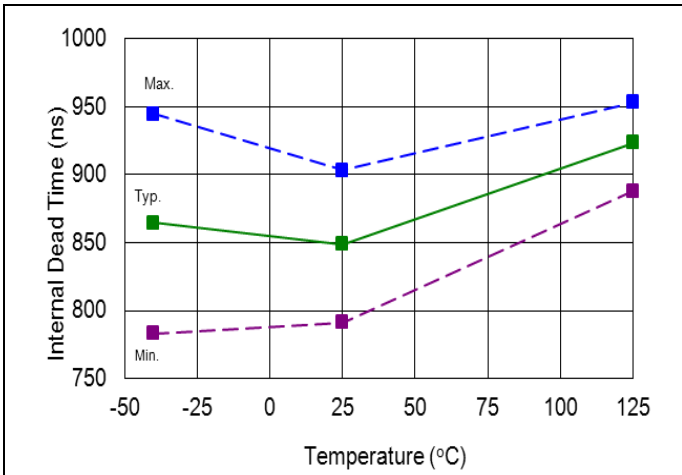

Figure 44. Dead time vs. temperature

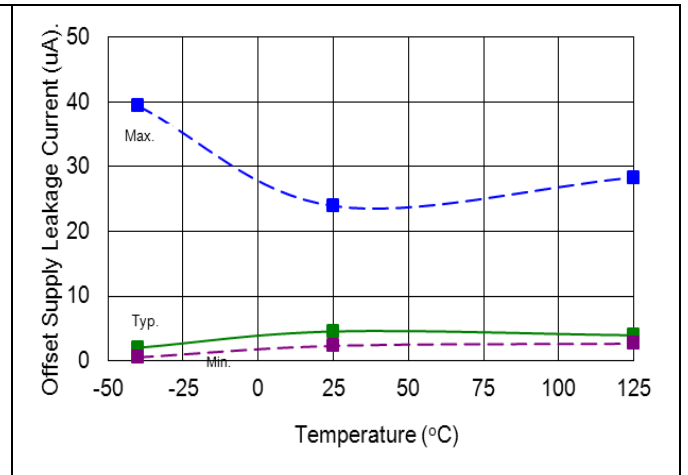

Figure 45. Offset supply leakage current vs. temperature

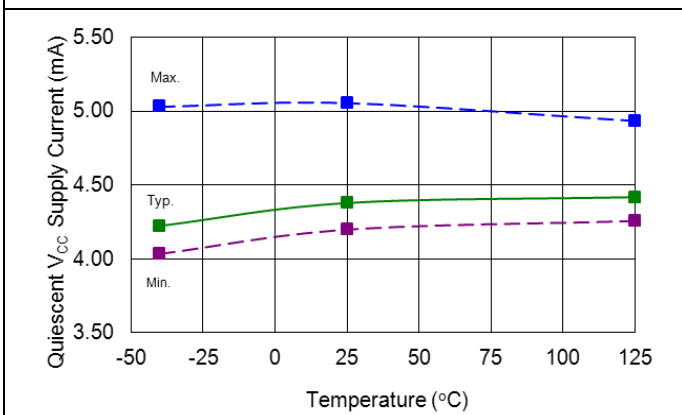

Figure 46. Quiescent V_{CC} supply current vs. temperature

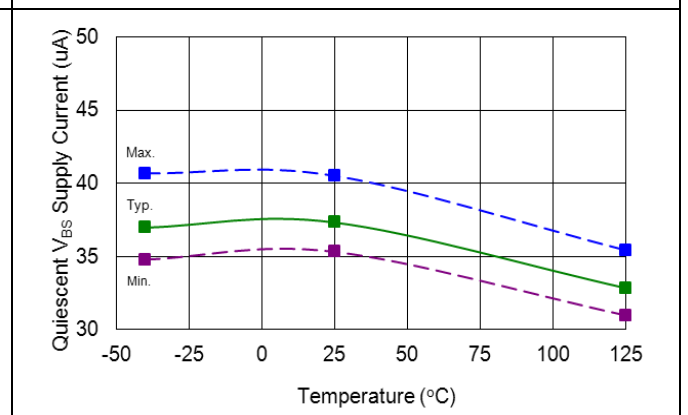

Figure 47. Quiescent V_{BS} supply current vs. temperature

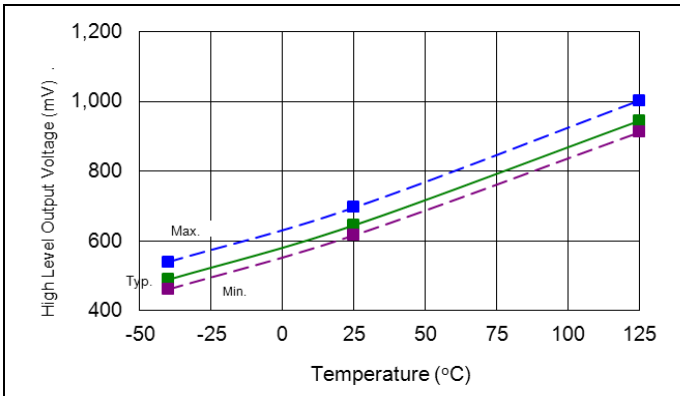

Figure 48. High level output voltage vs. temperature

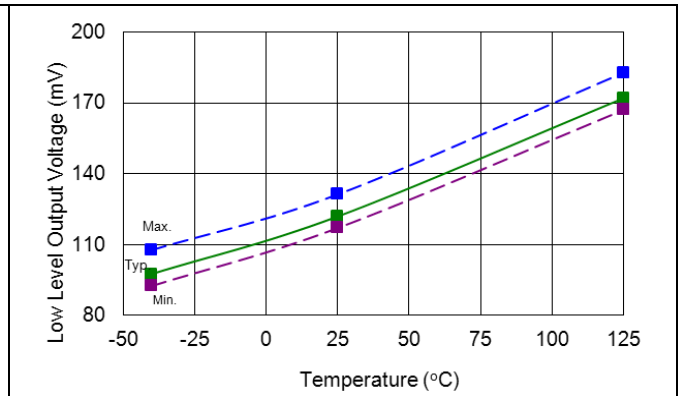

Figure 49. Low level output voltage vs. temperature

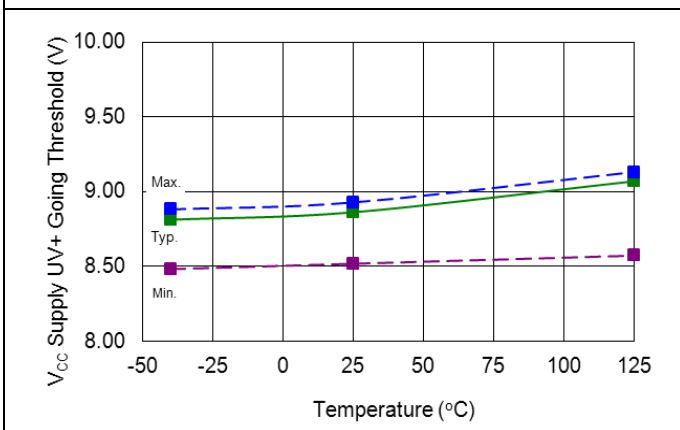

Figure 50. V_{CC} supply undervoltage positive going threshold vs. temperature

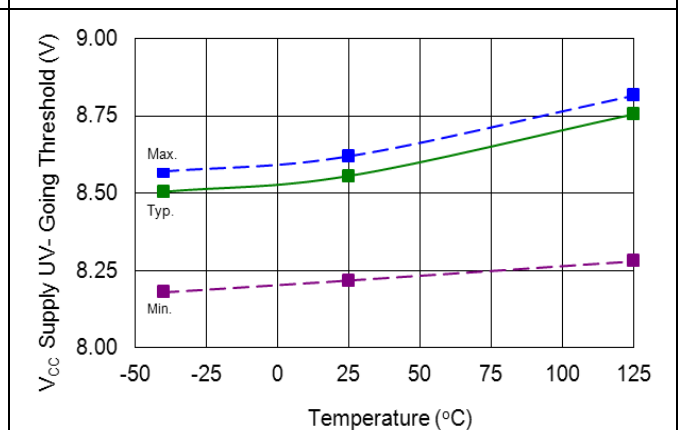

Figure 51. V_{CC} supply undervoltage negative going threshold vs. temperature

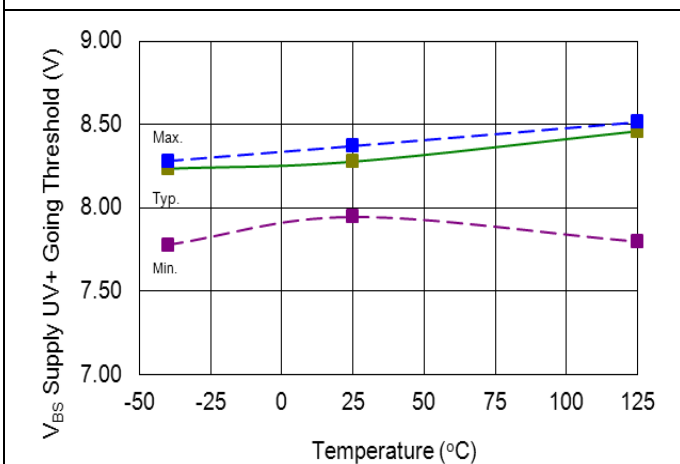

Figure 52. V_{BS} supply undervoltage positive going threshold vs. temperature

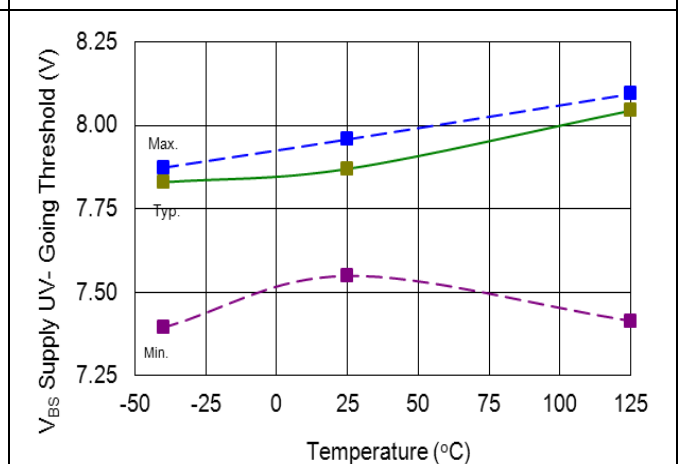

Figure 53. V_{BS} supply undervoltage negative going threshold vs. temperature

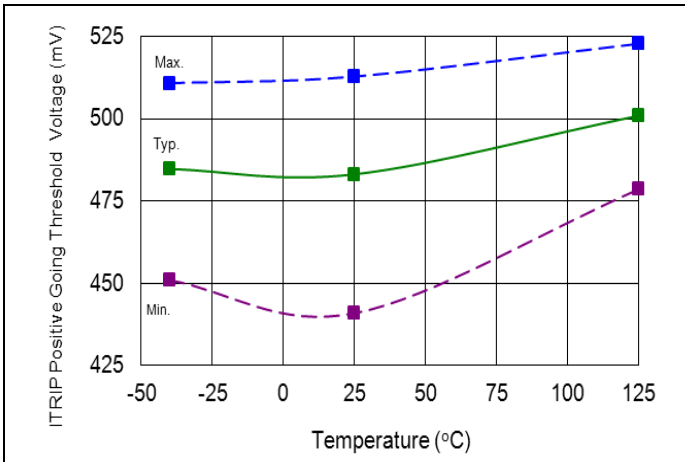

Figure 54. ITRIP input positive going threshold vs. temperature

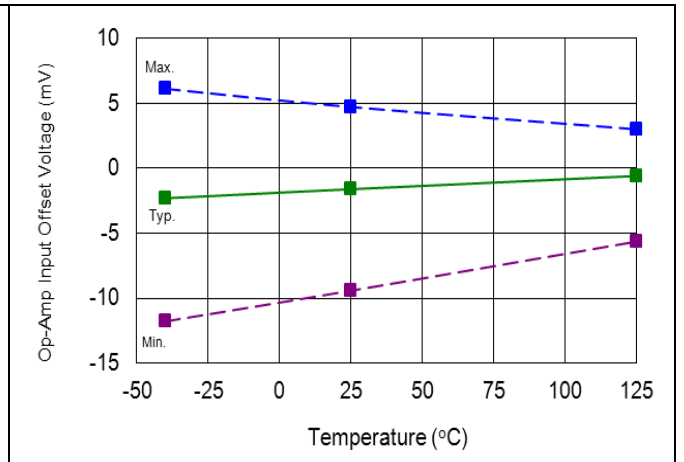

Figure 55. Op-amp input offset voltage vs. temperature

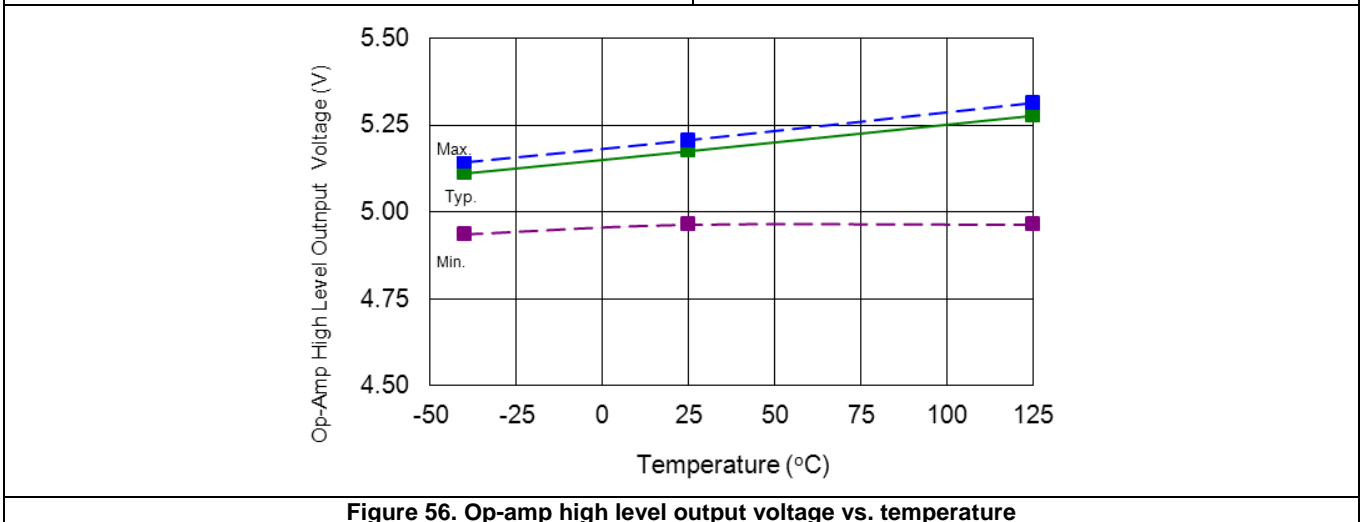
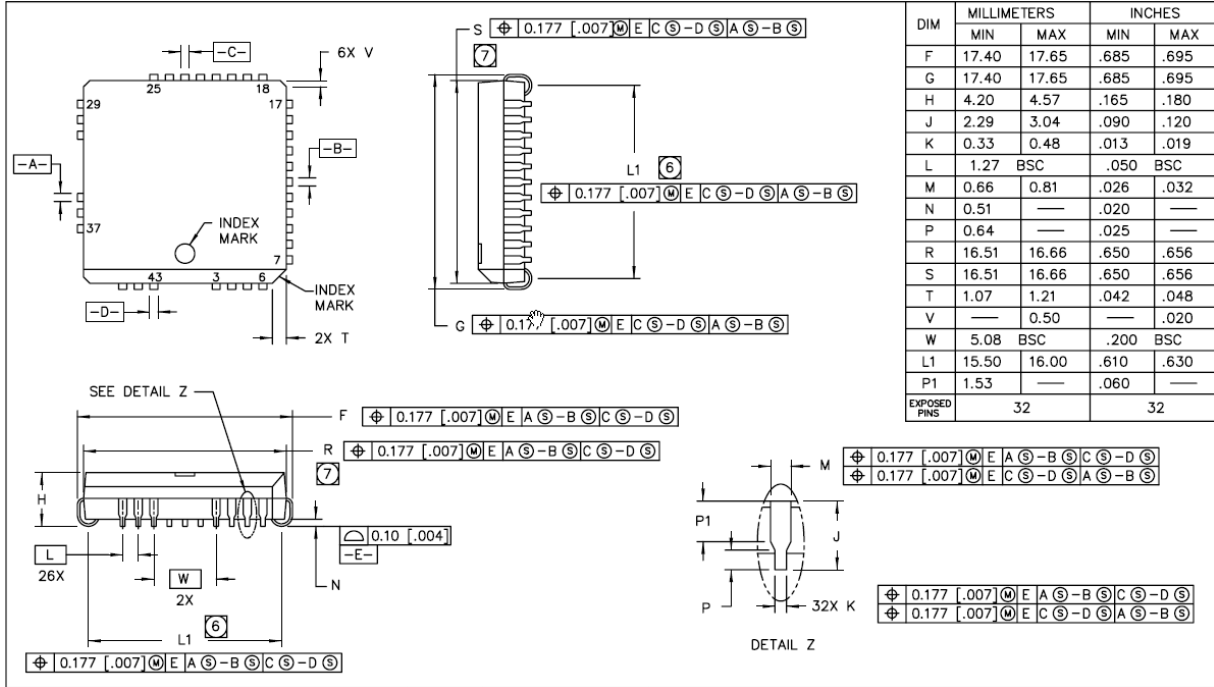

Figure 56. Op-amp high level output voltage vs. temperature

Case Outlines



NOTES:

1. DIMENSIONING & TOLERANCING PER ANSI Y14.5M-1982.
2. DIMENSIONS SHOWN IN MILLIMETERS [INCHES].
3. CONTROLLING DIMENSION: INCH.
4. CONFORMS TO JEDEC OUTLINE MS-018.
5. TO BE MEASURED AT -E- SEATING PLANE OF THE LEADS EXIT PLASTIC BODY AT MOLD PARTING LINE.
6. DATUMS -A-, -B-, -C-, & -D- ARE DETERMINED BY WHERE THE TOP
7. DIMENSIONS DO NOT INCLUDE MOLD FLASH, ALLOWABLE FLASH IS 0.254 [.010].

Package Land Pattern

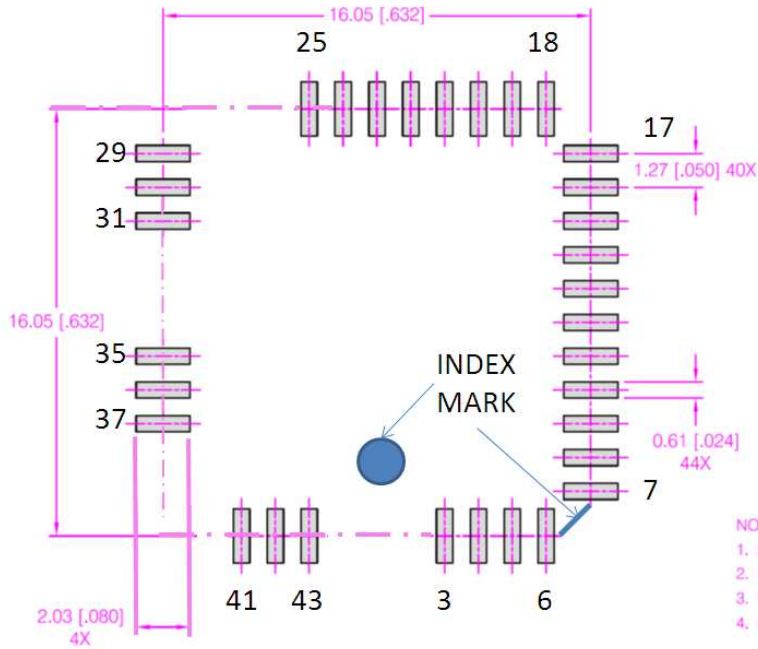

Tape and Reel Details: PLCC44

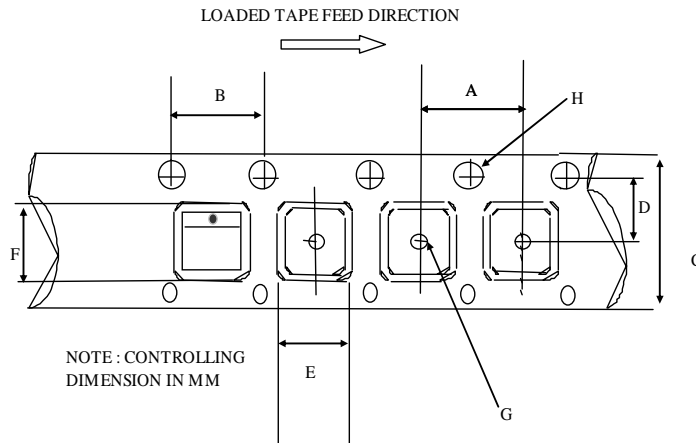

CARRIER TAPE DIMENSION FOR 44PLCC

Code	Metric		Imperial	
	Min	Max	Min	Max
A	23.90	24.10	0.94	0.948
B	3.90	4.10	0.153	0.161
C	31.70	32.30	1.248	1.271
D	14.10	14.30	0.555	0.562
E	17.90	18.10	0.704	0.712
F	17.90	18.10	0.704	0.712
G	2.00	n/a	0.078	n/a
H	1.50	1.60	0.059	0.062

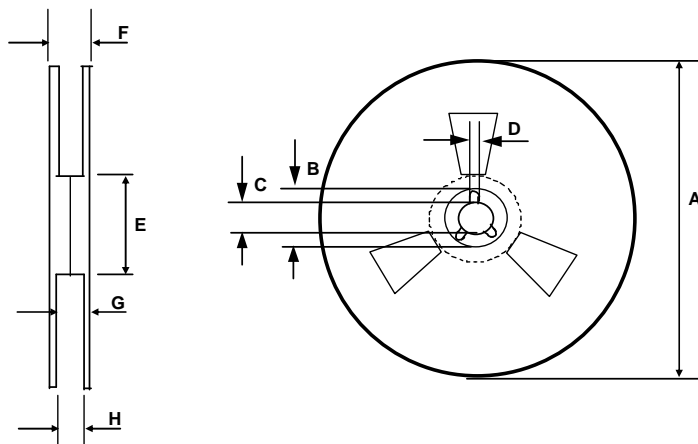

REEL DIMENSIONS FOR 44PLCC

Code	Metric		Imperial	
	Min	Max	Min	Max
A	329.60	330.25	12.976	13.001
B	20.95	21.45	0.824	0.844
C	12.80	13.20	0.503	0.519
D	1.95	2.45	0.767	0.096
E	98.00	102.00	3.858	4.015
F	n/a	38.4	n/a	1.511
G	34.7	35.8	1.366	1.409
H	32.6	33.1	1.283	1.303

Part Marking Information

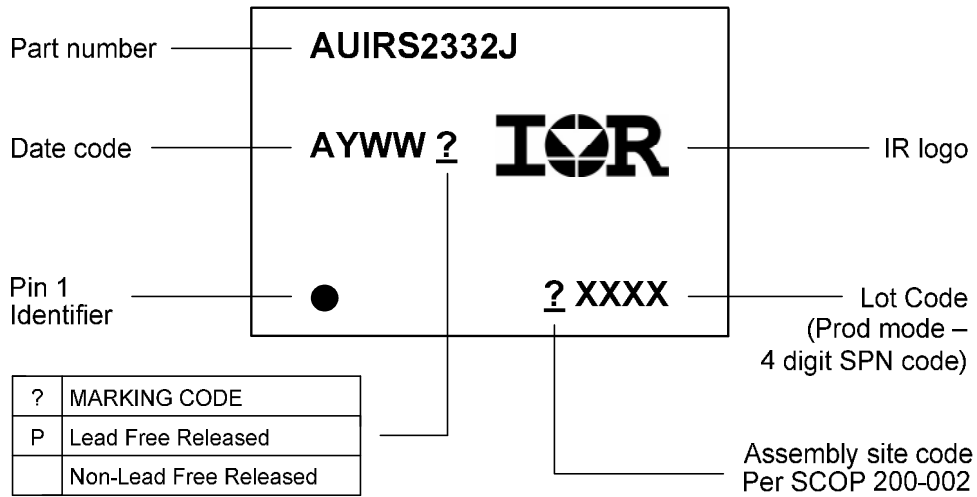

Ordering Information

Base Part Number	Package Type	Standard Pack		Complete Part Number
		Form	Quantity	
AUIRS2332J	PLCC44	Tube/Bulk	27	AUIRS2332J
		Tape and Reel	500	AUIRS2332JTR

IMPORTANT NOTICE

Unless specifically designated for the automotive market, International Rectifier Corporation and its subsidiaries (IR) reserve the right to make corrections, modifications, enhancements, improvements, and other changes to its products and services at any time and to discontinue any product or services without notice. Part numbers designated with the "AU" prefix follow automotive industry and / or customer specific requirements with regards to product discontinuance and process change notification. All products are sold subject to IR's terms and conditions of sale supplied at the time of order acknowledgment.

IR warrants performance of its hardware products to the specifications applicable at the time of sale in accordance with IR's standard warranty. Testing and other quality control techniques are used to the extent IR deems necessary to support this warranty. Except where mandated by government requirements, testing of all parameters of each product is not necessarily performed.

IR assumes no liability for applications assistance or customer product design. Customers are responsible for their products and applications using IR components. To minimize the risks with customer products and applications, customers should provide adequate design and operating safeguards.

Reproduction of IR information in IR data books or data sheets is permissible only if reproduction is without alteration and is accompanied by all associated warranties, conditions, limitations, and notices. Reproduction of this information with alterations is an unfair and deceptive business practice. IR is not responsible or liable for such altered documentation. Information of third parties may be subject to additional restrictions.

Resale of IR products or serviced with statements different from or beyond the parameters stated by IR for that product or service voids all express and any implied warranties for the associated IR product or service and is an unfair and deceptive business practice. IR is not responsible or liable for any such statements.

IR products are not designed, intended, or authorized for use as components in systems intended for surgical implant into the body, or in other applications intended to support or sustain life, or in any other application in which the failure of the IR product could create a situation where personal injury or death may occur. Should Buyer purchase or use IR products for any such unintended or unauthorized application, Buyer shall indemnify and hold International Rectifier and its officers, employees, subsidiaries, affiliates, and distributors harmless against all claims, costs, damages, and expenses, and reasonable attorney fees arising out of, directly or indirectly, any claim of personal injury or death associated with such unintended or unauthorized use, even if such claim alleges that IR was negligent regarding the design or manufacture of the product.

Only products certified as military grade by the Defense Logistics Agency (DLA) of the US Department of Defense, are designed and manufactured to meet DLA military specifications required by certain military, aerospace or other applications. Buyers acknowledge and agree that any use of IR products not certified by DLA as military-grade, in applications requiring military grade products, is solely at the Buyer's own risk and that they are solely responsible for compliance with all legal and regulatory requirements in connection with such use.

IR products are neither designed nor intended for use in automotive applications or environments unless the specific IR products are designated by IR as compliant with ISO/TS 16949 requirements and bear a part number including the designation "AU". Buyers acknowledge and agree that, if they use any non-designated products in automotive applications, IR will not be responsible for any failure to meet such requirements.

For technical support, please contact IR's Technical Assistance Center
<http://www.irf.com/technical-info/>

WORLD HEADQUARTERS:

101 N. Sepulveda Blvd., El Segundo, California 90245
Tel: (310) 252-7105

Revision History

Date	Comment
Jul. 7, 2010	Converted from industrial datasheet
July 28, 2010	Typ Application section updated in front page. Logic block diagram modified because UVVcc is not latched. Added Input Output equivalent circuit diagram
May 6, 2011	Added tri-temp graphs; updated qual info page and table of contents. Formated to AU DS format
May 11, 2011	Ton and toff typ values changed from 500ns to 540ns. Tf typ from 35ns to 40ns DT typ from 700ns to 850ns. Iqbs typ from 30uA to 37uA; Iqcc typ from 4.0uA to 4.5uA. ITRIP to Output Shutdown Propagation delay typ from 660ns to 625ns. VOH max from 1V to 1.1V. VCCUV+ typ from 9V to 8.9V; VCCUV- from 8.7V to 8.6V. VBSUV+ typ from 8.35V to 8.3V; VCCUV- from 7.95V to 7.9V.
May 11, 2011	lin+ min changed from -400 to -450; lin- min changed from -300 to -350; lo- min changed from 420 to 375; Tr max changed from 125 to 145; MDT max change from 140 to 145; VOH max changed from 1.1 to 1.15.
May 13, 2011	Changed formula in Figure 31
May 17, 2011	Updated CDM class
June 7, 2011	Added Rth _{JC}
June 24, 2011	Updated disclaimer
August 30 th , 2012	Updated Case Outline (more readable) and added Package Land Pattern
September, 3 rd , 2012	Added NC (not connected) in lead assignment figure and text. Package Land Pattern updated