

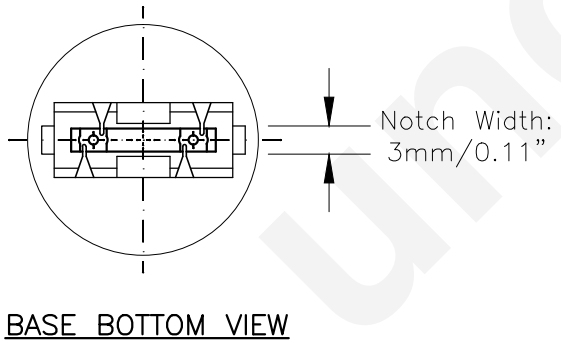

PART NO.	BASE TYPE	DESIGN VOLTS	DESIGN AMPS	MSCD	FILAMENT TYPE	AVERAGE LIFE HOURS	REVISIONS			
							REV #	DESCRIPTION	DATE	APPROVED
3157NA	D.F. Plastic Wedge W2.5X16q	12.8V 14.0V	2.10±5% 0.59±8%	24±30% 2.2±30%	C-6 C-6	1200 5000	1	ADDED FILAMENT DISTANCE DIMENSIONS	10/04/2018	R.M.

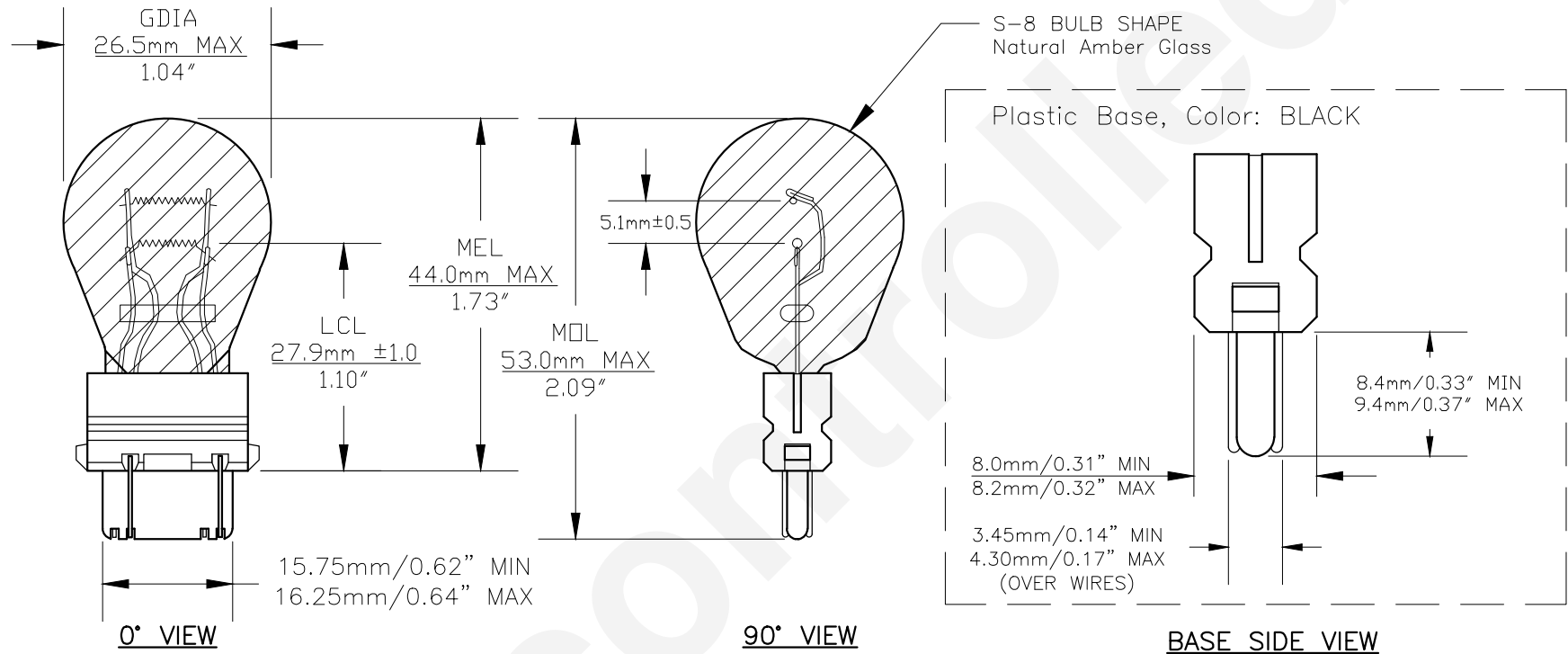

Note: Made according to SAE specifications



UNLESS OTHERWISE SPECIFIED: DIMENSIONS ARE IN INCHES TOLERANCES		CEC INDUSTRIES LTD			
DECIMALS	ANGULAR	599 BOND STREET		LINCOLNSHIRE, IL 60069	
.XX ± .05	± 0.5°	TITLE LIGHT BULB NO. 3157NA			
.XXX ± .010		SIZE A	FSCM NO.	DWG NO. 3157NA	REV 1
FRACTIONAL	±1/64	SCALE		PLOT SCALE	SHEET 1 OF 1
DRAWN SIDNEY LIU		DATE 10/30/2008		MATERIAL	
CHECKED		FILE 3157NA.pdf		DRAWING NOT TO SCALE	