

# Memory Module Temperature Sensor and Serial Presence Detect EEPROM

## PRODUCT FEATURES

Datasheet

### General Description

The EMC1501 is a combination temperature monitor and Serial Presence Detect (SPD) EEPROM compatible with the TSE2002av JEDEC Specification. It contains an internal temperature monitor as well as an integrated 2k bit EEPROM with two methods of software protection. This product is different from other devices in that it can operate at any of three voltage ranges (1.8V, 2.5V, or 3.3V). It provides accuracy beyond the JEDEC requirements and offers 1°C accuracy from 25°C to 100°C.

The low current consumption can be reduced using the software programmed shutdown mode. The EMC1501 contains programmable high, low, and critical temperature limits. Finally, the device EVENT pin can be configured as active high or active low and can be configured to operate as an interrupt or as a comparator output.

### Applications

- Dual In-line Memory Modules (DIMMs)
- Desktop and Mobile Computers
- Telecom

### Features

- Meets JEDEC Standard TSE2002av (JC-42.4) for Serial Presence Detect with Temperature Sensor
- Integrated 2k bit EEPROM
- Software EEPROM protection
  - Permanent and temporary software locks
- Event pin
- Internal Temperature Monitor
  - 1°C accuracy (25°C to 100°C)
- Programmable High, Low, and TCRIT Limits
- SMBus 2.0 and I<sup>2</sup>C Compliant 2-wire interface
  - Supports Page Read and Write operations

### Block Diagram

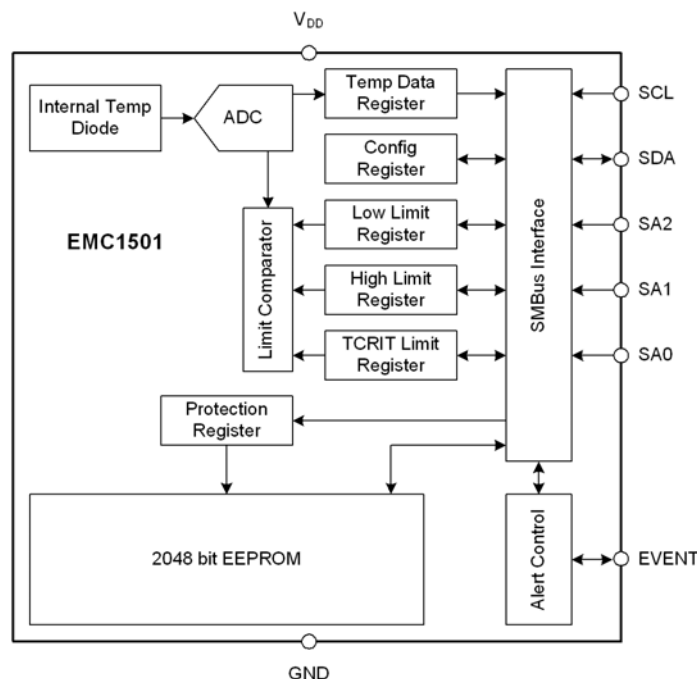

**ORDERING INFORMATION:**

<b>ORDERING NUMBER</b>	<b>PACKAGE</b>	<b>FEATURES</b>
EMC1501-1-AC3-TR	8 pin, TDFN 2mm x 3mm RoHS Compliant	Internal temperature sensor and 256 byte EEPROM with SW lock

**REEL SIZE IS 5,000 PIECES**

## Table of Contents

<b>Chapter 1</b>	<b>Pin Layout</b>	<b>7</b>
<b>Chapter 2</b>	<b>Electrical Specifications</b>	<b>8</b>
2.1	Electrical Specifications	8
<b>Chapter 3</b>	<b>Communications</b>	<b>11</b>
3.1	System Management Bus Interface Protocol	11
3.1.1	SMBus Start Bit	11
3.1.2	SMBus Address and RD / $\overline{\text{WR}}$ Bit	11
3.1.3	SMBus Data Bytes	11
3.1.4	ACK and NACK Bits	12
3.1.5	SMBus Stop Bit	13
3.1.6	SMBus Timeout	13
3.1.7	SMBus and I <sup>2</sup> C Compliance	14
3.2	Communications Protocols	14
3.2.1	SMBus Write Byte	14
3.2.2	SMBus Read Byte	14
3.3	Page Read	15
3.4	Page Write	15
3.5	EEPROM Write Cycle	15
3.6	SMBus Addressing	16
3.6.1	SWP and CWP Addresses	16
3.6.2	Protection Register	16
<b>Chapter 4</b>	<b>General Description</b>	<b>18</b>
4.1	Power Modes	18
4.2	EVENT	19
4.2.1	EVENT Modes	19
4.3	Serial Presence Detection	20
4.4	Serial Presence Detection Protection	20
4.4.1	Locking using the SWP and CWP Commands	20
4.4.2	Locking via Protection Register	20
4.5	Temperature Monitor	21
4.5.1	Temperature Limits	21
4.5.2	Temperature Data Format	21
<b>Chapter 5</b>	<b>Temperature Registers</b>	<b>23</b>
5.1	Capabilities Register	23
5.2	Configuration Register	25
5.3	High Limit Register	26
5.4	Low Limit Register	27
5.5	TCRIT Limit Register	27
5.6	Temperature Data Register	27
5.7	Manufacturer ID Register	28
5.8	Device ID / Revision Register	28
5.9	MCHP Configuration Register	28
5.10	One-Shot Register	29
<b>Chapter 6</b>	<b>EEPROM Data Set Registers</b>	<b>30</b>
6.1	EEPROM Data Set Registers	30
6.1.1	Example SPD Register Allocation	30

6.1.2	Register Data.....	31
6.2	Lock Description.....	31
<hr/>		
<b>Chapter 7</b>	<b>Package Information.....</b>	<b>32</b>
7.1	Package Marking.....	34
<hr/>		
<b>Chapter 8</b>	<b>Datasheet Revision History.....</b>	<b>35</b>

Datasheet

## List of Figures

Figure 1.1	Pin Diagram . . . . .	7
Figure 3.1	SMBus Timing Diagram . . . . .	11
Figure 4.1	EMC1501 System Diagram . . . . .	18
Figure 4.2	EVENT Modes . . . . .	20
Figure 7.1	2mm x 3mm TDFN-8 Package Drawing . . . . .	32
Figure 7.2	2mm x 3mm TDFN-8 Package Dimensions . . . . .	33
Figure 7.3	2mm x 3mm TDFN PCB Layout . . . . .	33
Figure 7.4	Package Marking . . . . .	34

## List of Tables

Table 1.1	Pin Description	7
Table 1.2	Pin Types	7
Table 2.1	Absolute Maximum Ratings	8
Table 2.2	Electrical Specifications	8
Table 2.3	SMBus Timing Specifications	10
Table 3.1	Protocol Format	11
Table 3.2	Write Acknowledge Behavior	12
Table 3.3	Read Acknowledge Behavior	13
Table 3.4	Protocol Format	14
Table 3.5	Write Byte Protocol	14
Table 3.6	Read Byte Protocol	14
Table 3.7	Page Read Protocol	15
Table 3.8	Page Write Protocol	15
Table 3.9	SMBus Addressing	17
Table 4.1	Temperature Data Format	21
Table 5.1	Temperature Register Set	23
Table 5.2	Capabilities Register	23
Table 5.3	TRES Bit Decode	24
Table 5.4	Configuration Register	25
Table 5.5	HYST Bit Decode	25
Table 5.6	High Limit Register	26
Table 5.7	Low Limit Register	27
Table 5.8	TCRIT Limit Register	27
Table 5.9	Temperature Data Register	27
Table 5.10	Manufacturer ID Register	28
Table 5.11	Device ID / Revision Register	28
Table 5.12	MCHP Configuration Register	28
Table 5.13	One-Shot Register	29
Table 6.1	EEPROM Data Set Registers	30
Table 8.1	Customer Revision History	35

## Datasheet

## Chapter 1 Pin Layout

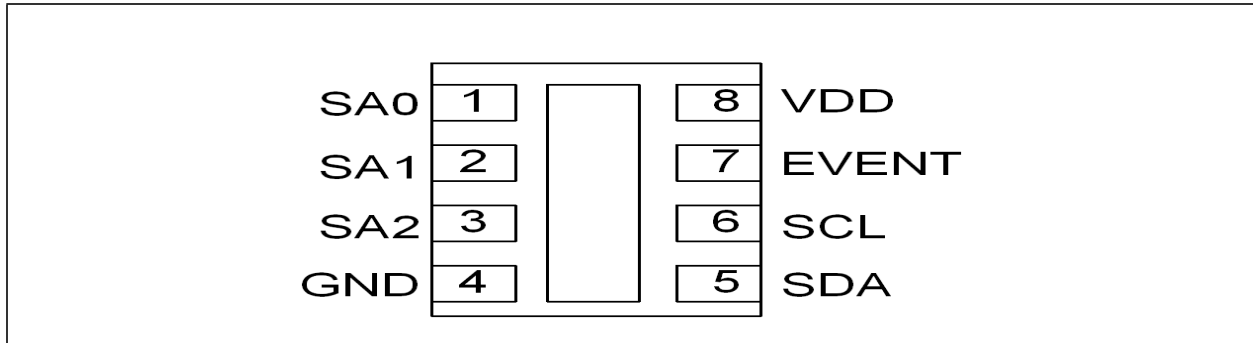

Figure 1.1 Pin Diagram

Table 1.1 Pin Description

PIN NUMBER	NAME	FUNCTION	TYPE
1	SA0	Address Selection Input - includes internal pull-down	DI (10V tolerant)
2	SA1	Address Selection Input - includes internal pull-down	DI
3	SA2	Address Selection Input - includes internal pull-down	DI
4	GND	Ground Connection	Power
5	SDA	SMBus Data Bi-directional Input - requires pull-up resistor to VDD	DIOD
6	SCL	SMBus Clock Input - requires pull-up resistor to VDD	DI
7	EVENT	Open Drain interrupt output - requires pull-up resistor	OD
8	VDD	Positive supply voltage	Power

Table 1.2 Pin Types

PIN TYPE	DESCRIPTION
DI	Digital Input
DIOD	Digital Input / Open Drain Output - This pin requires a pull-up resistor to VDD.
OD	Open Drain Output - This pin requires a pull-up resistor to VDD.
Power	This pin is used as a power supply input or ground.

## Chapter 2 Electrical Specifications

**Table 2.1 Absolute Maximum Ratings**

DESCRIPTION	RATING	UNIT
Supply Voltage ( $V_{DD}$ )	-0.5 to 4.3	V
Voltage on EVENT pin (see <a href="#">Note 2.1</a> )	-0.5 to $V_{DD} + 0.3$	V
Voltage on SA0 pin	-0.5 to 10	V
Voltage on any other pin to GND (see <a href="#">Note 2.1</a> )	-0.5 to $V_{DD} + 0.3$	V
Operating Temperature Range	-40 to +125	°C
Storage Temperature Range	-55 to +150	°C
Lead Temperature Range	Refer to JEDEC Spec. J-STD-020	
Package Thermal Characteristics for TDFN-8		
Thermal Resistance ( $\theta_{j-a}$ )	89	°C/W
ESD Rating, All pins HBM	2000	V

**Note:** Stresses at or above those listed could cause permanent damage to the device. This is a stress rating only and functional operation of the device at any other condition above those indicated in the operation sections of this specification is not implied.

**Note 2.1** For those pins that have a pull-up resistor, the difference in voltage from  $V_{PULLUP}$  to  $V_{DD}$  must not exceed 3.6V.

### 2.1 Electrical Specifications

**Table 2.2 Electrical Specifications**

$V_{DD} = 1.7V \text{ TO } 3.6V$ $T_A = -20^\circ\text{C TO } 125^\circ\text{C}$ , ALL TYPICAL VALUES AT $T_A = 27^\circ\text{C}$ UNLESS OTHERWISE NOTED.						
CHARACTERISTIC	SYMBOL	MIN	TYP	MAX	UNITS	CONDITIONS
DC Power						
Supply Voltage - Low Range	$V_{DD}$	1.7	1.8	1.9	V	
Supply Voltage - Middle Range	$V_{DD}$	2.3	2.5	2.7	V	
Supply Voltage - High Range	$V_{DD}$	3.0	3.3	3.6	V	



## Datasheet

Table 2.2 Electrical Specifications (continued)

$V_{DD} = 1.7V \text{ TO } 3.6V$ $T_A = -20^{\circ}C \text{ TO } 125^{\circ}C$ , ALL TYPICAL VALUES AT $T_A = 27^{\circ}C$ UNLESS OTHERWISE NOTED.						
CHARACTERISTIC	SYMBOL	MIN	TYP	MAX	UNITS	CONDITIONS
Supply Current	$I_{DD}$		500	1000	$\mu A$	8 conversion / sec, no EEPROM access
			20	100	$\mu A$	Standby mode (per JEDEC spec) Voltage on SA0 $\leq V_{DD}$ $0^{\circ}C < T_A < 95^{\circ}C$
				2	mA	EEPROM write access at 100kHz Temperature Monitoring disabled Page Write at 20 Hz rate.
				2	mA	EEPROM read access at 100kHz, Temperature Monitoring enabled
High Voltage Input	$V_{HV}$	7		10	V	$V_{HV} - V_{DD} \geq 4.8V$
Internal Temperature Monitor						
Temperature Accuracy			$\pm 0.5$	$\pm 1$	$^{\circ}C$	$25^{\circ}C < T_A < 100^{\circ}C$ (Active Range)
			$\pm 1$	$\pm 2$	$^{\circ}C$	$-20^{\circ}C < T_A < 125^{\circ}C$
Temperature Resolution			0.125		$^{\circ}C$	
SA0, SA1, SA2 Pins						
Input Impedance	$Z_{in}$	30			kOhm	$V_{IN} < 0.3 * V_{DD}$
	$Z_{in}$	800			kOhm	$V_{IN} > 0.7 * V_{DD}$
Input Low Voltage	$V_{IL}$	-	-	$0.3 * V_{DD}$	V	
Input High Voltage	$V_{IH}$	$0.7 * V_{DD}$	-	-	V	
Input Leakage Current	$I_{IH} / I_{IL}$			$\pm 5$	$\mu A$	Powered or unpowered $T_A < 85^{\circ}C$ , $V_{IN} = V_{DD}$ or $V_{SS}$
EVENT, SDA, SCL pins						
Output Low Voltage	$V_{OL}$	0.4			V	$I_{SINK} = 2.1mA$ ( $2.3 < V_{DD} \leq 3.6V$ )
		0.2			V	$I_{SINK} = 700\mu A$ ( $1.7 < V_{DD} \leq 2.3V$ )
Input Low Voltage	$V_{IL}$	-	-	$0.3 * V_{DD}$	V	
Input High Voltage	$V_{IH}$	$0.7 * V_{DD}$	-	-	V	
Input Leakage Current	$I_{IH} / I_{IL}$			$\pm 2$	$\mu A$	Powered or unpowered $T_A < 85^{\circ}C$ , $V_{IN} = V_{DD}$ or $V_{SS}$
Output Leakage Current	$I_{OH} / I_{OL}$			$\pm 2$	$\mu A$	$V_{OUT} = V_{DD}$ or $V_{SS}$
Input Capacitance	$C_{IN}$		5		pF	

Table 2.2 Electrical Specifications (continued)

V <sub>DD</sub> = 1.7V TO 3.6V T <sub>A</sub> = -20°C TO 125°C, ALL TYPICAL VALUES AT T <sub>A</sub> = 27°C UNLESS OTHERWISE NOTED.						
CHARACTERISTIC	SYMBOL	MIN	TYP	MAX	UNITS	CONDITIONS
EEPROM						
Sector Endurance	N <sub>END</sub>	10000			cycles	
Data Retention	t <sub>DR</sub>	100			yrs	
Read Time	t <sub>READ</sub>		1.5		us	
Program Time	t <sub>WRITE</sub>			9	ms	

Table 2.3 SMBus Timing Specifications

V <sub>DD</sub> = 1.7V to 3.6V, T <sub>A</sub> = -20°C - 125°C, Typical values are at T <sub>A</sub> = 27°C unless otherwise noted						
CHARACTERISTIC	SYMBOL	MIN	TYP	MAX	UNITS	CONDITIONS
Clock Frequency	f <sub>SMB</sub>	10		400	kHz	V <sub>DD</sub> > 2.3V
		10		100	kHz	V <sub>DD</sub> ≤ 2.3V
Spike Suppression	t <sub>SP</sub>			50	ns	
Bus free time Start to Stop	t <sub>BUF</sub>	1.3			us	
Hold Time: Start	t <sub>HD:STA</sub>	0.6			us	
Setup Time: Start	t <sub>SU:STA</sub>	0.6			us	
Setup Time: Stop	t <sub>SU:STO</sub>	0.6			us	
Data Hold Time	t <sub>HD:DAT</sub>	0.3			us	
Data Setup Time	t <sub>SU:DAT</sub>	100			ns	
Clock Low Period	t <sub>LOW</sub>	1.3			us	
Clock High Period	t <sub>HIGH</sub>	0.6			us	
Clock/Data Fall time	t <sub>FALL</sub>			300	ns	Min = 20+0.1C <sub>LOAD</sub> ns
Clock/Data Rise time	t <sub>RISE</sub>			300	ns	Min = 20+0.1C <sub>LOAD</sub> ns
Capacitive Load	C <sub>LOAD</sub>			400	pF	per bus line

## Chapter 3 Communications

### 3.1 System Management Bus Interface Protocol

The EMC1501 communicates with a host controller through the SMBus which is a two-wire serial communication protocol between a computer host and its peripheral devices. A detailed timing diagram is shown in Figure 3.1. Stretching of the SMCLK signal is supported; however, the EMC1501 will not stretch the clock signal.

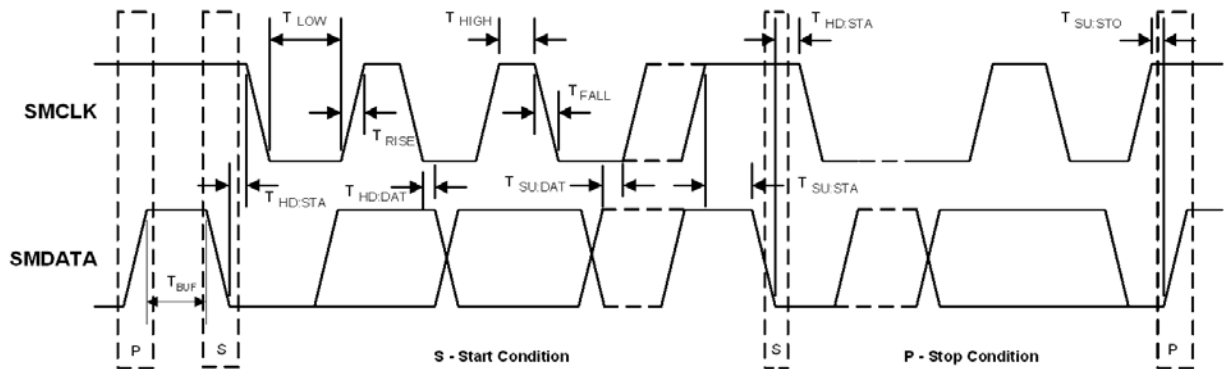

Figure 3.1 SMBus Timing Diagram

The EMC1501 is SMBus 2.0 compatible and supports the Read Byte, Write Byte, Page Read, and Page Write protocols as shown below.

#### 3.1.1 SMBus Start Bit

The SMBus Start bit is defined as a transition of the SMBus Data line from a logic '1' state to a logic '0' state while the SMBus Clock line is in a logic '1' state.

#### 3.1.2 SMBus Address and RD / $\overline{\text{WR}}$ Bit

The SMBus Address Byte consists of the 7-bit client address followed by the RD /  $\overline{\text{WR}}$  indicator bit. If this RD /  $\overline{\text{WR}}$  bit is a logic '0', the SMBus Host is writing data to the client device. If this RD /  $\overline{\text{WR}}$  bit is a logic '1', the SMBus Host is reading data from the client device.

The EMC1501 contains three SMBus addresses. See Section 3.9 for details.

#### 3.1.3 SMBus Data Bytes

All SMBus Data bytes are sent most significant bit first and composed of 8-bits of information.

Table 3.1 Protocol Format

DATA SENT TO DEVICE	DATA SENT TO THE HOST
# of bits sent	# of bits sent

### 3.1.4 ACK and NACK Bits

The ACK bit is used to indicate that a data byte was received properly. The client will drive the SDA pin low (thus acknowledging that it received the data) after it receives the 8-bit Slave Address (7-bit Slave Address plus the read or write bit) and again after it receives the register address. If the host is trying to write data to a register that is locked, the client will hold the SDA pin high after it receives the data byte (a NACK or not acknowledge signal) and will ignore the data.

Attempting to write to any locked bytes will cause the device to send a NACK bit and ignore data. Attempting to write data beyond a page boundary will cause the device to send a NACK bit and ignore data.

Table 3.2 shows the ACK and NACK behavior of the accessing options for Write commands while Table 3.3 shows the ACK and NACK behavior of the accessing options for Read commands.

**Note:** \*PSWP = Permanently Set Write Protection  
SWP = Set Write Protection  
CWP = Clear Write Protection

**Table 3.2 Write Acknowledge Behavior**

INSTRUCTION	STATUS	SLAVE ADDR		ADDR BYTE		DATA BYTE	
		DATA	ACK	DATA	ACK	DATA	ACK
Write PSWP*	Not Locked or locked w/ SWP	0110_XXX0	ACK	Don't Care	ACK	Don't Care	ACK
	Locked w/ PSWP	0110_XXX0	NACK	Don't Care	NACK	Don't Care	NACK
Write SWP*	Not Locked	0110_00H0	ACK	Don't Care	ACK	Don't Care	ACK
	Locked w/ SWP or PSWP	0110_00H0	NACK	Don't Care	NACK	Don't Care	NACK
Write CWP*	Not Locked or locked w/ PSWP	0110_01H0	NACK	Don't Care	NACK	Don't Care	NACK
	Locked w/ SWP	0110_01H0	ACK	Don't Care	ACK	Don't Care	ACK
Write EEPROM Data in lower 128 bytes	Not Locked	1010_XXX0	ACK	XXh	ACK	XXh	ACK (NACK if cross page boundary)
	Locked w/ SWP or PSWP	1010_XXX0	ACK	XXh	ACK	XXh	NACK
Write EEPROM Data in upper 128 bytes	n/a	1010_XXX0	ACK	XXh	ACK	XXh	ACK (NACK if cross page boundary)
Write Temperature Data	n/a	0011_XXX0	ACK	XXh	ACK	XXh	ACK

Table 3.3 Read Acknowledge Behavior

INSTRUCTION	STATUS	SLAVE ADDR		ADDR BYTE		REPEATED SLAVE ADDR	
		DATA	ACK	DATA	ACK	DATA	ACK
Read PSWP	Not Locked	0110_XXX0	ACK	Don't Care	ACK	0110_XXX1	NACK
	Locked w/ PSWP	0110_XXX0	NACK	Don't Care	NACK	0110_XXX1	NACK
	Locked w/ SWP	0110_XXX0	ACK	Don't Care	ACK	0110_XXX1	NACK
Read SWP	Not Locked	0110_00H0	ACK	Don't Care	ACK	0110_00H1	NACK
	Locked w/ PSWP	0010_00H0	NACK	Don't Care	NACK	0110_00H1	NACK
	Locked w/ SWP	0110_00H0	NACK	Don't Care	NACK	0110_00H1	NACK
Read CWP	Not Locked or locked w/ PSWP	0110_01H0	NACK	Don't Care	NACK	0110_01H1	NACK
	Locked w/ SWP	0110_01H0	ACK	Don't Care	ACK	0110_01H1	NACK
Read EEPROM Data	n/a	1010_XXX0	ACK	XXh	ACK	1010_XXX1	ACK
Read Temperature Data	n/a	0011_XXX0	ACK	XXh	ACK	0011_XXX1	ACK

**APPLICATION NOTE:** When reading the PSWP, SWP, or CWP, all bytes received will be NACK'd if the RD /  $\overline{\text{WR}}$  bit is set to a logic '1' indicating a read.

### 3.1.5 SMBus Stop Bit

The SMBus Stop bit is defined as a transition of the SMBus Data line from a logic '0' state to a logic '1' state while the SMBus clock line is in a logic '1' state. When the EMC1501 detects an SMBus Stop bit, and it has been communicating with the SMBus protocol, it will reset its client interface and prepare to receive further communications.

### 3.1.6 SMBus Timeout

The EMC1501 includes an SMBus timeout feature. Following a 30ms period of inactivity on the SMBus where the SMCLK pin is held low, the device will timeout and reset the SMBus interface.

The timeout function defaults to disabled. It can be enabled by setting the TIMEOUT bit in the Configuration register (see [Section 5.9](#)).

### 3.1.7 SMBus and I<sup>2</sup>C Compliance

The major difference between SMBus and I<sup>2</sup>C devices is highlighted here. For complete compliance information refer to the SMBus 2.0 specification.

1. Minimum frequency for SMBus communications is 10kHz. The I<sup>2</sup>C bus had no minimum frequency.
2. The client protocol will reset if the clock is held low longer than 30ms. The I<sup>2</sup>C bus may hold the clock low indefinitely.
3. The client protocol will reset if both the clock and the data line are high for longer than 150us (idle condition). The I<sup>2</sup>C bus is not required to reset except on a STOP bit.
4. The I<sup>2</sup>C Block Read and Write protocols do not use an additional data byte to indicate the number of data bytes that will be transmitted. Therefore, it may transmit as many bytes as desired provided that the bytes are ACK'd or NACK'd correctly. The EMC1501 only supports the I<sup>2</sup>C style block read and write.

## 3.2 Communications Protocols

The EMC1501 is SMBus 2.0 compatible and supports Read Byte and Write Byte as valid protocols as shown below. The EMC1501 also supports the I<sup>2</sup>C Page (Block) Read and Page (Block) Write protocols. The I<sup>2</sup>C Block Read and Block Write protocols, if used with two data bytes, function as a SMBus Word Read or Word Write protocols.

All of the below protocols use the convention in [Table 3.1](#).

**Table 3.4 Protocol Format**

DATA SENT TO DEVICE	DATA SENT TO THE HOST
Data sent	Data sent

### 3.2.1 SMBus Write Byte

The Write Byte is used to write one byte of data to a specific register as shown in [Table 3.5](#).

**Table 3.5 Write Byte Protocol**

START	CLIENT ADDRESS	WR	ACK	REGISTER ADDRESS	ACK	REGISTER DATA	ACK	STOP
1 -> 0	0011_XXX	0	0	XXh	0	XXh	0	0 -> 1

### 3.2.2 SMBus Read Byte

The Read Byte protocol is used to read one byte of data from the registers as shown in [Table 3.6](#).

**Table 3.6 Read Byte Protocol**

START	CLIENT ADDRESS	WR	ACK	REGISTER ADDRESS	ACK	START	CLIENT ADDRESS	RD	ACK	REGISTER DATA	NACK	STOP
1->0	0011_XXX	0	0	XXh	0	1 -> 0	0011_XXX	1	0	XXh	1	0 -> 1

## Datasheet

### 3.3 Page Read

The Page Read protocol is used to read data from up to sixteen (16) consecutive registers. This protocol is an extension of the Read Byte and Receive Byte protocols. After a data byte is received by the host, instead of sending a NACK bit, the host sends an ACK bit prompting the client to send another data byte. So long as the host sends an ACK bit after the data byte, the client will continue to send data bytes.

Table 3.7 shows a partial example of the Block Read command starting with the Read Byte protocol while.

**Table 3.7 Page Read Protocol**

START	CLIENT ADDRESS	WR	ACK	REGISTER ADDRESS	ACK	START	CLIENT ADDRESS	RD	ACK	REGISTER DATA
1->0	1010_XXX	0	0	XXh	0	1->0	0011_XXX	1	0	XXh
ACK	REGISTER DATA	ACK	REGISTER DATA	ACK	REGISTER DATA	ACK	...	REGISTER DATA	NACK	STOP
0	XXh	0	XXh	0	XXh	0	...	XXh	1	0->1

### 3.4 Page Write

The Page Write protocol is used to write data to sixteen (16) consecutive registers. This protocol is an extension of the Write Byte protocol and is partially shown in Table 3.8. After the host sends a data byte and the slave sends the ACK bit, the host will send additional data bytes, each followed by an ACK from the client. When the host has sent the last data byte, it will send the stop bit normally and end the transaction.

The EMC1501 EEPROM contains 16 pages each consisting of 16 bytes. The device will roll over across page boundaries; however, it will NACK all data bytes received that are beyond the page boundary of the write and discard all received data. This will occur regardless of where within the page the write is originated.

**Table 3.8 Page Write Protocol**

START	CLIENT ADDRESS	WR	ACK	REGISTER ADDRESS	ACK	REGISTER DATA	ACK
1->0	1010_XXX	0	0	XXh	0	XXh	0
REGISTER DATA	ACK	REGISTER DATA	ACK	...	REGISTER DATA	ACK	STOP
XXh	0	XXh	0	...	XXh	0	0->1

### 3.5 EEPROM Write Cycle

When the host is communicating with the EEPROM Data Set and it sends the stop bit the EEPROM will undergo its internal write cycle. When this occurs, it cannot receive any more data until the write cycle is complete.

If the host has sent the stop bit, the EEPROM Data Set will not respond to its SMBus address until the write cycle is completed. Once the write cycle has been completed, the device will respond normally. If the host has not sent the stop bit, all subsequent data bytes will be ignored.

## 3.6 SMBus Addressing

The EMC1501 contains multiple functional SMBus addresses depending on the functionality that is being accessed as shown in Table 3.9. The device supports SMBus activity to access Temperature Monitor controls independently of EEPROM data and the SA2, SA1, and SA0 pins apply to both addresses simultaneously.

### 3.6.1 SWP and CWP Addresses

The SWP (Set Write Protection) and CWP (Clear Write Protection) Commands act as a non-volatile, non-permanent software lock. The SWP Command (Set Write Protection) is invoked by writing to SMBus Address 0110\_001x while driving the SA0 pin to a high voltage state ( $V_{HV}$ ). Once the SWP command has been set, the lower 128 bytes of data will be locked and cannot be accessed.

The CWP Command is used to clear the previous SWP Command. If no SWP Command has been sent, then this command will do nothing. The CWP Command is invoked by writing to SMBus Address 0110\_011 while driving the SA0 pin to a high voltage state ( $V_{HV}$ ).

When sending the SWP and CWP addresses, only one device can be accessed at a time.

**APPLICATION NOTE:** The SWP and CWP commands can only be sent when the SA0 pin is driven to a high voltage upon device power up. If it is driven to a high voltage after device power up, then it will not be detected and a PSWP command will be sent.

**APPLICATION NOTE:** The SWP and CWP commands do not require the SA2 and SA1 pins to be tied to '00' and '01' respectively. All that these commands require is that the SA0 pin be pulled to a high voltage upon device power up. However, the SMBus Master must still transmit the appropriate SMBus slave address to invoke these commands (0110\_0010 for SWP command and 0110\_0110 for CWP command).

### 3.6.2 Protection Register

The EEPROM data can be permanently "locked" by accessing the Protection Register. The Protection Register is accessed using SMBus address 0110\_000xb through 0110\_111xb (set by the SA2, SA1, and SA0 pins). Writing to the Protection Register will lock the lower 128 bytes of the EEPROM Data Set. This state is non-volatile and cannot be reversed. Attempting to write to the Protection Register when the device is "locked" will cause the EMC1501 to send a NACK bit in response to the slave address.

Reading from the Protection Register will not cause the data to be locked; however it will be NACK'd.

**APPLICATION NOTE:** The SWP and CWP commands require that the SA0 pin be at a high voltage during power up. However, if the SA2 and SA1 are not '00' or '01' then writing to the Protection register with SA0 at a high voltage will still invoke the PSWP command. If the SA2 and SA1 pins are at '00' or '01', writing to the Protection Register will invoke the SWP or CWP commands respectively.



## Datasheet

Table 3.9 SMBus Addressing

FUNCTIONALITY ACCESSED	BASE ADDRESS	SA2	SA1	SA0	SMBUS ADDRESS
					BINARY
Temperature Monitor	0011b (3h)	VSS	VSS	VSS	0011_000x
		VSS	VSS	VDD	0011_001x
		VSS	VDD	VSS	0011_010x
		VSS	VDD	VDD	0011_011x
		VDD	VSS	VSS	0011_100x
		VDD	VSS	VDD	0011_101x
		VDD	VDD	VSS	0011_110x
		VDD	VDD	VDD	0011_111x
EEPROM Data	1010b (Ah)	VSS	VSS	VSS	1010_000x
		VSS	VSS	VDD	1010_001x
		VSS	VDD	VSS	1010_010x
		VSS	VDD	VDD	1010_011x
		VDD	VSS	VSS	1010_100x
		VDD	VSS	VDD	1010_101x
		VDD	VDD	VSS	1010_110x
		VDD	VDD	VDD	1010_111x
Protection Register (permanent)	0110b (6h)	SA2	SA1	SA0	0110_000x through 0110_111x
Protection Register (SWP)	0110b (6h)	VSS	VSS	VHV	0110_001x
Protection Register (CWP)	0110b (6h)	VSS	VDD	VHV	0110_011x

## Chapter 4 General Description

The EMC1501 is a combination temperature monitor and Serial Presence Detect EEPROM compatible with the TSE2002av JEDEC Specification. It contains an internal temperature monitor as well as an integrated 2k bit EEPROM with two methods of software protection. This product is different from other devices in that it can operate at any of three voltage ranges (1.8V, 2.5V, or 3.3V). It provides accuracy beyond the JEDEC requirements and offers 1°C accuracy from 25°C to 100°C.

The EMC1501 EEPROM module contains 2048 bits of non-volatile memory that can be write protected. Both functions, EEPROM and temperature sensor, are controlled independently of each other via the 2-wire SMBus communications protocol. Each uses a different SMBus address so that cross communications are not possible.

A system diagram is shown in [Figure 4.1](#).

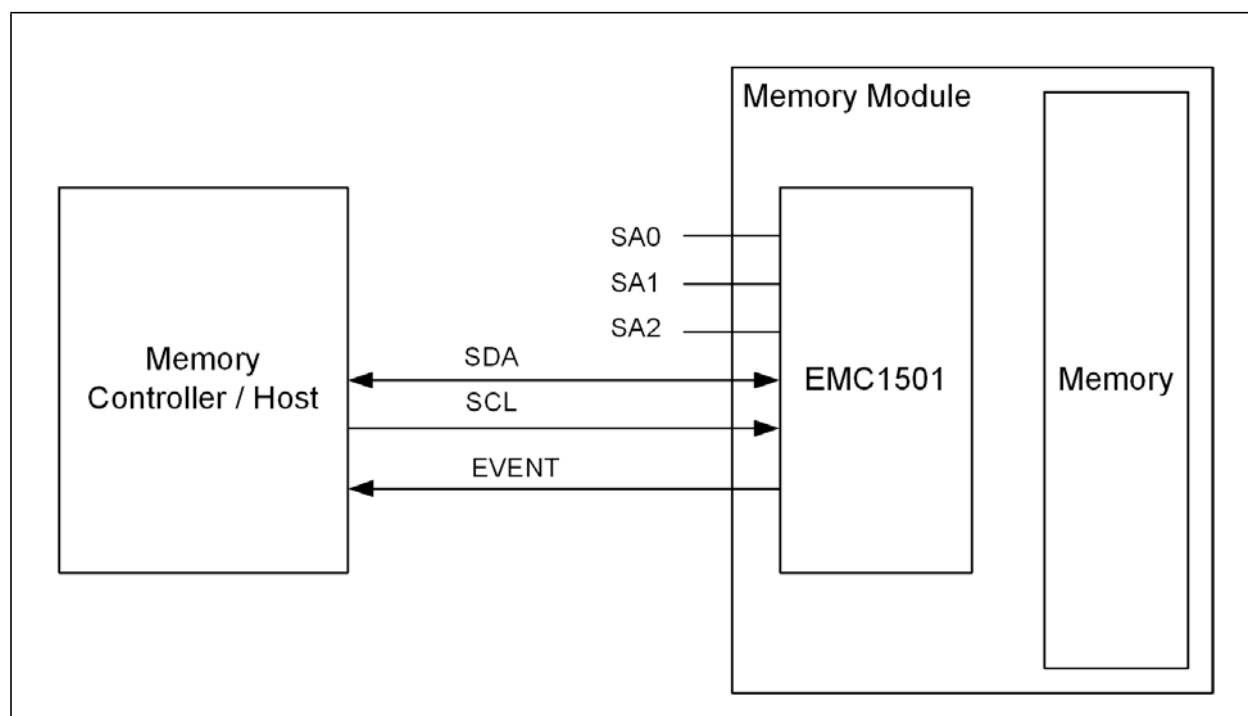

Figure 4.1 EMC1501 System Diagram

### 4.1 Power Modes

The EMC1501 contains three modes of operation. They are:

1. Full Power Mode - In this mode of operation, the device is monitoring temperature and the EEPROM block is being actively accessed.
2. Temperature Only - In this mode of operation, the device is monitoring temperature and the EEPROM block is not being accessed.
3. Standby - In this mode of operation, the device is not monitoring temperature data. Access to all register data and the EEPROM block is permitted. This mode is entered by setting the SHDN bit in the Configuration Register (see [Section 5.2](#)).

## Datasheet

## 4.2 EVENT

The EVENT pin is an open-drain digital I/O. During normal operation, the pin acts as an open-drain interrupt output with programmable polarity. This pin is asserted to the “active” state as set by the EVENT\_POL bit in the Configuration Register (see [Section 5.2](#)) whenever the temperature crosses one of the programmed thresholds.

### 4.2.1 EVENT Modes

The EMC1501 EVENT pin has three operating states during normal operation. These states depend on user programmed settings as well as the out-of-limit conditions that are present.

1. Interrupt Mode - In this mode, the EVENT pin will remain asserted until the CLEAR bit in the Configuration Register is written (see [Section 5.2](#)). Once the pin is cleared by the host, it will remain cleared until a different interrupt condition is met. This mode is not used when the temperature is compared against the TCRIT limit (see [Section 5.5](#)).
2. Comparator Mode - In this mode, the EVENT pin will clear itself when the error condition that caused the pin to be asserted is removed. When configured in Comparator Mode, the CLEAR bit is ignored. When the temperature is compared against the TCRIT limit, this mode is always used. This is the default operating mode.

**APPLICATION NOTE:** If the EVENT pin operating state is changed from Comparator Mode to Interrupt Mode while the measured temperature is above the high limit or below the low limit, then the EVENT pin will be released immediately regardless of whether the CLEAR bit has been written or not.

**APPLICATION NOTE:** If the EVENT pin operating state is changed from Interrupt Mode to Comparator Mode while the measured temperature is above the high limit or below the low limit, then the EVENT pin will be released immediately.

3. TCRIT Only Mode - In this mode, the EVENT pin will only be asserted if the measured temperature exceeds the TCRIT Limit. Once the pin has been asserted, it will remain asserted until the temperature drops below the TCRIT Limit minus the TCRIT hysteresis.

[Figure 4.2](#) shows the three interrupt modes.

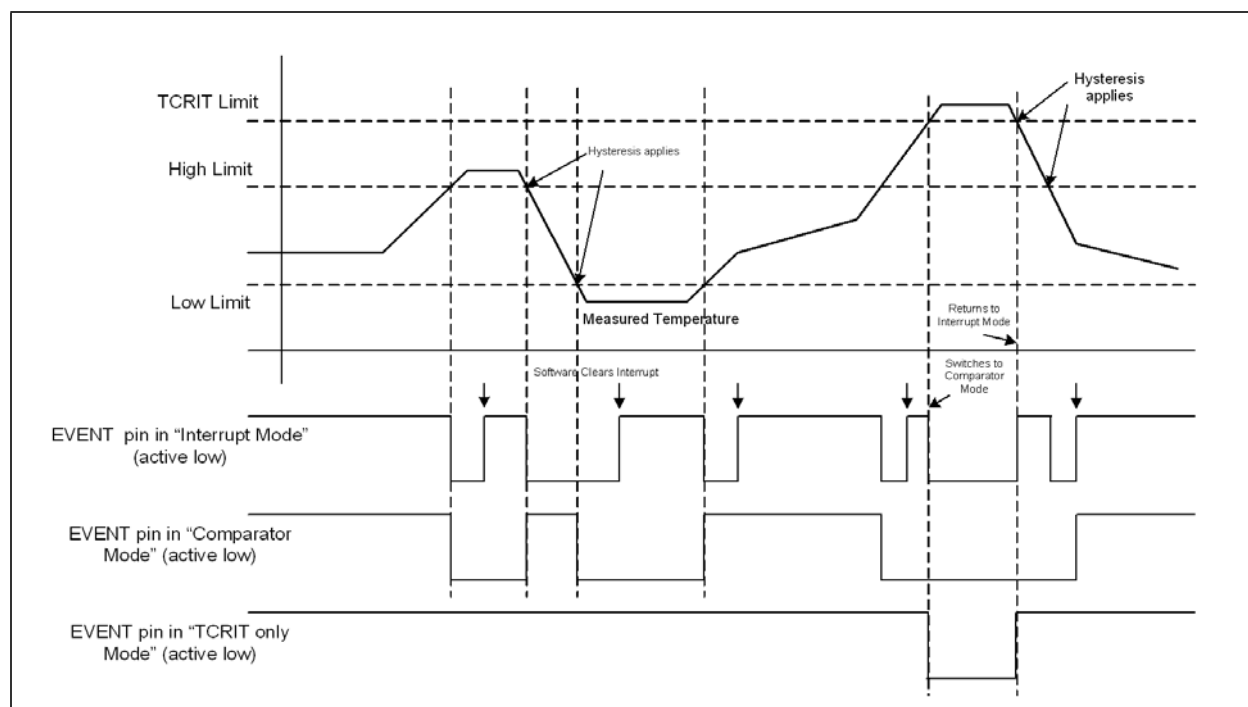

Figure 4.2 EVENT Modes

### 4.3 Serial Presence Detection

The EMC1501 Serial Presence Detection functionality contains 2048 bits of user definable EEPROM memory that is used to identify the memory size, type, and special operating conditions of the Memory Module. This information is placed in the lower 128 bytes of EEPROM storage and can be protected from being written by future applications. The upper 128 bytes of EEPROM storage are available for scratch pad use by any application.

### 4.4 Serial Presence Detection Protection

There are three methods to protect the lower 128 bytes of data in the EEPROM. The first mechanism is a software programmed, non-permanent lock accessed via the register set. The second mechanism is a non-permanent lock initiated using the SWP Command. The third and final mechanism is a permanent lock initiated by writing to the Protection Register. These methods are not exclusive and multiple methods can be used simultaneously.

#### 4.4.1 Locking using the SWP and CWP Commands

The EMC1501 supports a non-volatile, clearable software lock using the SWP and CWP Commands. When the SWP Command is issued, the lower 128 bytes of data in the EEPROM Data Set is locked and cannot be updated. This lock is only cleared using the CWP Command. See [Section 3.6.1](#).

#### 4.4.2 Locking via Protection Register

The EMC1501 EEPROM data can be locked via software by writing to the Protection Register. Any write to the Protection Register (accessed at base address 0110), regardless of the data written, will

**Datasheet**

lock the lower 128 bytes of the EEPROM data set. This data lock is permanent and cannot be reversed.

## 4.5 Temperature Monitor

The EMC1501 contains an internal temperature monitor. This temperature monitor measures the ambient die temperature of the device and updates the data registers. In addition, it compares this temperature against user-programmed limits to flag out-of-limit conditions or critical temperature conditions.

The EMC1501 updates the temperature data at a fixed update rate of 8 measurements per second.

### 4.5.1 Temperature Limits

The EMC1501 contains three user programmable temperature limits each with hysteresis.

The High and Low Limits are used to form an operating window. Whenever the temperature measurement crosses the threshold of this window (either on the high or low side), the EVENT pin is asserted. When configured in Interrupt Mode, the pin will remain asserted until it is cleared by the host. If configured in Comparator Mode, the pin will be released when the temperature returns to within the programmed window.

The TCRIT Limit is used to used as an absolute temperature limit. Whenever the temperature measurement crosses the TCRIT Limit, the EVENT pin will be asserted and remain asserted until the temperature drops below the limit minus hysteresis.

**APPLICATION NOTE:** The hysteresis applies for all of the temperature limits in the same direction. This means that an interrupt condition is generated when the temperature drops below the respective limit minus the hysteresis or meets or exceeds the respective limit.

### 4.5.2 Temperature Data Format

The EMC1501 reports data in a range from -64°C to +191.875°C with 0.125°C resolution. The format is standard 2's complement format as shown in [Table 4.1](#).

**Table 4.1 Temperature Data Format**

TEMPERATURE (C)	DATA	
	HEX	BINARY
≤ -64	1C_00h	xxx1 1100 0000 000xb
-63.75	1C_04x	xxx1 1100 0000 010xb
-1	1F_F0h	xxx1 1111 1111 000xb
-0.75	1F_F4h	xxx1 1111 1111 010xb
-0.5	1F_F8h	xxx1 1111 1111 100xb
-0.25	1F_FCh	xxx1 1111 1111 110xb
-0.125	1F_FEh	xxx1 1111 1111 111xb
0	00_00h	xxx0 0000 0000 000xb
0.125	00_02h	xxx0 0000 0000 001xb
0.25	00_04h	xxx0 0000 0000 010xb

Table 4.1 Temperature Data Format (continued)

TEMPERATURE (C)	DATA	
	HEX	BINARY
0.5	00_08h	xxx0 0000 0000 100xb
0.75	00_0Ch	xxx0 0000 0000 110xb
1	00_10h	xxx0 0000 0001 000xb
64	04_00h	xxx0 0100 0000 000xb
128	08_00h	xxx0 1000 0000 000xb
191	0B_F0h	xxx0 1011 1111 000xb
$\geq 191.875$	0B_FEh	xxx0 1011 1111 111xb

## Datasheet

## Chapter 5 Temperature Registers

The EMC1501 contains two independent register sets: Temperature and EEPROM Data Set. The Temperature Register Set is accessed via SMBus address 0011\_000xb through 0011\_111xb.

The Temperature Register Set stores the temperature data, limits, and configuration registers. All registers are 16-bit wide with the address pointing to the high byte. In order to read or write from the entire register, the block read and write commands must be used.

All other registers are 8-bits wide.

**Table 5.1 Temperature Register Set**

ADDR	R/W	NAME	FUNCTION	DEFAULT	PAGE
00h	R	Capabilities	Indicate the functions and capabilities of the temperature sensor	00_17h	pg 23
01h	R/W	Configuration	Controls the operation of the temperature monitor	00_00h	pg 25
02h	R/W	High Limit	Sets the High Limit	05_50h	pg 26
03h	R/W	Low Limit	Sets the Low Limit	00_00h	pg 27
04h	R/W	TCRIT Limit	Sets the critical temperature limit	05_A0h	pg 27
05h	R	Temperature Data	Stores the measured internal temperature	N/A	pg 27
06h	R	Manufacturer ID	Stores the pci-sig manufacturer ID	10_55h	pg 28
07h	R	Device / Revision ID	Stores the device ID and revision number of the device	08_42h	pg 28
09h	R/W	MCHP Configuration	Controls MCHP specific configuration bits	00_00h	pg 28
10h	W	One-Shot	Initiates an update of the temperature data when the device is in low power mode	00h	pg 29

### 5.1 Capabilities Register

**Table 5.2 Capabilities Register**

ADDR	R/W	NAME	B15 / B7	B14 / B6	B13 / B5	B12 / B4	B11 / B3	B10 / B2	B9 / B1	B8 / B0	DEFAULT
00h	R	Capabilities	RFU	RFU	RFU	RFU	RFU	RFU	RFU	RFU	00_57h
			EVSD	TMOUT	0	TRES[1:0]	RANGE	ACC	EVENT		

The Capabilities Register indicates the capabilities of the temperature sensor.

Bits 15 - Bit 8 - RFU - Reserved for future use. These bits will always read '0' and writing to them will have no effect.

Bit 7 - EVSD - Indicates the behavior of the EVENT pin when the device is in Shutdown.

- '0' (default) - The EVENT pin retains its previous state when the device enters the Shutdown mode. It will remain in its previous state until the next temperature sample is measured at which point it will return to normal operation as determined by its operating mode and the measured temperature.
- '1' - The EVENT pin is deasserted when the device enters Shutdown. It will remain deasserted until the next temperature sample is measured at which point it will return to normal operation as determined by its operating mode and the measured temperature.

Bit 6 - TMOUT - Indicates the SMBus / I<sup>2</sup>C timeout behavior supported. Timeout is supported in all modes of operation and for all modes of access (Temperature, EEPROM, or Locking).

- '0' - The timeout time varies from 10ms to 60ms.
- '1' (default) - The timeout time varies from 25ms to 35ms (SMBus compatible).

Bit 5 - '0' - This bit will return a logic '0'.

Bits 4 - 3 - TRES[1:0] - Indicates the resolution of the temperature monitor as shown in [Table 5.3](#).

**Table 5.3 TRES Bit Decode**

TRES[1:0]		TEMPERATURE RESOLUTION
1	0	
0	0	0.5°C (9-bit)
0	1	0.25°C (10-bit)
1	0	0.125°C (11-bit) (default)
1	1	0.0625°C (12-bit)

Bit 2 - RANGE - Indicates the supported temperature range.

- '0' - The temperature monitor clamps values lower than 0°C.
- '1' (default) - The temperature monitor can read temperatures below 0°C and sets the sign bit appropriately.

Bit 1 - ACC - Indicates the supported temperature accuracy.

- '0' - The temperature monitor has  $\pm 2^\circ\text{C}$  accuracy of the active range (25°C to 100°C) and 3°C accuracy over the entire operating range.
- '1' (default) - The temperature monitor has  $\pm 1^\circ\text{C}$  accuracy over the active range (25°C to 100°C) and 2°C accuracy over the entire operating range.

Bit 0 - EVENT - Indicates whether the temperature monitor supports interrupt capabilities.

- '0' - The device does not support interrupt capabilities.
- '1' (default) - The device supports interrupt capabilities.



## 5.2 Configuration Register

**Table 5.4 Configuration Register**

ADDR	R/W	NAME	B15 / B7	B14 / B6	B13 / B5	B12 / B4	B11 / B3	B10 / B2	B9 / B1	B8 / B0	DEFAULT
01h	R/W	Configuration	RFU	RFU	RFU	RFU	RFU	HYST[1:0]		SHDN	00_00h
			TCRIT_LOCK	LIMIT_LOCK	CLEAR	EVENT_STS	EVENT_CTRL	TCRIT_ONLY	EVENT_POL	EVENT_MODE	

The Configuration Register holds the control and status bits of the EVENT pin as well as general hysteresis on all limits.

Bits 15 - 11 - RFU - Reserved for future use. These bits will always read '0' and writing to them will have no effect.

Bits 10 - 9 - HYST[1:0] - Control the hysteresis that is applied to all temperature limits as shown in Table 5.5. This hysteresis applies to the High and Tcrit temperature limits when the temperature is dropping below the threshold. Once the temperature is above the threshold, it must drop below the threshold minus the hysteresis in order to be flagged as an interrupt event.

The hysteresis applies to the low temperature limit so that the temperature must drop below the limit minus the hysteresis value before an interrupt event is flagged (and rise above the limit without the hysteresis).

The HYST[1:0] bits are locked if the TCRIT\_LOCK bit has been set.

**Table 5.5 HYST Bit Decode**

HYST[1:0]		HYSTERESIS
1	0	
0	0	disable hysteresis (default)
0	1	1.5°C
1	0	3°C
1	1	6°C

Bit 8 - SHDN - Controls the power state of the temperature monitor. If either of the lock bits are set (bit 7 and bit 6), this bit cannot be set until they are unlocked. It can be cleared at any time.

- '0' (default) - The temperature monitor is active and converting.
- '1' - The temperature monitor is disabled and will not generate interrupts or update the temperature data.

Bit 7 - TCRIT\_LOCK - Locks the TCRIT Limit Register from being updated.

- '0' (default) - The TCRIT Limit Register can be updated normally.
- '1' - The TCRIT Limit Register is locked and cannot be updated. Once this bit has been set, it cannot be cleared until an internal power on reset. The HYST[1:0] bits are likewise locked and cannot be updated.

Bit 6 - LIMIT\_LOCK - Locks the High and Low Limit Registers from being updated.

- '0' (default) - The High and Low Limit Registers can be updated normally.

- '1' - The High and Low Limit Registers are locked and cannot be updated. Once this bit has been set, it cannot be cleared until an internal power on reset.

Bit 5 - CLEAR - Clears the EVENT pin when it has been asserted. This bit is write only and will always read '0'.

- '0' - does nothing.
- '1' - The EVENT pin is released and will not be asserted until a new interrupt condition occurs. This bit is ignored if the device is operating in Comparator Mode (including with TCRIT limits which always operate in comparator mode). This bit is self clearing.

Bit 4 - EVENT\_STS - Indicates if the EVENT pin is asserted. This bit is read only.

- '0' (default) - The EVENT pin is not asserted.
- '1' - The EVENT pin is being asserted by the device.

Bit 3 - EVENT\_CTRL - Masks the EVENT pin from generating an interrupt. If either of the lock bits are set (bit 7 and bit 6), this bit cannot be altered.

- '0' (default) - The EVENT pin is disabled and will not generate interrupts.
- '1' - The EVENT pin is enabled.

Bit 2 - TCRIT\_ONLY - Controls whether the EVENT pin will be asserted from a high / low out-of-limit condition. When the LIMIT\_LOCK bit is set, this bit cannot be altered.

- '0' (default) - The EVENT pin will be asserted if the measured temperature is above the High Limit or below the Low Limit in addition to if the temperature is above the TCRIT Limit.
- '1' - The EVENT pin will only be asserted if the measured temperature is above the TCRIT Limit.

Bit 1 - EVENT\_POL - Controls the "active" state of the EVENT pin. The EVENT pin is driven (or allowed to be pulled) to this state when it is asserted. If either of the lock bits are set (bit 7 and bit 6), this bit cannot be altered.

- '0' (default) - The EVENT pin is active low. The "active" state of the pin will be logical '0' and will use a pull-up resistor to set the inactive state.
- '1' - The EVENT pin is active high. The "active" state of the pin will be logical '1'. The device will release the pin and allow an external pull-up resistor to drive the active state. When in the inactive state, the pin will actively pull the pin low.

Bit 0 - EVENT\_MODE - Determines the interrupt mode of operation (see [Section 4.2.1](#)) when the temperature exceeds the high limit or drops below the low limit. The EVENT pin will always operate in Comparator mode if the temperature meets or exceeds the TCRIT limit. If either of the lock bits are set (bit 7 and bit 6), this bit cannot be altered.

- '0' (default) - the EVENT pin operates in Comparator mode.
- '1' - The EVENT output pin operates in Interrupt mode.

## 5.3 High Limit Register

Table 5.6 High Limit Register

ADDR	R/W	NAME	B15 / B7	B14 / B6	B13 / B5	B12 / B4	B11 / B3	B10 / B2	B9 / B1	B8 / B0	DEFAULT
02h	R/W	High Limit	-	-	-	Sign	128	64	32	16	05_50h (85°C)
			8	4	2	1	0.5	0.25	-	-	

The High Limit Register holds the High Limit for the nominal operating window. When the temperature rises above the High Limit, or drops below or equal to the High Limit minus the hysteresis, the EVENT

## Datasheet

pin is asserted (if enabled). If the LIMIT\_LOCK bit is set in the Configuration Register (see [Section 5.2](#)), this register becomes read-only.

When the limit is changed, the temperature is compared to the new limit on the next update cycle.

## 5.4 Low Limit Register

Table 5.7 Low Limit Register

ADDR	R/W	NAME	B15 / B7	B14 / B6	B13 / B5	B12 / B4	B11 / B3	B10 / B2	B9 / B1	B8 / B0	DEFAULT
03h	R/W	Low Limit	-	-	-	Sign	128	64	32	16	00_00h (0°C)
			8	4	2	1	0.5	0.25	-	-	

The Low Limit Register holds the lower limit for the nominal operating window. When the temperature drops below the Low Limit minus the hysteresis or rises up to meet or exceed the Low Limit, the EVENT pin is asserted (if enabled). If the LIMIT\_LOCK bit is set in the Configuration Register (see [Section 5.2](#)), this register becomes read-only.

When the limit is changed, the temperature is compared to the new limit on the next update cycle.

## 5.5 TCRT Limit Register

Table 5.8 TCRT Limit Register

ADDR	R/W	NAME	B15 / B7	B14 / B6	B13 / B5	B12 / B4	B11 / B3	B10 / B2	B9 / B1	B8 / B0	DEFAULT
04h	R/W	TCRT Limit	-	-	-	Sign	128	64	32	16	05_A0h (90°C)
			8	4	2	1	0.5	0.25	-	-	

The TCRT Limit Register holds the TCRT Limit. If the temperature exceeds the limit, the EVENT pin will be asserted. It will remain asserted until the temperature drops below or equal to the limit minus hysteresis. If the TCRT\_LOCK bit is set in the Configuration Register (see [Section 5.2](#)), this register becomes read-only.

When the limit is changed, the temperature is compared to the new limit on the next update cycle.

## 5.6 Temperature Data Register

Table 5.9 Temperature Data Register

ADDR	R/W	NAME	B15 / B7	B14 / B6	B13 / B5	B12 / B4	B11 / B3	B10 / B2	B9 / B1	B8 / B0	DEFAULT
05h	R	Temp Data	TCRT	HIGH	LOW	Sign	128	64	32	16	N/A (00_00h)
			8	4	2	1	0.5	0.25	0.125	-	

The Temperature Data Register holds the 11-bit + sign data for the internal temperature measurement as well as the status bits indicating which error conditions, if any, are active.

Bit 15 - TCRIT - When set, the temperature is above the TCRIT Limit. This bit will remain set so long as the temperature is above TCRIT and will automatically clear once the temperature has dropped below or equal to the limit minus the hysteresis.

Bit 14 - HIGH - When set, the temperature is above the High Limit. This bit will remain set so long as the temperature is above the HIGH limit. Once set, it will only be cleared when the temperature drops below the HIGH Limit or equal to minus the hysteresis.

Bit 13 - LOW - When set, the temperature is below the Low Limit. This bit will remain set so long as the temperature is below the Low Limit minus the hysteresis. Once set, it will only be cleared when the temperature meets or exceeds the Low Limit.

## 5.7 Manufacturer ID Register

Table 5.10 Manufacturer ID Register

ADDR	R/W	NAME	B15 / B7	B14 / B6	B13 / B5	B12 / B4	B11 / B3	B10 / B2	B9 / B1	B8 / B0	DEFAULT
06h	R/W	Manufacturer ID	0	0	0	1	0	0	0	0	10_55h
			0	1	0	1	0	1	0	1	

The Manufacturer ID Register holds the PCI SIG number assigned to Microchip.

## 5.8 Device ID / Revision Register

Table 5.11 Device ID / Revision Register

ADDR	R/W	NAME	B15 / B7	B14 / B6	B13 / B5	B12 / B4	B11 / B3	B10 / B2	B9 / B1	B8 / B0	DEFAULT
07h	R	Device ID	0	0	0	0	1	0	0	0	08_42h
		Revision	0	1	0	0	0	0	1	0	

The upper byte of the Device ID / Revision Register stores a unique number distinguishing the EMC1501 from other devices. The lower byte holds the revision value.

## 5.9 MCHP Configuration Register

Table 5.12 MCHP Configuration Register

ADDR	R/W	NAME	B15 / B7	B14 / B6	B13 / B5	B12 / B4	B11 / B3	B10 / B2	B9 / B1	B8 / B0	DEFAULT
09h	R/W	MCHP Configuration	TIME OUT	PULL DOWN_OVR	-	-	-	-	-	-	00h
			-	-	-	-	-	-	-	-	00h

The MCHP Configuration register controls timeout functionality as well controls to disable the internal pulldown devices on the SA1 and SA2 pins. The pulldown device on the SA0 pin cannot be disabled.

**Datasheet**

Bit 15 - TIMEOUT - Enables the SMBus timeout function (see [Section 3.1.7](#)).

- '0' (default) - The SMBus timeout function is disabled. The bus will not timeout and is fully I<sup>2</sup>C compatible.
- '1' - The SMBus timeout function is enabled. If the SDA pin is held low for longer than 30ms while the SCL pin is sending clocks, the bus will timeout and the SMBus interface will reset.

Bit 14 - PULLDOWN\_OVR - Overrides internal pull-down devices on the SA1 and SA2 pins.

- '0' (default) - The pull-down devices on the SA1 and SA2 pins are enabled and will pull the corresponding pin low if left floating.
- '1' - The pull-down devices on the SA1 and SA2 pins are disabled.

## 5.10 One-Shot Register

**Table 5.13 One-Shot Register**

ADDR	R/W	NAME	B15 / B7	B14 / B6	B13 / B5	B12 / B4	B11 / B3	B10 / B2	B9 / B1	B8 / B0	DEFAULT
10h	W	One-Shot	-	-	-	-	-	-	-	-	00h
			-	-	-	-	-	-	-	-	00h

The One-Shot register is used to initiate a single temperature reading while the temperature monitor portion of the EMC1501 is disabled. Writing to this register while the SHDN bit is set to a logic '1' will cause the device to immediately measure the temperature and compare the measured temperature against all limits. The data written to the register is not important and will not be stored.

Writing to this register while the SHDN bit is set to a logic '0' will have no effect.

Bit 11- COMP\_INT\_BEH - Determines the behavior of the EVENT pin when the EVENT mode is switched from Comparator Mode to Interrupt Mode while the temperature is above the high limit or below the low limit.

- '0' - When the EVENT Pin operating mode is changed from Comparator Mode to Interrupt Mode, the EVENT pin will be released based on the CLEAR bit being set (or having been set).
- '1' - When the EVENT Pin operating mode is changed from Comparator Mode to Interrupt Mode, the EVENT pin will be released automatically regardless of the CLEAR bit.

## Chapter 6 EEPROM Data Set Registers

The EMC1501 contains two independent register sets: Temperature and EEPROM Data Set. The EEPROM Data Set Registers are accessed via SMBus address 1010\_000xb through 1010\_111xb (set by the SA2, SA1, and SA0 pins).

### 6.1 EEPROM Data Set Registers

The EEPROM Data Set registers contain 256 general 8-bit read / write registers for any function. The lower 128 bytes are subject to locking mechanisms as described in [Section 4.5](#); however, the upper 128 bytes are always available.

The unprogrammed value of all EEPROM registers will be FFh.

#### 6.1.1 Example SPD Register Allocation

[Table 6.1](#) shows the register map allocation that is prescribed for use in defining a memory module SPD per JEDEC specification 21-C. This is a generic map and is not indicative of any particular memory module or manufacturer. This is one example of the usage for the EEPROM register space.

**Table 6.1 EEPROM Data Set Registers**

ADDR	R/W	NAME	FUNCTION	DEFAULT	LOCK
00h	R/W	SPD Size	Indicates the number of bytes used by the Serial Presence Detect (SPD) Look-Up Table (LUT)	FFh	PSW, SW
01h	R	Total SPD Size	Indicates the number of bytes available in the SPD EEPROM Data Set	FFh	PSW, SW
02h	R/W	Memory Type	Identifies the fundamental memory type used in the Memory Module	FFh	PSW, SW
03h - 1Fh	R/W	Memory Specific Descriptions	These registers hold memory type specific information related to the fundamental memory type defined in 02h.	FFh	PSW, SW
20h	R/W	Superset Memory Type (optional)	Indicates the superset memory type used in the Memory Module if applicable	FFh	PSW, SW
21h - 3Dh	R/W	Superset Memory Specific Description (optional)	These registers hold superset memory specific information related to the superset memory type defined in 20h.	FFh	PSW, SW
3Eh	R/W	SPD Data Revision Number	Stores the Serial Presence Detect data revision number	FFh	PSW, SW
3Fh	R	Checksum	Stores the checksum of bytes 00h through 3Eh	FFh	PSW, SW
40h - 47h	R/W	Manufacturer Code (optional)	These registers store the Memory Module manufacturer JEDEC ID Code per EIA/JEP106	FFh	PSW, SW
48h	R/W	Manufacturer Location (optional)	Stores a code representing the Memory Module manufacturer location	FFh	PSW, SW

## Datasheet

Table 6.1 EEPROM Data Set Registers (continued)

ADDR	R/W	NAME	FUNCTION	DEFAULT	LOCK
49h - 5Ah	R/W	Manufacturer Part Number (optional)	These registers store the Memory Module manufacturer part number in ASCII format	FFh	PSW, SW
5Bh - 5Ch	R/W	Module Revision Code (optional)	These registers store the Memory Module revision code	FFh	PSW, SW
5Dh	R/W	Module Year (optional)	Stores the last 2-digits of the year that the Memory Module was manufactured in BCD	FFh	PSW, SW
5Eh	R/W	Module Month (optional)	Stores the month that the Memory Module was manufactured in BCD	FFh	PSW, SW
5Fh - 62h	R/W	Module Serial Number (optional)	These registers store the serial number for the Memory Module	FFh	PSW, SW
63h - 7Dh	R/W	Manufacturer Specific Data (optional)	These registers store manufacturer specific data useful to the Memory Module	FFh	PSW, SW
7Eh	R	Reserved	This register cannot be modified	FFh	PSW, SW
7Fh	R	Reserved	This register cannot be modified	FFh	PSW, SW
80h - FFH	R/W	Open	These registers can be used for any purpose	FFh	n/a

### 6.1.2 Register Data

The Memory Module manufacturer is responsible for inputting all the pertinent Serial Presence Detection data into the appropriate registers as described in [Table 6.1](#) and JEDEC Standard No 21-C Serial Presence Detection.

## 6.2 Lock Description

The Lock column describes the protection mechanisms available for data in the specific register spaces.

PSW means that these data bytes will be permanently locked if the Protection Register is written via SMBus address 0110\_000b through 0110\_111b.

SW means that these data bytes can be locked via the SWP command and unlocked using the CWP command.

# Chapter 7 Package Information

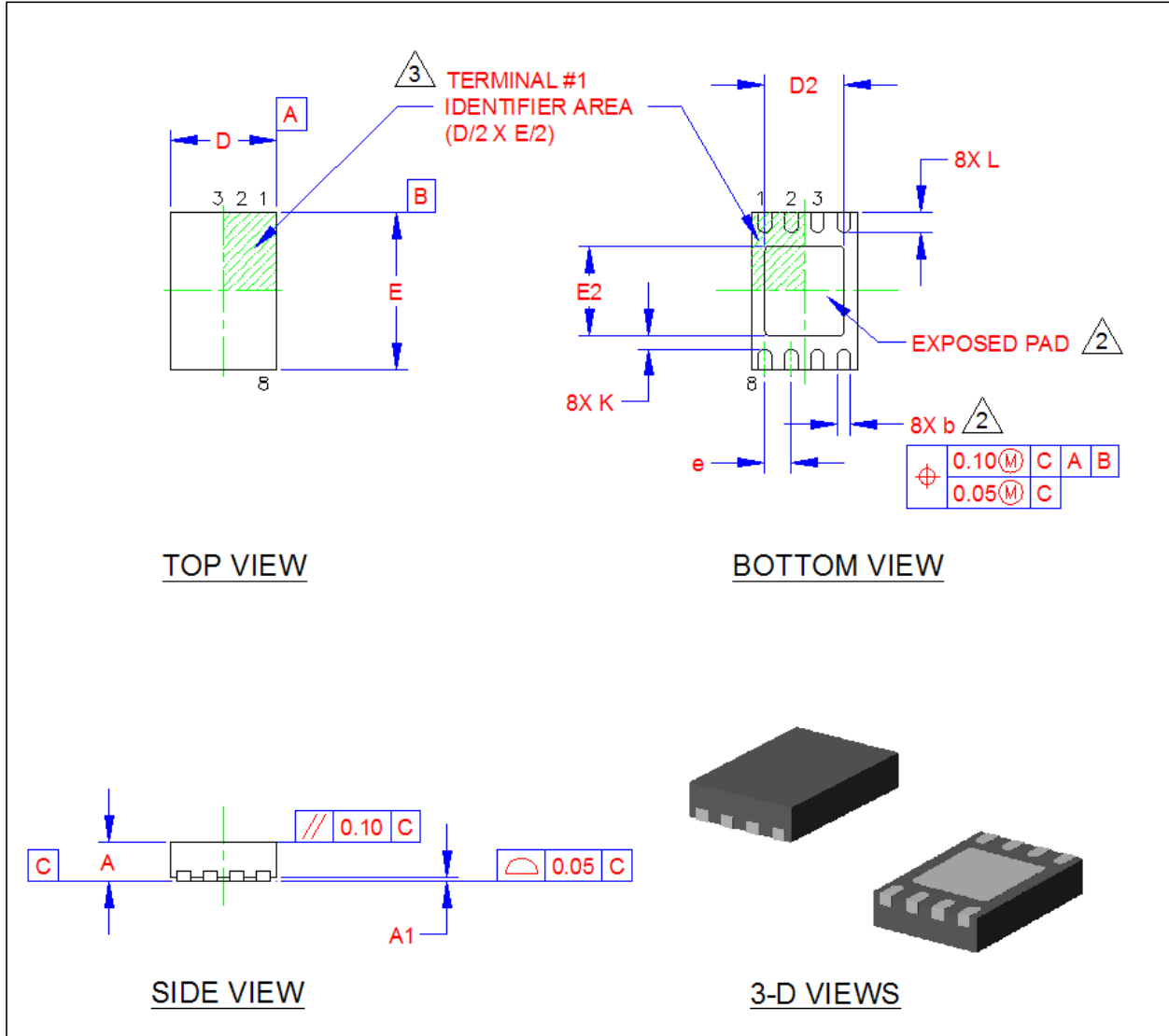

Figure 7.1 2mm x 3mm TDFN-8 Package Drawing



Datasheet

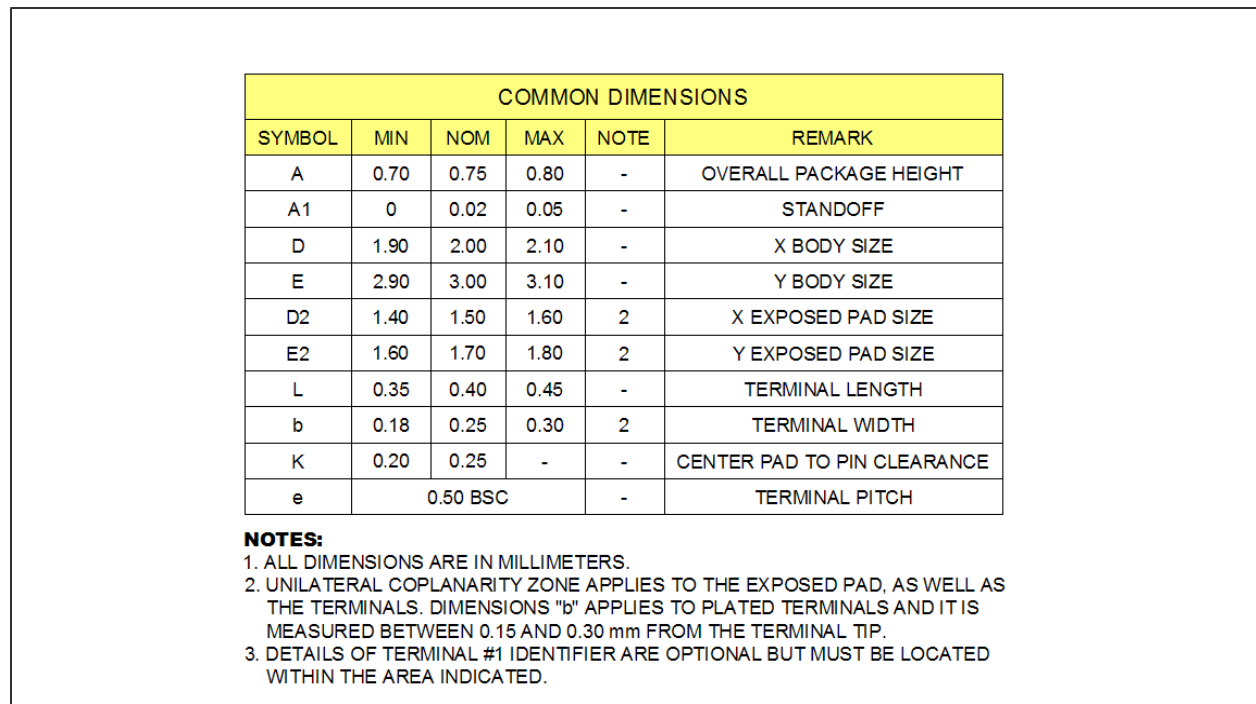

Figure 7.2 2mm x 3mm TDFN-8 Package Dimensions

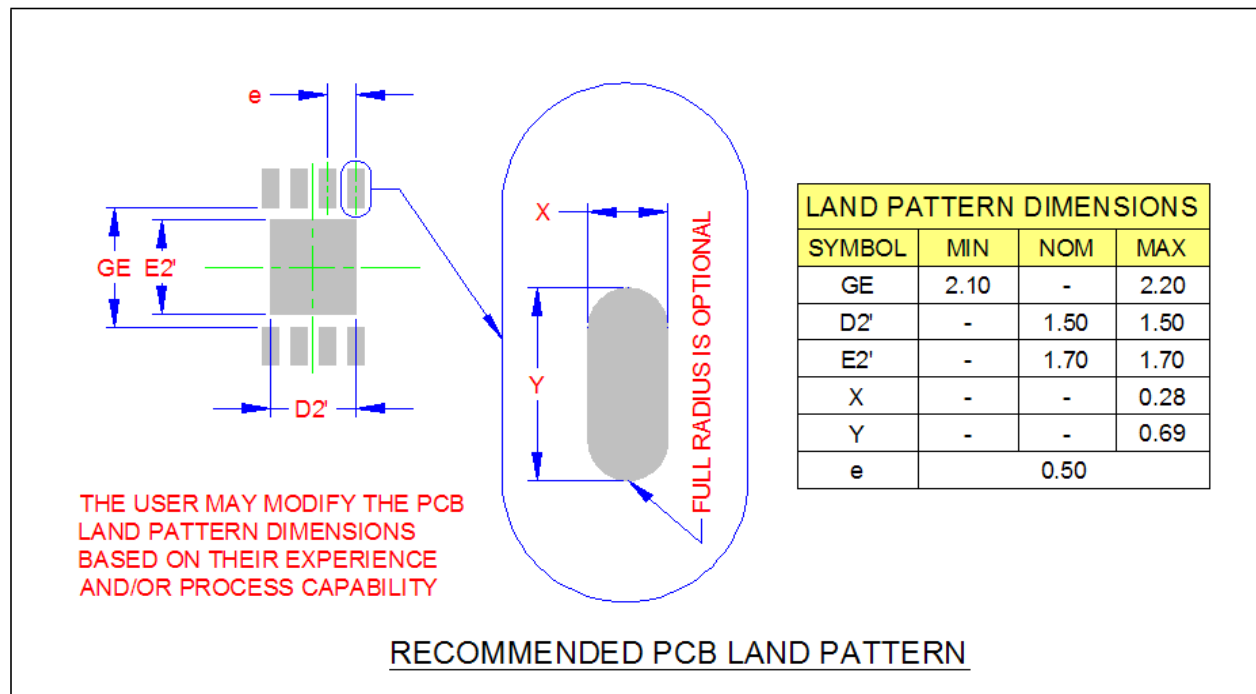

Figure 7.3 2mm x 3mm TDFN PCB Layout

## 7.1 Package Marking

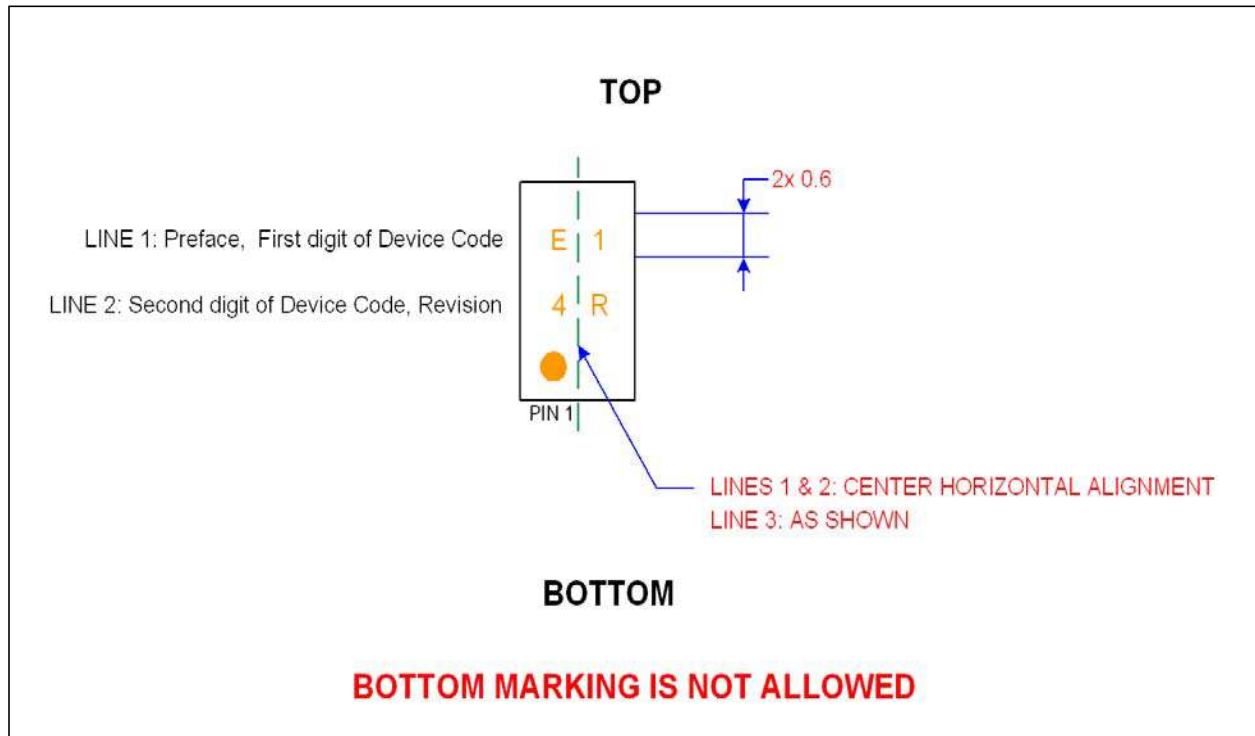

Figure 7.4 Package Marking

## Chapter 8 Datasheet Revision History

**Table 8.1 Customer Revision History**

REVISION LEVEL & DATE	SECTION/FIGURE/ENTRY	CORRECTION
REV A	Replaces the previous SMSC version Rev. 0.93	
Rev. 1.0 (09-03-09)	Ordering Information	Reel size changed from 4,000 pieces to 5,000.
	Table 2.2, "Electrical Specifications"	"VDD = 1.7V TO 1.9V, 2.3V TO 2.7V, 3.0V TO 3.6V" changed to "VDD =1.7V to 3.6V"  Updated electrical specs for EEPROM access current. Updated internal temperature accuracy range (active range) for +/- 1°C from 70-100°C to 25-100°C.
	Ordering information; Table 2.1, "Absolute Maximum Ratings"; Figure 7.1, "2mm x 3mm TDFN-8 Package Drawing"; Figure 7.2, "2mm x 3mm TDFN-8 Package Dimensions" and Figure 7.3, "2mm x 3mm TDFN PCB Layout"	Changed order number from EMC1501-1-ACX-TR to EMC1501-1-AC3-TR; package changed from DFN to TDFN
	Section 5.1, "Capabilities Register"	Updated capabilities register bit settings
	Section 5.8, "Device ID / Revision Register"	Updated rev ID
	Figure 7.4, "Package Marking"	Updated package marking; diagram modified changing "device ID" to "device code"
Rev. 0.8 (05-14-09)	Table 2.1, "Absolute Maximum Ratings"	Thermal Resistance rating changed from "41" to "89".
	Chapter 6, EEPROM Data Set Registers	Modified from: "The EMC1501 contains multiple independent register sets..."  to: "The EMC1501 contains two independent register sets..."
Rev 0.8 (05-12-09)	Figure 1.1, "Pin Diagram"	Updated figure
	Section Table 3.9, "SMBus Addressing" and Section 4.4, "Serial Presence Detection Protection"	Reorganized sections
	Section 4.5.1, "Temperature Limits"	Added application note for hysteresis
	Section 4.2, "EVENT"	Corrected text describing operation
Rev. 0.8 (04-21-09)	Chapter 7, Package Information	Diagrams modified

Table 8.1 Customer Revision History (continued)

REVISION LEVEL & DATE	SECTION/FIGURE/ENTRY	CORRECTION
Rev. 0.8 (03-03-09)	Table 2.2, "Electrical Specifications"	Updated conditions on electrical specifications for standby current
	Section Table 5.4, "Configuration Register"	Updated TCRIT bit to apply to Hystersis
	Section 5.8, "Device ID / Revision Register"	Updated revision number
Rev. 0.72 (10-29-08)	Section 3.2, "Communications Protocols"	Added reference to SMBus Word Read and Word Write Protocols
	Table 6.1, "EEPROM Data Set Registers"	Updated text to indicate that EEPROM Data registers are generic. Rearranged sections and text to indicate that table is an example for SPD functions only
	Figure 7.3, "2mm x 3mm TDFN PCB Layout"	Added PCB Layout figure
Rev. 0.71 (12-12-08)	Initial Release	

---

---

**Note the following details of the code protection feature on Microchip devices:**

- Microchip products meet the specification contained in their particular Microchip Data Sheet.
- Microchip believes that its family of products is one of the most secure families of its kind on the market today, when used in the intended manner and under normal conditions.
- There are dishonest and possibly illegal methods used to breach the code protection feature. All of these methods, to our knowledge, require using the Microchip products in a manner outside the operating specifications contained in Microchip's Data Sheets. Most likely, the person doing so is engaged in theft of intellectual property.
- Microchip is willing to work with the customer who is concerned about the integrity of their code.
- Neither Microchip nor any other semiconductor manufacturer can guarantee the security of their code. Code protection does not mean that we are guaranteeing the product as “unbreakable.”

Code protection is constantly evolving. We at Microchip are committed to continuously improving the code protection features of our products. Attempts to break Microchip's code protection feature may be a violation of the Digital Millennium Copyright Act. If such acts allow unauthorized access to your software or other copyrighted work, you may have a right to sue for relief under that Act.

Information contained in this publication regarding device applications and the like is provided only for your convenience and may be superseded by updates. It is your responsibility to ensure that your application meets with your specifications. MICROCHIP MAKES NO REPRESENTATIONS OR WARRANTIES OF ANY KIND WHETHER EXPRESS OR IMPLIED, WRITTEN OR ORAL, STATUTORY OR OTHERWISE, RELATED TO THE INFORMATION, INCLUDING BUT NOT LIMITED TO ITS CONDITION, QUALITY, PERFORMANCE, MERCHANTABILITY OR FITNESS FOR PURPOSE. Microchip disclaims all liability arising from this information and its use. Use of Microchip devices in life support and/or safety applications is entirely at the buyer's risk, and the buyer agrees to defend, indemnify and hold harmless Microchip from any and all damages, claims, suits, or expenses resulting from such use. No licenses are conveyed, implicitly or otherwise, under any Microchip intellectual property rights.

**Trademarks**

The Microchip name and logo, the Microchip logo, dsPIC, FlashFlex, KEELOQ, KEELOQ logo, MPLAB, PIC, PICmicro, PICSTART, PIC<sup>32</sup> logo, rPIC, SST, SST Logo, SuperFlash and UNI/O are registered trademarks of Microchip Technology Incorporated in the U.S.A. and other countries.

FilterLab, Hampshire, HI-TECH C, Linear Active Thermistor, MTP, SEEVAL and The Embedded Control Solutions Company are registered trademarks of Microchip Technology Incorporated in the U.S.A.

Silicon Storage Technology is a registered trademark of Microchip Technology Inc. in other countries.

Analog-for-the-Digital Age, Application Maestro, BodyCom, chipKIT, chipKIT logo, CodeGuard, dsPICDEM, dsPICDEM.net, dsPICworks, dsSPEAK, ECAN, ECONOMONITOR, FanSense, HI-TIDE, In-Circuit Serial Programming, ICSP, Mindi, MiWi, MPASM, MPF, MPLAB Certified logo, MPLIB, MPLINK, mTouch, Omniscient Code Generation, PICC, PICC-18, PICDEM, PICDEM.net, PICKit, PICtail, REAL ICE, rFLAB, Select Mode, SQI, Serial Quad I/O, Total Endurance, TSHARC, UniWinDriver, WiperLock, ZENA and Z-Scale are trademarks of Microchip Technology Incorporated in the U.S.A. and other countries.

SQTP is a service mark of Microchip Technology Incorporated in the U.S.A.

GestIC and ULPP are registered trademarks of Microchip Technology Germany II GmbH & Co. KG, a subsidiary of Microchip Technology Inc., in other countries.

A more complete list of registered trademarks and common law trademarks owned by Standard Microsystems Corporation (“SMSC”) is available at: [www.smsc.com](http://www.smsc.com). The absence of a trademark (name, logo, etc.) from the list does not constitute a waiver of any intellectual property rights that SMSC has established in any of its trademarks.

All other trademarks mentioned herein are property of their respective companies.

© 2013, Microchip Technology Incorporated, Printed in the U.S.A., All Rights Reserved.

ISBN: 9781620776810

**QUALITY MANAGEMENT SYSTEM**  
**CERTIFIED BY DNV**  
**== ISO/TS 16949 ==**

*Microchip received ISO/TS-16949:2009 certification for its worldwide headquarters, design and wafer fabrication facilities in Chandler and Tempe, Arizona; Gresham, Oregon and design centers in California and India. The Company's quality system processes and procedures are for its PIC® MCUs and dsPIC® DSCs, KEELOQ® code hopping devices, Serial EEPROMs, microperipherals, nonvolatile memory and analog products. In addition, Microchip's quality system for the design and manufacture of development systems is ISO 9001:2000 certified.*



# MICROCHIP

## Worldwide Sales and Service

### AMERICAS

**Corporate Office**  
2355 West Chandler Blvd.  
Chandler, AZ 85224-6199  
Tel: 480-792-7200  
Fax: 480-792-7277  
Technical Support:  
<http://www.microchip.com/support>  
Web Address:  
[www.microchip.com](http://www.microchip.com)

**Atlanta**  
Duluth, GA  
Tel: 678-957-9614  
Fax: 678-957-1455

**Austin, TX**  
Tel: 512-257-3370

**Boston**  
Westborough, MA  
Tel: 774-760-0087  
Fax: 774-760-0088

**Chicago**  
Itasca, IL  
Tel: 630-285-0071  
Fax: 630-285-0075

**Cleveland**  
Independence, OH  
Tel: 216-447-0464  
Fax: 216-447-0643

**Dallas**  
Addison, TX  
Tel: 972-818-7423  
Fax: 972-818-2924

**Detroit**  
Novi, MI  
Tel: 248-848-4000

**Houston, TX**  
Tel: 281-894-5983

**Indianapolis**  
Noblesville, IN  
Tel: 317-773-8323  
Fax: 317-773-5453

**Los Angeles**  
Mission Viejo, CA  
Tel: 949-462-9523  
Fax: 949-462-9608

**New York, NY**  
Tel: 631-435-6000

**San Jose, CA**  
Tel: 408-735-9110

**Canada - Toronto**  
Tel: 905-673-0699  
Fax: 905-673-6509

### ASIA/PACIFIC

**Asia Pacific Office**  
Suites 3707-14, 37th Floor  
Tower 6, The Gateway  
Harbour City, Kowloon  
Hong Kong  
Tel: 852-2401-1200  
Fax: 852-2401-3431

**Australia - Sydney**  
Tel: 61-2-9868-6733  
Fax: 61-2-9868-6755

**China - Beijing**  
Tel: 86-10-8569-7000  
Fax: 86-10-8528-2104

**China - Chengdu**  
Tel: 86-28-8665-5511  
Fax: 86-28-8665-7889

**China - Chongqing**  
Tel: 86-23-8980-9588  
Fax: 86-23-8980-9500

**China - Hangzhou**  
Tel: 86-571-2819-3187  
Fax: 86-571-2819-3189

**China - Hong Kong SAR**  
Tel: 852-2943-5100  
Fax: 852-2401-3431

**China - Nanjing**  
Tel: 86-25-8473-2460  
Fax: 86-25-8473-2470

**China - Qingdao**  
Tel: 86-532-8502-7355  
Fax: 86-532-8502-7205

**China - Shanghai**  
Tel: 86-21-5407-5533  
Fax: 86-21-5407-5066

**China - Shenyang**  
Tel: 86-24-2334-2829  
Fax: 86-24-2334-2393

**China - Shenzhen**  
Tel: 86-755-8864-2200  
Fax: 86-755-8203-1760

**China - Wuhan**  
Tel: 86-27-5980-5300  
Fax: 86-27-5980-5118

**China - Xian**  
Tel: 86-29-8833-7252  
Fax: 86-29-8833-7256

**China - Xiamen**  
Tel: 86-592-2388138  
Fax: 86-592-2388130

**China - Zhuhai**  
Tel: 86-756-3210040  
Fax: 86-756-3210049

### ASIA/PACIFIC

**India - Bangalore**  
Tel: 91-80-3090-4444  
Fax: 91-80-3090-4123

**India - New Delhi**  
Tel: 91-11-4160-8631  
Fax: 91-11-4160-8632

**India - Pune**  
Tel: 91-20-3019-1500

**Japan - Osaka**  
Tel: 81-6-6152-7160  
Fax: 81-6-6152-9310

**Japan - Tokyo**  
Tel: 81-3-6880-3770  
Fax: 81-3-6880-3771

**Korea - Daegu**  
Tel: 82-53-744-4301  
Fax: 82-53-744-4302

**Korea - Seoul**  
Tel: 82-2-554-7200  
Fax: 82-2-558-5932 or  
82-2-558-5934

**Malaysia - Kuala Lumpur**  
Tel: 60-3-6201-9857  
Fax: 60-3-6201-9859

**Malaysia - Penang**  
Tel: 60-4-227-8870  
Fax: 60-4-227-4068

**Philippines - Manila**  
Tel: 63-2-634-9065  
Fax: 63-2-634-9069

**Singapore**  
Tel: 65-6334-8870  
Fax: 65-6334-8850

**Taiwan - Hsin Chu**  
Tel: 886-3-5778-366  
Fax: 886-3-5770-955

**Taiwan - Kaohsiung**  
Tel: 886-7-213-7830

**Taiwan - Taipei**  
Tel: 886-2-2508-8600  
Fax: 886-2-2508-0102

**Thailand - Bangkok**  
Tel: 66-2-694-1351  
Fax: 66-2-694-1350

### EUROPE

**Austria - Wels**  
Tel: 43-7242-2244-39  
Fax: 43-7242-2244-393

**Denmark - Copenhagen**  
Tel: 45-4450-2828  
Fax: 45-4485-2829

**France - Paris**  
Tel: 33-1-69-53-63-20  
Fax: 33-1-69-30-90-79

**Germany - Dusseldorf**  
Tel: 49-2129-3766400

**Germany - Munich**  
Tel: 49-89-627-144-0  
Fax: 49-89-627-144-44

**Germany - Pforzheim**  
Tel: 49-7231-424750

**Italy - Milan**  
Tel: 39-0331-742611  
Fax: 39-0331-466781

**Italy - Venice**  
Tel: 39-049-7625286

**Netherlands - Drunen**  
Tel: 31-416-690399  
Fax: 31-416-690340

**Poland - Warsaw**  
Tel: 48-22-3325737

**Spain - Madrid**  
Tel: 34-91-708-08-90  
Fax: 34-91-708-08-91

**Sweden - Stockholm**  
Tel: 46-8-5090-4654

**UK - Wokingham**  
Tel: 44-118-921-5800  
Fax: 44-118-921-5820

10/28/13