

RECOMMENDED P.C.B. LAYOUT

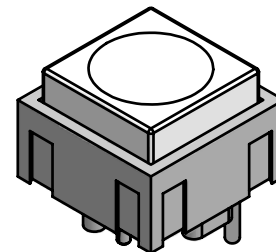

ISOMETRIC

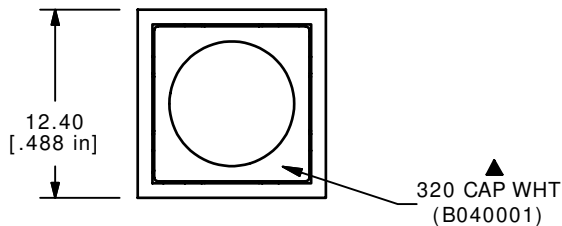
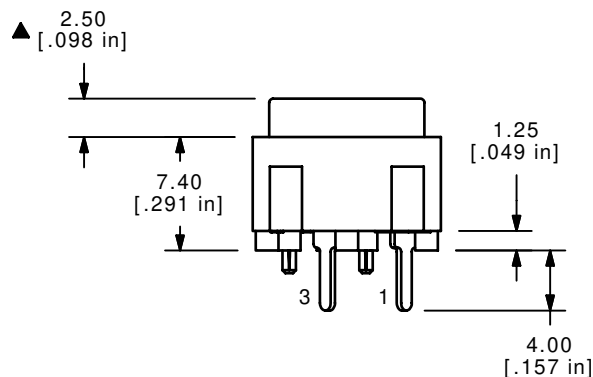
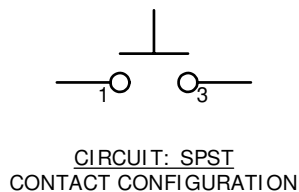

320 E1-1 CONTACT  
(B050001)

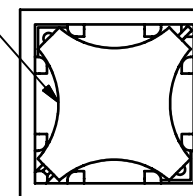

TOP VIEW W/ CAP REMOVED

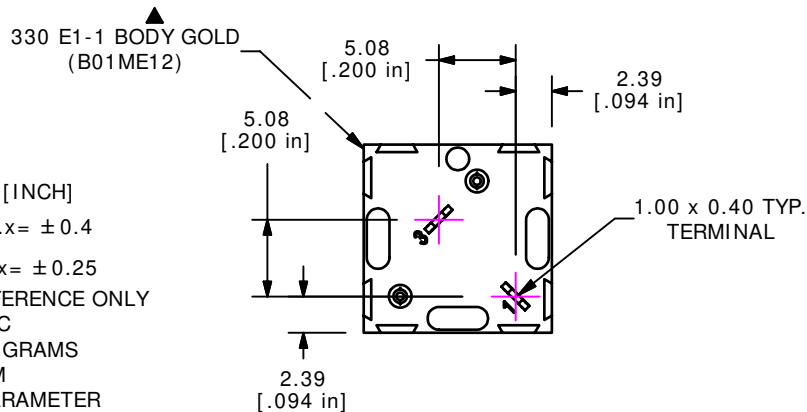

- NOTES:
1. ALL DIMENSIONS IN MM [INCH]
  2. GENERAL TOLERANCE: x.x = ± 0.4  
x.xx = ± 0.25
  3. TERMINAL NO'S FOR REFERENCE ONLY
  4. RATING: 25mA, @ 50VDC
  - ▲ 5. OPERATING FORCE: 120 GRAMS
  6. TRAVEL TO MAKE: 0.7MM
  7. ▲ DENOTES CRITICAL PARAMETER
  8. 2002/95/EC (ROHS) COMPLIANT

**E-SWITCH®**

B	16053	REVISED AND REDRAWN	5/25/06	CT
REV	PCR NO	DESCRIPTION	DATE	BY

TITLE 330E11WHT				
SCALE	DATE	DR	DWG	REV
2:1	1/12/2001	CJB	XB0811A	B

THE INFORMATION CONTAINED IN THIS DOCUMENT IS PROPRIETARY TO E-SWITCH AND IS NOT TO BE COPIED OR TRANSFERRED