

- 1 HOUSING MATERIAL: GLASS-FILLED POLYMER.
- 2 POST MATERIAL: COPPER ALLOY.
- 3 POST FINISH: DIN 41612 CLASS 2 IN CONTACT AREA. TIN PLATE ON POSTS.
- 4 MARKING ON THIS SIDE.
- 5 RECOMMENDED HOLE SIZE FOR MANUAL APPLICATION OF CONNECTOR ONTO PC BOARD.
- 6 PART NUMBER, DATE CODE MARKED THIS APPROXIMATE AREA.

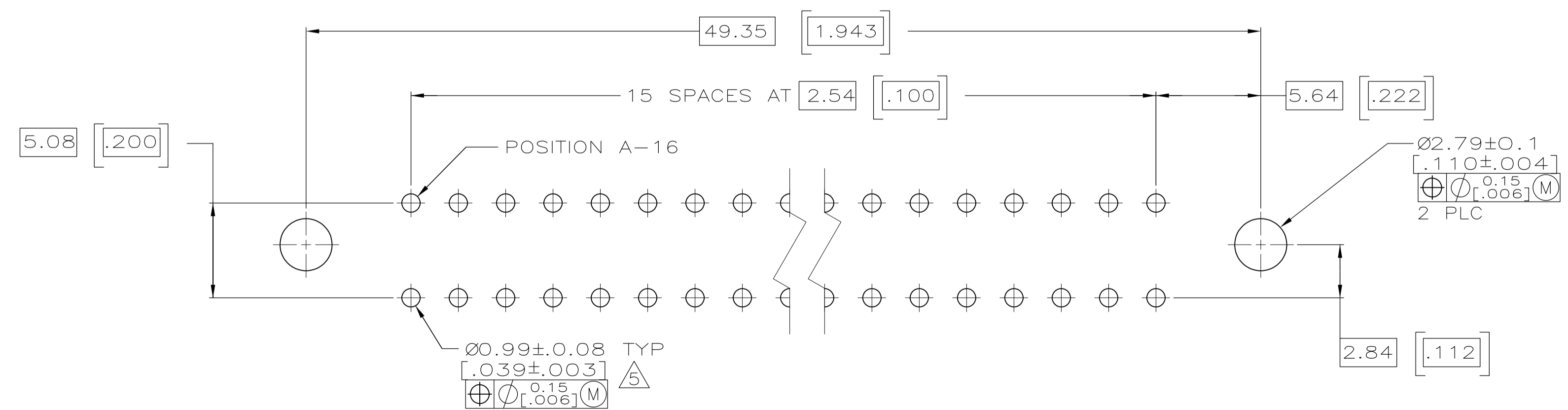
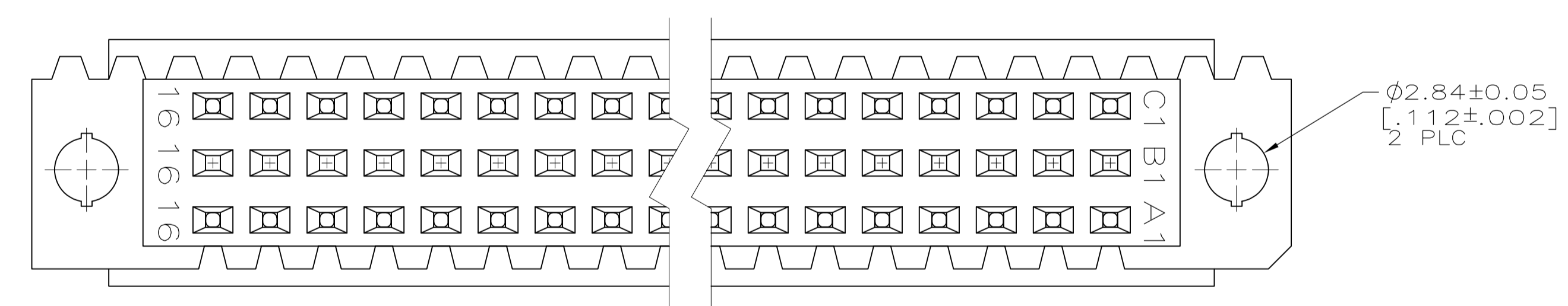
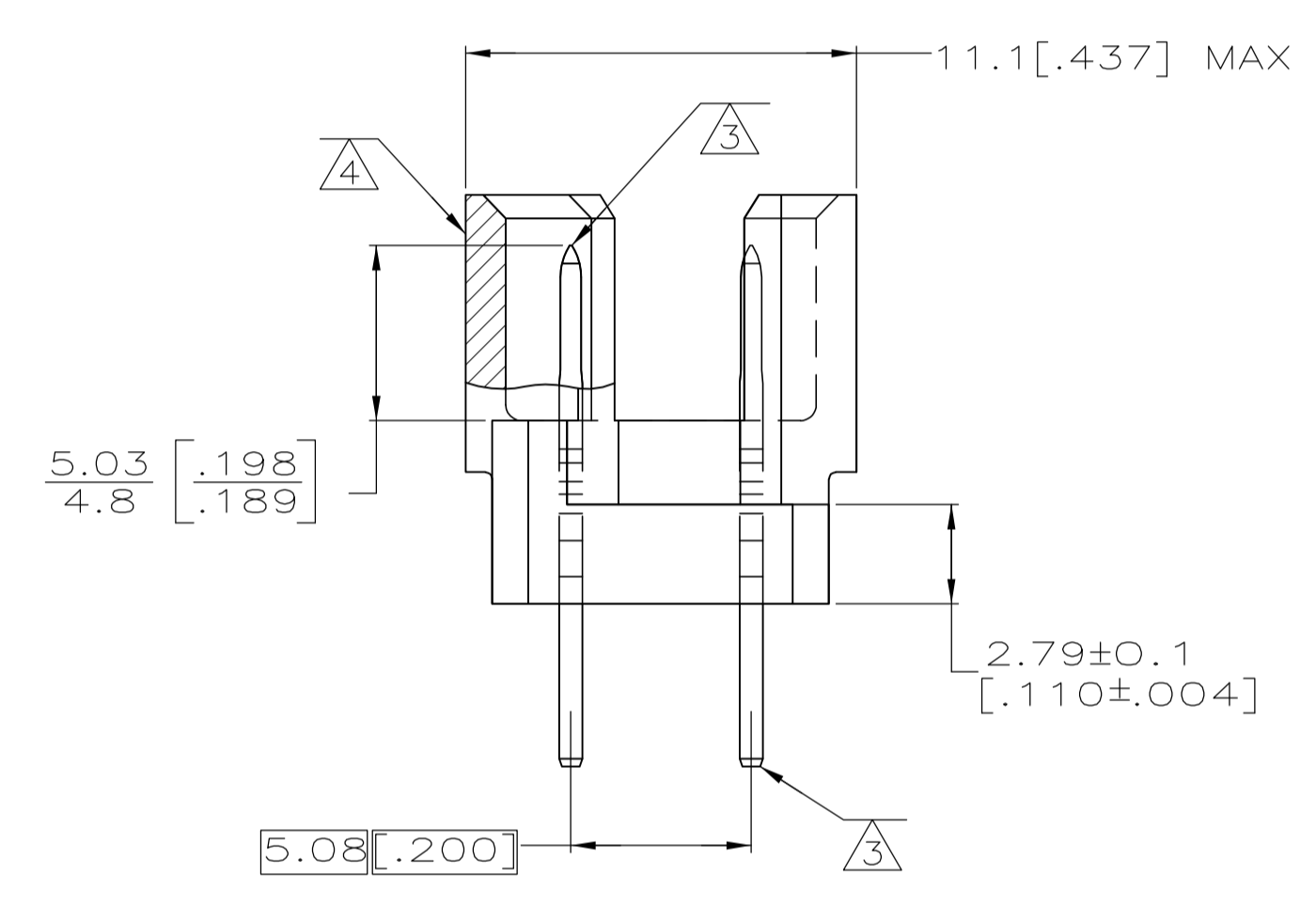
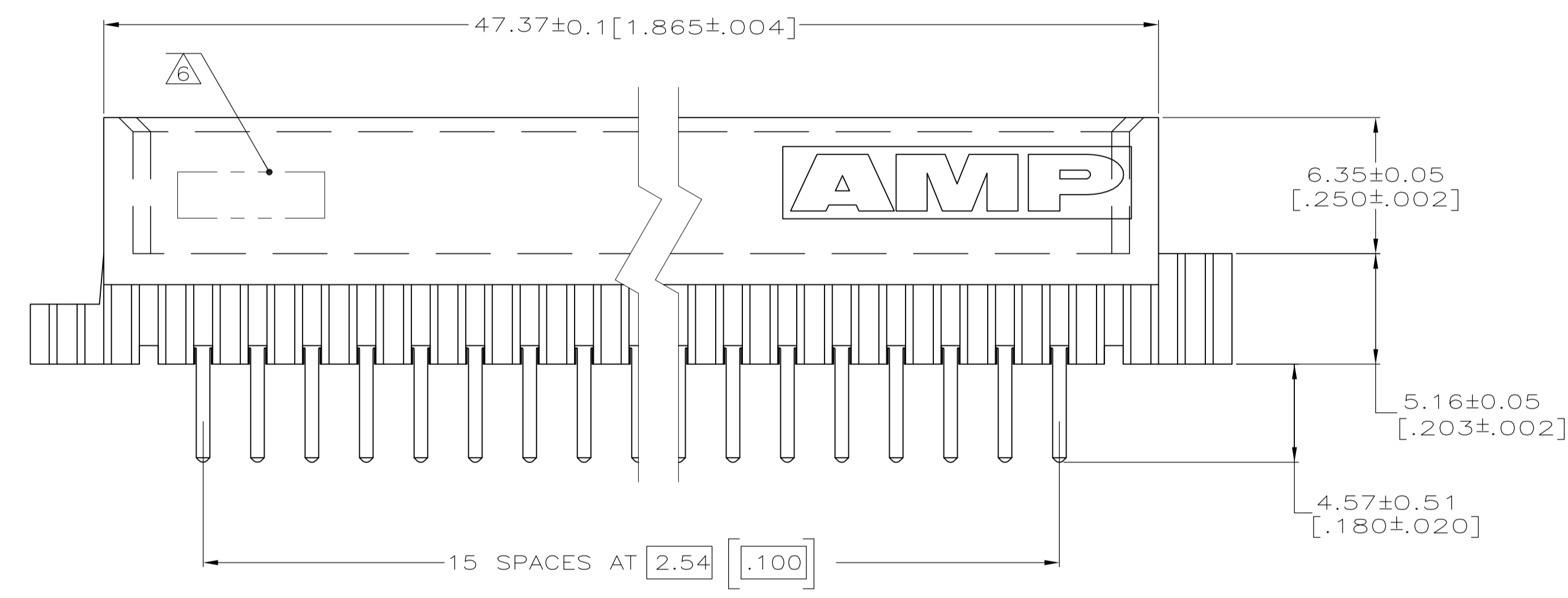
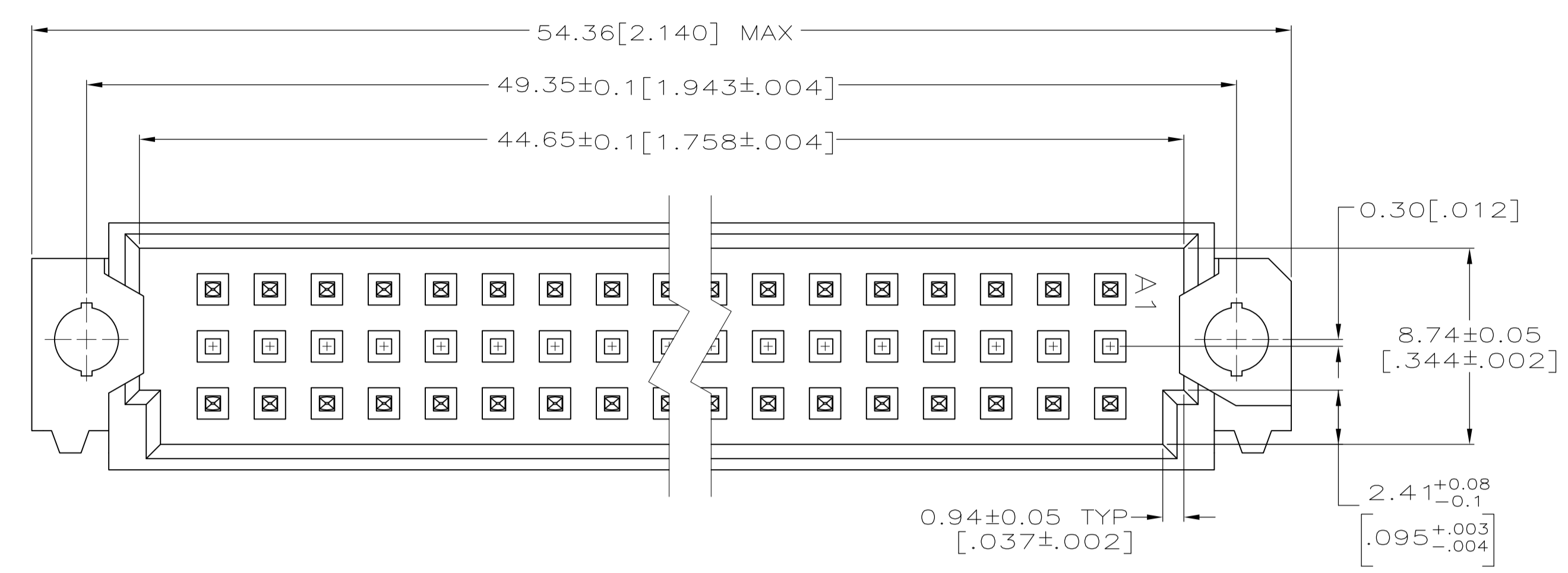

1-16	X	-	X	32	5650936-5
POSITIONS LOADED	C	B	A	NO. OF LOADED POSITION	ASSY PART NUMBER

THIS DRAWING IS A CONTROLLED DOCUMENT.		DIN J. POLIGNONE	OSMAYOS	Tyco Electronics Corporation Harrisburg, PA 17105-3608	
DIMENSIONS: mm [INCHES]		OSMAYOS	OSMAYOS	NAME ASSEMBLY, PIN, EUROCARD, TYPE 1/2R, A and C, 32/48 POSITION, 4.57[.180] SOLDER POST	
TOLERANCES UNLESS OTHERWISE SPECIFIED:		OSMAYOS	OSMAYOS	PRODUCT SPEC	
0 PLC ± -		APPLICATION SPEC		SIZE A1	
1 PLC ± -		DRAWING NO. 00779		DRAWING NO. 5650936	
2 PLC ± 0.13[.005]		WEIGHT		RESTRICTED TO	
3 PLC ± -		CUSTOMER DRAWING		SCALE 5:1	
4 PLC ± -		SHEET 1 OF 1		REV 01	
ANGLES ± -					