

THIS DRAWING IS UNPUBLISHED. RELEASED FOR PUBLICATION  
 © COPYRIGHT 2013 BY TE CONNECTIVITY. ALL RIGHTS RESERVED.

LOC	DIST	REVISIONS			
P	LTR	DESCRIPTION	DATE	DWN	APVD
DW	-	C	REVISED, CHANGE PACK. (ECR-14-002977)	24MAR14	S.C. H.L.

D

D

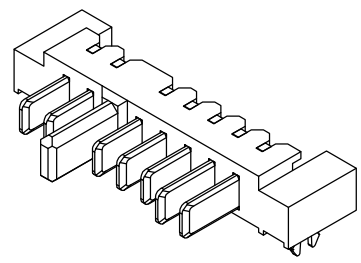
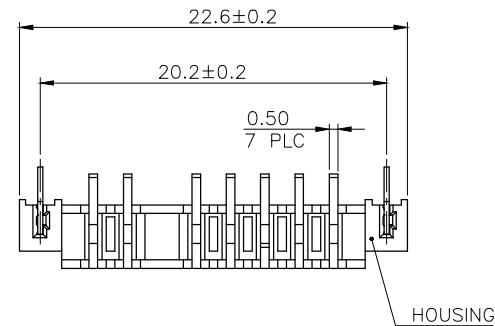

NOTES:

- MATERIAL:  
HOUSING: PA4T WITH 30% GF, UL94 V-0, BLACK COLOR.  
CONTACTS: BRASS.  
BOARDLOCKS: BRASS.
- FINISH:  
CONTACTS: (SEE TABLE) GOLD PLATED ON CONTACT AREA, 2.54μm [100μ"] MATTE-TIN ON SOLDER TAIL, WITH ENTIRE CONTACT UNDERPLATED 1.27μm [50μ"] MIN. NICKEL.  
BOARDLOCKS: 2.54μm [100μ"] MIN. MATTE-TIN OVER 1.27μm [50μ"] MIN. NICKEL PLATED.
- REFLOW SOLDER CAPABLE TO 260°C PER TEC-109-201, CONDITION B.
- SUBSTANCE RESTRICTIONS FOR LOW HALOGEN (BY WEIGHT):
  - BROMINE (Br) ≤ 900 PPM (0.09%)
  - CHLORINE (Cl) ≤ 900 PPM (0.09%)
  - TOTAL CONCENTRATION OF (Cl) + (Br) ≤ 1500PPM (0.15%)

C

C

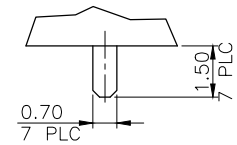
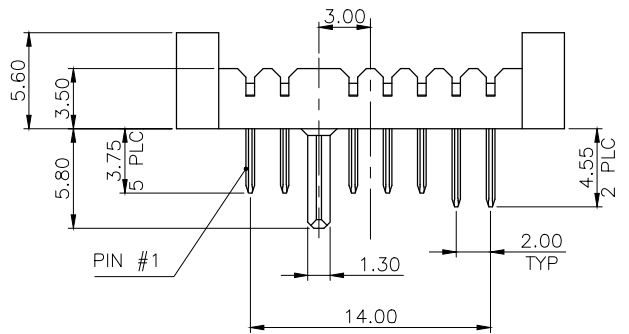

DETAIL D  
2:1

B

B

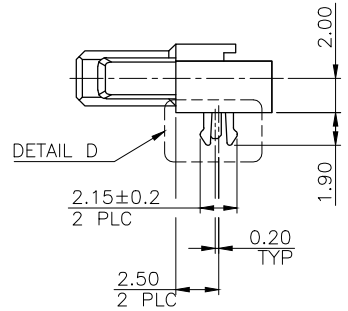
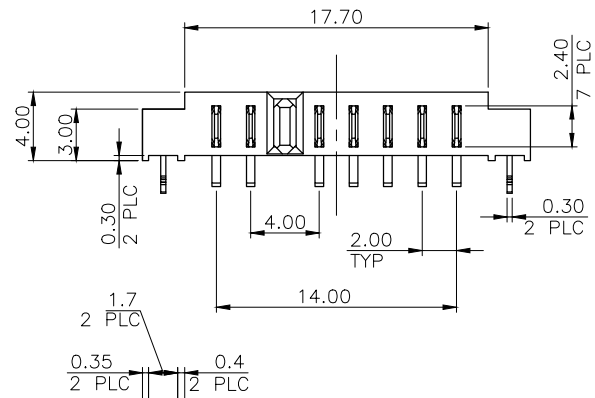

DETAIL D

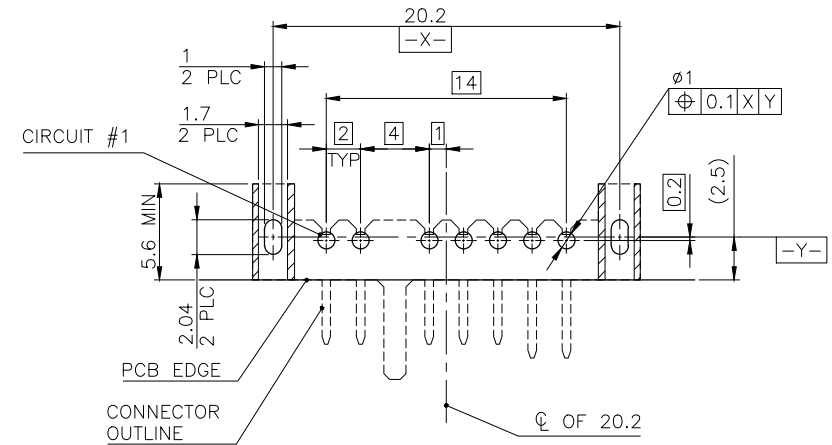

∇: STAND OFF AREA  
 TOLERANCE: ±0.05, THICKNESS: 1.0mm  
 RECOMMENDED PCB LAYOUT  
 (TOP VIEW)

0.152μm [6μ"]	2041552-1
MIN. GOLD THICKNESS	PART NUMBER

A

A

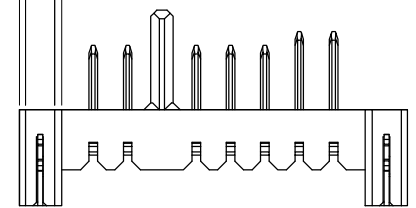

THIS DRAWING IS A CONTROLLED DOCUMENT.		DWN A. WU 20JUN2013	TE Connectivity	
DIMENSIONS: MM		CHK S. CHIEN 20JUN2013		
TOLERANCES UNLESS OTHERWISE SPECIFIED:		APVD W. KODAMA 20JUN2013	NAME	
0 PLC ± -		PRODUCT SPEC	108-57920	
1 PLC ± 0.3		APPLICATION SPEC	-	
2 PLC ± 0.2		WEIGHT	0.9g	
3 PLC ± -		RESTRICTED CUSTOMER	A300779 C=2041552	
4 PLC ± -		SCALE	-	
ANGLES ± -		SHEET	1 of 2	
MATERIAL SEE NOTE		FINISH SEE NOTE	REV C	

THIS DRAWING IS UNPUBLISHED. RELEASED FOR PUBLICATION  
 © COPYRIGHT 2013 BY TE CONNECTIVITY. ALL RIGHTS RESERVED.

LOC	DIST	REVISIONS					
DW	-	P	LTR	DESCRIPTION	DATE	DWN	APVD
				SEE SHEET 1			

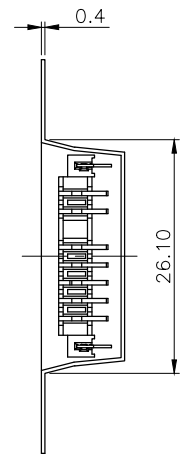
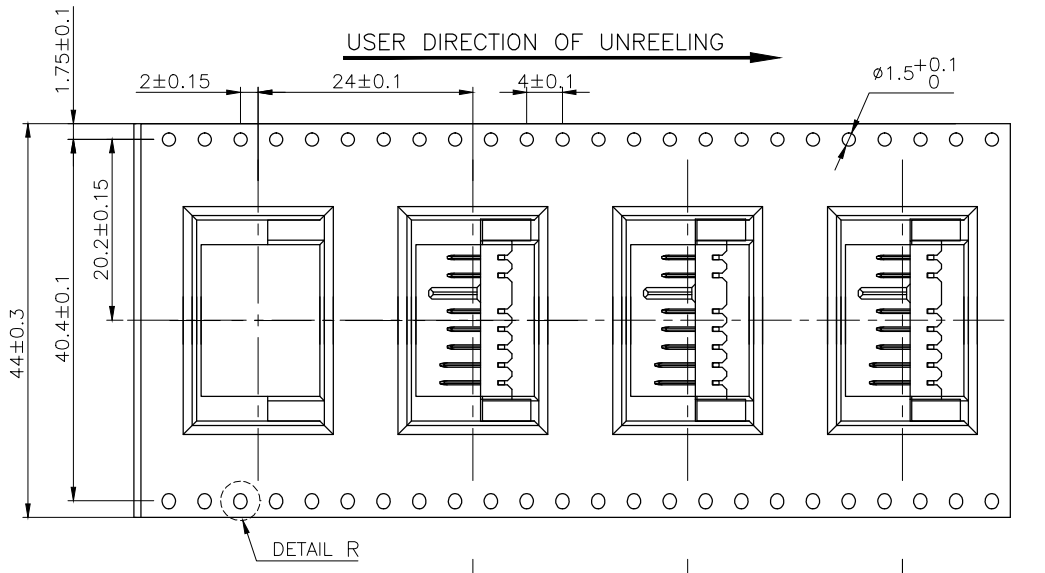
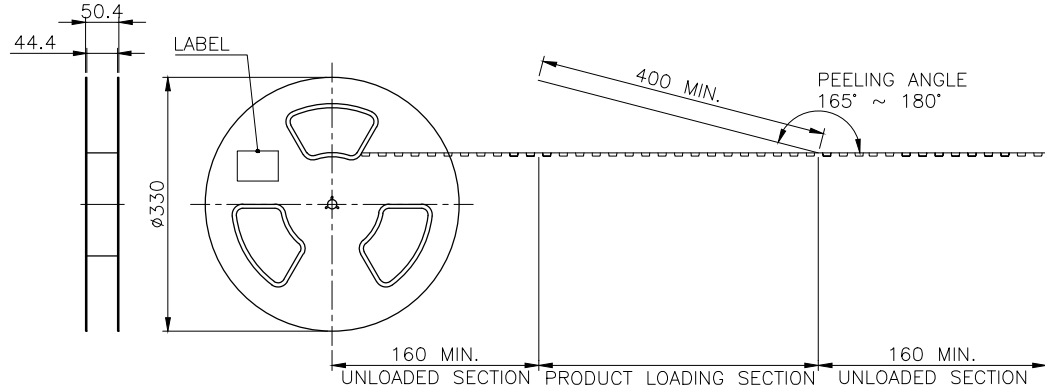

NOTES:

- MATERIAL:  
 BOX: FIBREBOARD, CORRUGATED, DOUBLE WALL.  
 COVER TAPE: POLYSTYRENES, TRANSPARENT COLOR.  
 CARRIER TAPE: POLYSTYRENES, BLACK COLOR.  
 REEL: HIPS, BLUE COLOR.  
 BAG: POLYETHYLENES, TRANSPARENT COLOR.
- EACH BAG SHALL BE INCLUDED DESICCANT.
- PEELING STRENGTH: 0.1 ~ 1.3 N (10 ~ 130 GRAMS).
- PEELING SPEED: 300 mm/min.

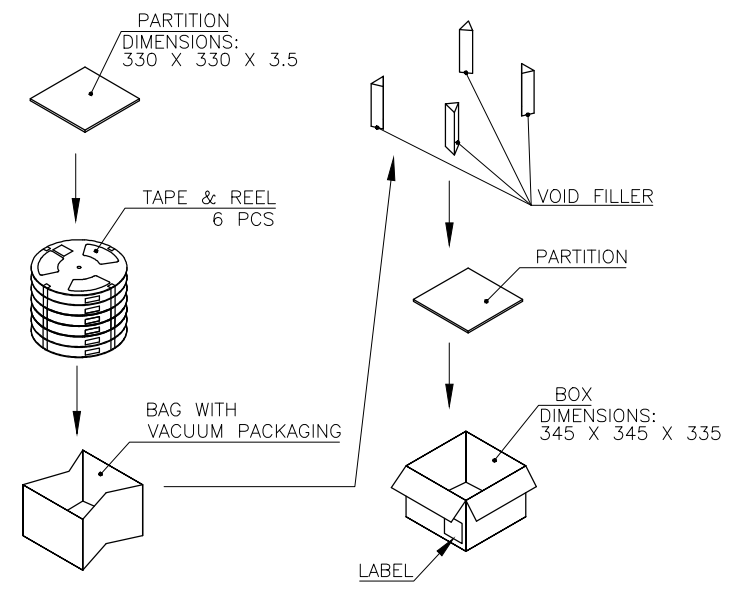

1.62 Kg	1.81 Kg	300	6	1800
NET WEIGHT	GROSS WEIGHT	PCS/TAPE	REELS/BOX	PCS/BOX

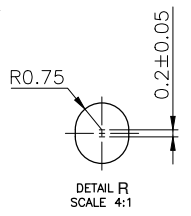

THIS DRAWING IS A CONTROLLED DOCUMENT.		DWN	-	TE Connectivity <b>2.0 MM PITCH BATTERY CONNECTOR, 7 POSITION, 4 MM HEIGHT, PLUG</b>		
DIMENSIONS: MM		CHK	-			NAME
TOLERANCES UNLESS OTHERWISE SPECIFIED:		APVD	-			PRODUCT SPEC
0 PLC ± - 1 PLC ± - 2 PLC ± - 3 PLC ± - 4 PLC ± - ANGLES ± -		APPLICATION SPEC				SIZE
MATERIAL		WEIGHT		CAGE CODE		
FINISH		RESTRICTED CUSTOMER		DRAWING NO		
				A300779C=2041552		
				RESTRICTED TO		
				SCALE		
				SHEET 2 of 2		
				REV C		