

# IS31LT3354 EVALUATION BOARD GUIDE

## DESCRIPTION

The IS31LT3354 is a continuous mode inductive step-down converter, designed for driving a single LED or multiple series connected LEDs efficiently from a voltage source higher than the required LED voltage. The device operates from an input supply between 6V and 40V and provides an externally adjustable output current of up to 2A or even higher, which is determined by the external MOSFET and inductor. The IS31LT3354 includes a high-side output current sensing circuit, which uses an external resistor to set the nominal average output current. Output current can be adjusted linearly by applying an external control signal to the ADJ pin. The ADJ pin will accept either a DC voltage or a PWM waveform. This will provide either a continuous or a gated output current.

Applying a voltage of 0.2V or lower to the ADJ pin turns the output off and switches the chip into a low current standby state.

The chip is assembled in SOT23-5 package.

## FEATURES

- Simple low parts count
- Wide input voltage range: 6V to 40V
- Output Current only limited by external component selection
- High efficiency (up to 98% )
- Typical 1200:1 dimming rate
- Typical 5% output current accuracy
- Single pin on/off and brightness control using DC voltage or PWM
- Up to 1MHz switching frequency
- Inherent open-circuit LED protection
- Thermal shutdown to protect IC itself

## QUICK START



Figure 1: Photo of IS31LT3354 Evaluation Board

## RECOMMENDED EQUIPMENT

- Power supply
- LED panel (LED arrays)

## ABSOLUTE MAXIMUM RATINGS

- Input voltage  $\leq$  30VDC

**Caution: Do not exceed the conditions listed above; otherwise the board will be damaged.**

## PROCEDURE

The IS31LT3354 demo board is fully assembled and tested. Follow the steps listed below to verify board operation.

**Caution: Do not turn on the power supply until all connections are completed.**

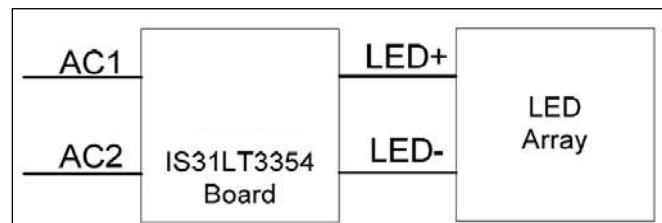

- 1) Connect the terminals of the power supply to the AC1 and AC2 pin.
- 1) Connect the negative of the LED panel (LED arrays) to the LED- terminal.
- 2) Connect the positive of the LED panel (LED arrays) to the LED+ terminal.
- 3) Turn on the power supply and the LED panel (LED arrays) will be light.

## ORDERING INFORMATION

Part No.	Temperature Range	Package
IS31LT3354_STLS2_EBDCDC	-40°C to +85°C (Industrial)	SOT23-5

Table 1: Ordering Information

For pricing, delivery, and ordering information, please contact Lumissil's analog marketing team at [analog@Lumissil.com](mailto:analog@Lumissil.com) or (408) 969-6600.

## DETAILED DESCRIPTION

### LED Current Control

The nominal average output current in the LED(s) is determined by the value of the external current sense resistor (RS) connected between VIN and ISENSE and in is given by:

$$I_{OUT\_NOM} = \frac{0.1}{R_S}$$

The table below gives values of nominal average output current for several preferred values of current setting resistor (RS) in the application circuit:

RS (Ω)	Nominal Average Output Current (mA)
0.05	2000
0.083	1200
0.15	667
0.3	333

The above values assume that the ADJ pin is floating and at a nominal voltage of  $V_{REF} = 1.2V$ . It is possible to use different values of RS if the ADJ pin is driven from an external voltage.

RS need to be chosen 1% accuracy resistor with enough power tolerance and good temperature characteristic to ensure stable output current.

### Inductor Selection

Recommended inductor values are in the range 47μH to 220μH. Higher values of inductance are recommended at higher supply voltages and low output current in order to minimize errors due to switching delays, which result in increased ripple and lower efficiency. Higher values of inductance also result in a smaller change in output current over the supply voltage range. The inductor should be mounted as close to the MOSFET as possible with low resistance connections to the drain and VIN pins.

### Switch MOSFET Selection

The IS31LT3354 demands a power N-MOSFET as a switch.

The voltage and current rating of the MOSFET must be higher than the application output voltage and the inductor peak current. The  $V_{GS(th)}$  of MOSFET should be lower than 3V and the  $R_{DSon}$  should be as lower as possible for maximum efficiency and performance. AP2306 and AP2310 are recommended.

Note: For the recommended MOSFET's the maximum load current is about 2A. For high current applications, the operating input voltage, the LED current, and the switching frequency will determine the operating temperature of the MOSFET. Switching frequency can be lowered by choosing a larger value of inductance, however, the MOSFET specifications must be carefully analyzed prior to selecting the external MOSFET. Key specifications to consider are  $R_{DSon}$  and  $C_{DS}$ , both should be as low as possible.

### PCB Layout Consideration

The Drain of the external MOSFET is a fast switching node, so PCB traces should be kept as short as possible. To minimize ground 'bounce', the ground pin of the chip should be soldered directly to the ground plane.

It is particularly important to mount the coil and the input decoupling capacitor close to the chip to minimize parasitic resistance and inductance, which will degrade efficiency. It is also important to take account of any trace resistance in series with current sense resistor RS.

The ADJ pin is a high impedance input, so when left floating, PCB traces to this pin should be as short as possible to reduce noise pickup. ADJ pin can also be connected to a voltage between 1.2V~5V. In this case, the internal circuit will clamp the output current at the value which is set by ADJ=1.2V.

Avoid running any high voltage traces close to the ADJ pin, to reduce the risk of leakage due to board contamination. Any such leakage may raise the ADJ pin voltage and cause excessive output current. A ground ring placed around the ADJ pin will minimize changes in output current under these conditions

# IS31LT3354 EVALUATION BOARD GUIDE

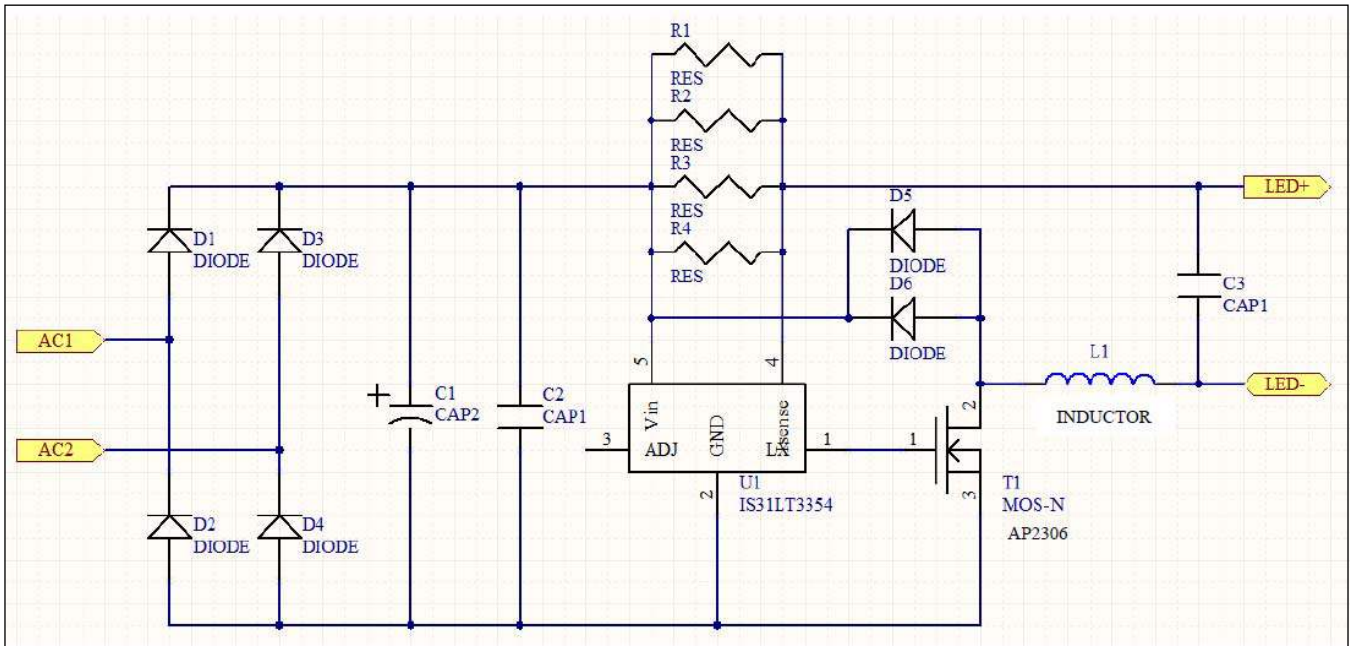

Figure 2: IS31LT3354 MR16 Application Schematic

## BILL OF MATERIALS

Name	Symbol	Description	Qty	Supplier	Part No.
Capacitor	C1	220 $\mu$ F $\pm$ 10%,50V	1		
SMD Capacitor	C2	0.1 $\mu$ F $\pm$ 10%,50V,0805	1		
SMD Capacitor	C3	1 $\mu$ F $\pm$ 10%,50V,0805	1		
SMD Resistor	R1~R4	0.24 $\Omega$ $\pm$ 1%,1206	4		
Schottky Diode	D1~D4	SS26,2A,60V	4		
Schottky Diode	D5,D6	SS16,1A,60V	2		
SMD Inductor	L1	47 $\mu$ H, $I_{SAT}$ $\geq$ 3A	1		
NMOS	T1	AP2306,5A,30V	1		
IC	U1	LED Driver	1	Lumissil	IS31LT3354

Bill of Materials, refers to Figure 2 above.

# IS31LT3354 EVALUATION BOARD GUIDE

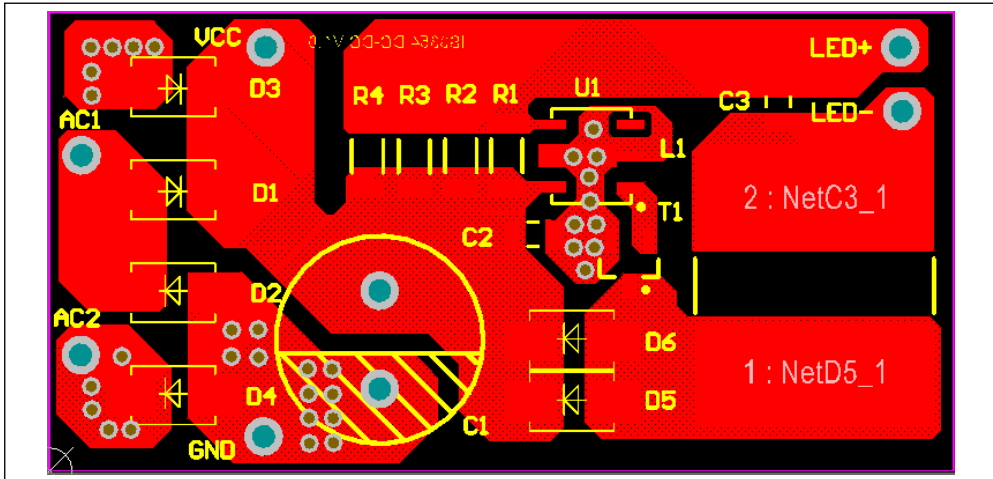

Figure 3: Board PCB Layout - Top Layer

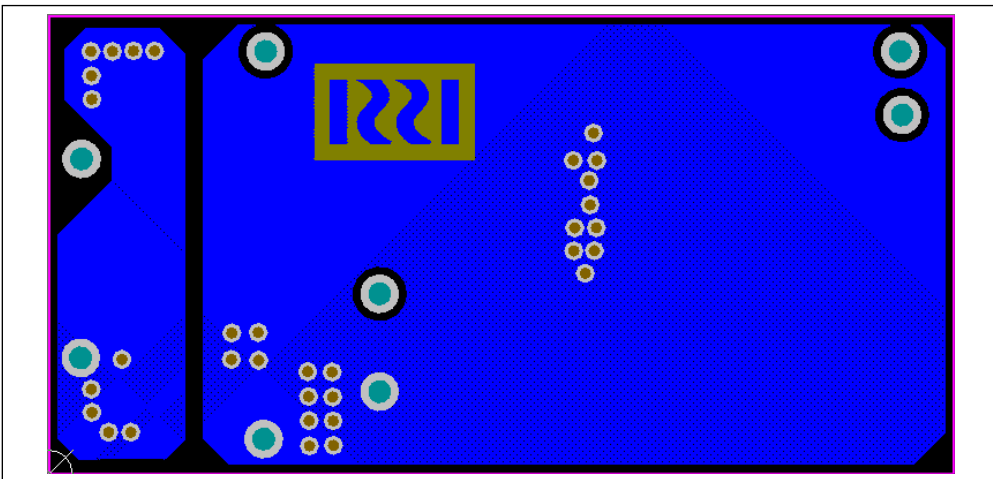

Figure 4: Board PCB Layout - Bottom Layer

Copyright © 2011 Lumissil Microsystems. All rights reserved. Lumissil Microsystems reserves the right to make changes to this specification and its products at any time without notice. Lumissil Microsystems assumes no liability arising out of the application or use of any information, products or services described herein. Customers are advised to obtain the latest version of this device specification before relying on any published information and before placing orders for products.

Lumissil Microsystems does not recommend the use of any of its products in life support applications where the failure or malfunction of the product can reasonably be expected to cause failure of the life support system or to significantly affect its safety or effectiveness. Products are not authorized for use in such applications unless Lumissil Microsystems receives written assurance to its satisfaction, that:

- a.) the risk of injury or damage has been minimized;
- b.) the user assume all such risks; and
- c.) potential liability of Lumissil Microsystems is adequately protected under the circumstances