

TLV987

3-V 10-BIT 27 MSPS AREA CCD SENSOR SIGNAL PROCESSOR

SLAS211A – MARCH 1999 – REVISED SEPTEMBER 1999

- 10-Bit, 27 MSPS, A/D Converter
- Single 3-V Supply Operation
- Low Power: 200 mW Typical at 3 V, 2 mW Power-Down Mode
- Differential Nonlinearity Error: $< \pm 0.6$ LSB Typ
- Integral Nonlinearity Error: $< \pm 2$ LSB Typ
- Programmable Gain Amplifier (PGA) With 0-dB to 36-dB Gain Range (0.09 dB/step)
- Automatic or Programmable Black Level and Offset Calibration
- Additional DACs for External Analog Setting
- Serial Interface for Register Configuration
- Internal Reference Voltages
- 48-Pin TQFP Package

applications

- Digital Still Camera
- Digital Camcorder
- Digital Video Camera

description

The TLV987 is a highly integrated monolithic analog signal processor/digitizer designed to interface the area charge-coupled device (CCD) sensors in digital camera applications. The TLV987 performs all the analog processing functions necessary to maximize the dynamic range, corrects various errors associated with the CCD sensor, and then converts the results from analog to digital using the on-chip high-speed analog-to-digital converter (ADC). The key components of the TLV987 include input clamp circuitry, a correlated double sampler (CDS), and a programmable gain amplifier (PGA). The PGA has 0-dB to 36-dB gain range. In addition, the TLV987 has two internal digital-to-analog converters (DACs) for automatic or programmable optical black level and offset calibration. The TLV987 also has two additional DACs for external system control, and internal reference voltages. The TLV987 has a parallel data port for easy microprocessor interface and a serial port for configuring internal control registers.

Designed in advanced CMOS process, the TLV987 operates from a single 3-V power supply with a normal power consumption of 200 mW and a 2 mW power-down mode.

Very high throughput rate, single 3-V operation, low power consumption, and fully integrated analog processing circuitry make the TLV987 an ideal CCD sensor interfacing solution for digital camera applications.

The device is available in a 48-pin TQFP package and is characterized for operation over 0°C to 70°C operating free-air temperature range.

AVAILABLE OPTIONS

T _A	PACKAGE
	TQFP (PFB)
0°C to 70°C	TLV987CPFB

PFB PACKAGE
(TOP VIEW)

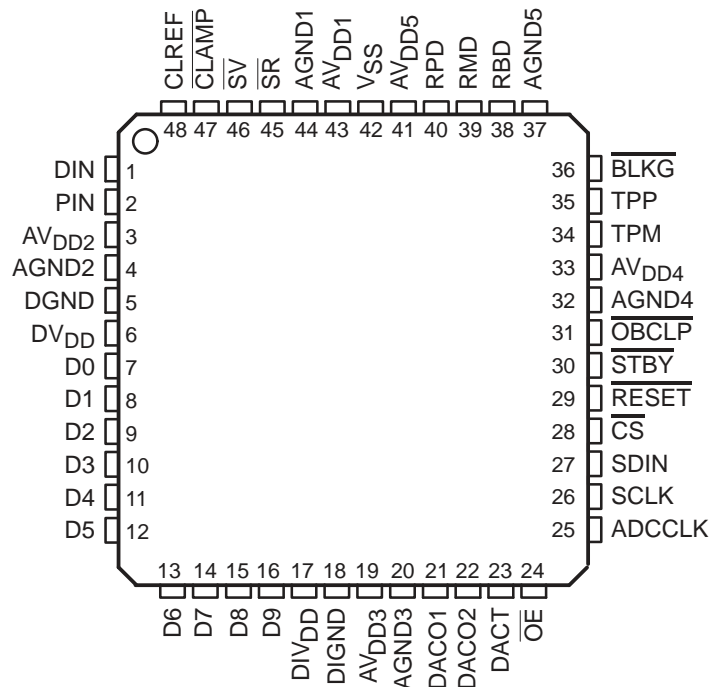

Please be aware that an important notice concerning availability, standard warranty, and use in critical applications of Texas Instruments semiconductor products and disclaimers thereto appears at the end of this data sheet.

TI is a trademark of Texas Instruments Incorporated.

PRODUCTION DATA information is current as of publication date. Products conform to specifications per the terms of Texas Instruments standard warranty. Production processing does not necessarily include testing of all parameters.



POST OFFICE BOX 655303 • DALLAS, TEXAS 75265

Copyright © 1999, Texas Instruments Incorporated

TLV987

3-V 10-BIT 27 MSPS AREA CCD SENSOR SIGNAL PROCESSOR

SLAS211A – MARCH 1999 – REVISED SEPTEMBER 1999

functional block diagram

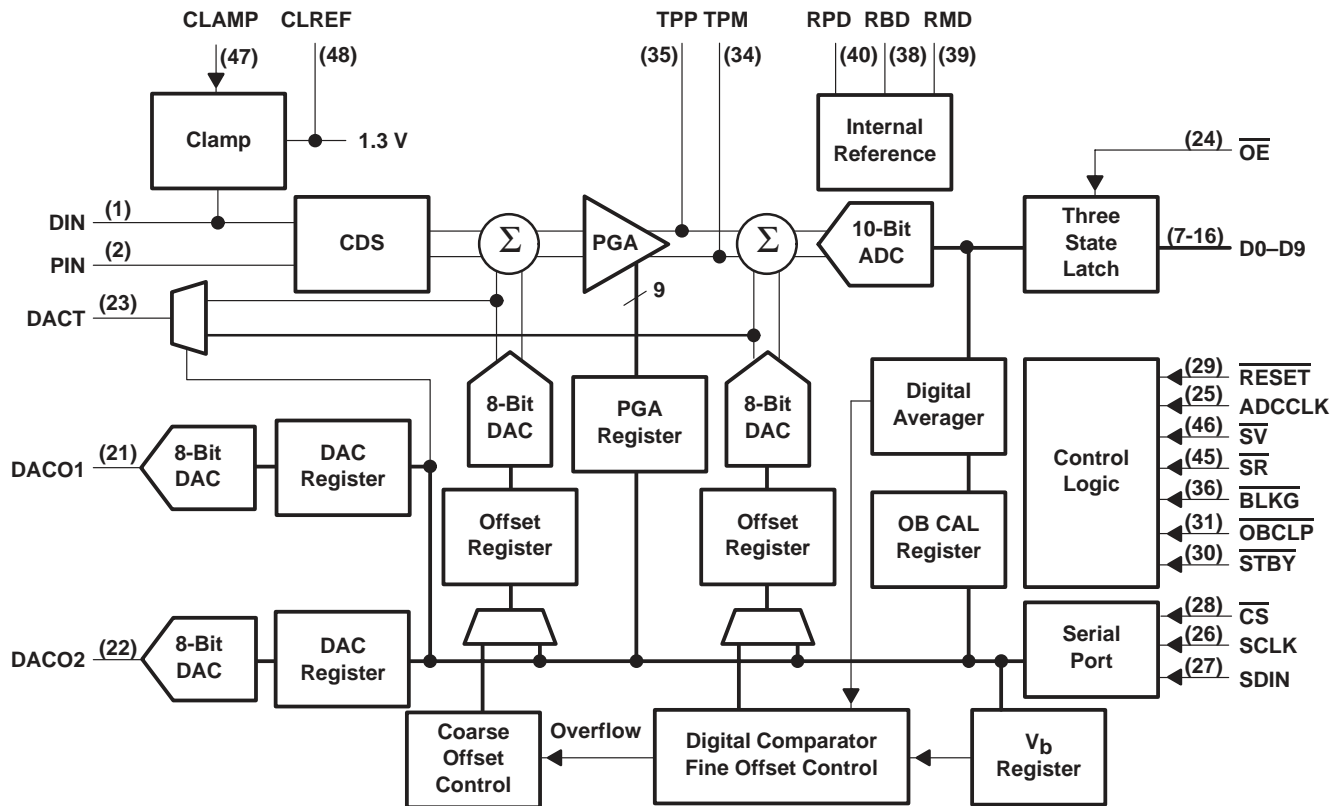

Terminal Functions

TERMINAL NAME	NO.	I/O	DESCRIPTION
ADCCLK	25	I	ADC clock input.
AGND1	44		Analog ground for internal CDS circuits
AGND2	4		Analog ground for internal PGA circuits
AGND3	20		Analog ground for internal DAC circuits
AGND4	32		Analog ground for internal ADC circuits
AGND5	37		Analog ground for internal REF circuits
AV _{DD1}	43		Analog supply voltage for internal CDS circuits, 3 V
AV _{DD2}	3		Analog supply voltage for internal PGA circuits, 3 V
AV _{DD3}	19		Analog supply voltage for internal DAC circuits, 3 V
AV _{DD4}	33		Analog supply voltage for internal ADC circuits, 3 V
AV _{DD5}	41		Analog supply voltage for internal ADC circuits, 3 V
$\overline{\text{BLKG}}$	36	I	Control input. CDS operation is disabled when $\overline{\text{BLKG}}$ is pulled low.
$\overline{\text{CLAMP}}$	47	I	CCD signal clamp control input
CLREF	48	O	Clamp reference voltage output.
$\overline{\text{CS}}$	28	I	Chip select. A logic low on this input enables the TLV987.
DACO1	21	O	Digital-to-analog converter output1
DACO2	22	O	Digital-to-analog converter output2
DACT	23	O	MUXed test output for internal offset DACs
DGND	5		Digital ground
DIGND	18		Digital interface circuit ground
DIN	1	I	Input signal from CCD
DIV _{DD}	17		Digital interface circuit supply voltage, 1.8 V to 4.4 V
DV _{DD}	6		Digital supply voltage, 3 V
D0 – D9	7 – 16	O	10-bit three-state ADC output data or offset DACs test data
$\overline{\text{OBCLP}}$	31	I	Optical black level and offset calibration control input. Active low.
$\overline{\text{OE}}$	24	I	Output data enable. Active low.
PIN	2	I	Input signal from CCD
RBD	38	O	Internal bandgap reference for external decoupling
RMD	39	O	Ref– output for external decoupling
RPD	40	O	Ref+ output for external decoupling
$\overline{\text{RESET}}$	29	I	Hardware reset input, active low. This signal forces a reset of all internal registers.
SCLK	26	I	Serial clock input. This clock synchronizes the serial data transfer.
SDIN	27	I	Serial data input to configure the internal registers.
$\overline{\text{SR}}$	45	I	CCD reference level sample clock input
$\overline{\text{STBY}}$	30	I	Hardware power-down control input, active low
$\overline{\text{SV}}$	46	I	CCD signal level sample clock input
TPM	34	O	MUXed test output: PGA noninverting output or inverted PGA clock
TPP	35	O	MUXed test output: PGA inverting output or inverted CDS clock
V _{SS}	42		Silicon substrate, normally connected to analog ground

TLV987
3-V 10-BIT 27 MSPS AREA CCD SENSOR
SIGNAL PROCESSOR

SLAS211A – MARCH 1999 – REVISED SEPTEMBER 1999

absolute maximum ratings over operating free-air temperature (unless otherwise noted)†

Supply voltage range, V_{DD} , DV_{DD} , DIV_{DD}	-0.3 V to 6.5V
Analog input voltage range	-0.3 V to $V_{DD}+0.3$ V
Digital input voltage range	-0.3 V to $DV_{DD}+0.3$ V
Operating virtual junction temperature range, T_J	-40°C to 150°C
Operating free-air temperature range, T_A	0°C to 70°C
Storage temperature range, T_{stg}	-65°C to 150°C
Lead temperature 1.6 mm (1/16 inch) from case for 10 seconds	260°C

† Stresses beyond those listed under “absolute maximum ratings” may cause permanent damage to the device. These are stress ratings only, and functional operation of the device at these or any other conditions beyond those indicated under “recommended operating conditions” is not implied. Exposure to absolute-maximum-rated conditions for extended periods may affect device reliability.

recommended operating conditions

power supplies

	MIN	NOM	MAX	UNIT
Analog supply voltage, V_{DD}	2.7	3	3.3	V
Digital supply voltage, DV_{DD}	2.7	3	3.3	V
Digital interface supply voltage, DIV_{DD}	1.8		4.4	V

digital inputs

		MIN	NOM	MAX	UNIT
High-level input voltage, V_{IH}	$DIV_{DD} = 3$ V	0.8 DIV_{DD}			V
Low-level input voltage, V_{IL}	$DIV_{DD} = 3$ V			0.2 DIV_{DD}	V
Clock frequency, ADCCLK, f_{clock1}	$DV_{DD} = 3$ V			27	MHz
Pulse duration, ADCCLK, high, $t_w(CLKH)1$	$DV_{DD} = 3$ V	18.5			ns
Pulse duration, ADCCLK, low, $t_w(CLKL)1$	$DV_{DD} = 3$ V	18.5			ns
Clock frequency, SCLK, f_{clock2}	$DV_{DD} = 3$ V			40	MHz
Pulse duration, SCLK high, $t_w(CLKH)2$	$DV_{DD} = 3$ V	12.5			ns
Pulse duration, SCLK low, $t_w(CLKL)2$	$DV_{DD} = 3$ V	12.5			ns



TLV987
**3-V 10-BIT 27 MSPS AREA CCD SENSOR
 SIGNAL PROCESSOR**

SLAS211A – MARCH 1999 – REVISED SEPTEMBER 1999

**electrical characteristics over recommended operating free-air temperature range,
 $AV_{DD} = DV_{DD} = 3\text{ V}$, $ADCCLK = 27\text{ MHz}$ (unless otherwise noted)**

total device

PARAMETER		TEST CONDITIONS	MIN	TYP	MAX	UNIT
AI _{CC}	Analog operating supply current			66		mA
DI _{CC}	Digital operation supply current			1		mA
	Device power consumption			200		mW
	Power consumption in power-down mode			2		mW
DNL	Full channel differential nonlinearity		-1	±0.6	1.5	LSB
INL	Full channel integral nonlinearity			±2		LSB

analog-to-digital converter (ADC)

PARAMETER		TEST CONDITIONS	MIN	TYP	MAX	UNIT
	ADC resolution				10	Bits
	Full-scale input span			2		V _{PP}
	Conversion rate				27	MHz
	ADC output latency			4.5		CLK cycles
	No missing codes			Assured		

correlated double sampler (CDS) and programmable gain amplifier (PGA)

PARAMETER		TEST CONDITIONS	MIN	TYP	MAX	UNIT
	CDS and PGA sample rate				27	MHz
	CDS full-scale input span	Single-ended input			1	V
	Input capacitance of CDS			4		pF
	Minimum PGA gain			0	1	dB
	Maximum PGA gain		35	36	37	dB
	PGA gain resolution			0.09		dB
	PGA programming code resolution	8-bit monotonic gain control		9		Bits

internal digital-to-analog converters (DAC) for offset correction

PARAMETER		TEST CONDITIONS	MIN	TYP	MAX	UNIT
	DAC resolution				8	Bits
INL	Integral nonlinearity			±0.6	±1.2	LSB
DNL	Differential nonlinearity			±0.5	±.99	LSB
	Output settling time	To 1% accuracy		80		ns

user digital-to-analog converters (DAC)

PARAMETER		TEST CONDITIONS	MIN	TYP	MAX	UNIT
	DAC resolution				8	Bits
INL	Integral nonlinearity			±0.5	±1.2	LSB
DNL	Differential nonlinearity			±0.5	±.99	LSB
	Output voltage		0		AV _{DD}	V
	Output settling time	10-pF external load, Settle to 1 mV		4		μs



TLV987
3-V 10-BIT 27 MSPS AREA CCD SENSOR
SIGNAL PROCESSOR

SLAS211A – MARCH 1999 – REVISED SEPTEMBER 1999

electrical characteristics over recommended operating free-air temperature range,
 $AV_{DD} = DV_{DD} = 3\text{ V}$, $ADCCLK = 27\text{ MHz}$ (unless otherwise noted)

reference voltages

	TEST CONDITIONS	MIN	TYP	MAX	UNIT
Internal bandgap voltage reference		1.43	1.5	1.58	V
Temperature coefficient			100		ppm/°C
Voltage reference noise			0.5		LSB
Positive reference voltage, ADC Ref+	Externally decoupled	1.8	2	2.2	V
Negative reference voltage, ADC Ref-	Externally decoupled	0.8	1	1.2	V

digital specifications

PARAMETER	TEST CONDITIONS	MIN	TYP	MAX	UNIT
LOGIC INPUTS					
I_{IH}	High-level input current DIV _{DD} = 3 V	-10		10	μA
I_{IL}	Low-level input current DIV _{DD} = 3 V	-10		10	μA
C_i	Input capacitance		5		pF
LOGIC OUTPUTS					
V_{OH}	High-level output voltage $I_{OH} = 50\text{ μA}$, DIV _{DD} = 3 V		DIV _{DD} -0.4		V
V_{OL}	Low-level output voltage $I_{OL} = 50\text{ μA}$, DIV _{DD} = 3 V		0.4		V
I_{OZ}	High-impedance output current	-10		10	μA
C	Output capacitance		5		pF

timing requirements

PARAMETER	TEST CONDITIONS	MIN	TYP	MAX	UNIT
$t_w(SR)$	Pulse duration, SR		10		ns
$t_w(SV)$	Pulse duration, SV		10		ns
t_{su1}	Setup time, OBCLP ↓ before ADCCLK ↑				
t_{h2}	Hold time, ADCCLK ↓ after OBCLP ↑				
t_d	Delay time, ADCCLK ↓ to ADCOUT valid	4		9	ns
t_{su2}	Setup time, CS ↓ before SCLK ↑	0			ns
t_{h1}	Hold time, SCLK ↓ after CS ↑	5			ns

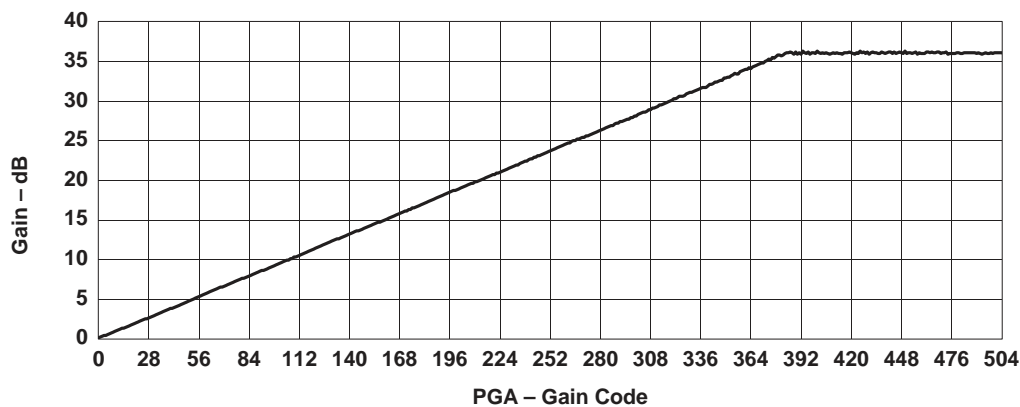

Figure 1. TLV987 PGA Gain Code vs Gain



PARAMETER MEASUREMENT INFORMATION

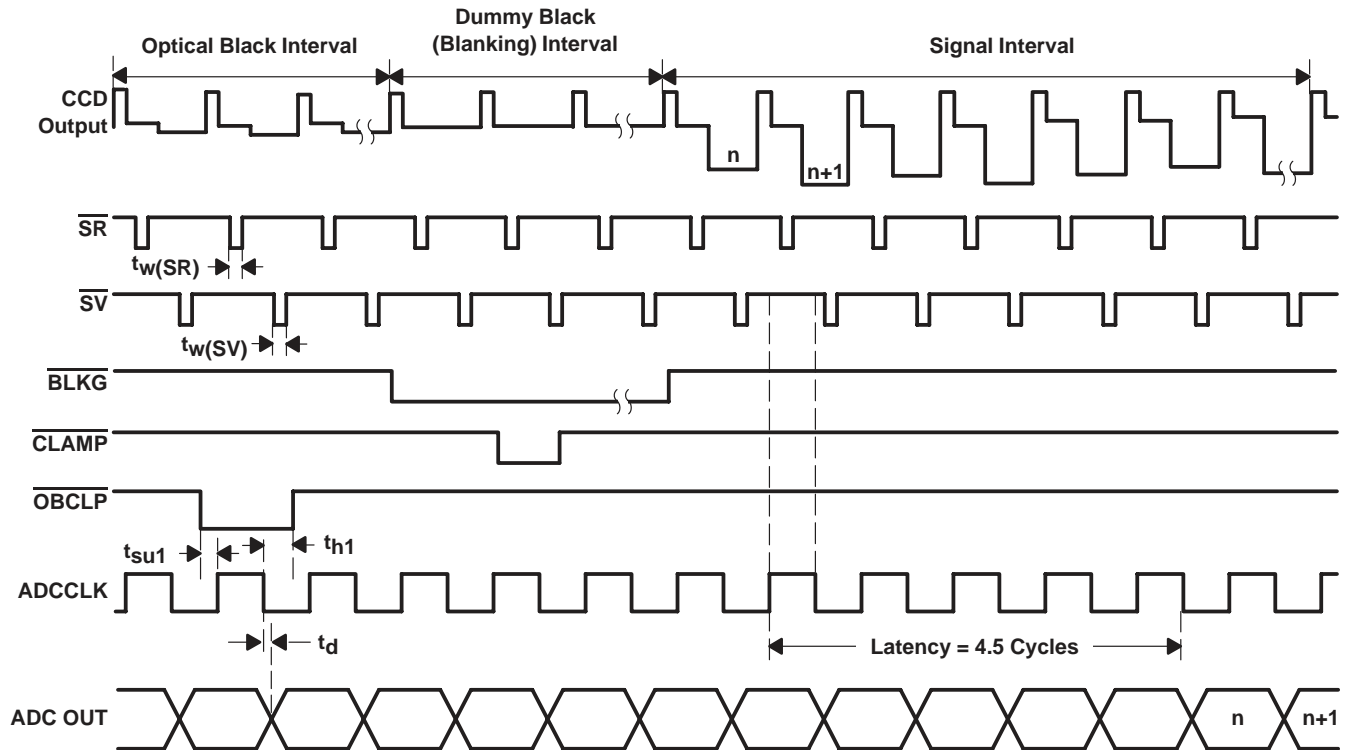

Figure 2. System Operation Timing Diagram

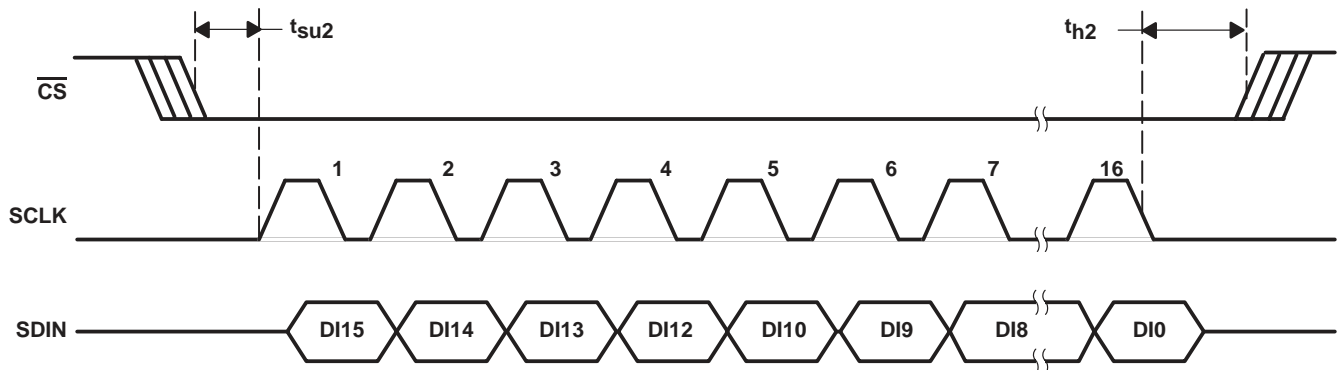
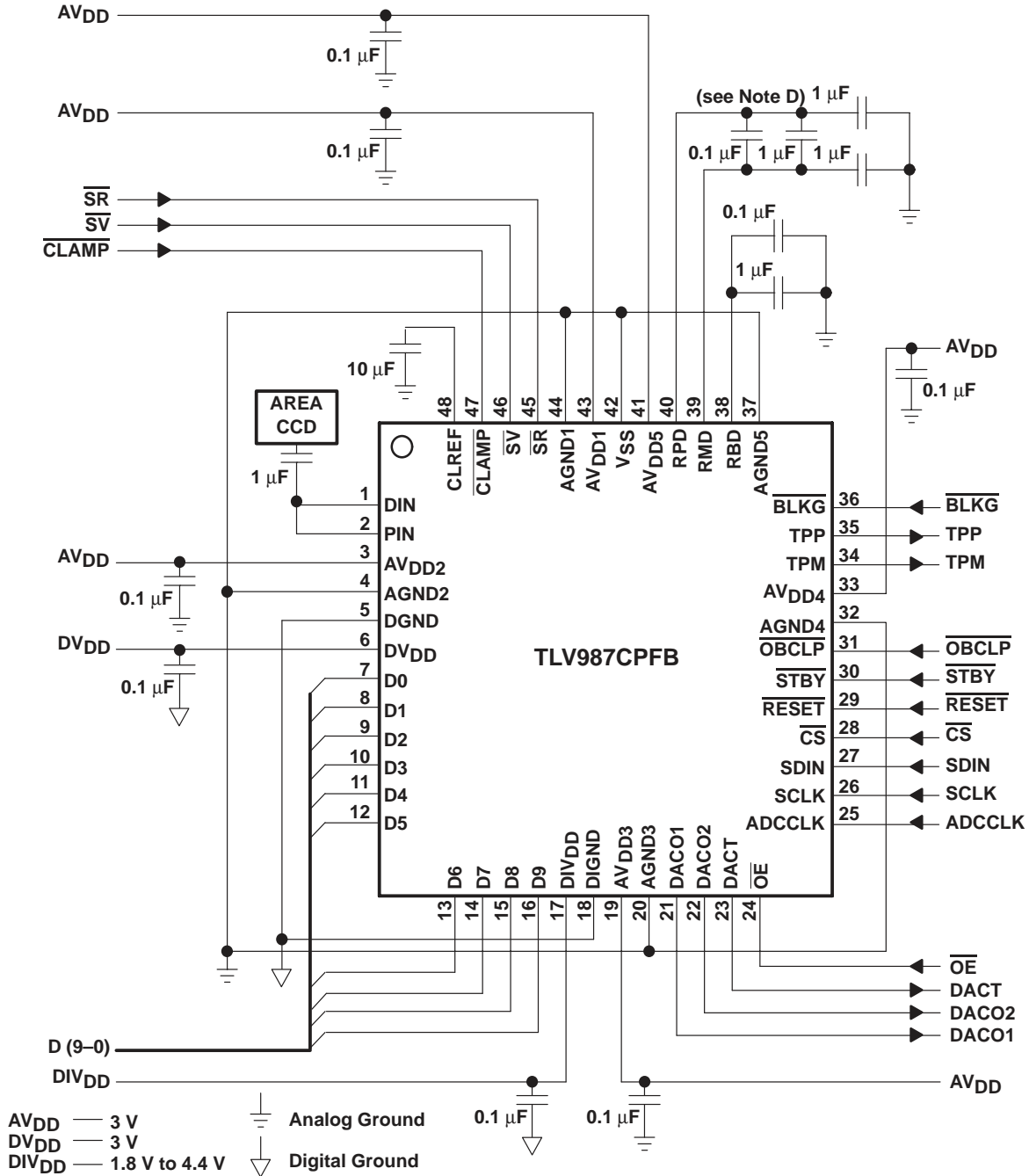

Figure 3. Timing Diagram

TLV987
3-V 10-BIT 27 MSPS AREA CCD SENSOR
SIGNAL PROCESSOR

SLAS211A – MARCH 1999 – REVISED SEPTEMBER 1999

APPLICATION INFORMATION



- NOTES:
- All analog outputs should be buffered if the load is resistive or if the load is capacitive with more than 2-pF loading.
 - When using the TPP and TPM pins to test internal PGA, the AVDD supply voltage should be 3.3 V.
 - Clock signals on the TPP and TPM pins are inverted.
 - These two capacitors should be placed as close to the device as possible.

Figure 4. Typical Application Connections



PRINCIPLES OF OPERATION

register definitions

serial input data format

DI15	DI14	DI13	DI12	DI11	DI10	DI9	DI8	DI7	DI6	DI5	DI4	DI3	DI2	DI1	DI0
X	X	A3	A2	A1	A0	D9	D8	D7	D6	D5	D4	D3	D2	D1	D0

A3	A2	A1	A0	
0	0	0	0	Control register.
0	0	0	1	PGA gain register
0	0	1	0	User DAC 1 register
0	0	1	1	User DAC 2 register
0	1	0	0	Coarse offset DAC
0	1	0	1	Fine offset DAC
0	1	1	0	Digital Vb register. Set reference code level at the ADC output during the optical black interval
0	1	1	1	Optical black register. Set the number of black pixels per line and number of lines for digital averaging
1	0	0	0	Test register

D9 – D0

10-bit data to be written into the selected register

control register format

D9	D8	D7	D6	D5	D4	D3	D2	D1	D0
STBY	PDD1	PDD2	ACD	AFD	X	X	X	RTOB	RTSY

control register description

BIT	NAME	DESCRIPTION
D9	STBY	Device power down control: 1 = standby, 0 = active (default)
D8	PDD1	Power down the user DAC1: 1 = standby, 0 = active (default)
D7	PDD2	Power down the user DAC2: 1 = standby, 0 = active (default)
D6	ACD	Coarse offset DAC mode control: 0 = Auto calibration (default) 1 = Bypass auto calibration Note: When D6 is set to 0, D5 must also be set to 0 (auto mode); otherwise, the auto mode will be disabled on both offset DACs.
D5	AFD	Fine offset DAC mode control: 0 = Auto calibration (default) 1 = Bypass auto calibration Note: D5 can be set to 0 with or without D6 being set to 0.
D4 – D2	X	Reserved
D1	RTOB	A write of a 1 to this bit resets the calculated black level results in the digital averager.
D0	RTSY	A write of a 1 to this bit resets the entire system to the default settings.

TLV987
3-V 10-BIT 27 MSPS AREA CCD SENSOR
SIGNAL PROCESSOR

SLAS211A – MARCH 1999 – REVISED SEPTEMBER 1999

PRINCIPLES OF OPERATION

PGA register format

D9	D8	D7	D6	D5	D4	D3	D2	D1	D0
X	Bit8	Bit7	Bit6	Bit5	Bit4	Bit3	Bit2	Bit1	Bit0

Default PGA gain = X000000000 or 0dB

user DAC1 and DAC2 registers format

D9	D8	D7	D6	D5	D4	D3	D2	D1	D0
X	X	Bit7	Bit6	Bit5	Bit4	Bit3	Bit2	Bit1	Bit0

Default user DAC register value = XX00000000

coarse offset DAC register format

D9	D8	D7	D6	D5	D4	D3	D2	D1	D0
X	SIGN	Bit7	Bit6	Bit5	Bit4	Bit3	Bit2	Bit1	Bit0

coarse offset DAC register description

BIT	NAME	DESCRIPTION
D9	X	Reserved
D8	SIGN	Coarse DAC sign bit, 0 = + sign (default), 1 = – sign
D7–D0		Coarse DAC control data when D6 in the control register is set to 1

Default coarse DAC register value = X000000000

fine offset DAC register format

D9	D8	D7	D6	D5	D4	D3	D2	D1	D0
X	SIGN	Bit7	Bit6	Bit5	Bit4	Bit3	Bit2	Bit1	Bit0

fine offset DAC register description

BIT	NAME	DESCRIPTION
D9	X	Reserved
D8	SIGN	Fine DAC sign bit, 0 = + sign (default), 1 = – sign
D7–D0		Fine DAC control data when D5 in the control register is set to 1

Default fine DAC register value = X000000000

digital Vb (optical black level) register format

D9	D8	D7	D6	D5	D4	D3	D2	D1	D0
Bit9	Bit8	Bit7	Bit6	Bit5	Bit4	Bit3	Bit2	Bit1	Bit0

Default Vb register value = 40 Hex.



PRINCIPLES OF OPERATION

optical black calibration register format

D9	D8	D7	D6	D5	D4	D3	D2	D1	D0
OMUX1	OMUX0	LN4	LN3	LN2	LN1	MP	PN2	PN1	PN0

optical black calibration register description

BIT	NAME	DESCRIPTION															
D9, D8	OMUX1, OMUX0	<p>These two bits multiplex digital output (data presented at D(9–0) pins):</p> <table style="width: 100%; border-collapse: collapse;"> <tr> <td style="padding-right: 10px;">OMUX1</td> <td style="padding-right: 10px;">OMUX0</td> <td></td> </tr> <tr> <td style="text-align: center;">0</td> <td style="text-align: center;">0</td> <td>D(9–0) = ADC output (default)</td> </tr> <tr> <td style="text-align: center;">0</td> <td style="text-align: center;">1</td> <td>D(9–0) = ADC output</td> </tr> <tr> <td style="text-align: center;">1</td> <td style="text-align: center;">0</td> <td>D9 = Fine/coarse (1/0) auto-correction flag D8 = Coarse DAC sign D(7–0) = Coarse DAC value</td> </tr> <tr> <td style="text-align: center;">1</td> <td style="text-align: center;">1</td> <td>D9 = Fine/coarse (1/0) auto-correction flag D8 = Fine DAC sign D(7–0) = Fine DAC value</td> </tr> </table>	OMUX1	OMUX0		0	0	D(9–0) = ADC output (default)	0	1	D(9–0) = ADC output	1	0	D9 = Fine/coarse (1/0) auto-correction flag D8 = Coarse DAC sign D(7–0) = Coarse DAC value	1	1	D9 = Fine/coarse (1/0) auto-correction flag D8 = Fine DAC sign D(7–0) = Fine DAC value
OMUX1	OMUX0																
0	0	D(9–0) = ADC output (default)															
0	1	D(9–0) = ADC output															
1	0	D9 = Fine/coarse (1/0) auto-correction flag D8 = Coarse DAC sign D(7–0) = Coarse DAC value															
1	1	D9 = Fine/coarse (1/0) auto-correction flag D8 = Fine DAC sign D(7–0) = Fine DAC value															
D7–D4	LN4–LN0	<p>Number of black lines for moving average = 2^L</p> <p>L can be 0, 1, 2, 3, 4, 5, 6, 7, and 8. Or number of lines can be 1 (default), 2, 4, 8, 16, 32, 64, 128, and 256.</p> <p>The maximum number of lines is 256 even if $L > 8$.</p>															
D3	MP	<p>When this bit is 1, the number of black pixels to be averaged per line (2^N) is multiplied by 3.</p> <p>By setting the MP and PN2–PN0 bits together, the number of optical black pixels can be programmed to have the following numbers: 1, 2, 3 (1 x 3), 4, 6 (2 x 3), 8, 12 (4 x 3), 16, 24 (8 x 3), 32, 48 (16 x 3), 64, 96 (32 x 3), and 192 (64 x 3).</p> <p>Default: MP = 0, no multiplication</p>															
D2–D0	PN2–PN0	<p>Number of black pixels per line to average = 2^N</p> <p>N can be 0, 1, 2, 3, 4, 5, and 6. Or number of pixels per line can be 1, 2, 4, 8 (default), 16, 32, and 64.</p> <p>The maximum number of pixels per line is 64 even if $N > 6$.</p>															

Default optical black calibration register value = 0000000011

TLV987
3-V 10-BIT 27 MSPS AREA CCD SENSOR
SIGNAL PROCESSOR

SLAS211A – MARCH 1999 – REVISED SEPTEMBER 1999

PRINCIPLES OF OPERATION

test register format

D9	D8	D7	D6	D5	D4	D3	D2	D1	D0
TB9	TB8	TB7	TB6	TB5	TB4	TB3	TB2	TB1	TB0

Default test register value = 1010000000

test register description

BIT	NAME	DESCRIPTION												
D9 – D6	TB9 – TB6	These four bits are used to program the internal DC bias current. The bias current programming uses the following equation: $I_{bias} = 8 \mu A + (code) \times 2 \mu A$ Hence, I_{bias} varies from 8 μA (code=0000) to 38 μA (code=1111), with a linear step of 2 μA . The recommended setting of the code is 1010 which sets the nominal I_{bias} value to 28 μA .												
D5, D4	TB5, TB4	Test outputs (pin 34/35 – TPM/TPP) control: <table border="0"> <tr> <td>TB5</td> <td>TB4</td> <td></td> </tr> <tr> <td>0</td> <td>0 or 1</td> <td>High impedance outputs at pin TPP and TPM.</td> </tr> <tr> <td>1</td> <td>0</td> <td>Inverted internal CDS clock at pin TPP, Inverted internal PGA clock at pin TPM.</td> </tr> <tr> <td>1</td> <td>1</td> <td>PGA non-inverting output at pin TPP, PGA inverting output at pin TPM.</td> </tr> </table>	TB5	TB4		0	0 or 1	High impedance outputs at pin TPP and TPM.	1	0	Inverted internal CDS clock at pin TPP, Inverted internal PGA clock at pin TPM.	1	1	PGA non-inverting output at pin TPP, PGA inverting output at pin TPM.
TB5	TB4													
0	0 or 1	High impedance outputs at pin TPP and TPM.												
1	0	Inverted internal CDS clock at pin TPP, Inverted internal PGA clock at pin TPM.												
1	1	PGA non-inverting output at pin TPP, PGA inverting output at pin TPM.												
D3	TB3	1 = Use external reference, power down internal reference 0 = Use internal reference (default).												
D2	TB2	Reserved												
D1, D0	TB1, TB0	Test output (pin 23, DACT) control for offset DACs: <table border="0"> <tr> <td>TB1</td> <td>TB0</td> <td></td> </tr> <tr> <td>0</td> <td>0 or 1</td> <td>High impedance outputs at pin DACT (default = 00)</td> </tr> <tr> <td>1</td> <td>0</td> <td>Fine offset DAC output at pin DACT</td> </tr> <tr> <td>1</td> <td>1</td> <td>Coarse offset DAC output at pin DACT</td> </tr> </table>	TB1	TB0		0	0 or 1	High impedance outputs at pin DACT (default = 00)	1	0	Fine offset DAC output at pin DACT	1	1	Coarse offset DAC output at pin DACT
TB1	TB0													
0	0 or 1	High impedance outputs at pin DACT (default = 00)												
1	0	Fine offset DAC output at pin DACT												
1	1	Coarse offset DAC output at pin DACT												



PRINCIPLES OF OPERATION

CDS/PGA signal processor

The output from the CCD sensor is first fed to a correlated double sampler (CDS). The CCD signal is sampled and held during the reset reference interval and the video signal interval. By subtracting two resulting voltage levels, the CDS removes low-frequency noise from the output of the CCD sensor and obtains the voltage difference between the CCD reference level and the video level of each pixel. Two sample and hold control pulses (\overline{SR} and \overline{SV}) are required to perform the CDS function.

The CCD output is capacitively coupled to the TLV987. The ac coupling capacitor is clamped to establish proper dc bias during the dummy pixel interval by the \overline{CLAMP} input. The bias at the input to the TLV987 is set to 1.3 V. Normally, \overline{CLAMP} is applied at the sensor's line rate. A capacitor, with a value ten times larger than that of the input ac coupling capacitor, should be connected between the \overline{CLREF} pin and the AGND pin.

When operating the TLV987 at its maximum speed, the CCD internal source resistance should be smaller than 50 Ω . Otherwise, CCD output buffering is required.

The signal is sent to the PGA after the CDS function is complete. The PGA gain can be adjusted from 0 dB to 36 dB by programming the internal gain register via the serial port. The PGA is digitally controlled with 9-bit resolution on a linear dB scale, resulting in a 0.09-dB gain step. The gain can be expressed by the following equation:

$$\text{Gain} = \text{PGA code} \times 0.09375 \text{ dB}$$

Where, the PGA code has a range of 0 to 383.

For example, if the PGA code = 64, then the PGA gain = 6 dB (or gain of 2)

The TLV987 has direct access to the PGA outputs through the TPP pin and the TPM pin. See *test register description* paragraph for details.

ADC

The ADC employs a pipelined architecture to achieve high throughput and low power consumption. Fully differential implementation and digital error correction ensure 10-bit resolution.

The latency of the ADC data output is 4.5 ADCCLK cycles as shown in Figure 2. Pulling the \overline{OE} pin (pin 24) high puts the ADC output in high impedance.

user DACs

The TLV987 includes two user DACs that can be used for external analog settings. The output voltage of each DAC can be independently set and has a range of 0 V to the supply voltage with 8-bit resolution. When the user DACs are not used in a camera system, they can be put in the standby mode by programming control bits in the control register.

TLV987

3-V 10-BIT 27 MSPS AREA CCD SENSOR SIGNAL PROCESSOR

SLAS211A – MARCH 1999 – REVISED SEPTEMBER 1999

PRINCIPLES OF OPERATION

internal timing

The \overline{SR} and \overline{SV} signals are required to operate the CDS as previously explained. The user needs to synchronize the \overline{SR} and \overline{SV} clocks with the CCD signal waveform. The output of the ADC is read out to external circuitry by the ADCCLK signal that is also used internally to control both ADC and PGA operations. It is required that the positive half cycle of the ADCCLK signal always falls in between two adjacent \overline{SV} pulses as shown in Figure 2. The user can then fine tune the ADCCLK timing in relation to the CDS timing to achieve optimal performance.

The TLV987 has direct access to the CDS and PGA internal clocks through the TPP pin and the TPM pin, which may be used to assist timing alignment. See *test register description* paragraph for details.

The \overline{CLAMP} signal is used to activate the input clamping, and the \overline{OBCLP} signal is used to activate auto optical black and offset correction.

input blanking function

During some periods of operation, large input transients may occur at the TLV987 input, which can saturate the input circuits and cause long recovery time. To prevent circuit saturation under such a situation, the TLV987 includes an input blanking function that blocks the input signals by disabling CDS operation whenever the BLKG input is pulled low.

3-wire serial interface

A simple 3-wire (SCLK, SDIN, and \overline{CS}) serial interface is provided to allow writing to the internal registers of the TLV987. The serial clock SCLK can be run at a maximum speed of 40 MHz. The serial data SDIN is 16 bits long. After two leading null bits, there are four address bits for which internal register is to be updated, the following ten bits are the data to be written to the register. To enable the serial port, the \overline{CS} pin must be held low. The data transfer is initiated by the incoming SCLK after \overline{CS} falls.

device reset

When the reset pin (pin 29) is pulled low, all internal registers are set to their default values. The device also resets itself when it is first powered on. In addition, the TLV987 has a software-reset function that resets the device when writing a control bit to the control register.

See *test register description* paragraph for the register default values.

voltage references

An internal precision voltage reference of 1.5 V nominal is provided. This reference voltage is used to generate the ADC Ref– voltage of 1 V and Ref+ voltage of 2 V. All internally-generated voltages are fixed values and cannot be adjusted.

power-down mode (standby)

The TLV987 implements both hardware and software power-down modes. Pulling the \overline{STBY} pin (pin 30) low puts the device in the low-power stand-by mode. Total supply current drops to about 0.6 mA. Setting a power-down control bit in the control register can also activate the power-down mode. The user can still program all internal registers during the power-down mode.



POST OFFICE BOX 655303 • DALLAS, TEXAS 75265

PRINCIPLES OF OPERATION

power supply

The TLV987 has several power supply pins. Each major internal analog block has a dedicated AV_{DD} supply pin. All internal digital circuitry is powered by DV_{DD} . Both AV_{DD} and DV_{DD} are 3 V nominal.

The DIV_{DD} and $DIGND$ pins supply power to the output digital driver (D9–D0). The DIV_{DD} pin is independent of the DV_{DD} pin and can be operated from 1.8 V to 4.4 V. This allows the outputs to interface with digital ASICs requiring different supply voltages.

grounding and decoupling

General practices should apply to the PCB design to limit high frequency transients and noise that are fed back into the supply and reference lines. This requires that the supply and reference pins be sufficiently bypassed. In the case of power supply decoupling, 0.1- μ F ceramic chip capacitors are adequate to keep the impedance low over a wide frequency range. Recommended external decoupling for the three voltage reference pins is shown in Figure 3. Since their effectiveness depends largely on the proximity to the individual supply pin, all decoupling capacitors should be placed as close to the supply pins as possible.

To reduce high frequency and noise coupling, it is highly recommended that the digital ground and analog ground be shorted immediately outside the package. This can be accomplished by running a low impedance line between the $DGND$ and $AGND$ pins, under the package.

automatic optical black and offset correction

In the TLV987, the optical black and system channel offset corrections are performed by an auto digital feedback loop. Two DACs are used to compensate for both channel offset and the optical black offset. A coarse correction DAC (CDAC) is located before the PGA gain stage and a fine correction DAC (FDAC) is located after the gain stage. The digital calibration system is capable of correcting the optical black and channel offset down to one ADC LSB accuracy.

The TLV987 automatically starts auto-calibration whenever the \overline{OBCLP} input is pulled low. The \overline{OBCLP} pulse should be wide enough to cover one positive half cycle of the $ADCCLK$ as shown in Figure 1.

For each line, the optical black pixels plus the channel offset are sampled and converted to digital data by the ADC. A digital circuit averages the data during the optical black pixels. The final averaged result is compared digitally with the desired output code stored in the V_b register (default is 40h), then control logic adjusts the FDAC to make the ADC output equal to the V_b . If the offset is out of the range of the FDAC (± 255 ADC LSBs), the error is corrected by both the CDAC and FDAC. The CDAC increments or decrements by one CDAC LSB depending on whether the offset is negative or positive, until the output is within the range of the FDAC. The remaining residue is corrected by the FDAC.

The relationship among the FDAC, CDAC, and ADC in terms of the number of ADC LSBs is as follows:

$$1 \text{ FDAC LSB} = 1 \text{ ADC LSB,}$$

$$1 \text{ CDAC LSB} = 0.5 \times \text{PGA linear gain} \times 1 \text{ ADC LSB.}$$

For example, if $\text{PGA gain} = 2$ (6 dB), then, $1 \text{ CDAC LSB} = 1 \text{ ADC LSB}$.

After auto-calibration is complete, the ADC digital output during CCD signal interval can be expressed by the following equation:

$$\text{ADC output [D9–D0]} = \text{CCD_input} \times \text{PGA gain} + V_b,$$

Where, V_b is the desired black level selected by the user. The total offset including optical black offset is calibrated to be equal to the V_b by adjusting the offset correction DAC during auto-calibration.

TLV987
3-V 10-BIT 27 MSPS AREA CCD SENSOR
SIGNAL PROCESSOR

SLAS211A – MARCH 1999 – REVISED SEPTEMBER 1999

PRINCIPLES OF OPERATION

The number of black pixels in each line and the number of lines are programmable. The number of black pixels per line that can be averaged is equal to 2^N , where N can be 0, 1, 2, 3, 4, 5, and 6. In addition, if the MP bit is set to 1, then the number of black pixels that are averaged per line will be 3×2^N . The number of lines is equal to 2^L , where L can be 0, 1, 2, 3, 4, 5, 6, 7, and 8.

The auto-calibration feature can be bypassed if the user prefers to directly program the offset DAC registers. Switching from auto-calibration mode to direct programming mode requires two register writes. First, the control bits for the offset DACs in the control register need to be changed, then the desired offset value for the register is loaded into the offset DAC registers for proper error correction. If the total offset including optical black level is less than ± 255 ADC LSBs, only the FDAC needs to be programmed. When switching from the direct programming mode to the auto-calibration mode, the previous DAC register values are used as starting offsets rather than default DAC register values.

A detailed block diagram for internal automatic optical black and offset correction is shown in Figure 5. The timing diagram in Figure 6 illustrates the operation of the calibration system. In the example, the TLV987 is programmed to average four black pixels ($N = 2$) per line for two lines ($L = 1$).



POST OFFICE BOX 655303 • DALLAS, TEXAS 75265

PRINCIPLES OF OPERATION

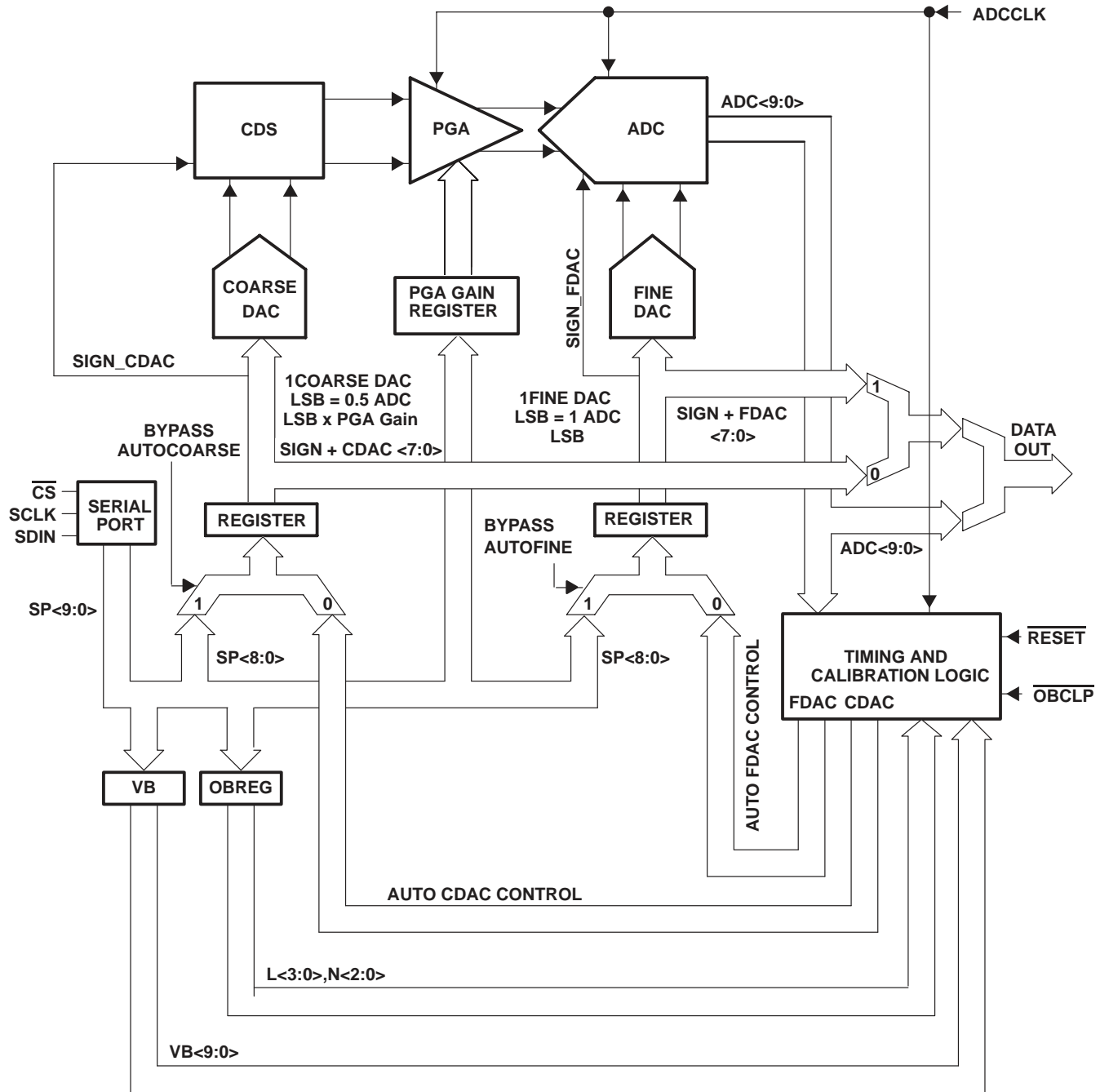

Figure 5. Optical Black and Offset Correction Block Diagram

TLV987
3-V 10-BIT 27 MSPS AREA CCD SENSOR
SIGNAL PROCESSOR

SLAS211A – MARCH 1999 – REVISED SEPTEMBER 1999

PRINCIPLES OF OPERATION

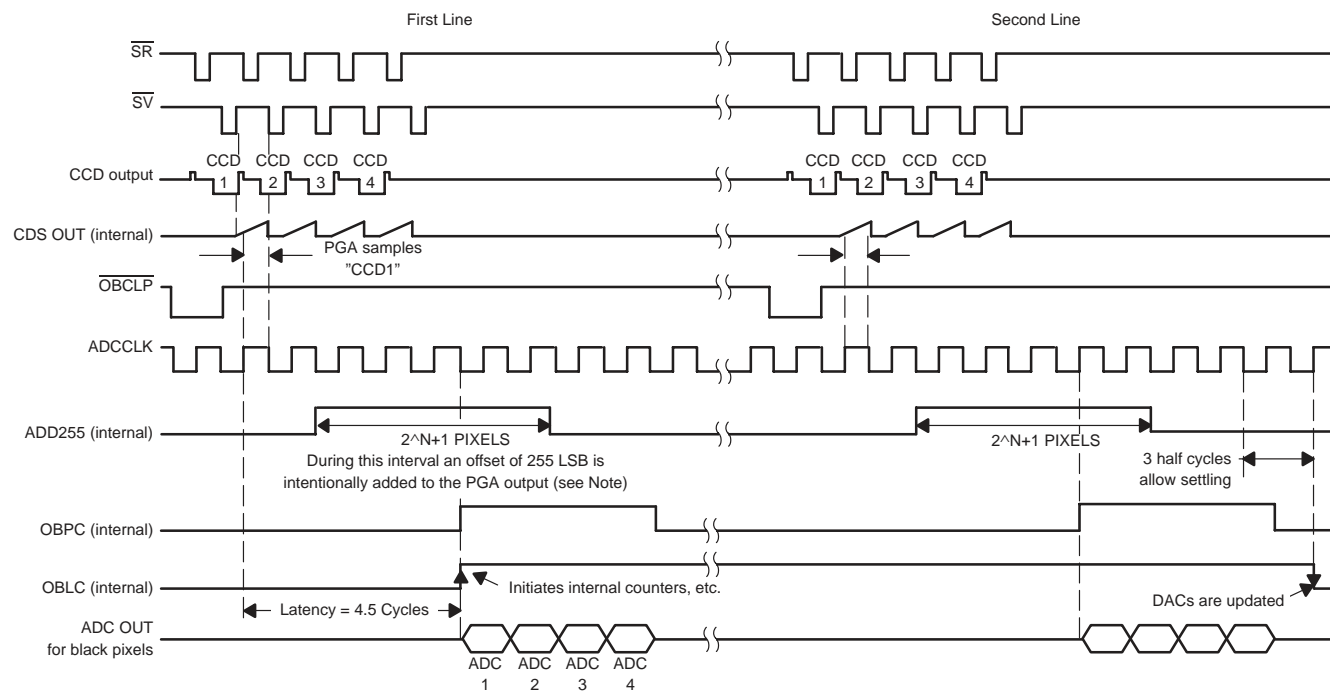

Figure 6. Optical Black and Offset Correction Timing

To avoid the ADC being clipped on differential negative input signals, an internal offset that is equal to 255 ADC LSBs is intentionally added to the PGA output signal. This offset is only added during the optical black pixel interval with a total duration of $2^N + 3$ pixels, where three additional pixels are necessary for accommodating internal latency adjustment.

TLV987
 3-V 10-BIT 27 MSPS AREA CCD SENSOR
 SIGNAL PROCESSOR

SLAS211A – MARCH 1999 – REVISED SEPTEMBER 1999

MECHANICAL DATA

PFB (S-PQFP-G48)

PLASTIC QUAD FLATPACK

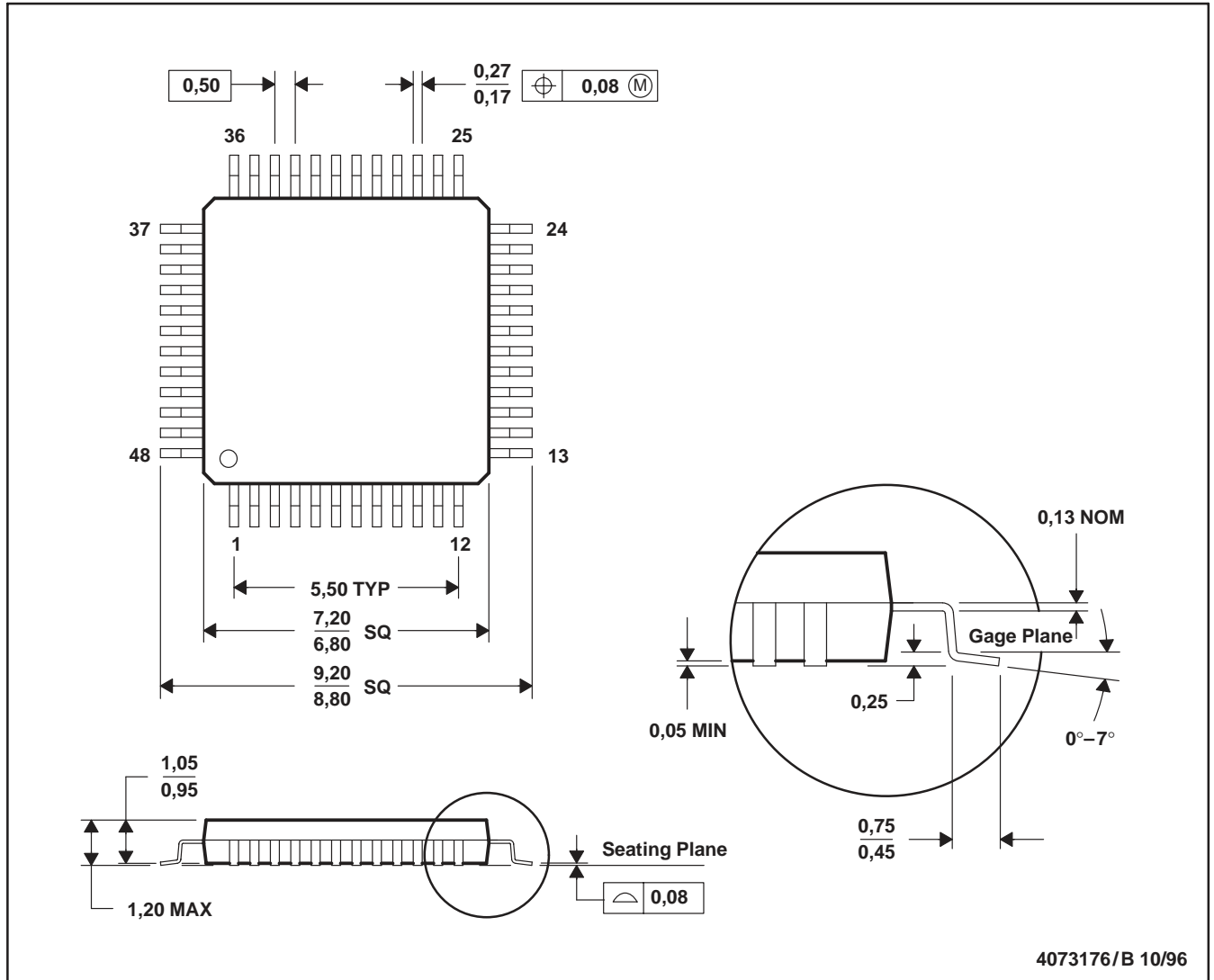

4073176/B 10/96

- NOTES: A. All linear dimensions are in millimeters.
 B. This drawing is subject to change without notice.
 C. Falls within JEDEC MS-026

PACKAGING INFORMATION

Orderable Device	Status ⁽¹⁾	Package Type	Package Drawing	Pins	Package Qty	Eco Plan ⁽²⁾	Lead/Ball Finish	MSL Peak Temp ⁽³⁾
TLV987CPFB	OBSOLETE	TQFP	PFB	48		TBD	Call TI	Call TI

⁽¹⁾ The marketing status values are defined as follows:

ACTIVE: Product device recommended for new designs.

LIFEBUY: TI has announced that the device will be discontinued, and a lifetime-buy period is in effect.

NRND: Not recommended for new designs. Device is in production to support existing customers, but TI does not recommend using this part in a new design.

PREVIEW: Device has been announced but is not in production. Samples may or may not be available.

OBSOLETE: TI has discontinued the production of the device.

⁽²⁾ Eco Plan - The planned eco-friendly classification: Pb-Free (RoHS) or Green (RoHS & no Sb/Br) - please check <http://www.ti.com/productcontent> for the latest availability information and additional product content details.

TBD: The Pb-Free/Green conversion plan has not been defined.

Pb-Free (RoHS): TI's terms "Lead-Free" or "Pb-Free" mean semiconductor products that are compatible with the current RoHS requirements for all 6 substances, including the requirement that lead not exceed 0.1% by weight in homogeneous materials. Where designed to be soldered at high temperatures, TI Pb-Free products are suitable for use in specified lead-free processes.

Green (RoHS & no Sb/Br): TI defines "Green" to mean Pb-Free (RoHS compatible), and free of Bromine (Br) and Antimony (Sb) based flame retardants (Br or Sb do not exceed 0.1% by weight in homogeneous material)

⁽³⁾ MSL, Peak Temp. -- The Moisture Sensitivity Level rating according to the JEDEC industry standard classifications, and peak solder temperature.

Important Information and Disclaimer:The information provided on this page represents TI's knowledge and belief as of the date that it is provided. TI bases its knowledge and belief on information provided by third parties, and makes no representation or warranty as to the accuracy of such information. Efforts are underway to better integrate information from third parties. TI has taken and continues to take reasonable steps to provide representative and accurate information but may not have conducted destructive testing or chemical analysis on incoming materials and chemicals. TI and TI suppliers consider certain information to be proprietary, and thus CAS numbers and other limited information may not be available for release.

In no event shall TI's liability arising out of such information exceed the total purchase price of the TI part(s) at issue in this document sold by TI to Customer on an annual basis.

IMPORTANT NOTICE

Texas Instruments Incorporated and its subsidiaries (TI) reserve the right to make corrections, modifications, enhancements, improvements, and other changes to its products and services at any time and to discontinue any product or service without notice. Customers should obtain the latest relevant information before placing orders and should verify that such information is current and complete. All products are sold subject to TI's terms and conditions of sale supplied at the time of order acknowledgment.

TI warrants performance of its hardware products to the specifications applicable at the time of sale in accordance with TI's standard warranty. Testing and other quality control techniques are used to the extent TI deems necessary to support this warranty. Except where mandated by government requirements, testing of all parameters of each product is not necessarily performed.

TI assumes no liability for applications assistance or customer product design. Customers are responsible for their products and applications using TI components. To minimize the risks associated with customer products and applications, customers should provide adequate design and operating safeguards.

TI does not warrant or represent that any license, either express or implied, is granted under any TI patent right, copyright, mask work right, or other TI intellectual property right relating to any combination, machine, or process in which TI products or services are used. Information published by TI regarding third-party products or services does not constitute a license from TI to use such products or services or a warranty or endorsement thereof. Use of such information may require a license from a third party under the patents or other intellectual property of the third party, or a license from TI under the patents or other intellectual property of TI.

Reproduction of information in TI data books or data sheets is permissible only if reproduction is without alteration and is accompanied by all associated warranties, conditions, limitations, and notices. Reproduction of this information with alteration is an unfair and deceptive business practice. TI is not responsible or liable for such altered documentation.

Resale of TI products or services with statements different from or beyond the parameters stated by TI for that product or service voids all express and any implied warranties for the associated TI product or service and is an unfair and deceptive business practice. TI is not responsible or liable for any such statements.

Following are URLs where you can obtain information on other Texas Instruments products and application solutions:

Products		Applications	
Amplifiers	amplifier.ti.com	Audio	www.ti.com/audio
Data Converters	dataconverter.ti.com	Automotive	www.ti.com/automotive
DSP	dsp.ti.com	Broadband	www.ti.com/broadband
Interface	interface.ti.com	Digital Control	www.ti.com/digitalcontrol
Logic	logic.ti.com	Military	www.ti.com/military
Power Mgmt	power.ti.com	Optical Networking	www.ti.com/opticalnetwork
Microcontrollers	microcontroller.ti.com	Security	www.ti.com/security
		Telephony	www.ti.com/telephony
		Video & Imaging	www.ti.com/video
		Wireless	www.ti.com/wireless

Mailing Address: Texas Instruments
Post Office Box 655303 Dallas, Texas 75265