

PI3USB302-A

3.3V, USB 3.0, 1-Port, 2:1 Mux/DeMux Switch

Features

- 2 Differential Channel, 2:1 Mux/DeMux
- USB 3.0 SuperSpeed Switch
- Bi-directional Operation
- Low Bit-to-Bit Skew, 10 ps max
- 3 dB Bandwidth = 8.1 GHz
- Low channel-to-channel skew: 20 ps max
- Low insertion loss: -1 dB @ 2.5 GHz (5.0 Gbps)
- Low Crosstalk: -33 dB @ 2.5 GHz (5.0 Gbps)
- Low Off Isolation: -27 dB @ 2.5 GHz (5.0 Gbps)
- Low Return Loss: -23.3 dB @ 2.5GHz (5.0Gbps)
- V_{DD} Operating Range: 3.3 V +/-10%
- ESD Tolerance: 2 kV HBM
- Low current: 0.2 mA Typ.
- Totally Lead-Free & Fully RoHS Compliant (Notes 1 & 2)
- Halogen and Antimony Free. “Green” Device (Note 3)
- For automotive applications requiring specific change control (i.e. parts qualified to AEC-Q100/101/200, PPAP capable, and manufactured in IATF 16949 certified facilities), please [contact us](https://www.diodes.com/quality/product-definitions/) or your local Diodes representative.
- Packaging (Pb-free & Green):
 - 20-contact, 2.5 × 4.5mm TQFN (ZB)

Description

Diodes' PI3USB302-A is a 2-differential channel bi-directional multiplexer/demultiplexer switch. Due to its low bit-to-bit skew, high channel-to-channel noise isolation and bandwidth, this product is ideal for USB 3.0 signal switching at 5.0 Gbps.

Application

Routing USB 3.0 SuperSpeed signals

Block Diagram

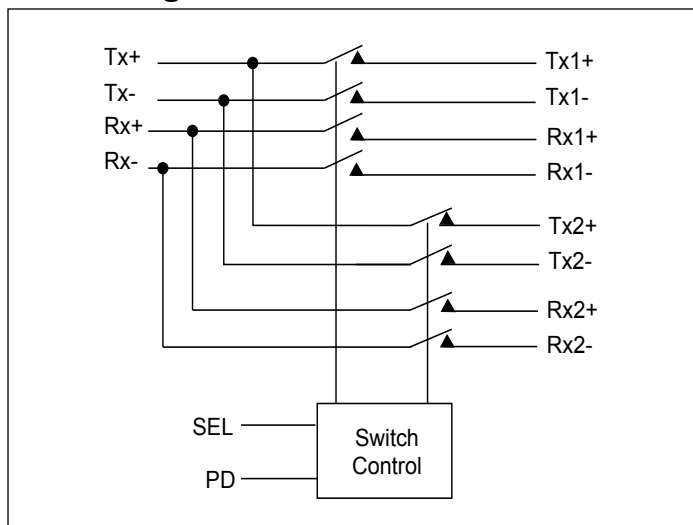

Truth Table

Function	SEL	PD
Port 1 is active	L	L
Port 2 is active	H	L
Both Ports Hi-z, IC power down	x	H

Notes:

1. No purposely added lead. Fully EU Directive 2002/95/EC (RoHS), 2011/65/EU (RoHS 2) & 2015/863/EU (RoHS 3) compliant.
2. See <https://www.diodes.com/quality/lead-free/> for more information about Diodes Incorporated's definitions of Halogen- and Antimony-free, "Green" and Lead-free.
3. Halogen- and Antimony-free "Green" products are defined as those which contain <900ppm bromine, <900ppm chlorine (<1500ppm total Br + Cl) and <1000ppm antimony compounds.

Pin Configuration (Top-side view)

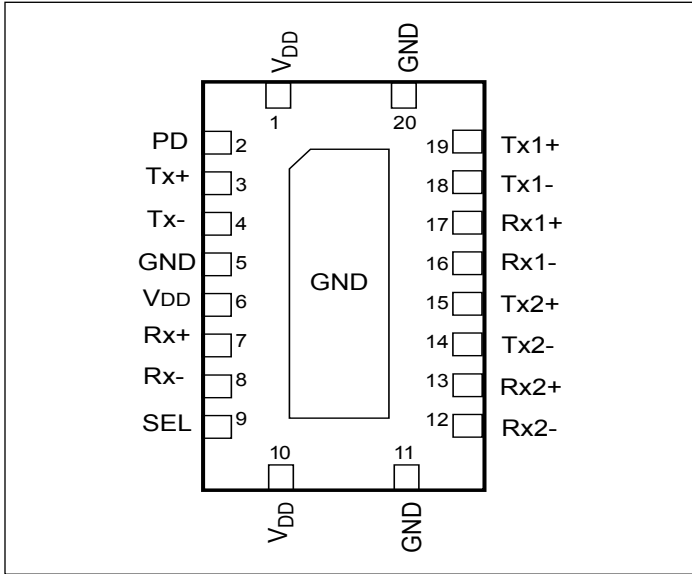

Pin Description

Pin #	Pin Name	I/O	Description
2	PD	I	Power Down input. see truth table on page 1 for functionality
3	Tx+	I/O	Signal I/O, Transmit differential pair from common port
4	Tx-	I/O	
7	Rx+	I/O	Signal I/O, Receive differential pair from common port
8	Rx-		
9	SEL	I	Operation mode Select (when SEL=0: port 1 is active, when SEL=1: port 2 is active)
14	Tx2-	I/O	Signal I/O, Transmit differential pair, port 2
15	Tx2+		
12	Rx2-	I/O	Signal I/O, Receive differential pair, port 2
13	Rx2+		
17	Rx1+	I/O	Signal I/O, Receive differential pair, port 1
16	Rx1-		
19	Tx1+	I/O	Signal I/O, Transmit differential pair, port 1
18	Tx1-		
6, 10, 1	V _{DD}	Pwr	3.3V ±10% Positive Supply Voltage
5, 11, 20, Center Pad	GND	Pwr	Power ground

Maximum Ratings

(Above which useful life may be impaired. For user guidelines, not tested.)

Storage Temperature	-65°C to +150°C
Supply Voltage to Ground Potential	-0.5V to +4.6V
Channel DC Input Voltage	-0.5V to 1.5V
SEL/PD DC Input Voltage	-0.5V to 4.6V
DC Output Current	120mA
Power Dissipation	0.5W

Note:

Stresses greater than those listed under MAXIMUM RATINGS may cause permanent damage to the device. This is a stress rating only and functional operation of the device at these or any other conditions above those indicated in the operational sections of this specification is not implied. Exposure to absolute maximum rating conditions for extended periods may affect reliability.

Electrical Characteristics

Recommended Operating Conditions

Symbol	Parameter	Conditions	Min	Typ	Max	Units
V _{DD}	3.3V Power Supply		3.0	3.3	3.6	V
I _{DD}	Total current from V _{DD} 3.3V supply	SEL = 0V or V _{DD} ,		0.2	1	mA
I _{DD_PD}	Power down current	PD = 1		20	40	µA
T _{CASE}	Case temperature range for operation within spec.		-40		85	°C
T _j	Junction Temperature	Absolute			125	°C
		Operating			85	

DC Electrical Characteristics for Switching over Operating Range

Parameters	Description	Test Conditions ⁽¹⁾	Min	Typ ⁽¹⁾	Max	Units
V _{IH-SEL, PD}	Input HIGH Voltage, SEL, PD Input		2		3.6	V
V _{IL-SEL, PD}	Input LOW Voltage, SEL, PD Input		0		0.8	
V _{IK}	Clamp Diode Voltage	V _{DD} = Max, I _{IN} = -18mA		-0.7	-1.2	
I _{IH}	Input HIGH Current SEL, PD Input	V _{DD} = Max, V _{IN} = V _{DD}	-5		+5	µA
I _{IL}	Input LOW Current, SEL, PD Input	V _{DD} = Max, V _{IN} = 0V	-5		+5	
I _{IH}	Input High Current, T _X , R _X	V _{DD} = Max, V _{IN} = 1.5V	-10		+10	
I _{IL}	Input LOW Current, T _X , R _X	V _{DD} = Max, V _{IN} = 0V	-10		+10	
I _{OZH}	High Z HIGH Current, T _X , R _X	V _{DD} = Max, V _{IN} = 1.5V	-10		+10	µA
I _{OZL}	High Z LOW Current, T _X , R _X	V _{DD} = Max, V _{IN} = 0V	-10		+10	µA

Note:

1. Typical values are at V_{DD} = 3.3V, T_A = 25°C ambient and maximum loading.

Switching Characteristics

Parameters	Description	Test Conditions	Min.	Typ.	Max.	Units
t _{PZH} , t _{PZL}	Line Enable Time			25	30	ns
t _{PHZ} , t _{PLZ}	Line Disable Time			5	25	
t _{b-b}	Bit-to-bit skew within the same differential pair			5	10	ps
t _{ch-ch}	Channel-to-channel skew				20	

Dynamic Electrical Characteristics

Parameter	Description	Test Conditions	Min.	Typ. ⁽¹⁾	Max.	Units
DDIL ^(2,3)	Differential Insertion Loss ($V_{IN} = -10\text{dBm}$, $DC = 0V$)	$f = 100\text{MHz}$ $f = 1.25\text{GHz}$ $f = 2.5\text{GHz}$ $f = 4.0\text{GHz}$		-0.4 -0.6 -1.0 -1.7		dB
DDILOFF ^(2,3)	Differential Off Isolation	$f = 100\text{MHz}$ $f = 1.25\text{GHz}$ $f = 2.5\text{GHz}$ $f = 4.0\text{GHz}$		-59 -37 -27 -21		dB
DDRL ⁽²⁾	Differential Return Loss	$f = 100\text{MHz}$ $f = 1.25\text{GHz}$ $f = 2.5\text{GHz}$ $f = 4.0\text{GHz}$		-27 -23.3 -23.3 -13.5		dB
DDNEXT ^(2,3)	Near End Crosstalk	$f = 100\text{MHz}$ $f = 1.25\text{GHz}$ $f = 2.5\text{GHz}$ $f = 4.0\text{GHz}$		-57 -38 -33 -32		dB
BW	-3dB Bandwidth			8.1		GHz

Notes:

1. Guaranteed by design. Typical values are at $V_{DD} = 3.3V$, $T_A = 25^\circ\text{C}$ ambient and maximum loading.
2. S parameters are measured with our evaluation board made with Rogers (R04350) material. Trace width is 30 mil, length 540 mil, trace impedance is $50\ \Omega$ (+/- 5%) and total insertion loss of the trace is 0.5dB@4GHz.
3. Measurement done with fixture embedding.

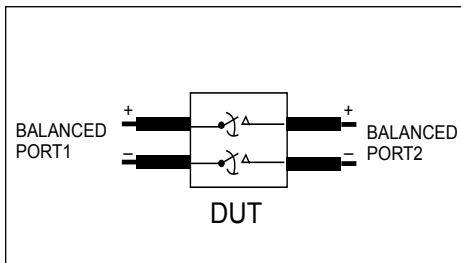

Differential Insertion Loss and Return Test Circuit

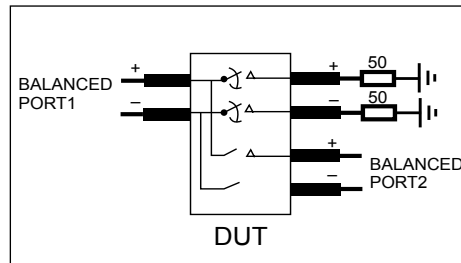

Differential Off Isolation Test Circuit

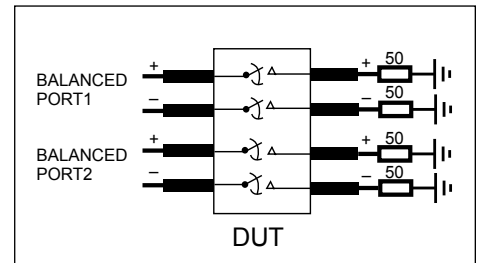

Differential Near End Xtalk Test Circuit

PI3USB302-A

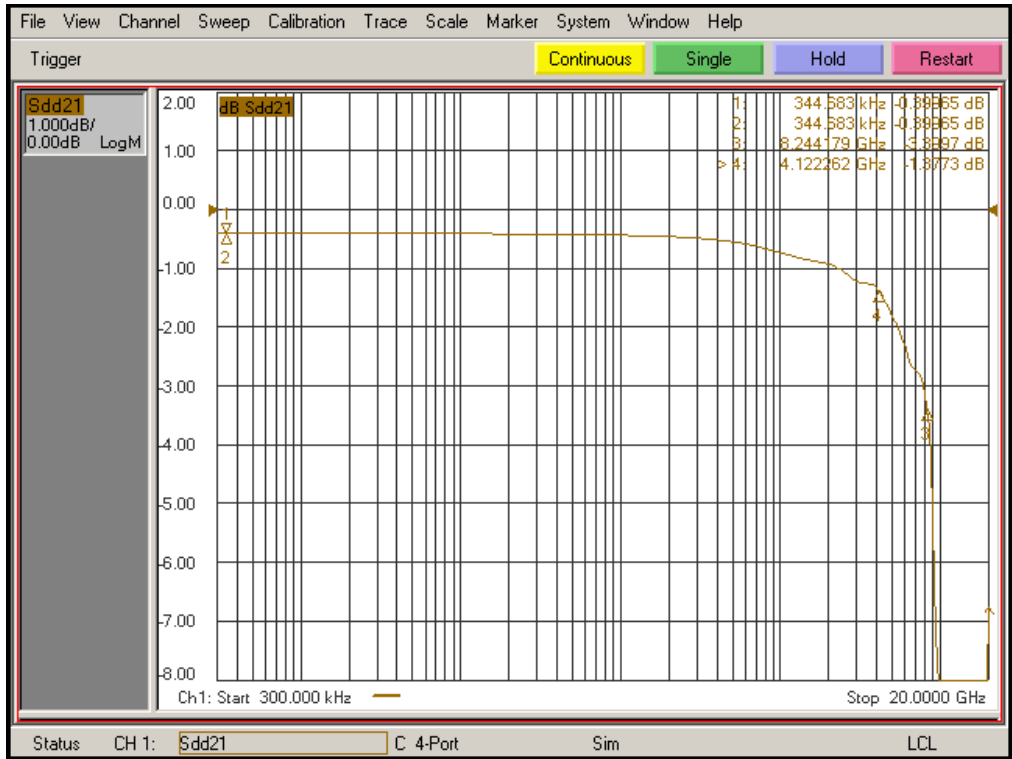

Differential Insertion Loss

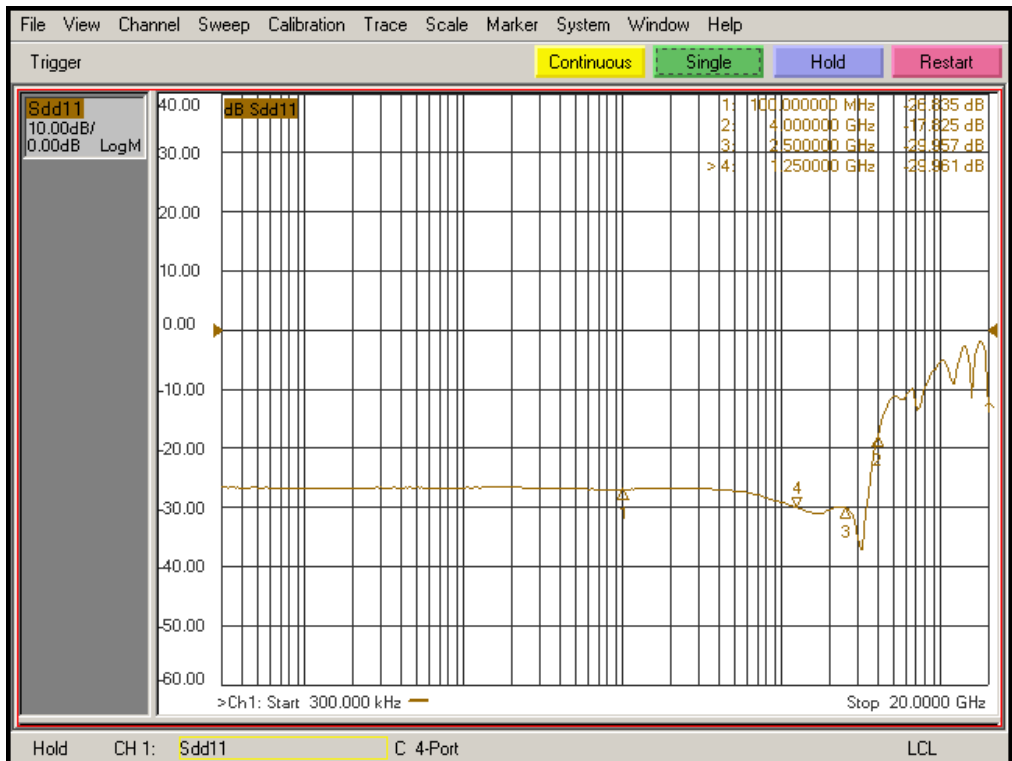

Differential Return Loss

PI3USB302-A

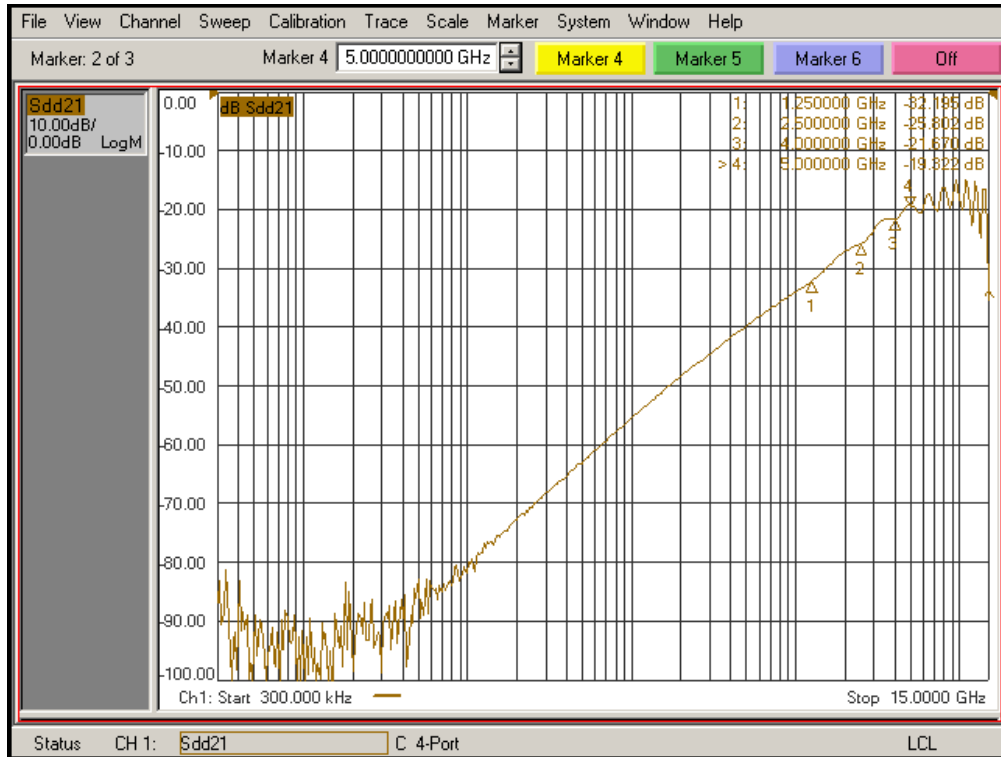

Differential Off Isolation

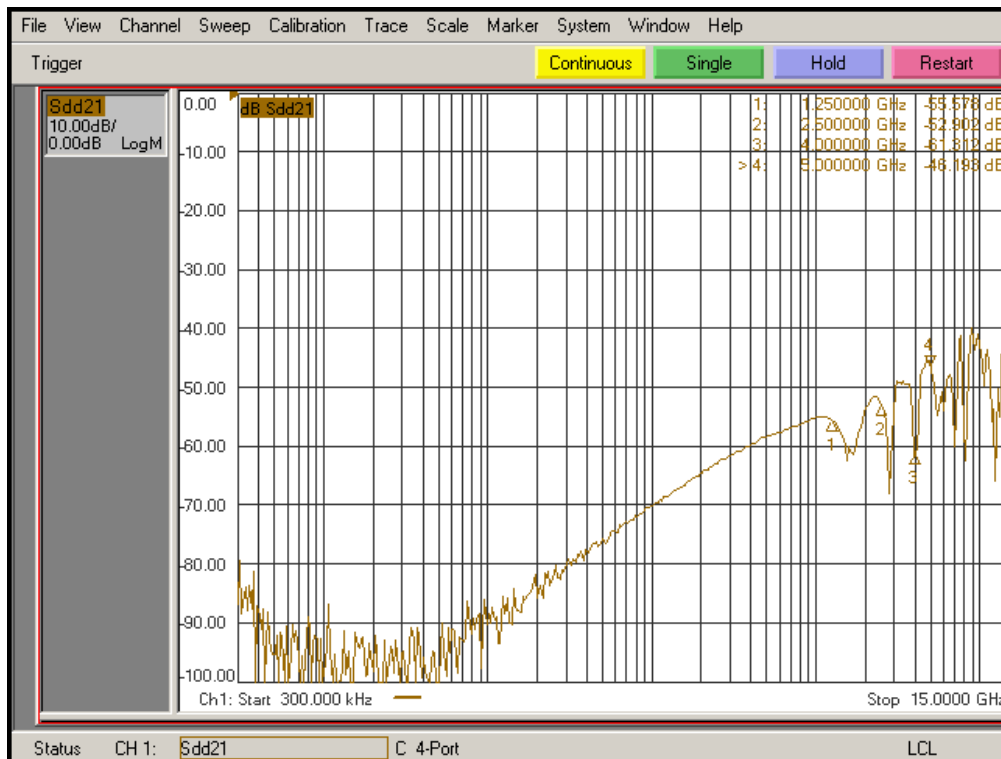

Differential Crosstalk

PI3USB302-A

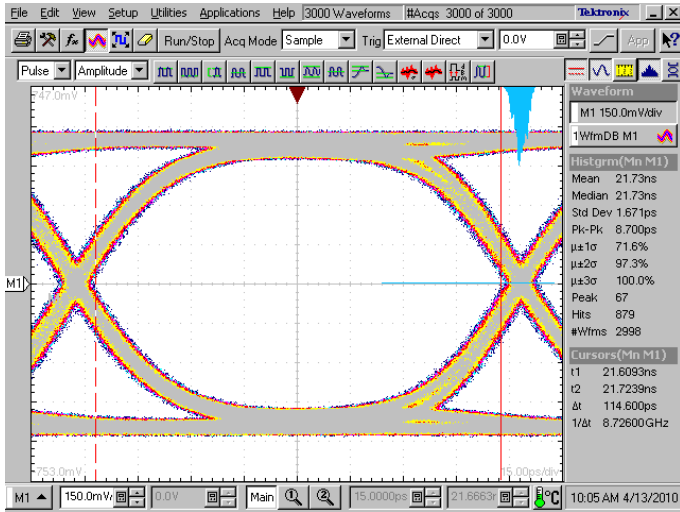

5.0 Gbps RX signal eye without PI3USB302-A

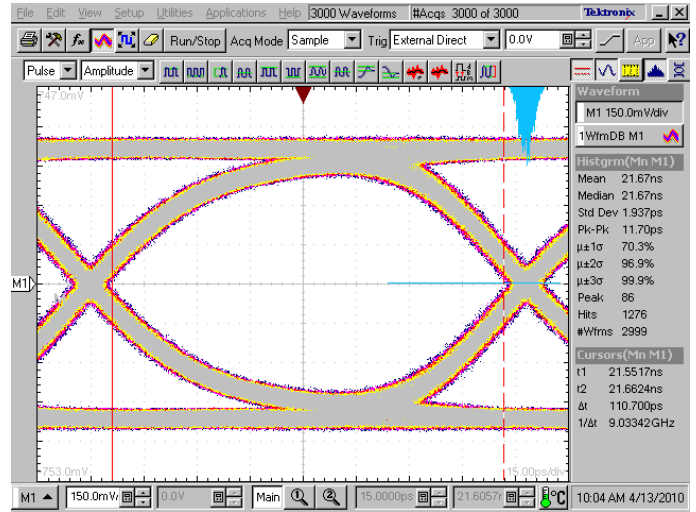

5.0 Gbps RX signal eye with PI3USB302-A

Test Circuit for Electrical Characteristics

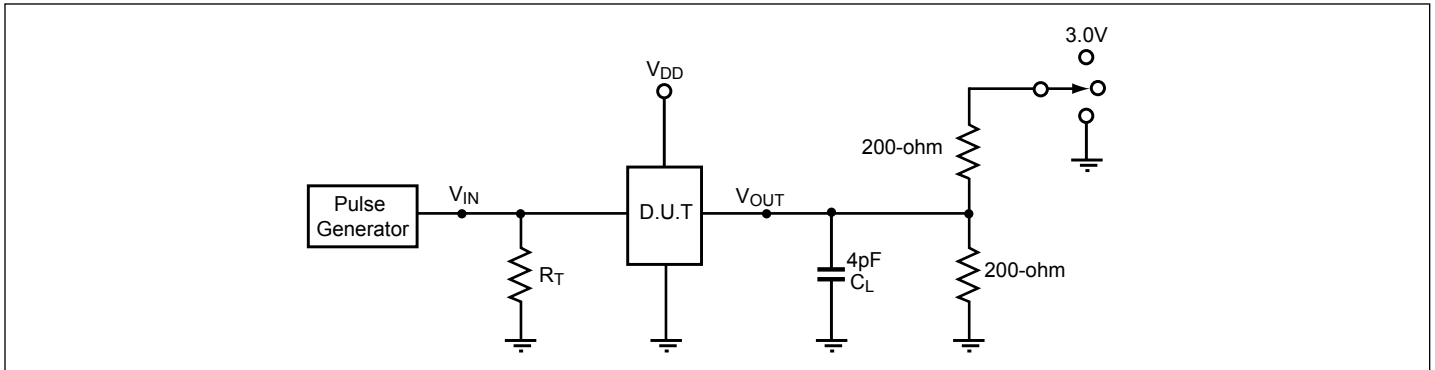

Switch Positions

Test	Switch
t _{PLZ} , t _{PZL}	3.0V
t _{PHZ} , t _{PZH}	GND
Prop Delay	Open

Switching Waveforms

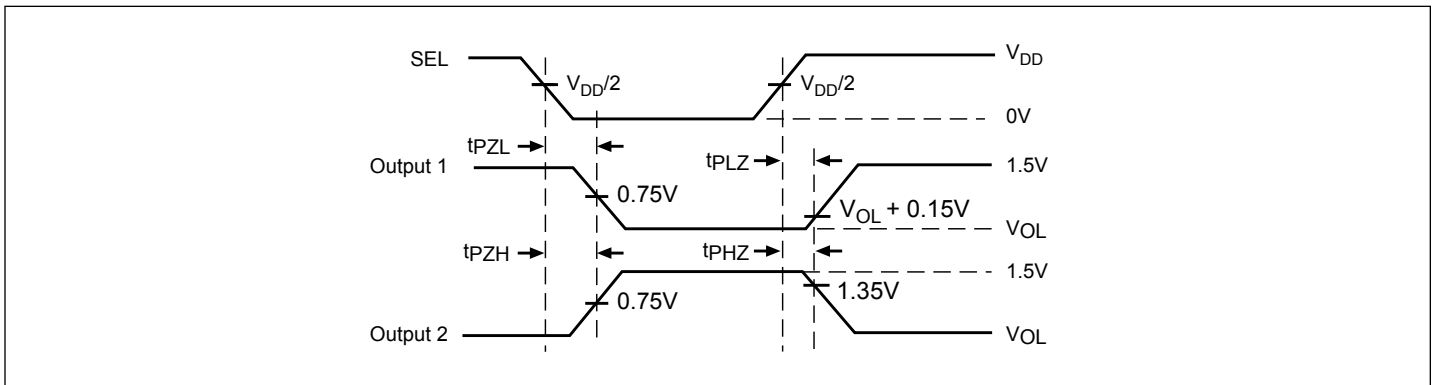

Voltage Waveforms Enable and Disable Times

Part Marking

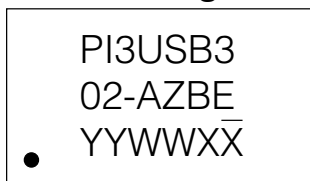

YY: Year
 WW: Workweek
 1st X: Assembly Code
 2nd X: Fab Code

Packaging Mechanical: 20-TQFN (ZB)

SYMBOLS	MIN.	NOM.	MAX.
A	---	---	1.00
A1	0.00	0.02	0.05
A3	0.20 REF.		
b	0.18	0.25	0.30
D	2.40	2.50	2.60
E	4.40	4.50	4.60
e	0.50 BSC		
L	0.30	0.40	0.50
K	0.20	---	---
D2	0.90	1.00	1.10
E2	2.90	3.00	3.10

NOTE:

- ALL DIMENSIONS ARE IN mm. ANGLES IN DEGREES.
- COPLANARITY APPLIES TO THE EXPOSED THERMAL PAD AS WELL AS THE TERMINALS.
- REFER JEDEC MO-241
- RECOMMENDED LAND PATTERN IS FOR REFERENCE ONLY.
- THERMAL PAD SOLDERING AREA (MESH STENCIL DESIGN IS RECOMMENDED).

14-0265

DATE: 10/20/14

PERICOM
Enabling Serial Connectivity

DESCRIPTION: 20-Contact, Very Thin Quad Flat No-Lead (TQFN)

PACKAGE CODE: ZB (ZB20)

DOCUMENT CONTROL #: PD-2104

REVISION: B

For latest package info.

please check: <http://www.diodes.com/design/support/packaging/pericom-packaging/packaging-mechanicals-and-thermal-characteristics/>

Ordering Information

Ordering Code	Package Code	Package Description
PI3USB302-AZBEX	ZB	20-Contact, Very Thin Quad Flat No-Lead (TQFN)

Notes:

- No purposely added lead. Fully EU Directive 2002/95/EC (RoHS), 2011/65/EU (RoHS 2) & 2015/863/EU (RoHS 3) compliant.
- See <https://www.diodes.com/quality/lead-free/> for more information about Diodes Incorporated's definitions of Halogen- and Antimony-free, "Green" and Lead-free.
- Halogen- and Antimony-free "Green" products are defined as those which contain <900ppm bromine, <900ppm chlorine (<1500ppm total Br + Cl) and <1000ppm antimony compounds.
- E = Pb-free and Green
- X suffix = Tape/Reel

IMPORTANT NOTICE

1. DIODES INCORPORATED AND ITS SUBSIDIARIES (“DIODES”) MAKE NO WARRANTY OF ANY KIND, EXPRESS OR IMPLIED, WITH REGARDS TO ANY INFORMATION CONTAINED IN THIS DOCUMENT, INCLUDING, BUT NOT LIMITED TO, THE IMPLIED WARRANTIES OF MERCHANTABILITY, FITNESS FOR A PARTICULAR PURPOSE OR NON-INFRINGEMENT OF THIRD PARTY INTELLECTUAL PROPERTY RIGHTS (AND THEIR EQUIVALENTS UNDER THE LAWS OF ANY JURISDICTION).

2. The Information contained herein is for informational purpose only and is provided only to illustrate the operation of Diodes products described herein and application examples. Diodes does not assume any liability arising out of the application or use of this document or any product described herein. This document is intended for skilled and technically trained engineering customers and users who design with Diodes products. Diodes products may be used to facilitate safety-related applications; however, in all instances customers and users are responsible for (a) selecting the appropriate Diodes products for their applications, (b) evaluating the suitability of the Diodes products for their intended applications, (c) ensuring their applications, which incorporate Diodes products, comply the applicable legal and regulatory requirements as well as safety and functional-safety related standards, and (d) ensuring they design with appropriate safeguards (including testing, validation, quality control techniques, redundancy, malfunction prevention, and appropriate treatment for aging degradation) to minimize the risks associated with their applications.

3. Diodes assumes no liability for any application-related information, support, assistance or feedback that may be provided by Diodes from time to time. Any customer or user of this document or products described herein will assume all risks and liabilities associated with such use, and will hold Diodes and all companies whose products are represented herein or on Diodes’ websites, harmless against all damages and liabilities.

4. Products described herein may be covered by one or more United States, international or foreign patents and pending patent applications. Product names and markings noted herein may also be covered by one or more United States, international or foreign trademarks and trademark applications. Diodes does not convey any license under any of its intellectual property rights or the rights of any third parties (including third parties whose products and services may be described in this document or on Diodes’ website) under this document.

5. Diodes products are provided subject to Diodes’ Standard Terms and Conditions of Sale (<https://www.diodes.com/about/company/terms-and-conditions/terms-and-conditions-of-sales/>) or other applicable terms. This document does not alter or expand the applicable warranties provided by Diodes. Diodes does not warrant or accept any liability whatsoever in respect of any products purchased through unauthorized sales channel.

6. Diodes products and technology may not be used for or incorporated into any products or systems whose manufacture, use or sale is prohibited under any applicable laws and regulations. Should customers or users use Diodes products in contravention of any applicable laws or regulations, or for any unintended or unauthorized application, customers and users will (a) be solely responsible for any damages, losses or penalties arising in connection therewith or as a result thereof, and (b) indemnify and hold Diodes and its representatives and agents harmless against any and all claims, damages, expenses, and attorney fees arising out of, directly or indirectly, any claim relating to any noncompliance with the applicable laws and regulations, as well as any unintended or unauthorized application.

7. While efforts have been made to ensure the information contained in this document is accurate, complete and current, it may contain technical inaccuracies, omissions and typographical errors. Diodes does not warrant that information contained in this document is error-free and Diodes is under no obligation to update or otherwise correct this information. Notwithstanding the foregoing, Diodes reserves the right to make modifications, enhancements, improvements, corrections or other changes without further notice to this document and any product described herein. This document is written in English but may be translated into multiple languages for reference. Only the English version of this document is the final and determinative format released by Diodes.

8. Any unauthorized copying, modification, distribution, transmission, display or other use of this document (or any portion hereof) is prohibited. Diodes assumes no responsibility for any losses incurred by the customers or users or any third parties arising from any such unauthorized use.

Copyright © 2021 Diodes Incorporated

www.diodes.com