

REV.	DATE	ECR NO.	DESCRIPTION
NC	12/12/05	-	INITIAL RELEASE
A	06/18/08	-	CORRECT PART NUMBER CALLOUT ITEM NO.2

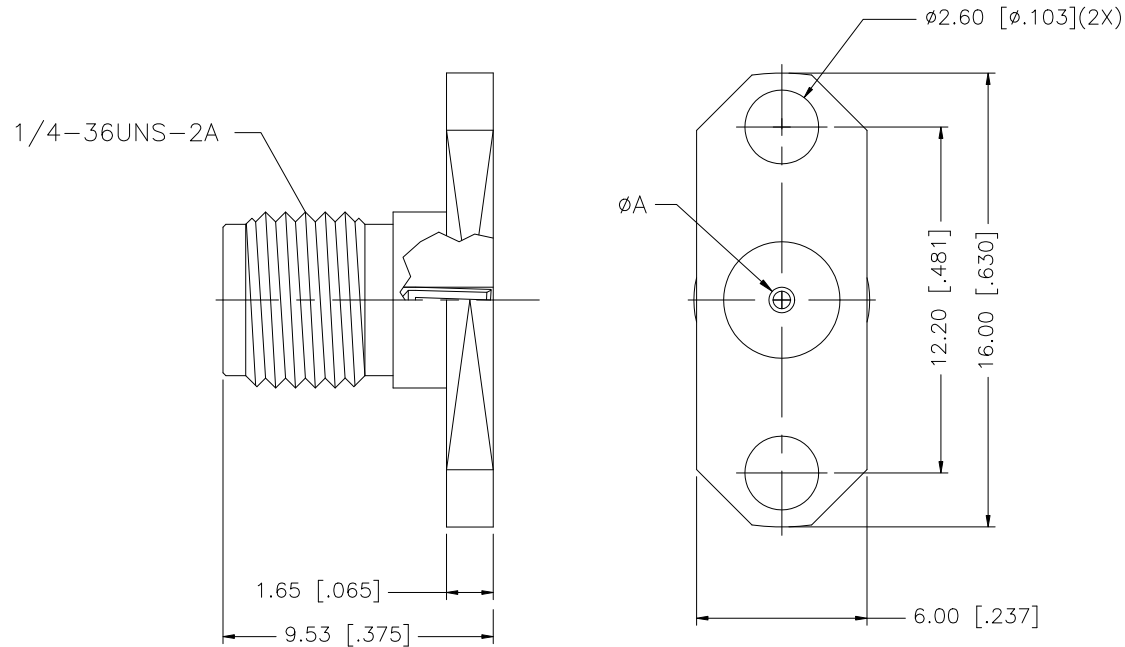

ITEM NO.	DRAWING NO.	A
1.	132163	.30 [.012"]
2.	132163-10	.38 [.015"]
3.	132163-11	.46 [.018"]
4.	132163-12	.91 [.036"]

8					<small>UNLESS OTHERWISE SPECIFIED DIMENSIONS ARE IN MILLIMETERS. DIMENSIONS IN [] ARE IN INCHES AND FOR CUSTOMER REFERENCE ONLY.</small> <small>UNLESS OTHERWISE SPECIFIED TOLERANCES FOR MILLIMETERS ARE:</small> 0.5 - 8mm \pm 0.20mm 8 - 30mm \pm 0.40mm 30 - 120mm \pm 0.50mm <small>UNLESS OTHERWISE SPECIFIED TOLERANCES FOR INCHES ARE:</small> .020 - .315 = \pm 0.007" .315 - 1.180 = \pm 0.015" 1.180 - 4.724 = \pm 0.020"	APPROVALS	DATE	<h1 style="color: blue;">Amphenol Connex</h1>				
7						DRAWN	G.R.S.					06/18/08
6						CHECKED			PART NO. 132163			
5						ISSUED						
4						SHEET	1 OF 1		REV. A SIZE A SCALE NA			
3	CONTACT PIN	BER. COPPER	GOLD	1	DO NOT SCALE DRAWING			C:/132/132163.DWG				
2	INSULATOR	TEFLON	NATURAL	1								
1	BODY	BRASS	GOLD	1								
	DESCRIPTION	MATERIAL	FINISH	QTY								