

TDINV1000P100: 1.0 kW Inverter Evaluation Board

Introduction

The TDINV1000P100 1.0kW inverter kit provides an easy way to evaluate the performance advantages of GaN power FETs in various inverter applications, such as solar and uninterruptible power supplies (UPS). The kit provides the main features of a single-phase inverter in a proven, functional configuration, operating at or above 100kHz. At the core of the inverter are four TPH3206PSB 180mΩ GaN FETs configured as a full bridge. These are tightly coupled to gate-drive circuits on a board which also includes flexible microcontroller options and convenient communication connection to a PC. The switch-mode power signals are filtered to provide a pure sinusoidal output. For more information and the complete design files, please visit <https://www.transphormusa.com/en/evaluation-kit/tdinv1000p100-kit/>.

The TDINV1000P100 -KIT is for evaluation purposes only.



Figure 1. TDINV1000P100 inverter evaluation board

Warning



This evaluation board is intended to demonstrate GaN FET technology and is for demonstration purposes only and no guarantees are made for standards compliance.

There are areas of this evaluation board that have exposed access to hazardous high voltage levels. Exercise caution to avoid contact with those voltages. Also note that the evaluation board may retain high voltage temporarily after input power has been removed. Exercise caution when handling.

When testing converters on an evaluation board, ensure adequate cooling. Apply cooling air with a fan blowing across the converter or across a heatsink attached to the converter. Monitor the converter temperature to ensure it does not exceed the maximum rated per the datasheet specification.

TDINV1000P100 User Guide

The control portion of the circuit is designed around the popular C2000™ family of microcontrollers from Texas Instruments (TI). The source code is available along with related support information directly from TI. In addition to this general resource, Transphorm provides original firmware which comes loaded in flash on the microcontroller. The source code, configured as a complete project, is available at <https://www.transphormusa.com/en/evaluation-kit/tdinv1000p100-kit/>. This project is a convenient starting point for further developments. The microcontroller itself resides on a small, removable control card, supplied by TI, so that different C2000 devices may be used if desired. The schematic for the TDINV1000P100 circuit board is provided at the end of this user guide document, as well in the [design files](#).

The TDINV1000P100 -KIT includes:

- TDINV1000P100 single-phase inverter assembly
- Texas Instruments F28035ISO control card
- 9V power supply with U.S. adaptor

Complete design files, firmware files and support documentation can be found online at <https://www.transphormusa.com/en/evaluation-kit/tdinv1000p100-kit/>.

TDINV1000P100 input/output specifications

- High-voltage input: **420V_{DC} max**
- Auxiliary supply (J1): **9V_{CC}**
- Input Voltage: **0V_{DC} - 420V_{DC}**
- Output Voltage: **V_{DC} / $\sqrt{2}$ V_{RMS} at 50/60Hz¹, up to 1000W**
- PWM frequency: **50kHz - 150kHz²**
- Power dissipation in the GaN FET is limited by the maximum junction temperature. Refer to the TPH3206PSB datasheet

¹ The output frequency may be changed in the software; as delivered it is 60Hz

² The switching frequency may be changed in the software; as delivered it is 100kHz

Circuit description

Refer to Figure 2 for a block diagram of the inverter circuit. A detailed schematic is available in the [design files](#).

The TDINV1000P100 inverter is a simple full-bridge inverter. Two GaN half-bridges are driven with pulse-width modulated (PWM) command signals to create the sinusoidal varying output. The output filter largely removes the switching frequency, leaving the 50/60Hz fundamental sinusoid. The high-frequency (100kHz+) PWM signals are generated by the TI microcontroller and connected directly to high speed, high voltage gate drivers. A connection for external communication to the microcontroller is provided by an isolated USB interface. Except for the high-voltage supply for the power stage, all required voltages for the control circuitry are derived from one 9V input.

TDINV1000P100 User Guide

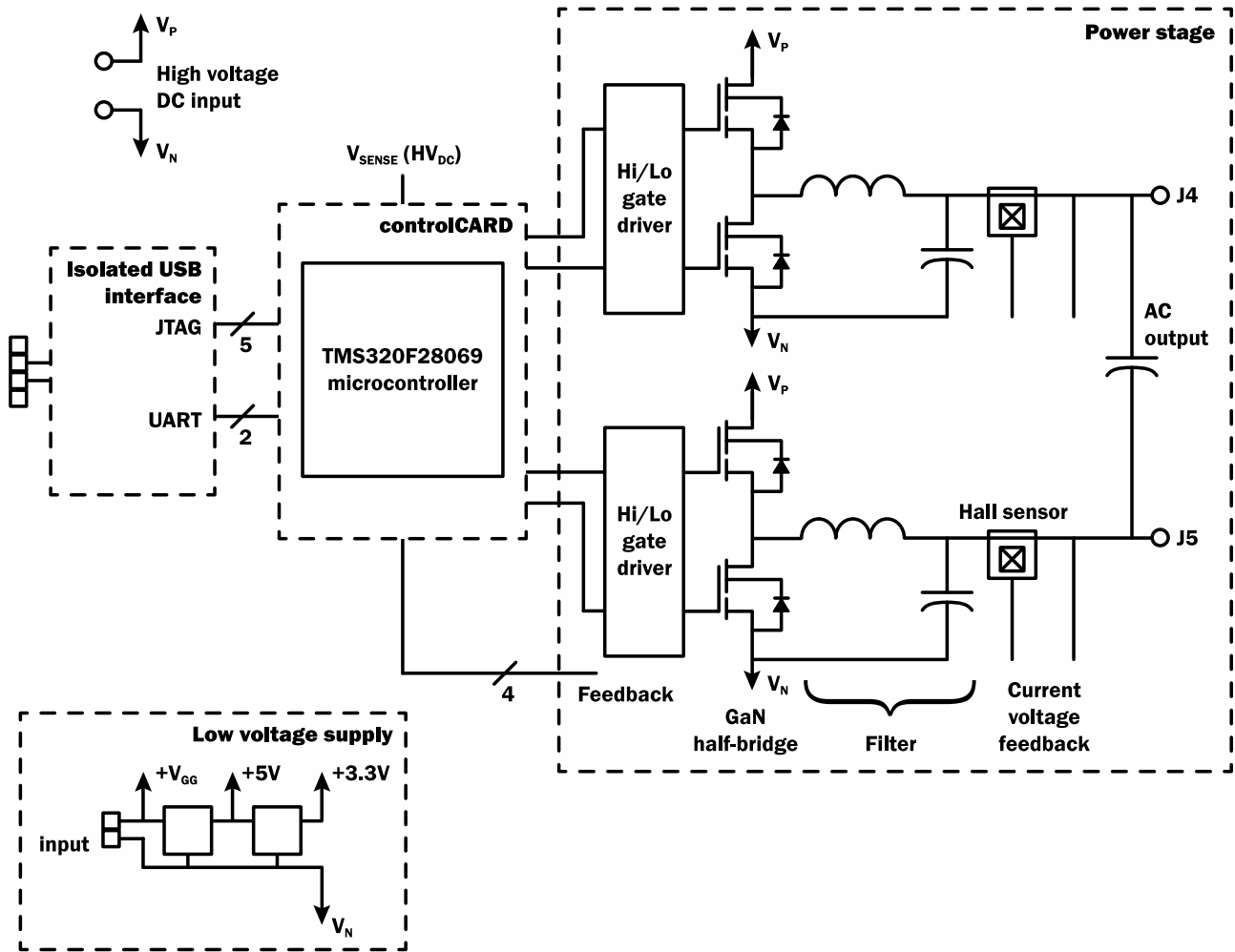

Figure 2. Circuit block diagram

The inverter takes advantage of diode-free operation, in which the freewheeling current is carried by the GaN FETs themselves due to their bi-directional capability, without the need of additional freewheeling diodes. For minimum conduction loss, the gates of the FETs are enhanced while they carry the freewheeling current. The high and low-side V_{GS} waveforms are therefore pairs of non-overlapping pulses, as illustrated in Figure 3 below.

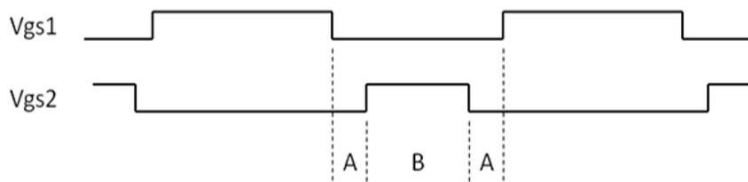

Figure 3. Non-overlapping gate-drive pulse; A is a dead time set in the firmware

Gate drivers

High-voltage integrated drivers supply the gate-drive signals for the high and low-side GaN FETs. These are 2500V isolation drivers (Silicon Labs Si827x family), specifically chosen for high-speed operation without automatic dead time insertion. The dead time between turn-off of one GaN FET in a half-bridge and turn-on of its mate is set in the firmware.

TDINV1000P100 User Guide

Dead time control

The required form of the gate-drive signals is shown in Figure 3. The times marked A are the dead times when neither transistor is driven on. The dead time must be greater than zero to avoid shoot-through currents. The Si827x gate drive chip does not have a DT control. Dead time is controlled by firmware. The default dead time for TDINV1000P100 is 120ns. See the firmware guide for instructions to modify the dead time control.

Output filter

A simple filter on the output (L1, L2) attenuates the switching frequency, producing a clean sinusoidal waveform for output connections in terminals J4 and J5. The filter inductors and capacitors used on the demo board were chosen to provide the optional combination of benefits: low loss, good attenuation of the switching frequency, and small size. Consult the schematic and/or bill of materials to verify values; but in general, the cutoff frequency will be around 5kHz - 10kHz to accommodate 100Hz switching. The inductors have powder cores with relatively low permeability (60-90) and soft saturation characteristics. The inductors and/or capacitors can be changed to evaluate different filter designs.

Current sensing

Hall sensors U5 and U6 provide linear current feedback to the microcontroller. These signals are used to control output power flow, to protect against over current. Note that these are placed at an intermediate point of the output filter. Refer to the bill of materials on page 7 to confirm the sensor part numbers, but typical would be the Allegro **ACS723-20A** sensor, which has a $\pm 40A$ range (100mV/A). These parts are pin-compatible with a $\pm 5A$ and $\pm 30A$ versions of ACS723, should lower ranges be desired. Note also that resistor dividers scale the 5V outputs for the 3V range of the A/D.

Communication

Communication between the microcontroller and a computer is accomplished with a mini USB cable to a JTAG microcontroller interface.

Control card

The microcontroller resides on a removable card, which inserts in a DIM100 socket on the inverter PCB. The socket can accept many of the C2000 series control cards from Texas Instruments. The TMDSCNCD28035ISO Piccolo control card supplied with the kit provides capability to experiment with a wide variety of modulation and control algorithms. It comes loaded with firmware to allow immediate, out-of-the-box, operation. Should the user wish to use an alternative microcontroller family, an appropriate control card can be designed to insert into the DIM100 socket.

Heatsink

The two TO-220 GaN FETs on each half-bridge are mounted on a common heatsink. The heatsink is adequate for 1000W operation with forced air flow. Even higher efficiency at high power may be achieved by minimizing the temperature rise. This may be accomplished with stronger airflow. Alternately the heatsinks could be replaced with larger and more effective ones.

TDINV1000P100 User Guide

Connections

Power for the AC output is derived from the high-voltage DC input. This will typically be a DC power supply with output voltage up to 420V_{DC}. A 22 μ F, low ESR film capacitor is provided as a bypass capacitor for the high voltage supply, along with several lower valued ceramic capacitors in parallel. This is not intended to provide significant energy storage. It is assumed that the power supply or preceding DC-DC stage contains adequate output capacitance.

The control, communication, and gate-drive circuits are all powered from a single 9V input (V_{CC}). The wall-plug adaptor provided generates the appropriate voltage (typically 9V) and power level.

Note that all signals on the board are referenced to the negative terminals of the high and low voltage supplies, which are tied together on the PCB. The heatsinks are also connected to the negative terminals of the supplies.

Powering on the board

- Refer to Figure 4. Insert the microcontroller card to the DIM100 socket before applying any power to the board.
- Before turning on the supply, connect the high-voltage power supply to the +/- inputs (J2 and J3). **DO NOT apply too much force to the J2 and J3 connectors, as excessive force may bend and/or crack the PCB.**
- If a load is to be used, connect the load to the output terminals (J4 and J5). **DO NOT apply too much force to the J4 and J5 connectors, as excessive force may bend and/or crack the PCB.**
- Insert the V_{CC} (9V) plug to jack J1. LED1 should illuminate, indicating power is applied to the 5V and 3.3V regulators. Depending on the specific control card used, one or more LEDs on the control card will also illuminate, indicating power is applied. A flashing LED indicates the firmware is executing.
- To use the pre-loaded firmware, no computer connection is required. If a computer connection is required for code modification, connect the USB cable from the computer to the USB connector on the microcontroller.
- Turn on the high-voltage power. The high-voltage supply may be raised gradually.

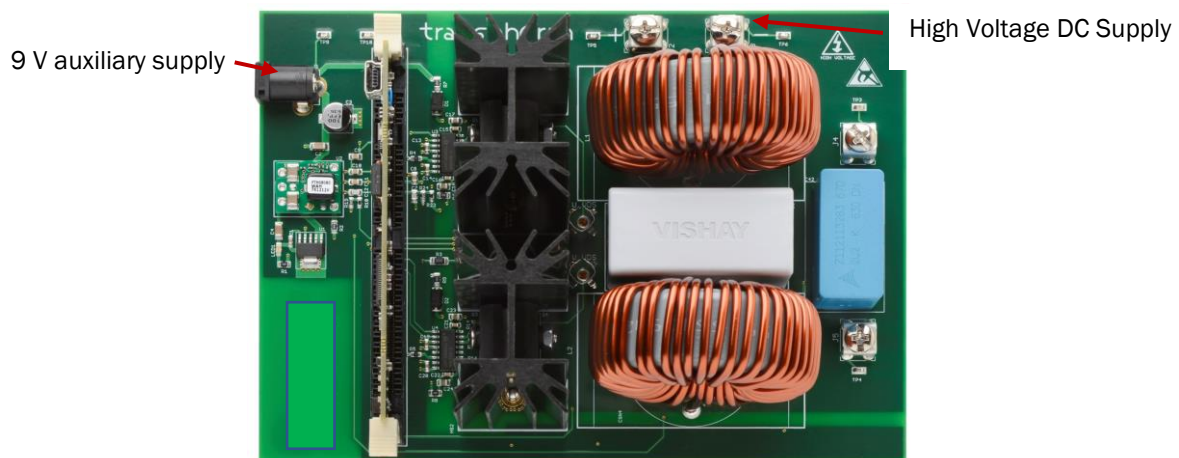

Figure 4. Connections

Powering off the board

1. Switch off high-voltage DC supply
2. Power off 9V aux supply

TDINV1000P100 User Guide

Test overview

Figure 5 shows typical waveforms. The negative terminal of the high-voltage supply is a convenient reference for the oscilloscope measurements, provided there are not multiple connections to earth ground.

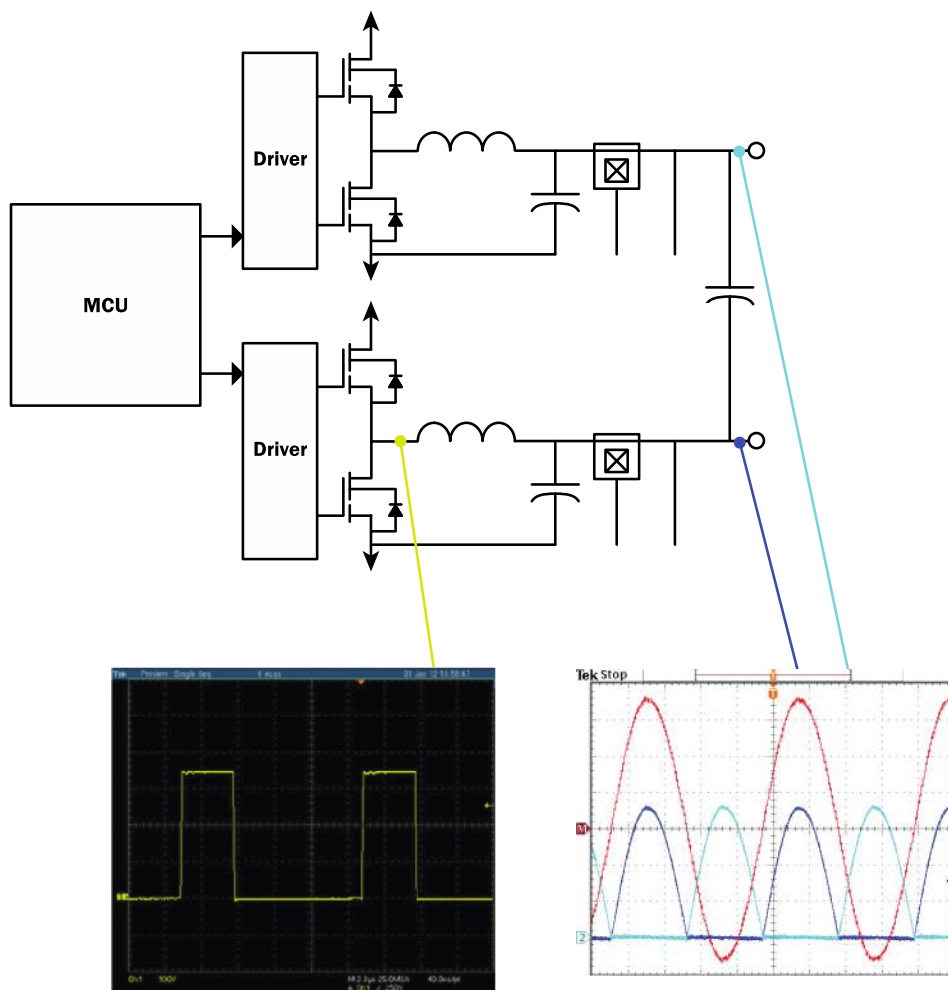

Figure 5. Typical waveforms

TDINV1000P100 User Guide

Typical efficiency results are shown in Figure 6. These data points correspond to efficiency measurements made in still air with 20 minutes' dwell at each power level. Input power from the 750V_{DC} source and output power to a resistive load were measured with a Yokogawa WT1800 power analyzer.

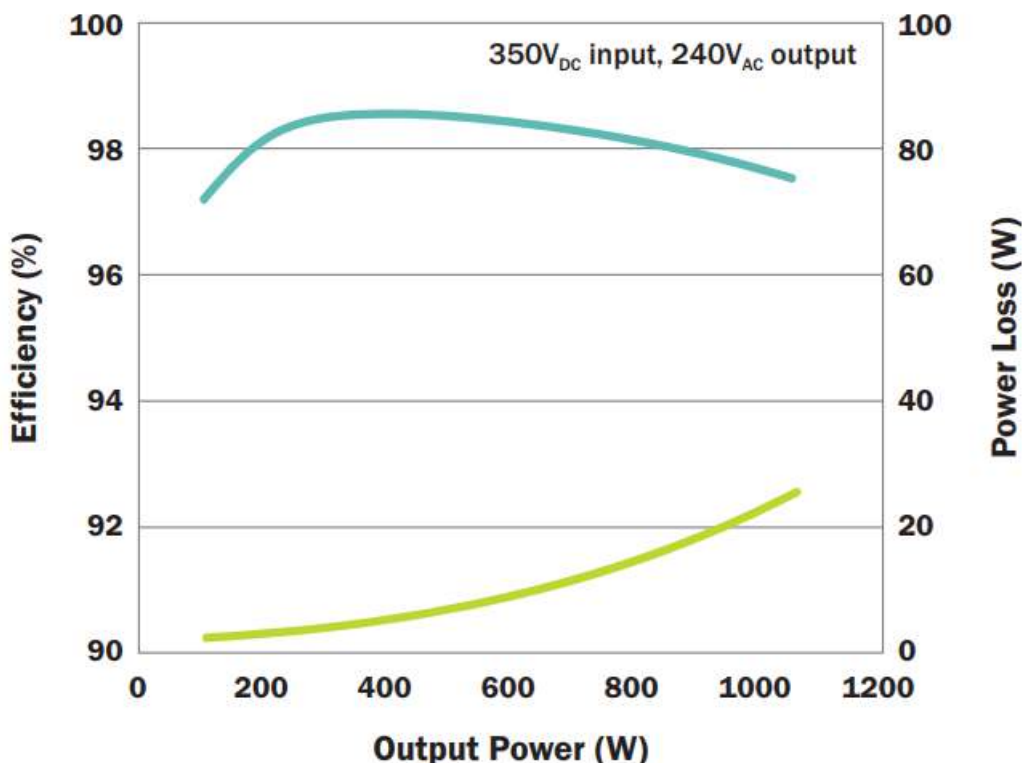

Figure 6. Typical efficiency: 350V_{DC} input, 240V_{AC} output, 100kHz

Design details

See Figures 7 and 8 for a detailed circuit schematic and Figure 9 for the PCB layers (also included in the [design files](#)). The parts list can be found in Table 1.

Table 1. TDINV1000P100 evaluation board bill of materials (BOM)

TDINV1000P100_OV2					
Qty	Value	Device	Parts	Manf	Manf P/N
2		529802B02500G_PINS	HS1, HS2	Aavid Thermalloy	529802B02500G
4		KEYSTONE_7691	J2, J3, J4, J5	Keystone	7691
1		LEDCHIP-LED0805	LED1	Rohm	SML-211UTT86

TDINV1000P100 User Guide

2	295uH INDUCTOR	295uH INDUCTOR	L1, L2	CWS	CWS-1SN-12471
1		PJ-002AH	J1	CUI Inc	PJ-002AH
2		TEKTRONIX-PCB	U_VDS, V_VDS	Tektronix	131-4353-00
6		TESTPOINT- KEYSTONE5015	TP3, TP4, TP5, TP6, TP9, TP10	Keystone	5015
11	.1u	C-USC0603	C1, C13, C14, C15, C16, C19, C20, C21, C22, C25, C27	AVX	06033C104JAT2A
4	.1u	C-USC0805	C8, C9, C10, C11	AVX	08053C104KAT2A
1	.1u	C-USC2225K	C5	Kemet	C2225C104KFRACTU
2	0	R-US_R0603	R52, R53	Yageo	RC0603JR-070RL
1	0	R-US_R1206	R3	Panasonic	ERJ-8GEY0R00V
8	1.6M	R-US_R1206	R33, R34, R35, R36, R37, R38, R39, R40	Panasonic	ERJ-8ENF1604V
1	1k	R-US_R0805	R1	Panasonic	ERJ-6GEYJ102V
2	1n	C-USC0805	C7, C12	Yageo	CC0805KRX7R9BB102
2	1n dni	C-USC0603	C26, C28	DNI	DNI
2	5.23k	R-US_R0603	R18, R23	Panasonic	ERJ-3EKF5231V
2	5.76k	R-US_R0603	R4, R5	Yageo	RC0603JR-070RL
1	2uF	B32674D6225K000	C42	EPCOS	B32674D6225K000
3	9.09k	R-US_R1206	R22, R27, R32	Panasonic	ERJ-8ENF9091V
4	10	R-US_R0805	R6, R7, R8, R9	Panasonic	ERJ-6GEYJ100V
4	10	R-US_R1206	R45, R46, R48, R49	Stackpole	RNCP1206FTD10R0
2	10.2k	R-US_R0603	R19, R24	Panasonic	ERJ-3EKF1022V
4	10k	R-US_R0603	R11, R13, R15, R17	Panasonic	ERJ-3GEYJ103V
5	10k	R-US_R1206	R41, R42, R43, R44, R51	Yageo	RC1206FR-0710KL
4	10n / 630V	C-EUC1206	C34, C35, C38, C39		GRM31BR72J103KW0 1L

TDINV1000P100 User Guide

4	10u	C-EUC0805	C17, C18, C23, C24	Kemet	C0805C106M4PACTU
1	10u	C-USC1206	C4	AVX	CL31A106KAHNNNE
4	15 DNI	R-US_R1206	RSN1, RSN2, RSN3, RSN4	DNI	DNI
4	20	R-US_R0603	R10, R12, R14, R16	Vishay	CRCW060320R0FKEA
4	22pF DNI	C-EUC1206	CSN1, CSN2, CSN3, CSN4	DNI	DNI
1	22u	C-USC1206	C2	Samsung Electronics	CL31X226KAHN3NE
2	100nF	C-EUC1206	C31, C32	Samsung Electro- Mechanics	CL31F104MBCNNNC
1	100pF (10v)	C-USC0603	C33	Würth Electronics	885012006008
1	100u	PANASONICFPV	C3	Panasonic	EEE-FPE101XAP
4	120	FB0603	FB1, FB2, FB3, FB4	Taiyo Yuden	FBMH1608HL121-T
2	220pF	C-EUC1206	C29, C30	Würth Electronics	885012008014
1	348	R-US_R0805	R2	Panasonic	ERJ-6ENF3480V
4	560k	R-US_R1206	R20, R21, R25, R26	Yageo	RC1206FR-07560KL
4	680k	R-US_R1206	R28, R29, R30, R31	Panasonic	ERJ-P08J684V
2	ACS723	ACS723	U5, U6	Allegro Microsystem s	ACS723LLCTR-20AB-T
1	DIM100_TICONTROLCA RD	DIM100_TICONTROLCA RD	CN1	TE Connectivity	5390213-1
2	DNI	C-USC2225K	C43, C44	DNI	DNI
2	DNI	R-US_R0603	R54, R55	DNI	DNI
1	15uF	15uF	C6	TDK	MKP1848622454P4
1	OPA2350UA/2K5	OP_JC	U7	Texas Instruments	OPA2350UA/2K5
1	PTH08080WAH	PTH08080WAH	U2	TI	PTH08080WAH
2	SI8273	SI8273	U3, U4	Silicon Labs	SI8273AB-IS1
4	TPH3206PSB	TPH_TO220VERT_TRI	Q1, Q2, Q3, Q4	TRANSPHOR M	TPH3206PSB

TDINV1000P100 User Guide

1	TPS79533	TPS79533	U1	TI	TPS79533DCQR
2	ES1J	DIODE-DO-214AC	D1, D2	Fairchild	ES1J
2	Q1, Q3 insulator			Bergquist	SP2000-0.015-00-54
2	Q2, Q4 insulator			Aavid Thermalloy	53-77-9G
"screw on TPH3206PS B to heatsink	2		Screw on TP90H180 PS to heatsink	Keystone	9902
Used to mount TPH3206PS B to heatsink	2		Nut to mount TP90H180 PS to heatsink	Keystone	9600
used in between screw/nut and TPH3206PS B	4		Nylon washer shoulder in between screw/nut and TP90H180 PS	Keystone	3049
To place under PCB (5 locations: 4 each corner, 1 in the middle	5		Bumper to be placed under PCB (5 locations: 4 each corner, 1 in the middle)	3M	SJ-5003(BLACK)
1	9Vdc aux supply	9Vdc aux supply	9Vdc aux supply	XP Power	VER05US090-JA
1	CONTROL CARD PICCOLO ISO F28035	CONTROL CARD PICCOLO ISO F28035	CONTROL CARD PICCOLO ISO F28035	Texas Instruments	TMDSCNCD28035ISO

TDINV1000P100 User Guide

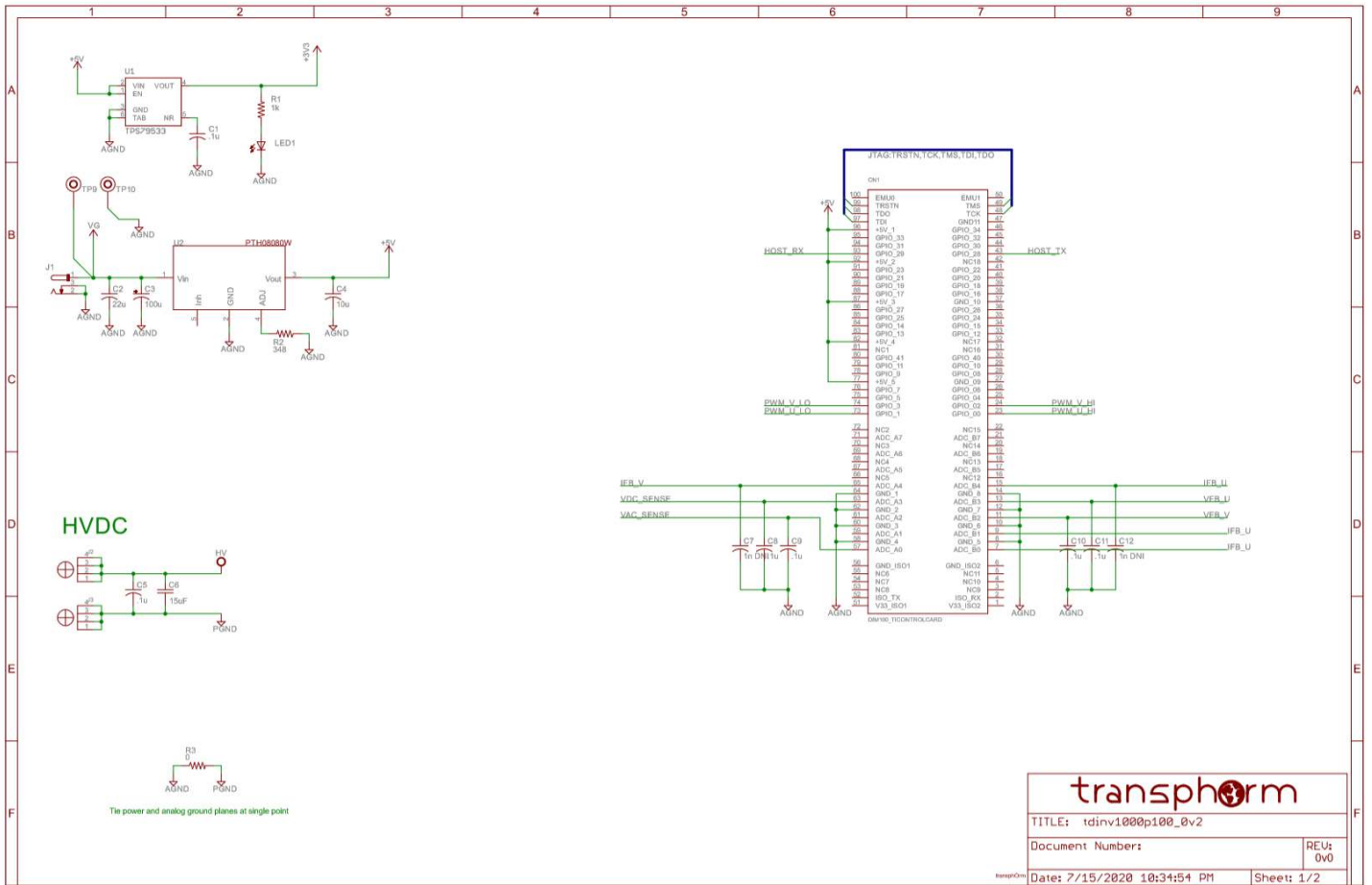

TDINV1000P100 User Guide

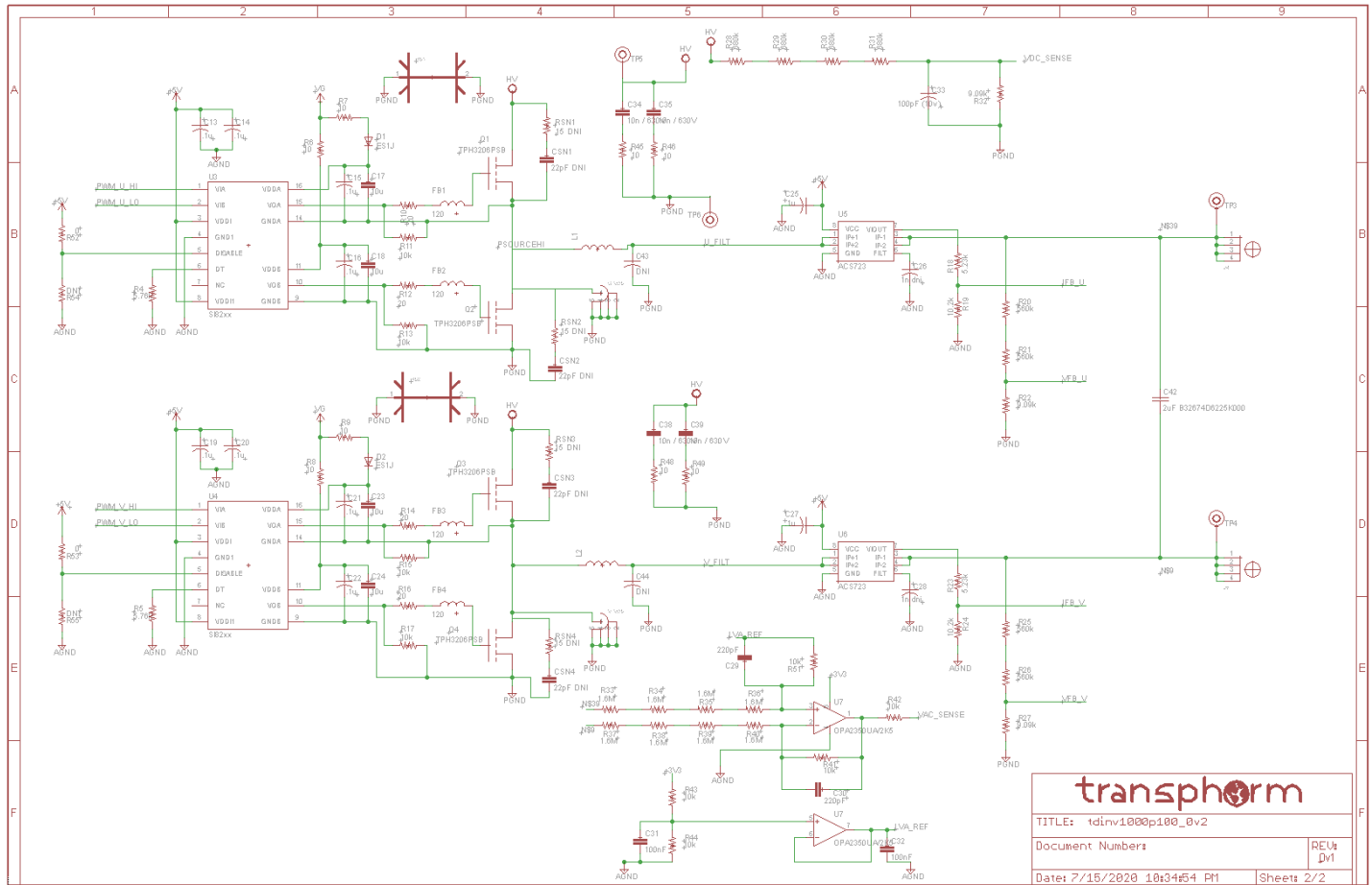
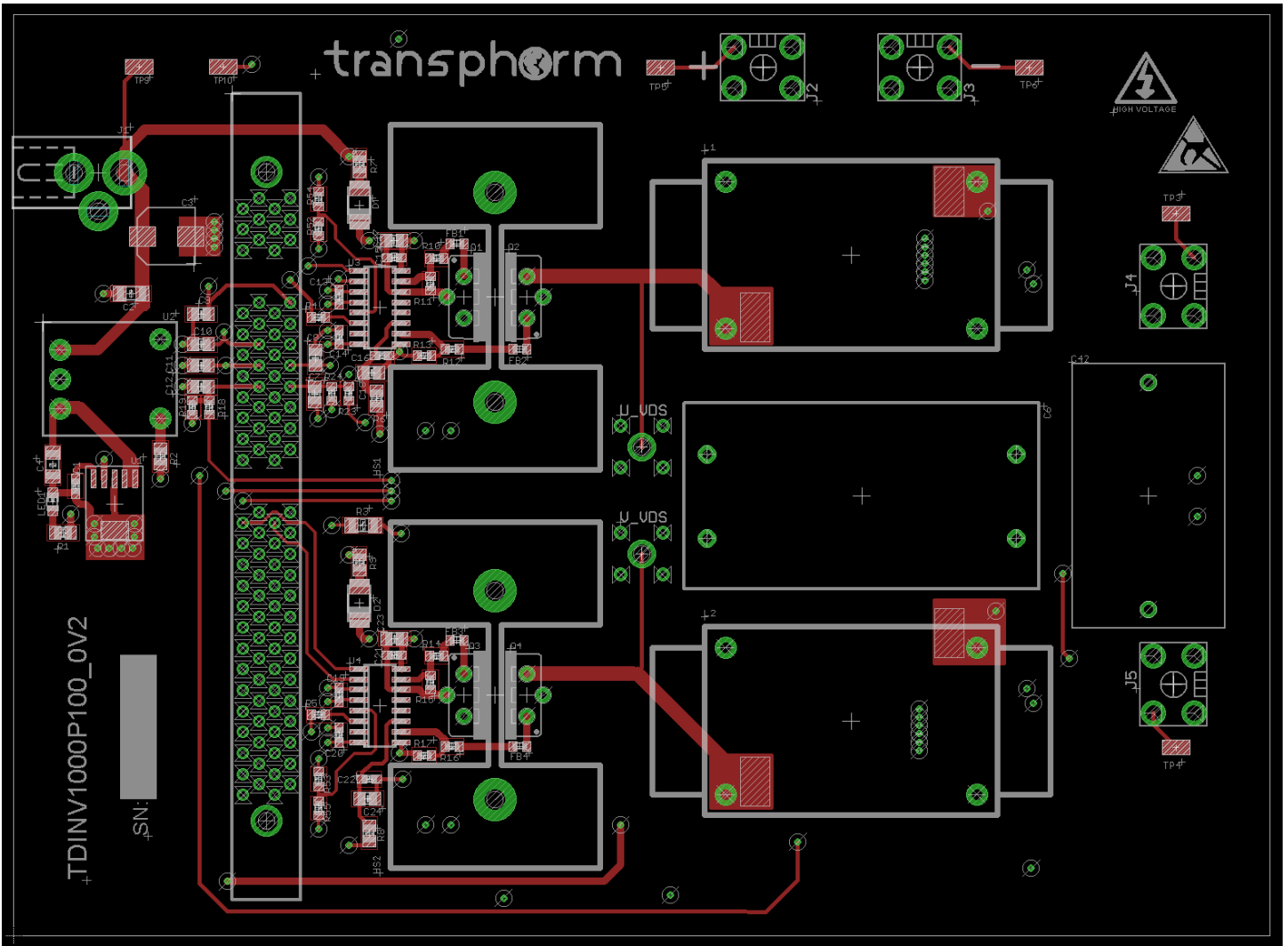

Figure 8. Detailed circuit schematic (2 of 2)

TDINV1000P100 User Guide



(a) PCB top layer

TDINV1000P100 User Guide

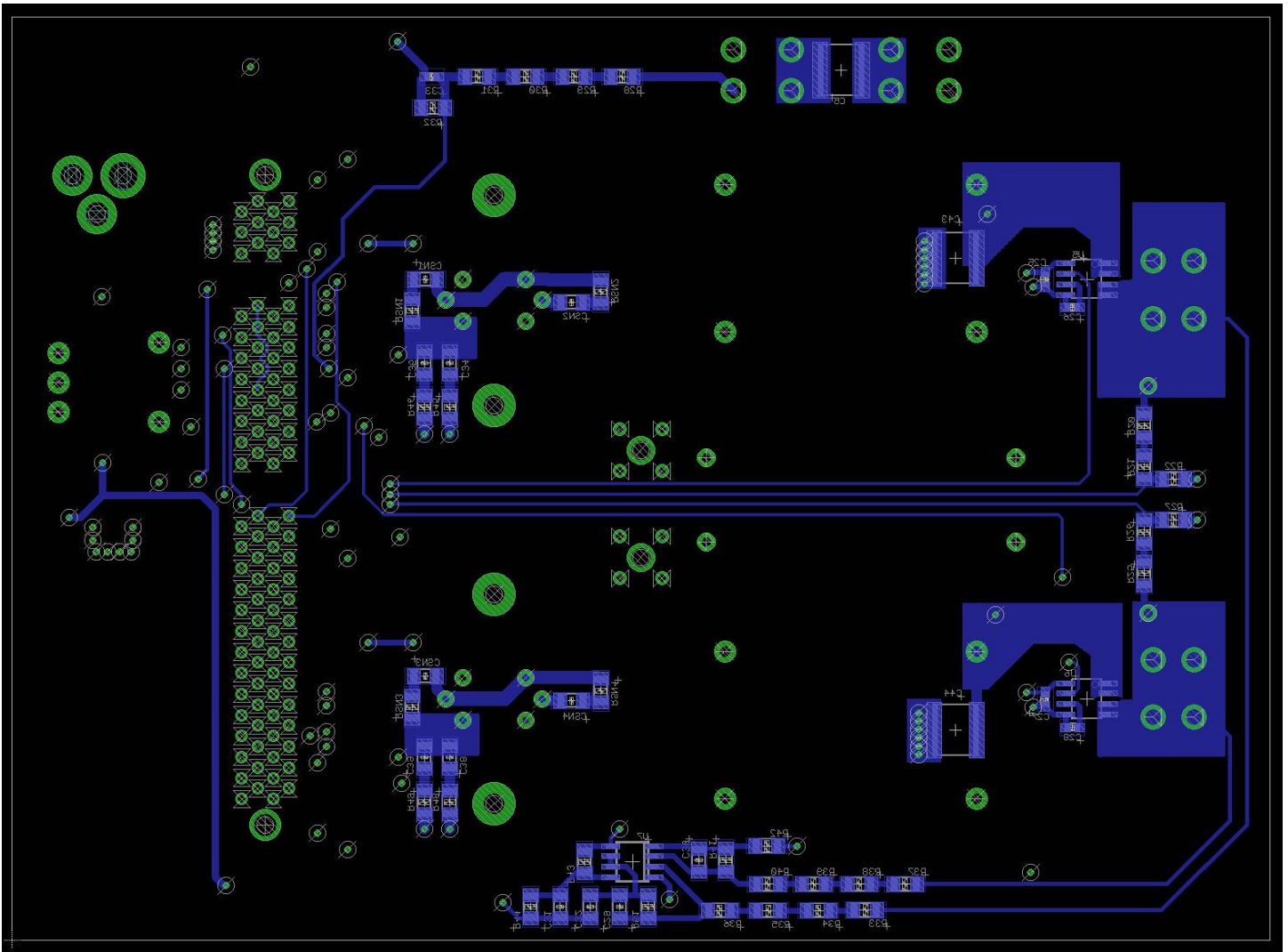

(b) PCB bottom layer

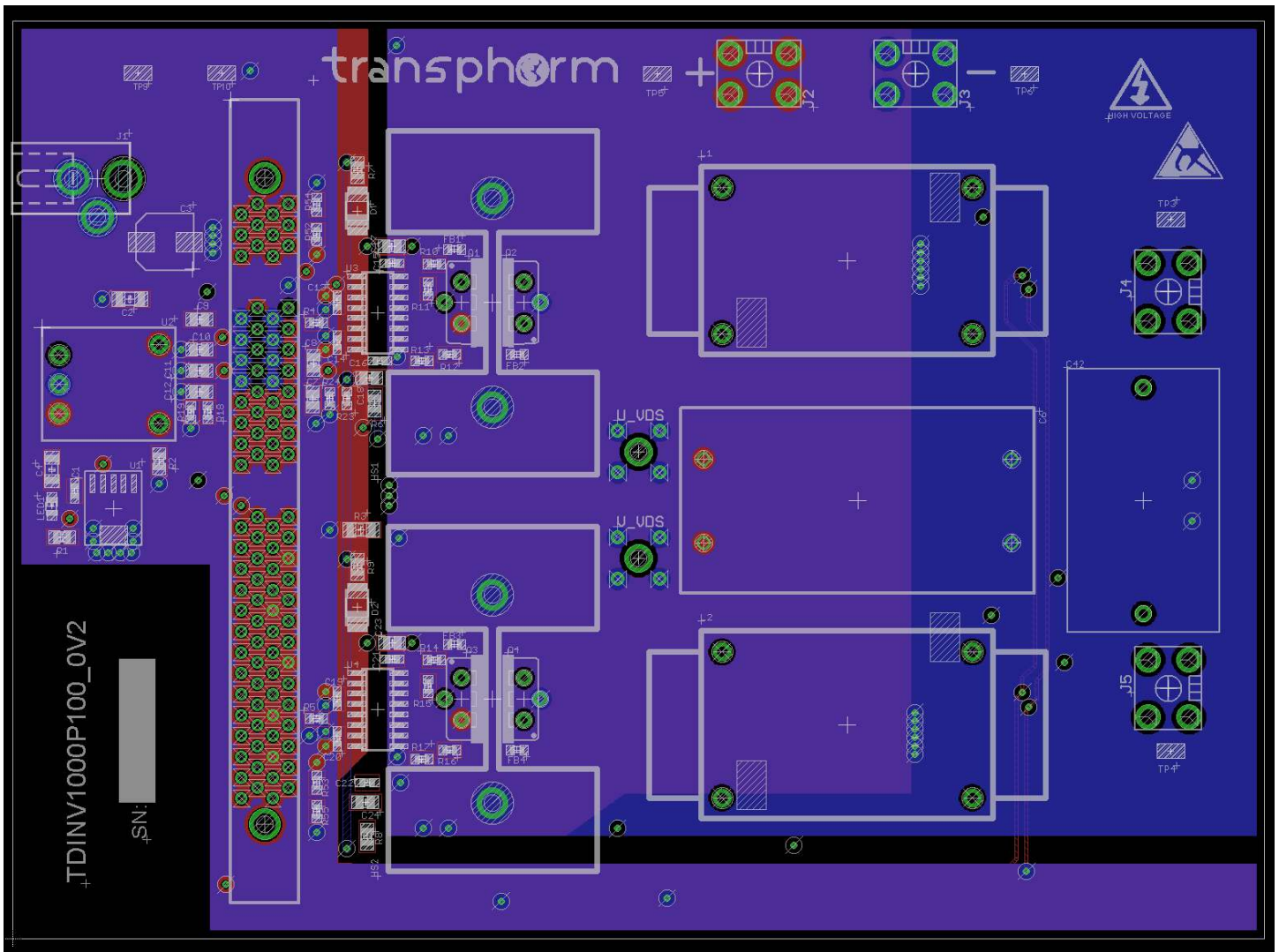

(c) PCB inner layer 2 (ground planes) and inner layer 3 (power plane)

Figure 9. PCB layers

Probing

There are two available Tektronix test points on the PCB used to monitor the low-side switching (node) capability of each half-bridge circuit during operation.

To minimize inductance during measurement, the tip and the ground of the probe should be directly attached to the sensing points to minimize the sensing loop. For safe, reliable, and accurate measurement, a scope probe tip may be directly soldered to the low-side FET drain and a short ground wire soldered to the low-side FET source. See Figure 10 for an alternative that does not require soldering the probe tip.

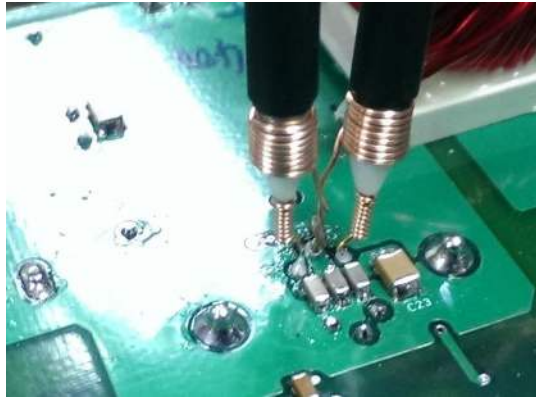

Figure 10. Low-inductance probing of fast, high-voltage signals

Protection features

Current limit

The TDINV1000P100 evaluation board supports user-defined current limit thresholds in both the positive- and negative-going directions. The current limits are peak and in amps.

```
44 // OCP setting:  
45 #define OCP_LV_UP 1800
```