

THIS DRAWING IS UNPUBLISHED. RELEASED FOR PUBLICATION 20
 © COPYRIGHT 20 BY - ALL RIGHTS RESERVED.

REVISIONS					
P	LTR	DESCRIPTION	DATE	DWN	APVD
	C	ECR-15-008603	23JUN2015	KG	DW

I. PACKAGED LOOSE PIECE.

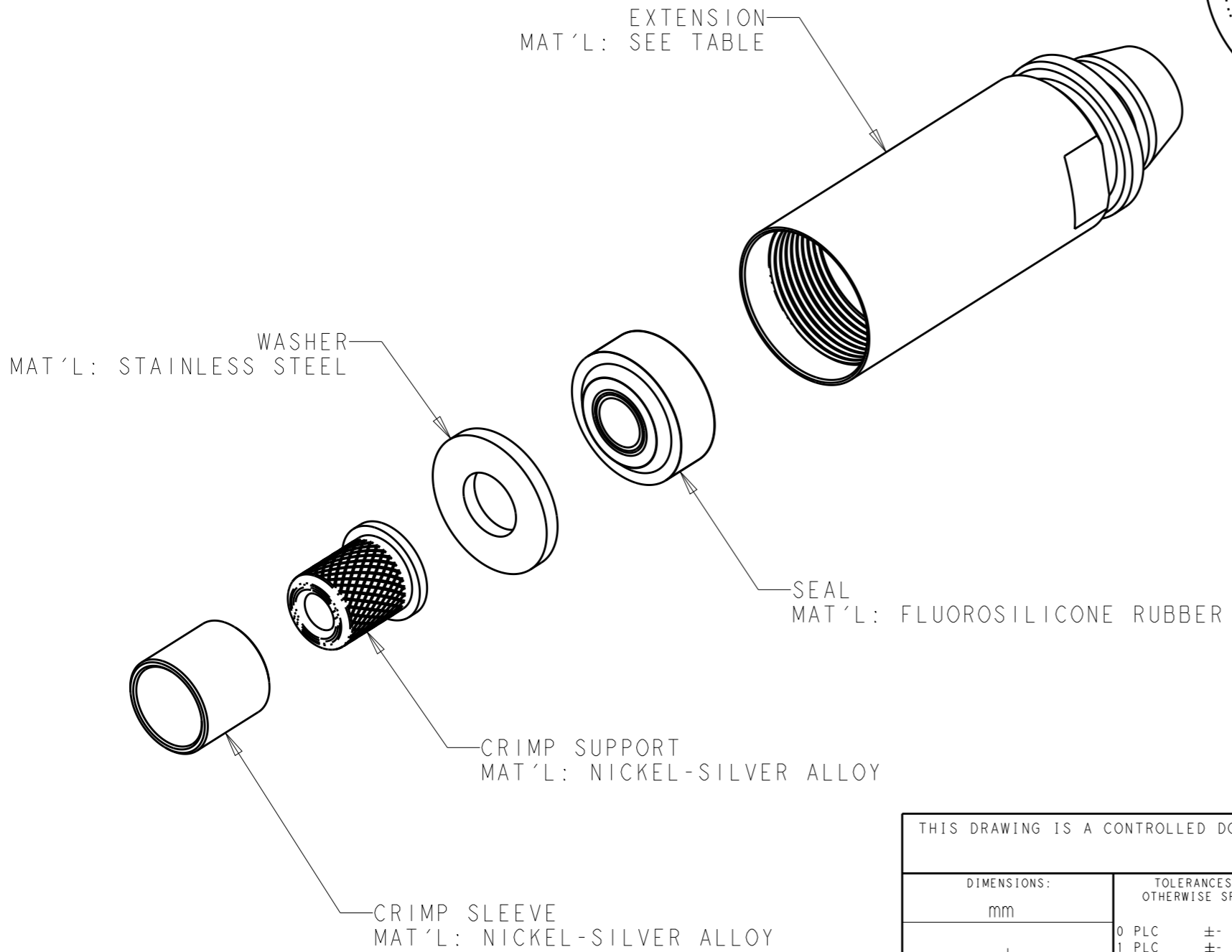

BOOT MATERIAL	EXTENSION MATERIAL	MAXIMUM CABLE SIZE	PART NUMBER
FLUROSILICONE RUBBER	NICKEL ALUMINUM BRONZE	6.7mm	1-1828700-6
		6.2mm	1-1828700-5
		5.6mm	1-1828700-4
		5.1mm	1-1828700-3
EPDM RUBBER	ALUMINUM ALLOY	6.7mm	1-1828700-2
		6.2mm	1-1828700-1
		5.6mm	1-1828700-0
		5.1mm	1828700-9
	NICKEL ALUMINUM BRONZE	6.7mm	1828700-8
		6.2mm	1828700-7
		5.6mm	1828700-6
		5.1mm	1828700-5
	ALUMINUM ALLOY	6.7mm	1828700-4
		6.2mm	1828700-3
		5.6mm	1828700-2
		5.1mm	1828700-1

THIS DRAWING IS A CONTROLLED DOCUMENT.		DWN K. GLATFELTER 17 JUN 2005	TE Connectivity	
DIMENSIONS: mm		CHK D. WERTMAN 24 JUN 2005		
TOLERANCES UNLESS OTHERWISE SPECIFIED:		APVD D. WERTMAN 24 JUN 2005	NAME CABLE ADAPTER KIT, PLUG PRO BEAM MINI	
0 PLC ±- 1 PLC ±- 2 PLC ±- 3 PLC ±- 4 PLC ±- ANGLES ±-		PRODUCT SPEC -	-	
MATERIAL AS LISTED		APPLICATION SPEC -	SIZE A3	CAGE CODE 00779
FINISH HARD ANODIZE (AI ONLY)		WEIGHT -	DRAWING NO C-1828700	RESTRICTED TO -
		Customer Drawing	SCALE 2:1	SHEET 1 OF 1
				REV C